



G5

The NL5000 G5

Walk-Around Guide



www.newleader.com



Building the best since 1939. New Leader Manufacturing is family owned and operated. Our business is built on honesty and integrity. We have a passion for what we do, and we firmly believe that we can make a better tomorrow by building the best today.



The leading brand of dry spinner spreader crop nutrient applicators, New Leader equipment is used to spread fertilizer, lime, and micronutrients. We partner with leading manufacturers such as AGCO, CNH, GVM, John Deere, RBR, and more.

TABLE OF CONTENTS

ABOUT US	02
INTRO TO WALK AROUNDS	03
SPECIFICATIONS	04
NL5000 G5 OVERVIEW	05
COMPONENT VIEWS	06
CHAIN OILER & LUBRICATION	10
HYDRAULIC RESERVOIR AND COOLER	11
HYDRAULIC MANIFOLDS	12
PWM VALVES & SPINNER CONTROL	13
CHAIN TENSIONER	14
G5 SWATH WIDTH CONTROL	15
NL5000 ELECTRONICS	16
NEW LEADER USER INTERFACE	17
MULTAPPLIER & MULTIBIN	18
VALUE STATEMENTS	19

Walk-Arounds

Key Points

With so many new and updated features, the NL5000 G5 capabilities should be properly shown to highlight the customer value. The value of the NL5000 G5 revolves around 3 key items:

- Precision Application
- Ease of Use
- Ease of Maintenance



Specifications

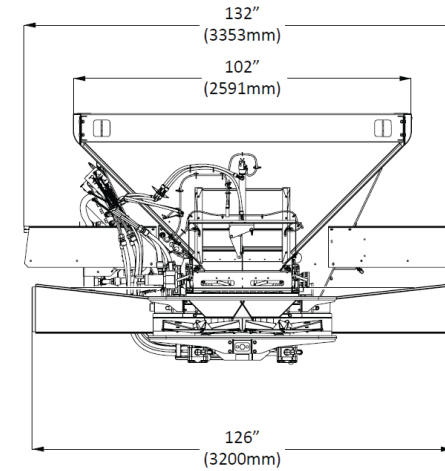
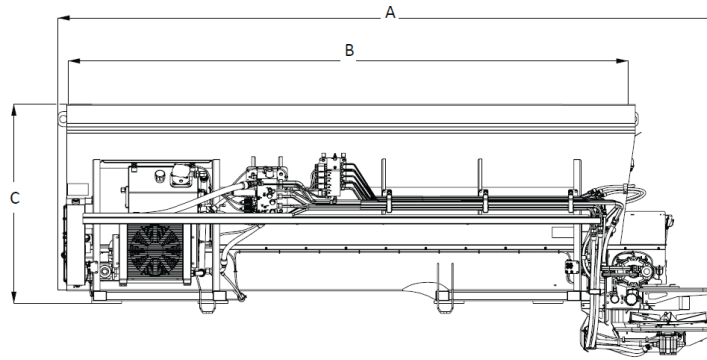

NL5000 G5	
Length	in (cm)
13' (3.96m)	188 (478)
14' (4.27m)	200 (508)
Struck Capacity	Cu Ft (Cu M)
13' (3.96m)	276 (7.82)
14' (4.27m)	298 (8.44)
Estimated Weight	lbs (kg)
13' (3.96m)	4900 (2223)
14' (4.27m)	5100 (2313)

MultiBin - Sideboard Included	
Struck Capacity	Cu Ft (Cu M)
13' NL5000 w/ MultiBin - Bin 1	166 (4.70)
14' NL5000 w/ MultiBin - Bin 1	195 (5.52)
MultiBin - Bin 2	139 (3.94)
MultiBin - Bin 3	23 (.65)
MultiBin - Bin 4	21 (.59)

MultiApplier	5ft MultiApplier	7ft MultiApplier
Est. Ship Weight	1200 (544kg)	1400 (635kg)
	Capacities with 5 ft. MultiApplier Cu ft (Cu M)	Capacities with 7 ft. MultiApplier Cu ft (Cu M)
Insert Capacity	115 (3.25)	161 (4.60)
13' (3.96m) Bin 1 Total Struck Capacity	224 (6.34)	166 (4.70)
13' (3.96m) Bin Total Struck Capacity	339 (9.59)	327 (9.26)
14' (4.27m) Bin 1 Total Struck Capacity	253 (7.16)	195 (5.52)
14' (4.27m) Bin 1 Total Struck Capacity	368 (10.42)	356 (10.08)

MultiBin - Sideboard Included	
13' Unit - Bin 1 Length w/ MultiBin (B)	72 in (183cm)
14' Unit - Bin Length w/ MultiBin (B)	84 in (213cm)
Est. Ship Weight	1800 (816kg)

NL5000 G5 Overview

No Time for Downtime

The NL5000 G5 is a hopper-type spreader intended for spreading free flowing granular agricultural materials, such as dry fertilizers, agricultural limestone, gypsum, seeds, and cover crops. It is intended for agricultural vehicle mounting.

The unit is powered hydraulically and provides independent variable speed control for the spinner and full automatic ground speed control for the conveyor.

The conveyor delivers material to the spinners through a hydraulically adjustable metering gate at the rear of the hopper body. Orbital-type hydraulic motors mounted to 6-to-1 ratio spur gear case drive the conveyor. The conveyor is a belt-over-chain type, having parallel strands of pintle-type (#4) chain joined by cross bars every other link.

The spinner assembly has two 24-inch (610 mm) diameter dished discs. Each disc has four formed and heat treated fins that are adjustable to radial angle. The spinner assembly is fully adjustable by means of a hydraulic cylinder.

The optional 304 stainless steel hopper-style spreader MultiApplier or MultiBin may be inserted in the main bin.

- Inserting the MultiApplier allows for two materials to be spread simultaneously. It features a 24-inch (60.96 cm) 409 stainless steel belt-over-chain type conveyor having parallel strands of 409 stainless steel pintle-type (#4) chain joined by cross bars every other link. The direct driven conveyor is also controlled independently enabling the delivery of material at variable rates through the adjustable gate at the rear of the hopper body. It also utilizes a hydraulically adjustable metering gate. The waterfall divider improves material placement on the spinner for a more effective spread pattern.
- Inserting the MultiBin will convert the spreader to a 3- or 4-hopper unit, which can be used independently or together for straight and variable rate applications. The front two hoppers dispense fertilizer products while the single or dual hopper at the rear dispense(s) micronutrients or seeding products. The rear bin(s) are sloped forward to improve chassis weight distribution. Material is delivered from the front bin by conveyor and from the rear bin(s) by passing through a stainless steel metering wheel, material dividers and main spinner assembly. Bin sensors are installed to warn when materials are low in each micronutrient bin.
 - The MultiBin also comes equipped with an upper and lower material divider which improves material placement on the spinner for a more effective spread pattern.
 - An optional micronutrient stainless steel cover which opens and closes with a stainless steel air cylinder is available.
 - Screens installed on micronutrient bins keep large chunks of material out of the bins by breaking the material up as it enters the bins.

Front View

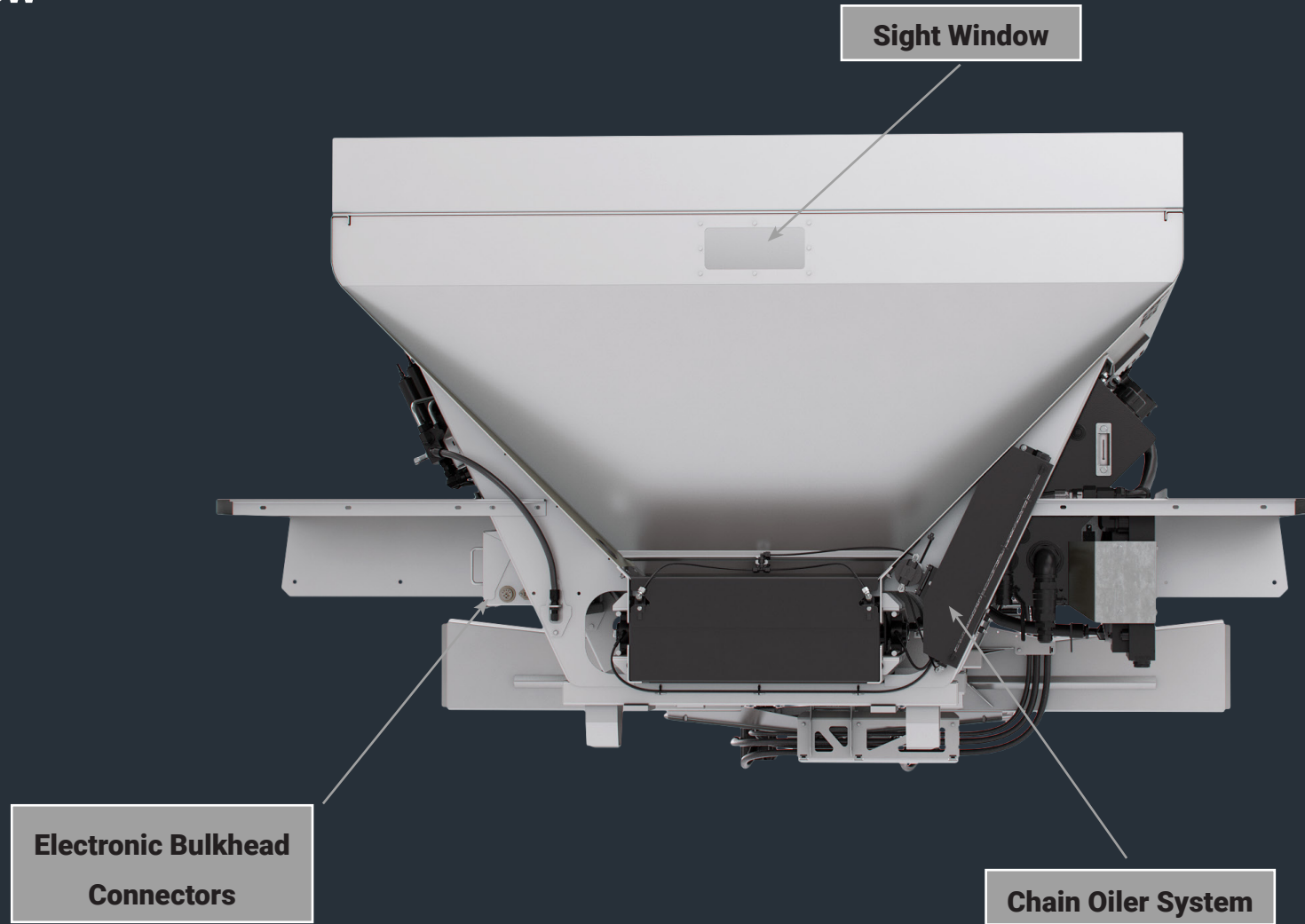

Left-Hand Side View

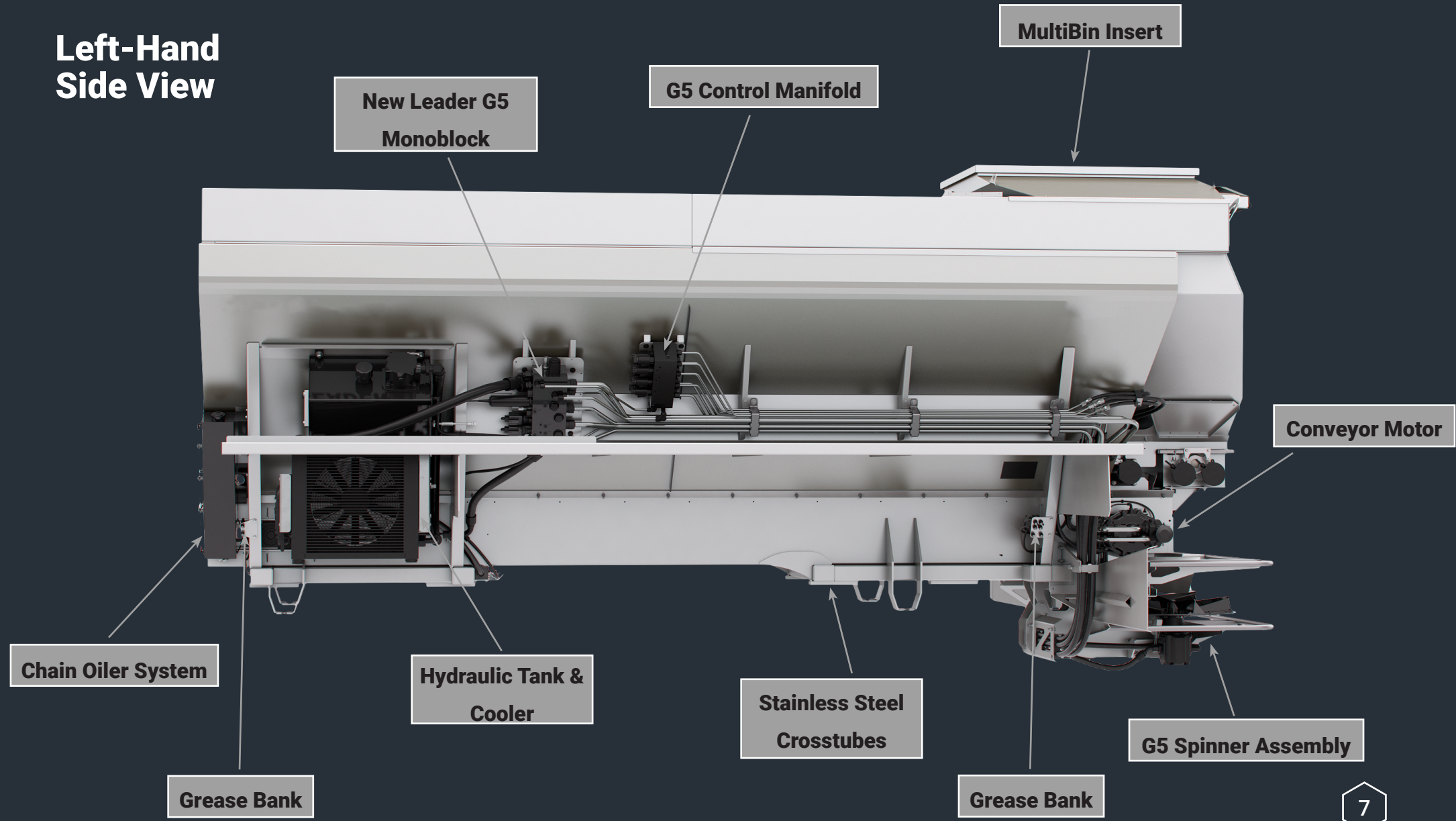

Rear View

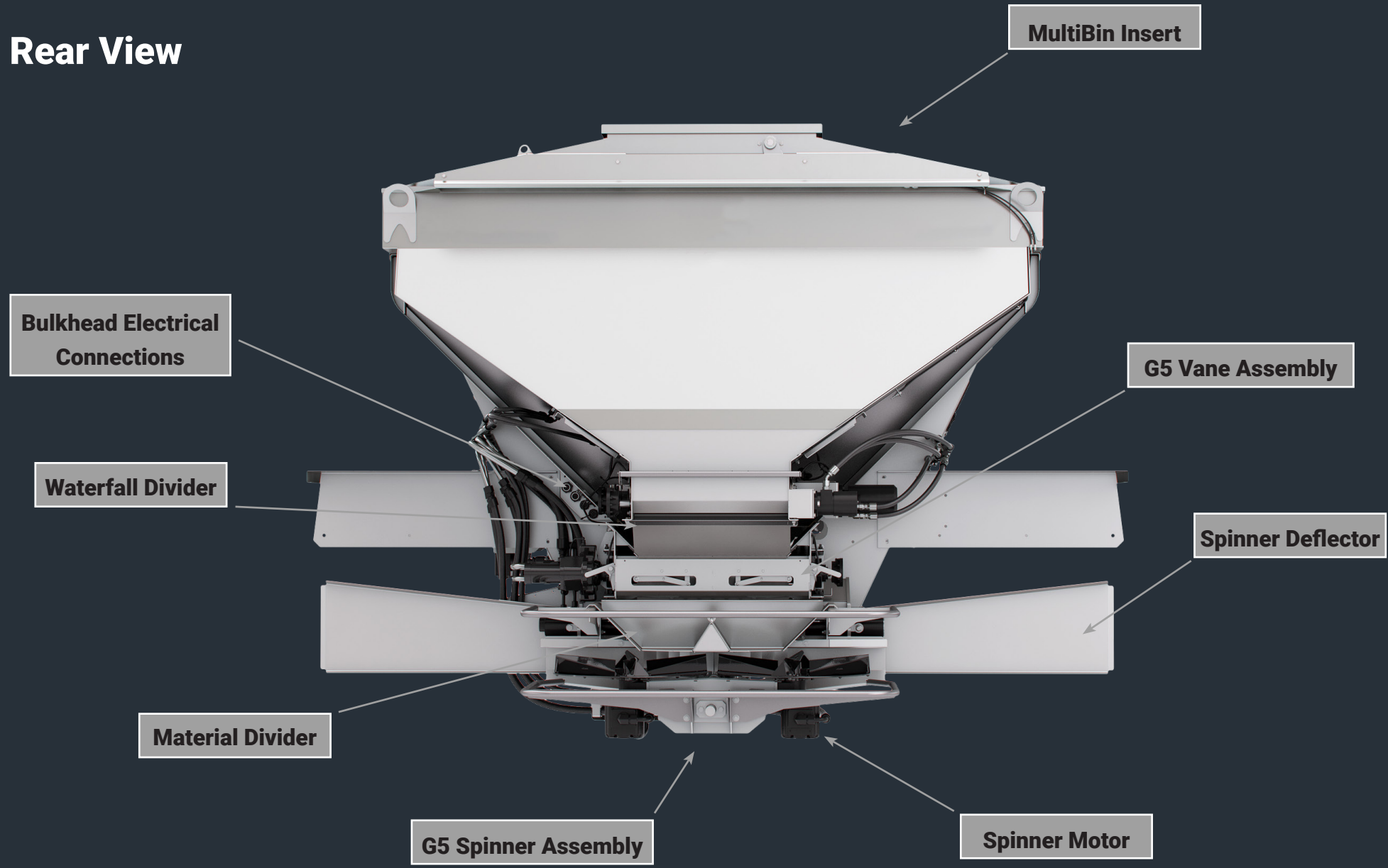

Right-Hand Side View

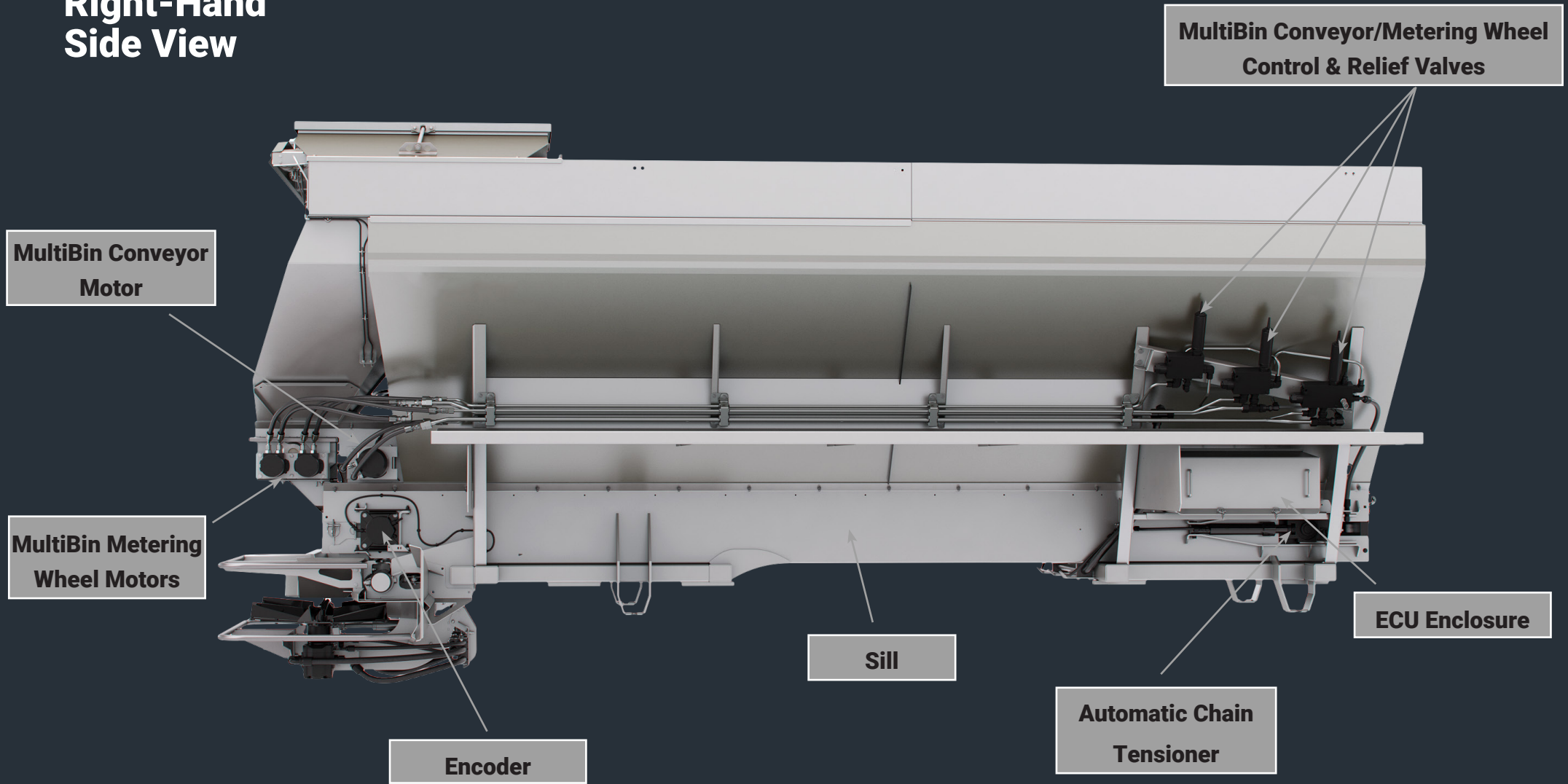

Chain Oiler and Lubrication

Key Points

- In-cab and automated conveyor chain oiler controls and simplifies daily maintenance
- Extends chain life on one of the most expensive consumable components
- Centralized lubrication points for easy and quick maintenance

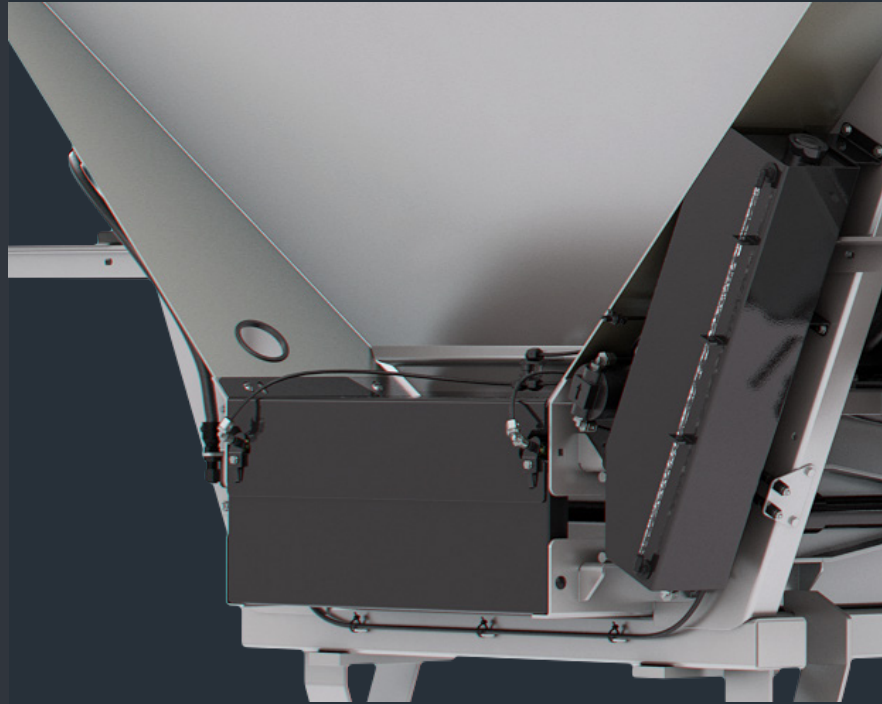

The pressurized chain oiler is for performing lubrication service of the belt-over-chain conveyor. This system is operated through the controller and accessed through the display. By setting oiling reminders, the operator is notified when the set time limit is reached and the chain needs to be lubricated. This reduces wear of the chain and deterioration from rust. Utilize a mixture of 75% diesel fuel and 25% clean oil.

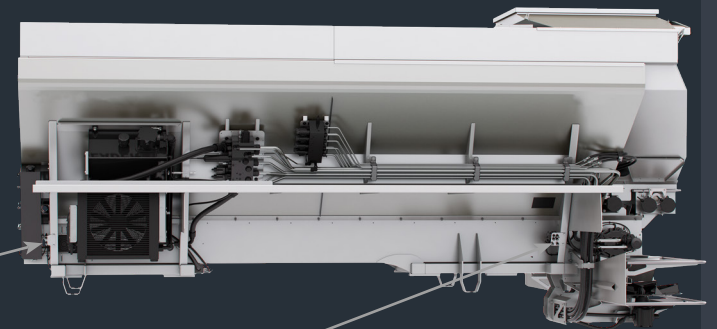

Hydraulic Reservoir & Cooler

Key Points

- Thermostatically-controlled cooler maintains proper working temperatures, improving efficiencies
- Temperature, filter, and low fluid sensors

The hydraulic reservoir and cooler ensures that proper fluid conditions are met. With higher output capabilities, the duty cycles are much greater. With a thermostatically-controlled cooler, the system will maintain a set working temperature, providing a more efficient working system and extended hydraulic component life.

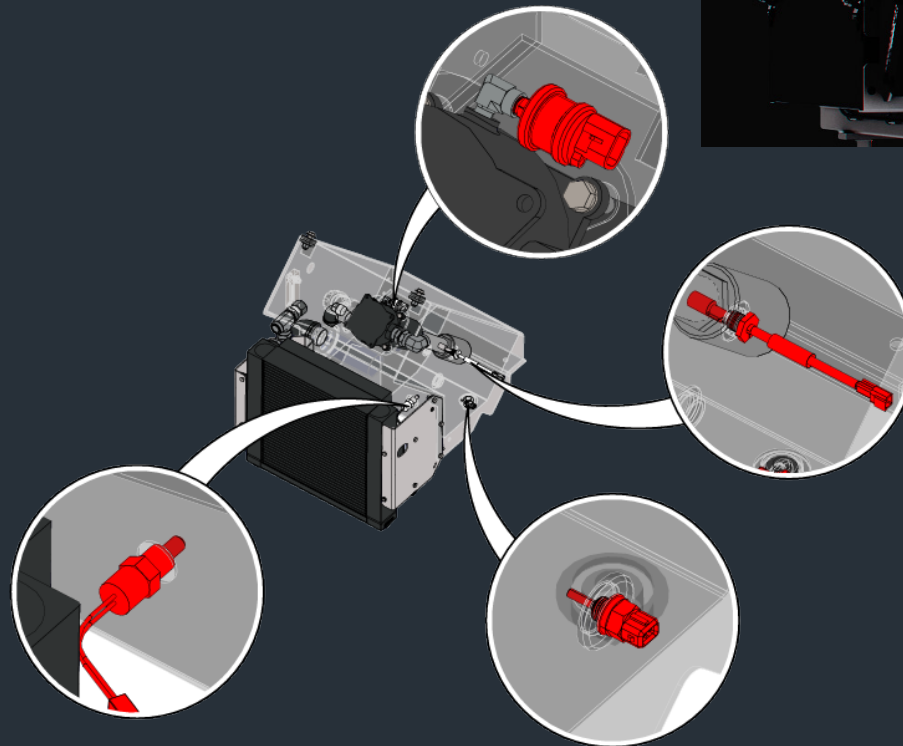
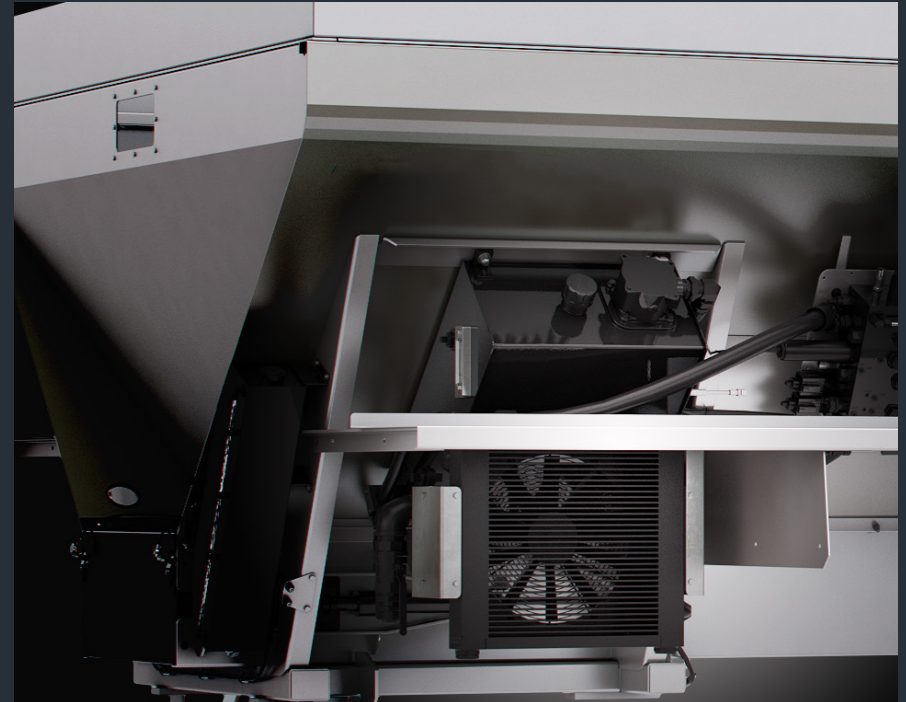

With low fluid, filter, and temperature sensors, monitoring the NL5000 G5 system is simple. All readings are able to be displayed on the monitor, and warnings let the operator know when the system is not performing properly.

Hydraulic Manifolds

Key Points

- Improved efficiencies and control via common manifold
- Hydraulic test ports
- Anti-cavitation valves that smooth spinner shutdown
- Automatic chain tensioner
- Automated spinner control with G5 Control Manifold

All of the main hydraulic functions are tied into two monoblock hydraulic manifolds. The New Leader G5 Monoblock (1) controls the main conveyor, the spinners, and automatic chain tensioning. The G5 Control Manifold (2) controls all of the automated fan frame movements, fore/aft and left/right, and feedgate controls.

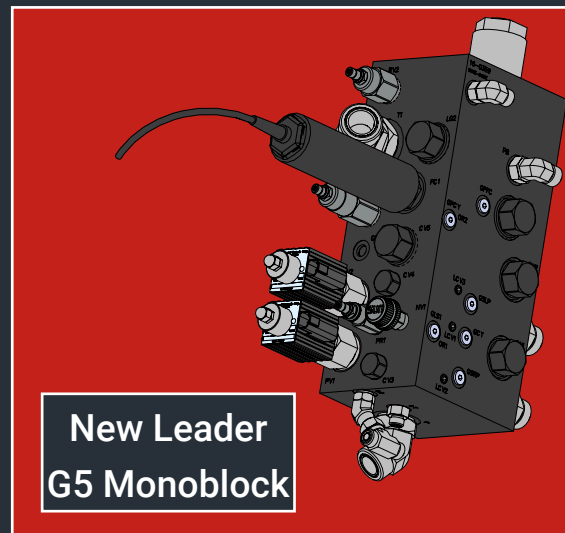
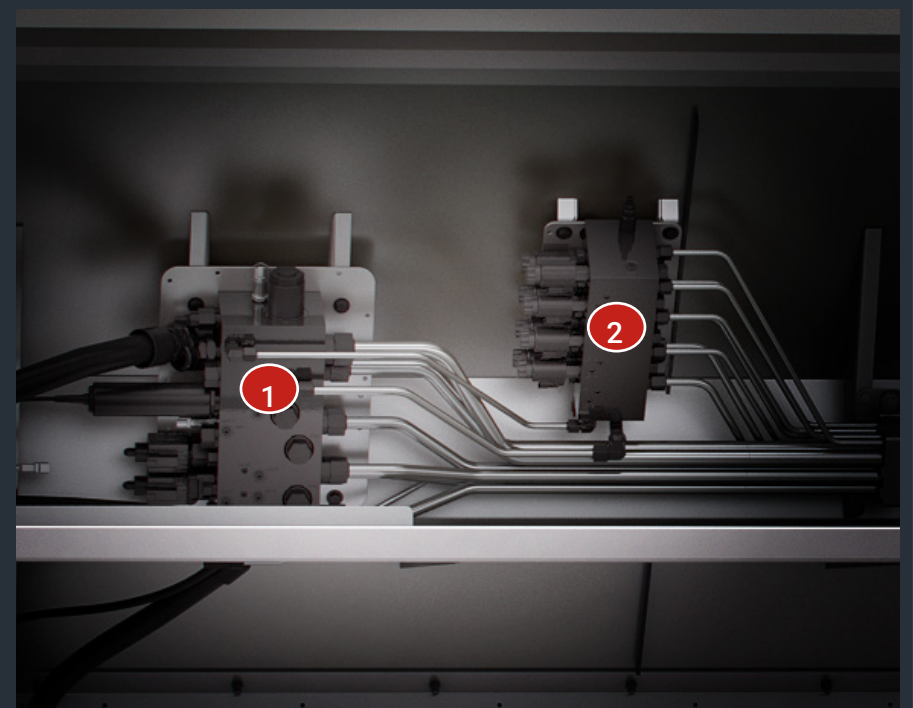

PWM Valves and Spinner Control

Key Points

- Integrated into New Leader Monoblock
- Maintains constant spinner speeds for consistent spread width
- Closed-loop system that adjusts for oil temperature, viscosity, and pressure
- Fast reaction servo valve for high speed applications and quick rate changes

The PWM valves for each spinner are integrated into the New Leader G5 Monoblock. The electronic PWM hydraulic valve is automatically adjusted by the controller to maintain the target spinner speed programmed from the controller. This ensures a consistent and uniform spread pattern at all times.

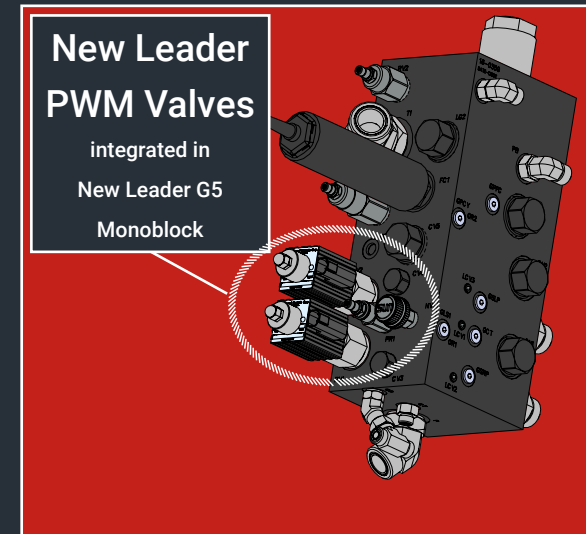
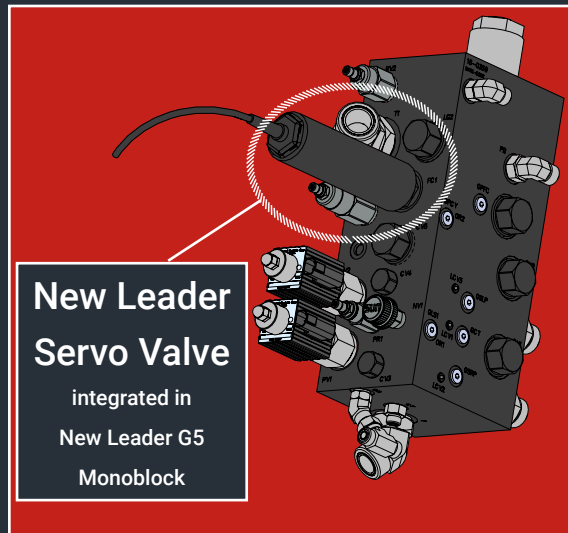

The New Leader Servo Valves for main conveyor control is integrated into the New Leader G5 Monoblock. The servo valve has a fast reaction time to meet high demands when operators are traveling at higher application speed.

Chain Tensioner

Key Points

- Maintains proper conveyor tension at all times during operation
- Reduces maintenance requirements
- 304 stainless steel front idler tensioning brackets



The automatic chain tensioning feature maintains proper conveyor tension and reduces maintenance requirements. When the pump is engaged, both tensioning cylinders are actuated or pressurized. During extended periods of non-use, the cylinders will relax.

A chain tension sight window is located near the rear of the spreader. When the conveyor is running, the top edge of the chain should be visible between the MIN and MAX lines in the window.

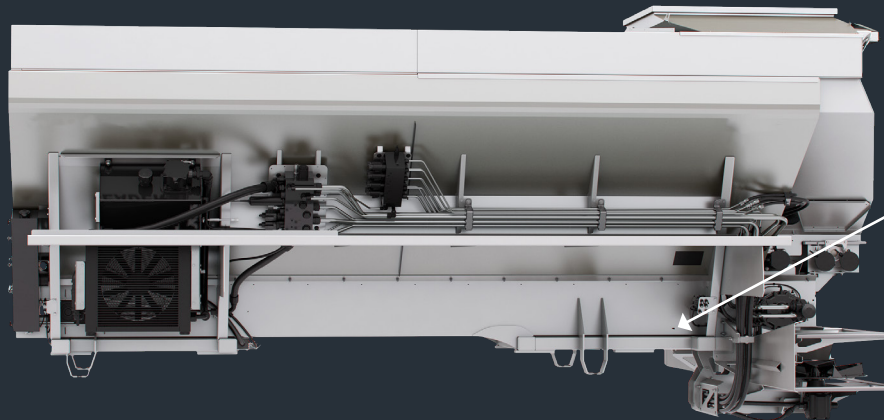

Chain Tension Sight Window

G5 Swath Width Control

Key Points

- 16-section swath width control
- Fore/aft and left/right automated spinner assembly control
- 1/2 width spreading
- Last Pass Control
- Boundary spreading



16-section
Swath Width
Control

The NL5000 G5, with its patented 16-section swath width control technology, lets operators apply nutrients with pinpoint accuracy. By shifting the spinner assembly fore/aft and left/right, and leveraging the conveyor speed adjustments, operators can alter where the product is broadcast in the field. This innovative patented technology reduces overlap, decreases nutrient waste, and ensures nutrients are placed only where they're needed.

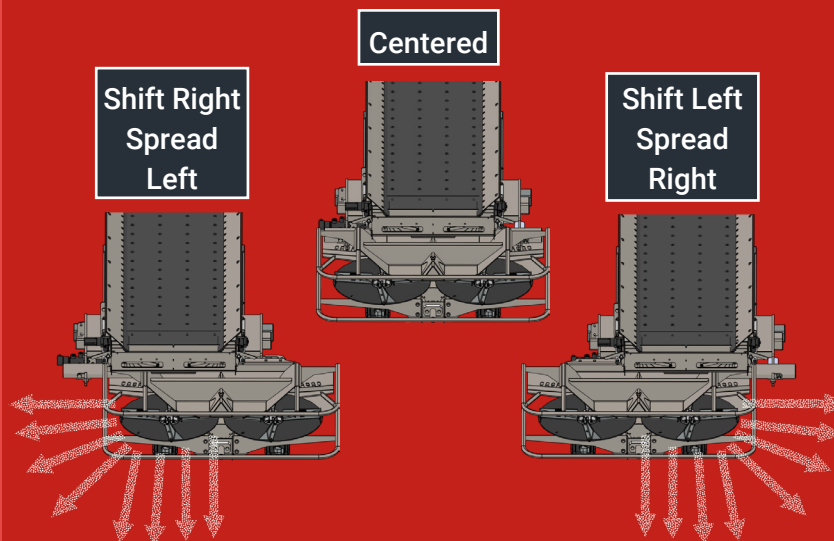

Last Pass Control

NL5000 G5 Electronics

Key Points

- Complete electronic package
- Co-developed with industry leader Ag Leader
- Factory installed and tested
- Diagnostic feedback
- Stainless steel component enclosure
- 2-year warranty for electronics and complete unit

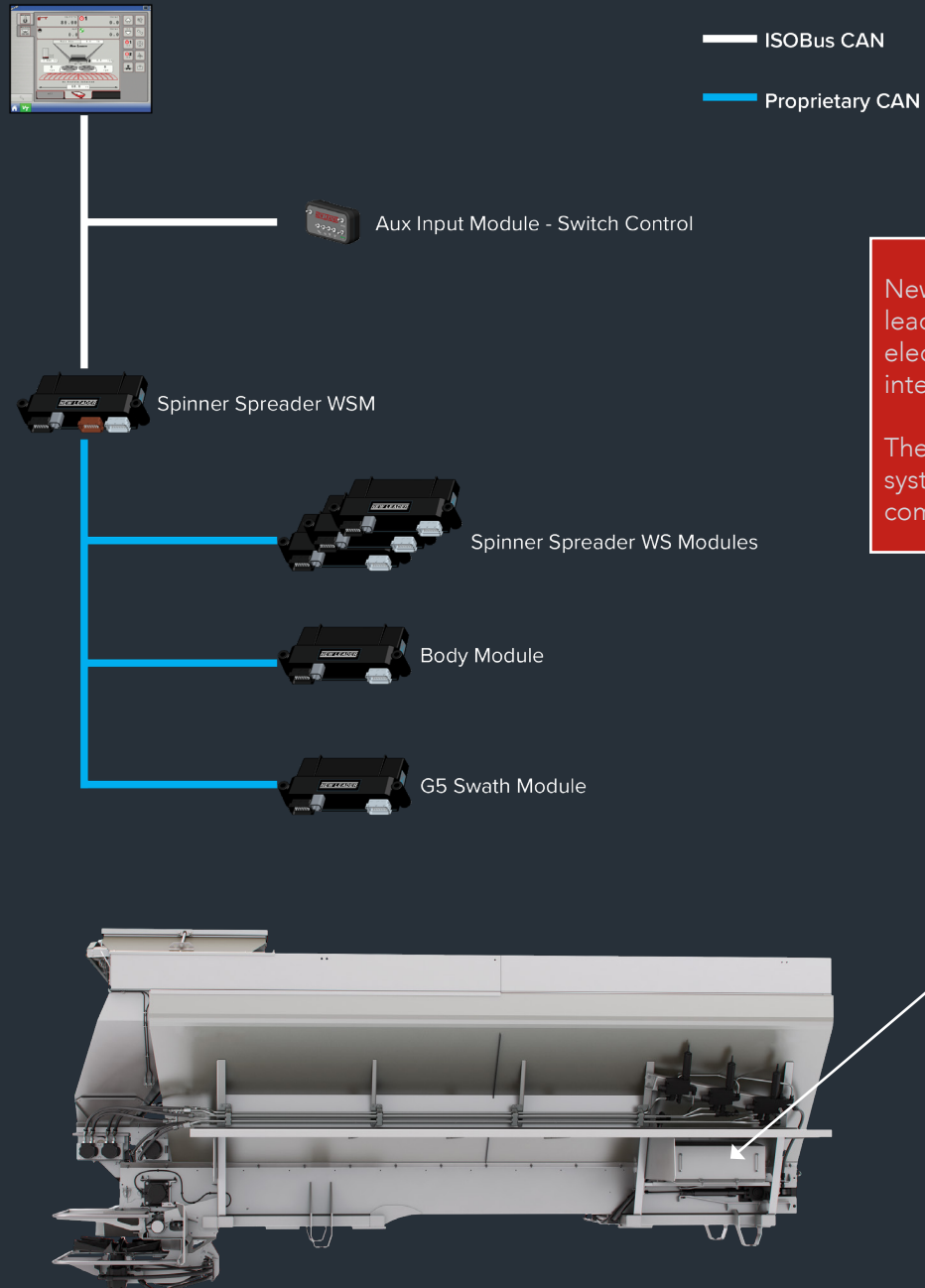

New Leader partnered with industry leader Ag Leader to develop a complete electronic control system and user interface.

The ISO-Ready system utilizes a CAN system with specialized modules to offer complete system control.



New Leader User Interface

Key Points

- Easy-to-use interface
- Up to 25 stored product profiles and patterns
- ISOBUS-ready
- Diagnostic feedback
- Automated service notifications
- Low bin countdown
- Feed gate optimizer

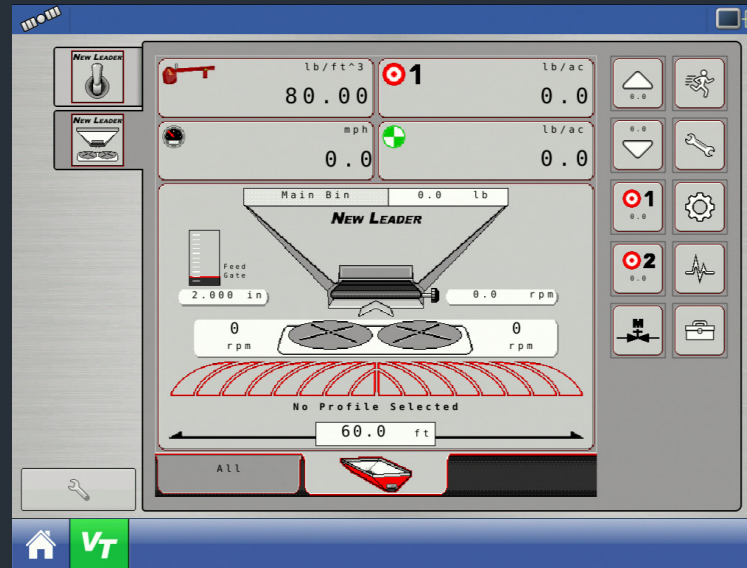

The NL5000 G5 runs completely off New Leader software that is truly plug-and-play with an ISOBUS-ready display. Equipped with hardware to meet ISOBUS (11783) Platform, the New Leader User Interface is all about simplicity; simplicity for our OEM partners, simplicity for our dealers, and simplicity for our customers.

The New Leader User Interface allows us to add fully-tested improvements, and provide the best solution to meet our customers' needs while also providing complete support.

The New Leader User Interface allows customers to use any ISOBUS-ready display in the cab, and allows for complete machine control and monitoring in one simple, easy-to-use package from the factory.

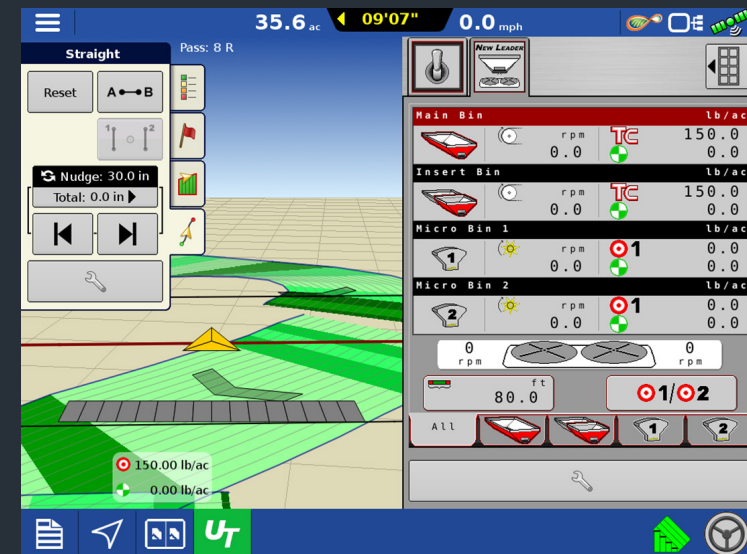

MultApplier & MultiBin

Key Points

- Apply multiple products at once without the need to blend products
- With a MultApplier, apply two products at the same time with independent rates
- With a MultiBin, apply up to four products at once with independent rates

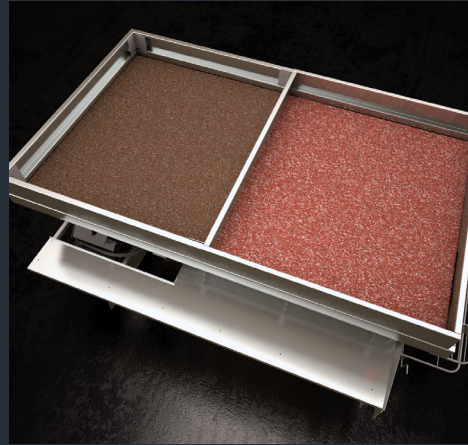

MultApplier

Reduce man hours, field compaction, and fuel consumption by applying two products in a single pass with the MultApplier, available in 5-ft or 7-ft sizes.

Independent conveyors allow two products to be applied at independent or variable rates at the same time.

Bolted-in endgate makes the MultApplier easy to install or remove.

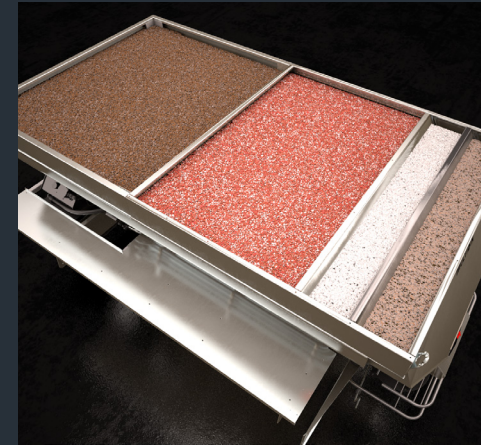

MultiBin

Transform a single-bin spreader into a three or even four bin spreader with the MultiBin insert. This innovative design gives operators the power to broadcast materials independently or simultaneously, and at straight or variable rates.

The front two hoppers dispense fertilizer products, while the rear hopper dispenses micro-nutrients or seeding products. This rear hopper can also be split to create a fourth hopper.

The MultiBin can be easily removed from the main spreader for single-bin fertilizer or lime spreading.



The conveyor and metering wheels are controlled through the insert conveyor control valves located on the right-hand side of the machine.

Value Statements

Precision Application

- 16-section swath width control
- 1/2 width spreading
- Last Pass Control
- Boundary spreading
- Automatic feedgate and fan frame control
- Precise independent spinner control and monitoring
- Up to 4 products

Ease of Use

- New Leader user interface
- System sensors
- Feed gate optimizer
- Diagnostic feedback
- Complete controller package installed
- Automatic feedgate and fan frame control

Ease of Maintenance

- Centralized lubrication
- Manufactured to reduce adjustments
- Automatic chain tensioner
- 304 stainless steel cross tubes, mounts, and take-up brackets
- Automatic chain oiling
- System sensors



“To radically improve the way dry nutrients are applied.”



NEW LEADER

Manufactured by

NEW LEADER MANUFACTURING

1330 76th Avenue SW | Cedar Rapids, Iowa 52404

information@newleader.com

www.newleader.com

Ph. 800.363.8281

Building the Best Since 1939

