



MODEL XZALT
Operator's/Parts Manual

UNIT SERIAL NO. _____

MANUAL NUMBER: 308216-H

EFFECTIVE 06/2023



1330 76TH AVE SW
CEDAR RAPIDS, IA 52404-7052
PHONE (800) 363-1771 | FAX (319) 286-3350
www.newleader.com

Copyright 2021 New Leader Manufacturing

Table of Contents	2
Interactive Features	5
Preface	7
Safety	8
Important Safety Information	8
Safety Alert Symbols	8
General Safety Rules	9
Safety Decals.....	19
Safety Decal Maintenance.....	19
Safety Decal Installation	19
Informational Decals	23
Installation Instructions	25
Hydraulic Requirements.....	25
Truck Requirements.....	25
Truck Frame Length.....	25
Controller Requirements	26
Dump Body Installation	26
Spreader Preparation	26
Loading	27
Securing Spreader.....	29
Removal From Dump Body	30
Truck Chassis Installation	31
Lifting the Spreader	31
Securing to Frame.....	32
Fender Installation.....	34
Hydraulic Hose Installation.....	35
Hydraulic Hose Installation Guide	36
Filling Hydraulic System.....	37
Hydraulic Connections.....	37
Electrical Connections	38
Vehicle Connections.....	38
Light Installation	38
Operations.....	39
Dimensions & Capacities	40
Initial Startup.....	42
Spinner.....	43
Storage Position	43
Spreading Position	44
Drop Point.....	44
Setting Spinner Height	45
Filling Hopper.....	47
Tarp.....	47
Liquid System	48
Liquid Valve.....	48
Filling Liquid Tanks.....	48
Metering Gate	50
Spreading Procedure	50
Manual Operation	51
Post-Spread	52
Spread Rate Limits.....	53
Typical Liquid Densities	54
Preventative Maintenance Pays!	55
Hydraulic System.....	55



Table of Contents Continued

Maintenance	55
Hydraulic Hose	56
Electrical System.....	57
Liquid System	57
Liquid Pump.....	57
Suction Strainer	57
Belt Conveyor.....	58
Tension	58
Tracking.....	58
Wiper Brushes	59
Cleaning Under Conveyor	59
Conveyor Gearcase.....	59
Sensors.....	60
Spinner Speed Sensor	60
Spinner Up Sensor.....	61
Low Gate Sensor	61
Dry Out Sensor	61
Lubrication of Bearings.....	62
Fasteners.....	62
Clean-Up.....	62
Lubricant & Hydraulic Oil Specifications	63
Hydraulic System	63
Gearcase Lubricant	63
Grease Gun Lubricant.....	63
Lubrication & Maintenance Chart	64
Standard Torques.....	66
Troubleshooting.....	67
Sensor Troubleshooting.....	68
Chute Down Sensor	68
Liquid Speed Sensor.....	69
Spinner Speed Sensor	70
Low Liquid Sensor.....	72
Conveyor Speed Sensor	74
Controller Operations.....	75
Not Functioning in Closed Loop	75
Spinner Does Not Move	76
Function Does Not Achieve Desired Rate	77

Table of Contents Continued

Parts	79
Tarp	80
Screens	84
Ladder	85
Light - Strobe/Beacon	86
Dump Body Mount Safety Strap	87
Subframe	88
Truck Chassis Mount Subframe	91
Chassis Mounts	92
Fenders - 100" Wide	93
Conveyor Group	94
Belt Shields.....	97
Spinner Pivot.....	99
Spinner Assembly.....	100
Lower Spinner Assembly.....	104
Chute Assembly.....	106
Spinner Disc	108
Spinner Flood Light.....	109
Liquid Pump System.....	110
Liquid Pump System - High Volume	115
Liquid System Hose Group.....	120
Liquid System Hose Group - High Volume.....	121
Fill/Pump Valve Assy.....	122
Fill/Pump Valve Assy - High Volume	123
3-Way Valve Assy	124
Liquid Tank Group	125
Liquid Tank Hose Group	128
Metering Gate Assy.....	129
Metering Gate Mechanism.....	130
Electronics System Enclosure Group	131
Controller	132
Control Panel Group	134
Decals	136
Hydraulic System	138
Hydraulic Truck Kit.....	140

NOTE:

This manual incorporates several interactive features to provide supplemental information and ease of navigation. The information below is to aid in the identification and use of these features.

Hyperlinks

Hyperlinks provide direct access to a specific destination when clicked. The entire Table of Contents of this manual is hyperlinked to provide quick access to all sections of this manual when viewing the electronic version.

Hyperlinks within the content are denoted by **blue, bold underlined text**. Electronic format viewers can click these links for direct access to New Leader online features. Internet access is required.

Insert Current HI-WAY Warranty

PLEASE ! ALWAYS THINK SAFETY FIRST !!

The purpose of this manual is to familiarize the person (or persons) using this unit with the information necessary to properly install, operate, and maintain this system. The safety instructions indicated by the safety alert symbol in the following pages supersede the general safety rules. These instructions cannot replace the following: the fundamental knowledge that must be possessed by the installer or operator, the knowledge of a qualified person, or the clear thinking necessary to install and operate this equipment. Since the life of any machine depends largely upon the care it is given, we suggest that this manual be read thoroughly and referred to frequently. If for any reason you do not understand the instructions, please call your authorized dealer or our Product Sales and Support Department at 1-888-363-8006.

It has been our experience that by following these installation instructions, and by observing the operation of the spreader, you will have sufficient understanding of the machine enabling you to troubleshoot and correct all normal problems that you may encounter. Again, we urge you to call your authorized dealer or our Product Sales and Support Department if you find the unit is not operating properly, or if you are having trouble with repairs, installation, or removal of this unit.

We urge you to protect your investment by using genuine HECO parts and our authorized dealers for all work other than routine care and adjustments.

New Leader Manufacturing reserves the right to make alterations or modifications to this equipment at any time. The manufacturer shall not be obligated to make such changes to machines already in the field.

This Safety Section should be read thoroughly and referred to frequently.

ACCIDENTS HURT !!!

ACCIDENTS COST !!!

ACCIDENTS CAN BE AVOIDED !!!

Important Safety Information

▲ WARNING

Before using this equipment, read, understand and follow all instructions in the Operator's Manual provided with this equipment. If the user and/or assistants cannot read or understand the warnings and instructions, the employer of the user and/or assistants must provide adequate and necessary training to ensure proper operation and compliance with all safety procedures pertaining to this equipment. If Operator's Manual has been lost, visit www.newleader.com or call your authorized dealer or our Product Sales & Support Department at (800) 363-1771 for replacements. Serious injury or death can result from the failure to read, understand, and follow instructions provided in this manual.

Figure 1.1 - The need for safety cannot be stressed strongly enough in this manual. At New Leader Manufacturing, we urge you to make safety your top priority when operating any equipment. We firmly advise that anyone allowed to operate this machine carefully read, learn and understand all messages and information in this manual and on machine's safety decals before operating machine, as well as familiarize themselves with the location and function of all machine controls.

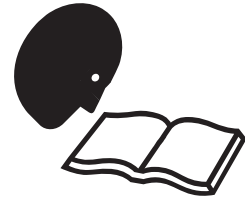

Figure 1.1

The following guidelines are intended to cover general usage and to assist you in avoiding accidents. There will be times when you will run into situations that are not covered in this section. At those times the best standard to use is common sense. If, at any time, you have a question concerning these guidelines, please call your authorized dealer or our Product Sales & Support Department at (800) 363-1771.

Safety Alert Symbols



Take note! This safety alert symbol found throughout this manual is used to call your attention to instructions involving your personal safety and that of others. Failure to follow these instructions can result in injury or death.

In this manual and on the safety signs placed on the unit, the words "DANGER," "WARNING," "CAUTION," and "NOTICE" are used to indicate the following:

▲ DANGER

DANGER indicates a hazardous situation which, if not avoided, will result in death or serious injury.

▲ WARNING

WARNING indicates a hazardous situation which, if not avoided, could result in death or serious injury.

▲ CAUTION

CAUTION indicates a hazardous situation which, if not avoided, could result in minor or moderate injury.

NOTICE

NOTICE is used to address practices not related to physical injury.

NOTE:

Provides additional information to simplify a procedure or clarify a process.

General Safety Rules

Operations

PREPARE FOR EMERGENCIES

Figure 1.2 - Be prepared if a fire starts. Keep a fully charged fire extinguisher and first aid kit in accessible place on the vehicle at all times.

Fire extinguisher must be Type ABC or Type BC.

Keep emergency numbers for doctors, ambulance service, hospital and fire department available at all times.

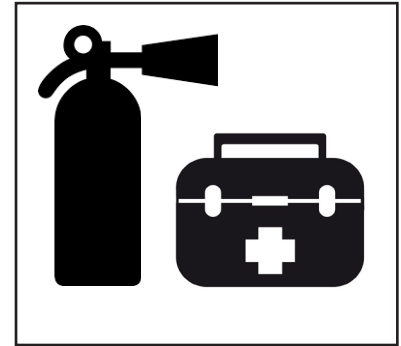

Figure 1.2

INSPECT HARDWARE BEFORE USE

Figure 1.3 - Inspect all bolts, screws, fasteners, keys, chain drives, body mounts and other attachments periodically. Immediately replace any missing or damaged parts with NLM specified parts.

Inspect spinner fins, spinner frame mounting and spinner fin hardware daily. Look for missing or loose fasteners, wear and cracks. Replace immediately with NLM specified parts.

Tighten all bolts, nuts and screws to specified torques. Refer to "Standard Torques" in Maintenance section of this manual.

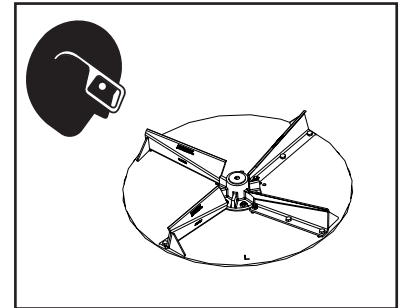

Figure 1.3

HANDLE FLAMMABLE MATERIALS SAFELY

Figure 1.4 - Handle fuel and hydraulic oil with care. They are highly flammable.

Exposure to toxic fluids or fumes may occur during the normal operation of this system. Before attempting to fill, use, or service this system, read Safety Data Sheets (SDS) to know the specific hazards of the fluids you are using. Always use proper Personal Protective Equipment when attempting to fill, use, or service this system.

Always stop engine before refueling machine or filling hydraulic reservoir.

Never smoke while adding fuel or oil to machine. Add fluids in a safe place away from open flame and sparks.

Do not allow overflow. Clean up spilled fuel and oil immediately.

Always have a multipurpose dry chemical fire extinguisher filled and available during machine operation and when adding fuel. Know how to use it.

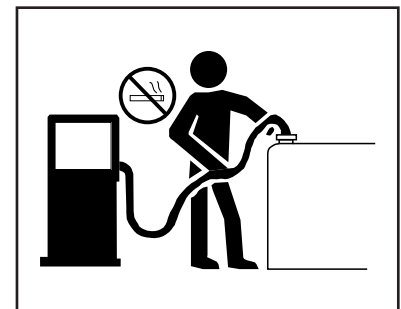

Figure 1.4

General Safety Rules

Operations

HANDLE HAZARDOUS MATERIALS SAFELY

Figure 1.5 - Materials to spread can be dangerous.

Improper selection, application, use or handling may be a hazard to persons, animals, plants, crops or other property.

A Safety Data Sheet (SDS) provides specific details on chemical products: physical and health hazards, safety procedures and emergency response techniques.

Check all SDS's before starting any job using a hazardous material. Follow all instructions and precautions given by the material manufacturer.



Figure 1.5

WORK IN WELL-VENTILATED AREAS

▲ WARNING	Never run machine engine inside a building unless adequate ventilation is provided to safely and properly remove exhaust fumes. Failure to comply with this requirement could result in death or serious injury.
------------------	--

Figure 1.6 - Always work in a properly ventilated area.

Engine exhaust fumes can cause sickness or death. If it is necessary to run an engine in an enclosed area, use proper equipment to safely remove exhaust fumes from the working area.

Open building doors and get fresh air into the working area whenever possible.



Figure 1.6

PROTECT AGAINST NOISE

Figure 1.7 - Long periods of exposure to high decibels or loud noise can cause hearing impairment or loss.

Wear proper hearing protection such as earmuffs or earplugs during periods of exposure to high decibels or loud noise.



Figure 1.7

General Safety Rules

Operations

AVOID MOVING PART HAZARDS

Figure 1.8 - Entanglement in rotating drive lines or moving parts will cause serious injury or death.

Stay clear of all moving parts, such as shafts, couplings and universal joints.

Make sure all personnel are clear of machine before starting.



Figure 1.8

Figure 1.9 - Do not operate machine without all guards and shields closed and secured.

Disconnect and lock out power source before removing guards.

Disconnect and lock out power source before adjusting or servicing.

Keep hands, feet, hair and clothing away from moving parts.

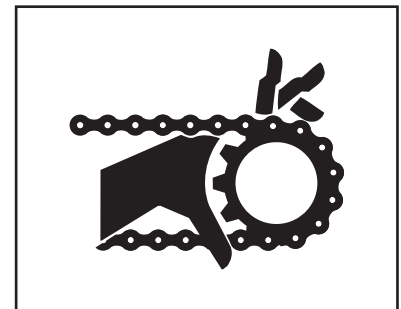

Figure 1.9

Figure 1.10 - Keep away from spinners while they are turning.

Rocks, scrap metal and other material can be thrown from the spinners violently. Stay away from discharge area.

Stop machine before servicing or adjusting. Wear eye protection.

Make sure discharge area is clear before spreading.

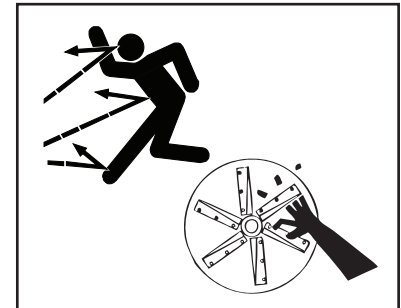

Figure 1.10

Figure 1.11 - Stay out of spreader.

If necessary to enter the spreader, return to shop, empty body, turn off all power, engage brakes, shut down engine and remove keys before entering.

Tag all controls to prohibit operation. Tags should be placed, and removed, by the person working in the body.

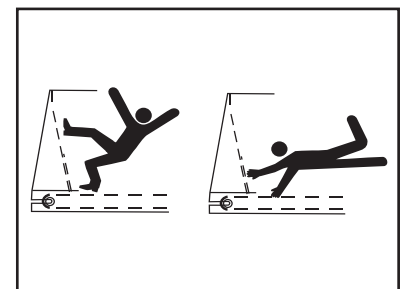

Figure 1.11

General Safety Rules

Operations

DO NOT CLIMB OR STAND ON MACHINE

Figure 1.12 - Never allow any personnel to ride in or on the machine.

Use inspection ladder or portable ladder to view the unit. Use caution when getting on and off the ladder, especially in wet, icy, snowy or muddy conditions. Clean mud, snow and ice from steps and footwear.

Always maintain three-point contact with steps, ladders and handholds. Face the machine when mounting and dismounting inspection ladder. Do not jump off machine.



Figure 1.12

OPERATE MACHINE SAFELY

Always walk around and visually inspect machine before using. Check the immediate vicinity of machine for people and obstructions. Ensure adequate visibility.

Avoid distractions such as reading, eating or operating personal electronics while operating machine. Never operate the machine under the influence of alcohol, drugs or while otherwise impaired.

Always come to a complete stop before reversing. Be sure that all personnel are clear of machine path. Turn around and look directly for best visibility. Ensure all rear view mirrors are properly installed and adjusted. Use a signal person when backing if view is obstructed or when in close quarters.

Always disengage hydraulics before shutting down engine. DO NOT start engine with hydraulics engaged.

General Safety Rules

Transportation & Handling

TRAVELING & TRANSPORTING ON PUBLIC ROADS

Always walk around and visually inspect the machine before traveling on public roads. Check for damage and/or faulty components that can fail and create a hazard or unsafe condition. Make sure all machine systems operate properly, including but not limited to: headlights, tail and brake lights, hazard warning lights, turn indicators, parking brake, horn and rear view mirrors. Repair or replace any component that is not in proper working order.

Never drive machine at a speed that causes it to bounce or cause loss of control.

Obey all traffic safety laws and regulations. Operate the machine with hazard warning lights on, unless prohibited by law. It is the operator's responsibility to activate and use road lights properly while traveling on public roads.

Cover all loads that may spill or blow away. Environmental damage may result. Do not spread dusty materials where dust may create pollution, visibility issues or interfere with traffic on public roads.

When transporting equipment or machine on a trailer, ensure it is properly secured. Be sure that SMV signs on equipment or machine are covered while in transport on a trailer.

Be aware of overhead structures and power lines. Make sure machine can safely pass under. Refer to "Dimensions & Capacities" pages in the Operations section of this manual.

NAVIGATING ROUGH & UNEVEN TERRAIN

Figure 2.1 - Turn slowly and be careful when traveling on rough surfaces and side slopes. Avoid holes, ditches and obstructions that may cause machine to roll over, especially with a loaded spreader.

Never drive near the edge of a gully or steep embankment.

Load may shift, causing vehicle to tip.

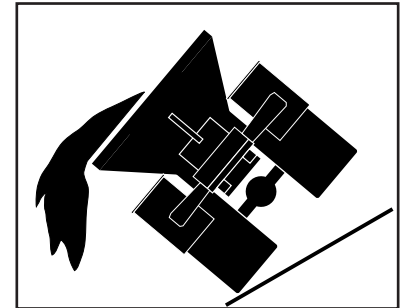

Figure 2.1

General Safety Rules

Maintenance

READ AND UNDERSTAND MAINTENANCE PROCEDURES

Figure 3.1 - Read the maintenance and safety instructions and understand them before performing any maintenance procedure.

Never perform any maintenance procedure or repair if the instructions and safety procedures are not fully understood. Only trained and qualified personnel should perform any maintenance procedure or repair.

Never modify any equipment or add attachments not approved by New Leader Manufacturing.

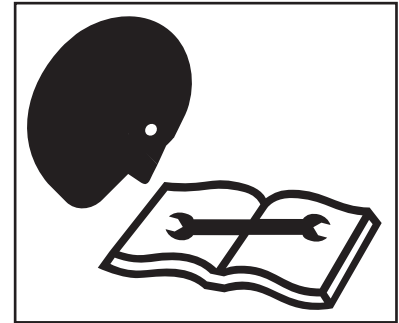

Figure 3.1

DO NOT SERVICE OR ADJUST MACHINE WHILE IN MOTION

Figure 3.2 - Never lubricate, service or adjust the machine or any of its components while they are moving.

Never wear loose clothing or jewelry when working near machine tools or moving parts.

Remove rings and other jewelry to prevent electrical shorts and other personal injury when in contact with machine tools or moving parts.

Close and secure all guards removed for service. Check all screws, bolts, nuts and fasteners for proper torques before operating machine.

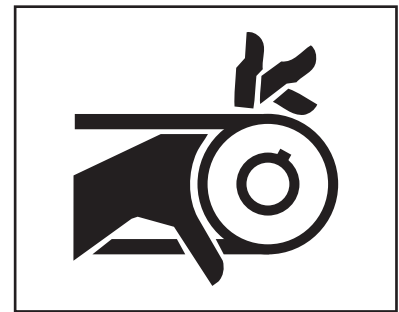

Figure 3.2

WEAR PROPER PROTECTIVE EQUIPMENT

Figure 3.3 - Wear close-fitting clothing and proper safety equipment for the job.

Always wear eye protection when working on or around the machine.

Wear a suitable hearing protection device such as earmuffs or earplugs to protect against high decibels or loud noises.

Prolonged exposure to high decibels or loud noise can cause hearing impairment or loss of hearing.

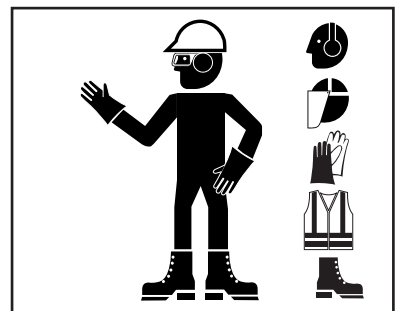

Figure 3.3

Wear protective gloves to protect hands from cuts, abrasions and minor burns.

General Safety Rules

Maintenance

HANDLE FLAMMABLE SOLVENTS SAFELY

Figure 3.4 - Never use diesel fuel, kerosene, gasoline or any flammable solvents for cleaning.

Exposure to toxic fluids or fumes may occur during the normal operation of this system. Before attempting to fill, use, or service this system, read Safety Data Sheets (SDS) to know the specific hazards of the fluids you are using. Always use proper Personal Protective Equipment when attempting to fill, use, or service this system.

Perform work using flammable fluids and solvents in a safe place away from open flame and sparks. Do not smoke.

Do not weld, grind or flame cut on any tank containing oil, fuel, fumes or any other flammable material, or any container that contents or previous contents are unknown. Move all flammable materials and containers away from work area.

Clean up spilled fuel and oil immediately.

Always have a multipurpose dry chemical fire extinguisher filled and available. Know how to use it.

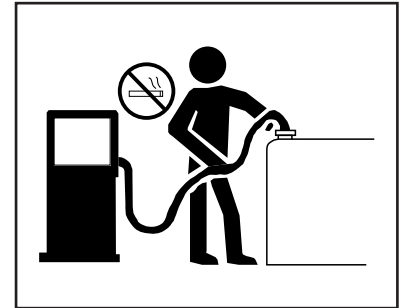

Figure 3.4

USE PROPER LIFTING EQUIPMENT

Figure 3.5 - Use only lifting devices that meet or exceed OSHA standard 1910.184 or ASME B30.20-2013.

Never lift equipment over people.

Never lift a loaded unit. Never lift unit with any loose objects or persons in the body. Loads may shift or fall if improperly supported, causing death, serious injury or machine damage.

Before unfastening heavy parts or assemblies, support with adequate hoist or other device to prevent falling, tipping, swinging or any other movement that may cause injury or damage.



Figure 3.5

USE PROPER TOOLS FOR THE JOB

Figure 3.6 - Use of improper tools (such as a screwdriver instead of a pry bar, pliers instead of a wrench, a wrench instead of a hammer) can cause serious injuries or machine damage.

Use power tools only to loosen threaded parts and fasteners. Using power tools to tighten may cause over-tightening and component damage.

Use only service parts meeting New Leader specifications.

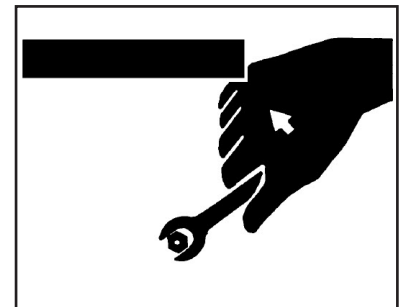

Figure 3.6

General Safety Rules

Maintenance

HIGH PRESSURE FLUID HAZARDS

Figure 3.7 - Escaping fluid under pressure can penetrate the skin causing serious injury.

Always stop machine, allow to cool and relieve pressure before servicing hydraulic system. Never open hydraulic lines under pressure. Make sure all connections are tight and all hoses are in good condition before pressurizing system.

Always use a piece of cardboard or wood to search for leaks instead of hand. Wear impervious gloves and eye protection when servicing system.

Seek medical attention immediately if fluid penetrates your skin. Gangrene may result if wound is left untreated.



Figure 3.7

AVOID HEATING NEAR HIGH PRESSURE FLUID LINES

Figure 3.8 - Flammable spray can be generated by heating near pressurized fluid lines, resulting in burns to yourself and bystanders.

Do not heat by welding, soldering or using a torch near pressurized fluid lines or other flammable materials.

Pressure lines can suddenly burst when heat goes beyond the immediate flame area.

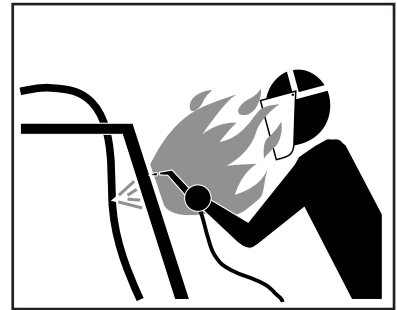

Figure 3.8

AVOID TOXIC FUMES & DUST

Figure 3.9 - Hazardous fumes can be generated when paint is heated from welding, soldering or using a torch.

Remove paint before heating:

- Remove a minimum of 4 in (100 mm) from area to be affected by heating. If paint cannot be removed, wear an approved respirator while heating or welding.
- Avoid breathing dust from sanding or grinding on paint.
- If a solvent or paint stripper is used, wash stripper away with soap and water before heating or welding. Remove solvent or paint stripper containers and other flammable material from area. Allow fumes to disperse for at least 15 minutes before heating or welding.

Do not use chlorinated solvents in areas where welding will take place.

Perform all work in a well-ventilated area that will carry all toxic fumes and dust away.



Figure 3.9

General Safety Rules

Maintenance

CLEAN MACHINE OF HAZARDOUS CHEMICALS

CAUTION

During application of hazardous chemicals, residue can build up on the inside or outside of the vehicle. Clean vehicle according to use instructions of hazardous chemical. Failure to comply with this requirement may result in minor or moderate injury.

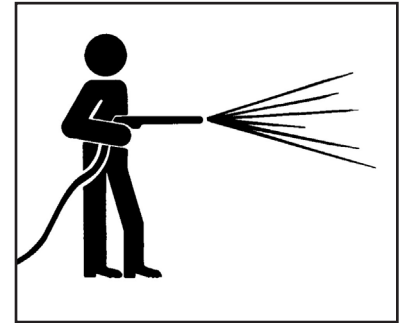

Figure 3.10

Figure 3.10 - When exposed to hazardous chemicals, clean exterior and interior of vehicle daily to keep free of the accumulation of visible dirt and contamination.

1. Clean operator's station to maintain unobstructed visibility of all windows and mirrors, and safe operation of all controls.

NOTICE

Directing pressurized water at electronic/ electrical components, bearings and hydraulic seals or other sensitive parts and components may cause product malfunctions. Reduce pressure and spray at 45 to 90 degree angles.

2. Wash entire exterior of vehicle.
3. Dispose of any wash water with hazardous concentrations of active or non-active ingredients according to published regulations or directives.

HANDLE BATTERIES SAFELY

WARNING

Sulfuric acid in battery electrolyte is poisonous. It can burn skin, eat holes in clothing, and cause blindness if it contacts eyes. Keep sparks and flame away from batteries. Wear proper safety equipment. Failure to comply with this requirement could result in death or serious injury.

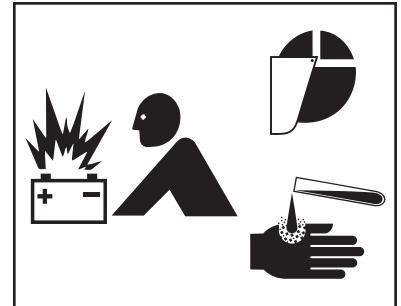

Figure 3.11

Figure 3.11 - Lead acid batteries generate flammable and explosive gases. Keep sparks and flame away from batteries. Do not smoke.

If acid contacts eyes, skin or clothing, flush with water immediately. Seek immediate medical attention if acid contacts eyes.

PROPER TIRE MAINTENANCE

Figure 3.12 - Never weld on a wheel or rim that has a tire on it.

Never attempt to mount or remove a tire unless using the proper equipment, tire safety cage, instructions, training, and you are qualified to perform the work safely. Failure to follow the correct procedures when mounting a tire on a wheel or rim can cause an explosion and serious injury.

Tire service procedures must be performed by trained and qualified personnel.

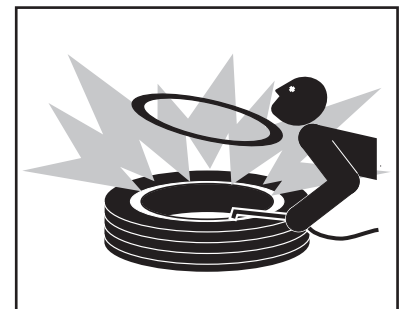

Figure 3.12

General Safety Rules

Storage

PARK VEHICLE SAFELY

Figure 4.1 - When leaving the vehicle unattended for any reason, be sure to:

- Shut down PTO.
- Shut off vehicle's engine, and unit's engine if applicable.
- Place vehicle transmission in "Neutral" or "Park".
- Set parking brake firmly.
- Remove ignition key and take it with you.
- Block wheels.

These actions are recommended to avoid unauthorized use, runaway, vandalism, theft and unexpected operation during startup.

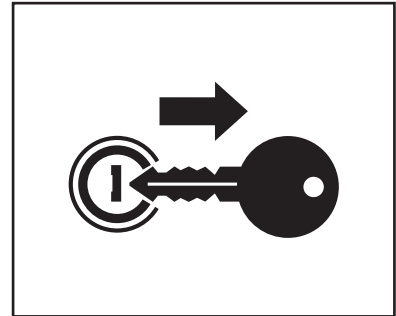

Figure 4.1

SUPPORT MACHINE PROPERLY

Figure 4.2 - When machine is removed from vehicle, always store on adequate supports on a firm level surface. Improper supporting or storage of spreader may cause machine to fall, resulting in serious injury or death.

Never use lifting device to free machine from a chassis, storage stands or frozen ground, or to lift the chassis in any way. Shock loading is prohibited and sudden accelerations must be avoided. Lifting in such a manner could result in injury or machine damage.



Figure 4.2

DISPOSE OF WASTE PROPERLY

Figure 4.3 - Improper disposal of waste can threaten the environment and ecology. Potentially harmful waste used with equipment include items such as fuel, oil, filters and batteries.

Use leakproof containers when draining fluids. Do not use food or beverage containers that may mislead someone into drinking from them. Do not pour waste onto the ground, down a drain, or into any water source.

Comply with all OSHA, local, City, State, Province, Country and jurisdiction regulations, ordinances and standards, related to your particular work area and environment. Inquire on proper disposal methods from your local environmental or recycling center, or from your local dealer.

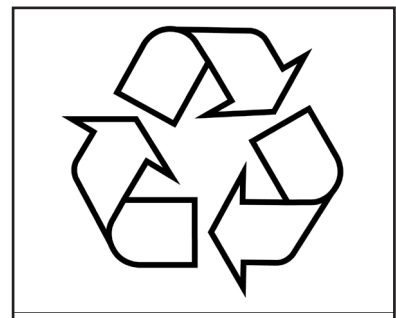

Figure 4.3

Safety Decals

Safety Decal Maintenance

Keep safety decals and signs clean and legible at all times.

Replace safety decals and signs that are missing or have become illegible.

Replaced parts that displayed a safety sign should also display the current sign.

Safety decals or signs are available from your dealer's Parts Department or from New Leader Manufacturing by calling (800) 363-1771.

Safety Decal Installation

Clean Surface

Wash the installation surface with a synthetic, free-rinsing detergent. Avoid washing the surface with a soap containing creams or lotion. Allow to dry.

Position Safety Decal

Decide on the exact position before application. Application marks may be made on the top or side edge of the substrate with a lead pencil, marking pen, or small pieces of masking tape. NOTE: Do not use chalk line, china marker, or grease pencil. Safety decals will not adhere to these.

Remove the Liner

A small bend at the corner or edge will cause the liner to separate from the decal. Pull the liner away in a continuous motion at a 180-degree angle. If the liner is scored, bend at score and remove.

Apply Safety Decal

Tack decal in place with thumb pressure in upper corners. Using firm initial squeegee pressure, begin at the center of the decal and work outward in all directions with overlapping strokes. NOTE: Keep squeegee blade even—nicked edges will leave application bubbles. Pull up tack points before squeegeeing over them to avoid wrinkles.

Remove Pre-mask

If safety decal has a pre-mask cover remove it at this time by pulling it away from the decal at a 180 degree angle. NOTE: It is important that the pre-mask covering is removed before the decal is exposed to sunlight to avoid the pre-mask from permanently adhering to the decal.

Remove Air Pockets

Inspect the decal in the flat areas for bubbles. To eliminate the bubbles, puncture the decal at one end of the bubble with a pin (never a razor blade) and press out entrapped air with thumb moving toward the puncture.

Re-Squeegee All Edges

! DANGER



PINCH POINT HAZARD
To prevent death or serious injury:

- Keep all persons and objects clear while any part of this machine is in motion.
- Keep hands, feet, hair and clothing away from moving parts.

55241-B



! DANGER

FLYING MATERIAL & ROTATING SPINNER HAZARD
To prevent death or serious injury:

- Wear eye protection.
- Stop machine before servicing or adjusting.
- Keep bystanders at least 60 feet away.

308192-B



! DANGER





MOVING PART HAZARD
To prevent death or serious injury:

- Stay out of box while conveyor is moving.
- Disconnect and lockout power source before adjusting or servicing.
- Do not ride on spreader.

364-C

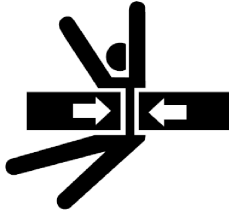
! DANGER



CRUSH HAZARD
To prevent death or serious injury:

- Do not stand between truck and spreader.
- Do not stand behind truck while in motion.

308194-B

! DANGER

GUARD IS MISSING WHEN THIS IS VISIBLE
To prevent death or serious injury:

- Do not operate this unit without guard in place.

308191-A





! WARNING

To prevent death or serious injury:

- Do not ride on ladder or fenders.

305274-B

 **WARNING**

HIGH PRESSURE FLUID HAZARD
To prevent death or serious injury

- Do not check leaks with hands while system is operating as high pressure oil leaks can be dangerous!
- Relieve pressure before disconnecting hydraulic lines or working on system.
- Make sure all hydraulic fluid connections are tight and all hydraulic hoses and lines are in good condition before applying pressure to the system.
- Wear protective gloves and safety glasses or goggles when searching for leaks. Use wood or cardboard instead of hands.
- Do not use hydraulic lines for hand holds or steps.
- Components may be hot.
- Get immediate medical attention if skin is pierced with fluid as gangrene may result.

39129-D

 **WARNING**

MOVING PART HAZARD
To prevent death or serious injury:

- Close and secure guards before starting.
- Do not stand or climb on machine.
- Disconnect and lockout power source before adjusting or servicing.
- Keep hands, feet and hair away from moving parts.

55631-C

 **WARNING**

FALLING SPINNER HAZARD
To prevent death or serious injury:

- Stay out from under spinner in raised position or while lowering hopper.
- Do not operate or transport in raised position.
- Keep away from rotating spinner.

71807-C

 **WARNING**



FALLING HAZARD
To prevent death, serious injury or machine damage:

- Do not stand or climb on guard.

308193-A

 **WARNING**



Failure to follow operating instructions could result in death or serious injury.

Read and understand operator's manual before using this machine.

308196-B

 **WARNING:** Cancer and Reproductive Harm-
www.P65Warning.ca.gov

315865-A

! CAUTION

HAZARDOUS MATERIALS
To avoid injury or machine damage:

- Materials to be spread can be dangerous.
- Improper selection, application, use or handling may be a hazard to persons, animals, crops or other property.
- Follow instructions and precautions given by the material manufacturer.

321-C

! CAUTION

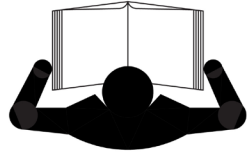

TO AVOID INJURY OR MACHINE DAMAGE:

- Do not operate or work on this machine without reading and understanding the operators manual.
- Keep hands, feet, hair and clothing away from moving parts.
- Do not allow riders on machine.
- Avoid unsafe operation or maintenance.
- Disengage power takeoff and shut off engine before removing guards, servicing or unclogging machine.
- Keep unauthorized people away from machine.
- Keep all guards in place when machine is in use.
- If manual is missing, contact dealer for replacement.

150034-C

METERING GATE
For desired material flow, move handle to proper position.

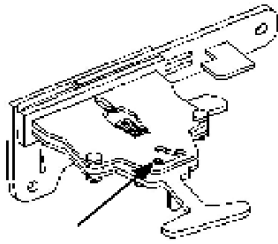
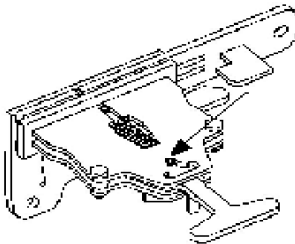
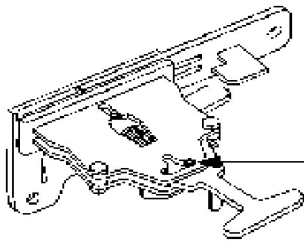
 HIGH	 LOW	 UNLOAD
--	---	--

308197-A

LIQUID VALVE
For desired fluid flow, move valve handle to proper position.

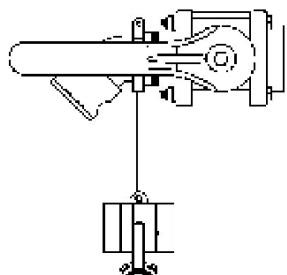
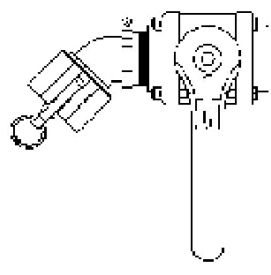
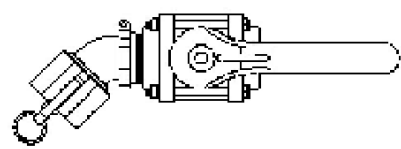
 FILL	 CLOSED	 RUN
---	---	--

308198-A

NO STEP

39017-D

This page is intentionally left blank.

INSTALLATION

Installation Instructions

Recommended sequence of installation is:

1. Mounting of PTO and pump.
2. Installation of radar (if applicable)
3. Mounting of spreader.
4. Installation of controller.
5. Installation of chassis hydraulic hose and electrical wiring to spreader.
6. Installation of optional parts.
7. Filling of hydraulic reservoir and lubrication.
8. Checking for leaks and proper functioning.

NOTICE

Pump and truck requirements must be determined prior to installation of the spreader.

Hydraulic Requirements

Hydraulics		GPM (LPM) (Gallons/Liters per Minute)	Maximum Pressure (PSI)
XZALT	Spinner & Conveyor	10 (38)	3000

The XZALT is intended to be a “plug and play” spreader. It is recommended to mount a suitable hydraulic quick disconnect system at the rear of the truck.

Truck Requirements

Before mounting the spreader on a truck, the following major questions must be considered:

1. Is the CA (Cab to Axle) dimension of the truck correct for the length of the spreader?

The Dimensions and Capacities chart in the operator’s manual will assist in matching spreader to truck.

2. Is the truck’s GAWR (Gross Axle Weight Rating) and the GVWR (Gross Vehicle Weight Rating) adequate to carry the fully loaded spreader, in addition to auxiliary equipment, such as plows, wings and scrapers?

Refer to your Hi-Way dealer to find the GAWR and GVWR for most trucks, and how to calculate the weight distribution on each axle and total loaded vehicle weight.

Truck Frame Length

Refer to “Dimensions & Capacities” section in the operator’s manual for approximate length from the rear of the cab to the rear end of the frame. Shorten truck frame as necessary, making sure to follow truck manufacturer’s specifications so as not to void truck warranty.

NOTICE

Do not weld to truck frame; it may void truck warranty.

If mounting the spreader directly to the truck frame, rather than inside a truck body, a level top surface is necessary for mounting. Add steel shim bars or strips the same thickness as fish plates or other obstructions and as wide as the truck frame channel top flange. Shims must be drilled to clear any rivet or bolt heads.



Controller Requirements

The spreader is intended for use with a FORCE America SSC6100 Spreader Control consisting of a display, core controller, operator pad, cabling and appropriate manuals. All controller system components and truck side cabling are available through FORCE America. The system must be installed per FORCE America standards and meet the following minimum requirements:

- The 6100 core module must be 94096 A001.
- The 6100 Firmware must be upgraded to version 0.38 or higher.
- The 6100 GEN3 system must be setup with an ESTOP Power Contactor and all power to the XZALT machine must be supplied through that contactor per FORCE America standards.

The controller system is connected to the spreader at the rear of the truck through an ISOBUS bulkhead connector supplied with the spreader. The Mixed Material Module which controls spreader functions is supplied with the spreader.

Dump Body Installation

Spreader Preparation

Roller Sidebars

The four roller sidebars are intended to guide the spreader along the sidewalls during loading and unloading. Settings on each side of the spreader must be equal to center spreader on the dump body.

NOTE: If the dump body has large radiused corners, the sidebars can be flipped to increase the height of the roller.

1. Measure the inside width of the dump body at the front just above any radiused corner.
2. Measure the distance between the two front rollers on the spreader as shown in Figure 1. Start from the outside edge of one roller and measure to the outside edge of the opposite roller.

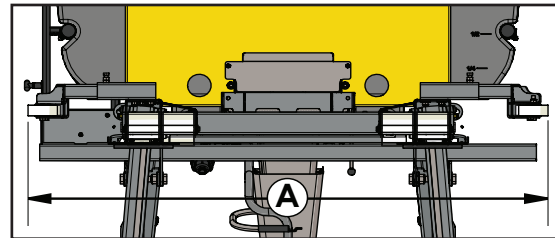

Figure 1 - Distance Between Front Rollers

3. Adjust the roller sidebars as necessary so distance between rollers is just less than the inside width of dump body:
 - a. Loosen the locknut (A) and bolt (B) on top of side bar.
 - b. Adjust roller sidebars as shown in Figure 2. Align bolt with sidebar hole.
 - c. Verify the distance between two front rollers. Adjust if necessary.
 - d. Tighten bolt so it is securely in sidebar hole.
 - e. Tighten locknut.

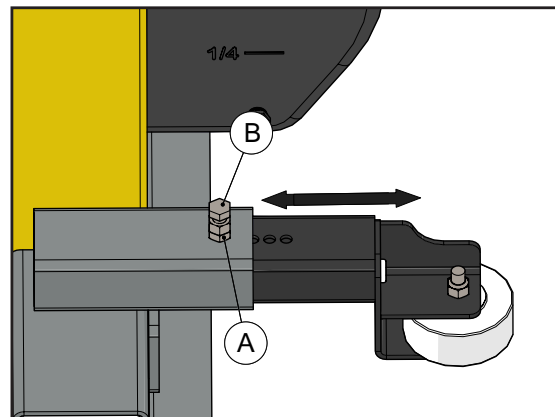

Figure 2 - Adjust Roller Sidebars

4. Repeat for the two rear roller sidebars.

Loading

The storage leg system is designed to be used where the dump body floor is between the height of 42" to 68". The height of the legs will need to be adjusted for first time use to match the dump body floor height. The legs should be adjusted so the spreader sits level or slightly elevated at the front.

Check to make sure the vehicle is suitable for the spreader. Consider all other auxiliary equipment such as front snow plows, wings and scrapper blades. Consider the total weight of the spreader, liquid and granular materials.

The dump body floor must be clear of sand, salt, snow, ice or any other debris and the four rubber pads should always contact the floor when the spreader is installed.

1. Raise loading platform approximately 10°.
2. Figure 3 - Back truck underneath spreader until dump body sides contact stopping flags and spreader's front leg supports leave the ground.

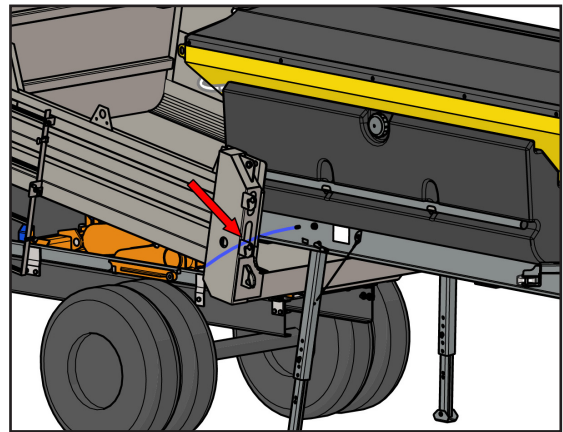

Figure 3 - Flag Stops

3. Apply truck's parking brake and chock wheels.
4. Figure 4 - Attach safety strap to chassis and tighten so strap is taut. Front legs remain locked.

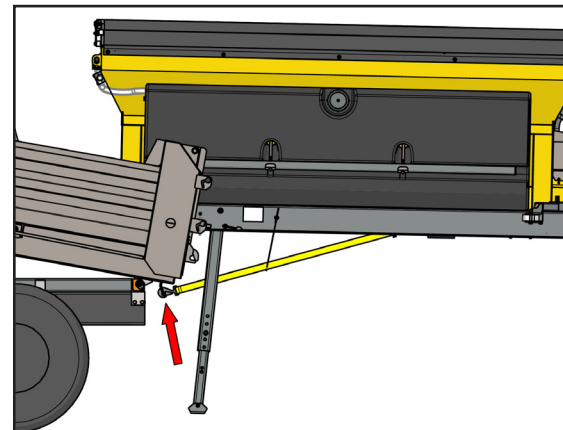

Figure 4 - Attach Safety Strap

- Figure 5 - Remove front leg supports' locking pins from hole as shown in Figure 6. Store locking pin in loop holder on side of frame.

Note: On high truck floors and short spreader bodies, the front legs may need to be shortened to fold up.

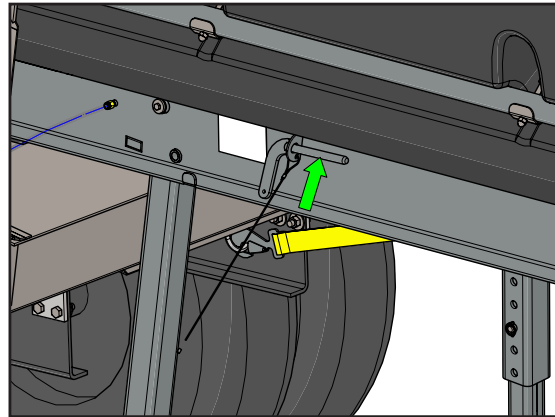

Figure 5 - Leg Support Lock Pin

NOTICE!

Spreader angle may need to be increased or decreased to properly position on truck.

- Figure 6 - Continue to back dump body underneath spreader until front leg supports fold up against edge of loading platform and truck makes contact with spreader.
- Apply truck's parking brake and chock wheels.

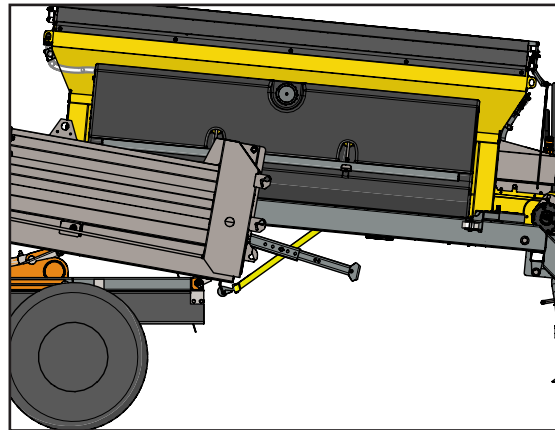

Figure 6

- Figure 7 - Lower the dump body completely. The rear legs should be off the ground.

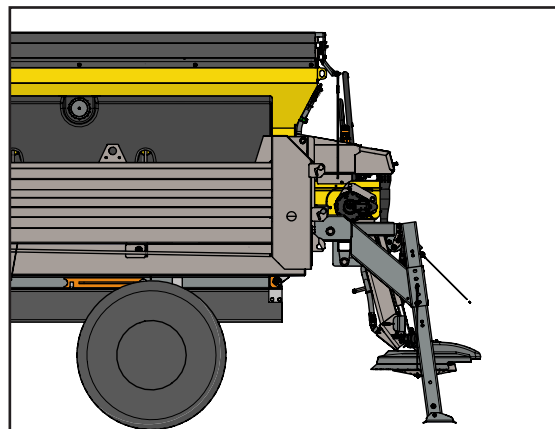

Figure 7

Installation Instructions

9. Figure 8 - Raise rear legs:
 - a. Remove lock pin (A).
 - b. Grip rear leg at handle (B).
 - c. Lift leg above the height of the spinner.
 - d. Insert lock pin into diagonal slot.

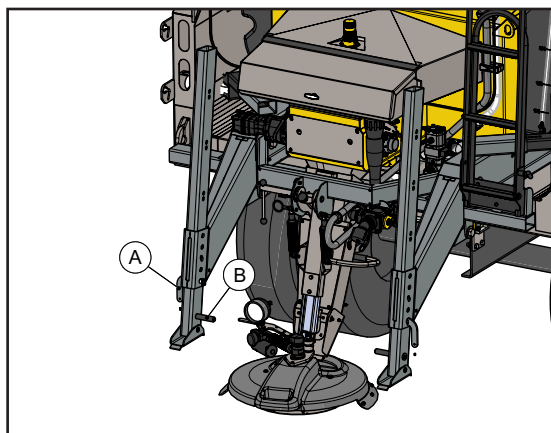

Figure 8 - Rear Leg detail

10. Secure spreader. See Securing Spreader section.
11. Hook up all connections between spreader and chassis.
 - Control Cable - See Vehicle Connections: Control System.
 - Hydraulics - See Vehicle Connections: Hydraulic Lines.

Securing Spreader

⚠ WARNING

Inspect securing devices and tie-down points for wear and tear. Replace securing device and repair tie-down points if any sign of wear or damage. Make sure securing devices do not contact sharp edges, moving or hot components. If securing device fails, spreader could slide causing damage or serious injury. Failure to comply with this requirement could result in death or serious injury.

Spreader must be secured to dump body to eliminate movement caused by braking, cornering and acceleration of truck. Operator is responsible for supplying and attaching appropriate securing devices as the spreader can be installed in many different types of dump bodies with a variety of tie downs. The Federal Motor Carrier Safety Administration may be used as a guide for securing loads.

Roller sidebars should be correctly positioned to restrict side-to-side movement.

⚠ CAUTION

Avoid sharp edges and corners when attaching straps to prevent personal injury. Failure to follow this requirement may result in injury or machine damage.

12. Figure 9 - Secure spreader to chassis and dump body with ratchet straps, mounting to the securing hooks located at each corner of the spreader, on the top and the sides.

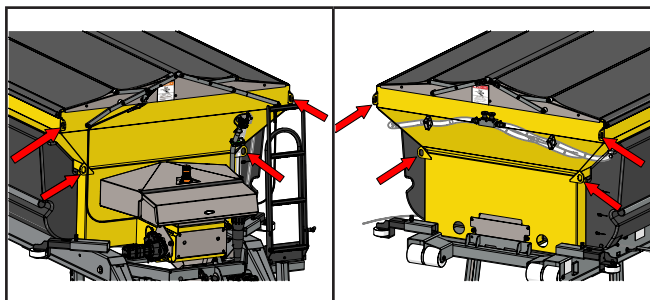

Figure 9

Removal From Dump Body

Reference illustrations on previous pages in reverse order as necessary.

1. Empty spreader of all liquid and granular materials.
2. Drive to level, firm surface to unload spreader. Take truck out of gear and set parking brake.
3. Disconnect all hydraulic and electrical connections from spreader to truck.
4. Remove (8) ratchet straps at upper corners of spreader hopper to truck.
5. Lower rear legs of spreader to approximately 1" (5cm) from ground and lock in position.
6. Ensure safety strap on bottom side of spreader is still connected to dump body.
7. Raise dump body approximately 10°, so the spreader's rear legs touch the ground and the rubber pads lift off of the dump body floor.
8. Drive truck forward, sliding spreader out of box until front legs fold down.
9. Take truck out of gear, set parking brake and chock wheels.
10. Set front legs approximately 1" (5cm) from ground and lock in position. Secure in upright position with locking pin through subframe.
11. Unhook safety strap from truck.
12. Slowly drive truck out from under spreader. Lower dump body.

Truck Chassis Installation

Lifting the Spreader

⚠ WARNING

Use only lifting devices that meet or exceed OSHA standard 1910.184 or ASME B30.20-2006. Never lift equipment over people. Never lift unit with anything or anybody in the body. Loads may shift or fall if improperly supported. Failure to comply with this requirement could result in death or serious injury.

⚠ CAUTION

Do not use lifting device to free unit from a chassis, storage stands or frozen ground, or to lift the chassis in any way. Shock loading is prohibited and sudden accelerations should be avoided. Failure to follow this requirement may result in injury or machine damage.

Always inspect unit lift points for signs of wear, cracking, corrosion, gouges, alterations, or distortion.

Always use a sling, spreader bar, or lifting bar that attaches to the lifting points with a minimum of 60 degrees from horizontal. It is preferable to use an "H" style lifting bar that keeps the attaching chains in a near vertical orientation as shown in Figure 1. Operators of lifting devices must be qualified and knowledgeable in their use and application.

Position the chassis with adequate room around the unit. Work in an environment that permits clear communication to others nearby. Keep area clear of persons when loads are to be lifted and suspended. Do not allow the lifted load to come in contact with any obstruction.

Store units on a solid surface using appropriate storage stands when not installed.

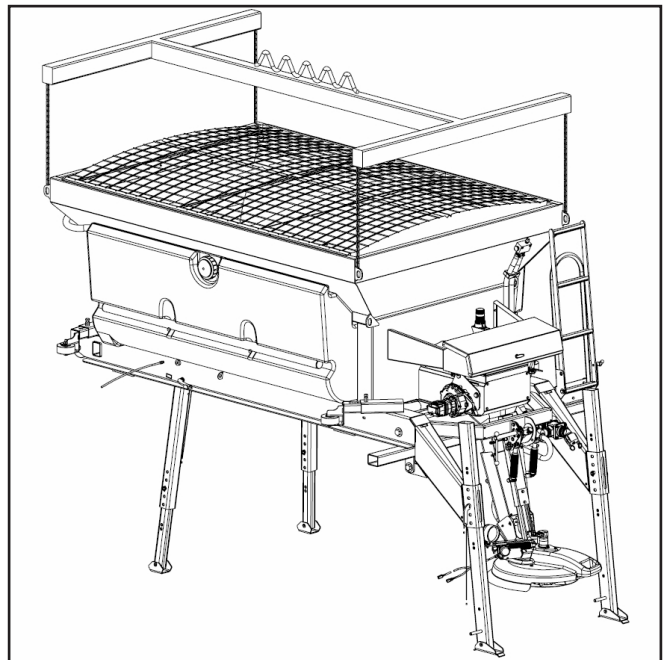

Figure 1 - Lifting Bar

Securing to Frame

CAUTION Be careful when drilling so as to not damage truck frame, fuel tank, or any other important components. Failure to follow this requirement may result in injury or machine damage.

NOTICE DO NOT WELD ON VEHICLE FRAME! Such welding can lead to fatigue cracking and must be avoided.

NOTICE DO NOT PUT HOLES INTO TOP OR BOTTOM FLANGES—to do so may void truck manufacturer's warranty. When drilling holes in frame member, drill only through vertical web portions.

NOTICE Connect welders ground directly to one of the items being welded anytime an arc welder is used on the vehicle or anything connected to the vehicle. Refer to Manufacturer's instructions.

IMPORTANT! Disconnect electrical components from electrical system when welding on equipment to prevent component damage due to power surges or excessive current.

Front Mount Angles

Assemble two front mounting angle springs and hardware. Use a 3/8" (10mm) shim between cross tube mounting plate and truck frame mounting angle. Position assembly ahead of front subframe mount and against truck frame, make sure springs do not contact subframe. Mark position of mounting angle holes on truck frame. Drill 9/16" (14mm) holes where marked and install mounting assembly using 1/2" hardware supplied. Weld mounting plate to side of subframe on three sides, and remove 3/8" (10mm) shim (Figure 2). Tighten spring assembly until spring compressed height is 4" (102cm). There should be a 3/8" (10mm) space between cross tube mounting plate and truck frame mounting angle (Figure 2). Repeat this procedure on other side of truck frame, directly across from opposite mount.

Rear Mount Plates

Rear mounting plates are not factory supplied. Fabricate mounting plates out of 1/4" steel plate. The mounts must provide sufficient area to weld to XZALT subframe and to bolt to truck frame with four 1/2" grade 8 (13mm 10.9) bolts per side. See Figure 2 for example guidelines.

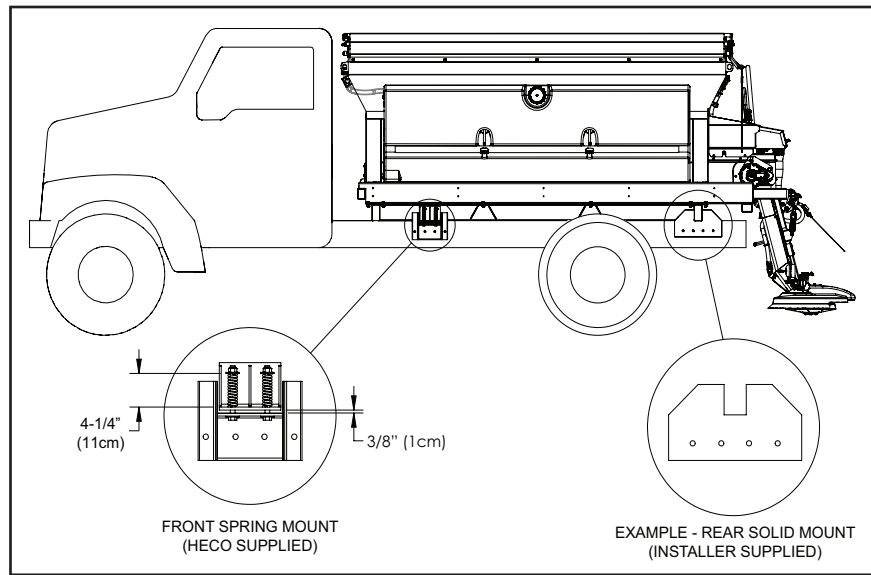

Figure 2 - Mounting Angle Installation

Mounting Angle Installation

Install mounting angles and tighten mounting bolts to recommended torque. Weld mounting angles to spreader subframe by welding on front, outer and rear sides. Make sure welds between mounting angles and spreader subframe are sound full fillet welds. Center mounting angles so full fillet welds can be made on three sides. An edge bead weld is not a satisfactory weld for this service. Use E70S rod/wire for carbon steel to carbon steel and 309 rod/wire for carbon steel to stainless steel. Use 309 rod/wire to weld stainless steel to stainless steel.

Fender Installation

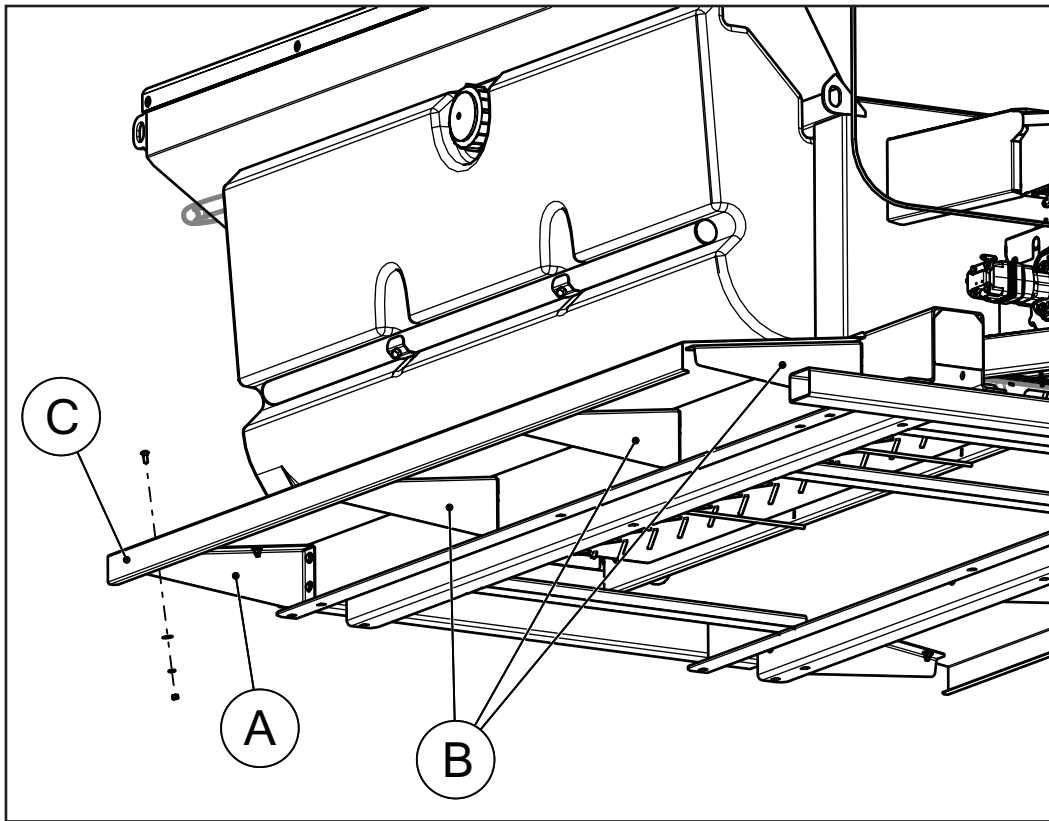

Figure 3 - Fender Installation

1. Figure 3 - Install front fender angles (A) on each side of subframe with bolt flanges pointing rearward.
2. Install all following fender angles (B) with bolt flanges pointing forward.
3. Install cap screw hardware hand tight.
4. Place fender (C) on fender angles. Align bolt holes and install carriage bolt hardware.
5. Tighten all hardware to recommended torque.

Hydraulic Hose Installation

⚠ CAUTION

If a threaded connection is tightened too tightly, the fitting or housing into which the fitting is placed could be distorted and an unstoppable leak could occur. Failure to follow this requirement may result in injury or machine damage.

⚠ WARNING

Do not use one manufacturer's hose with another manufacturer's fittings! Such will void any warranty and may cause premature burst or leak of hydraulic fluids! Severe injury and/or fire could result! Failure to comply with this requirement could result in death or serious injury.

Determine pressure port of pump. Install pressure hose into this port. Connect suction hose to opposite port and to tank outlet on hydraulic tank. Use plastic tie straps as necessary to support hoses so they will not catch on field obstructions or contact hot or moving parts.

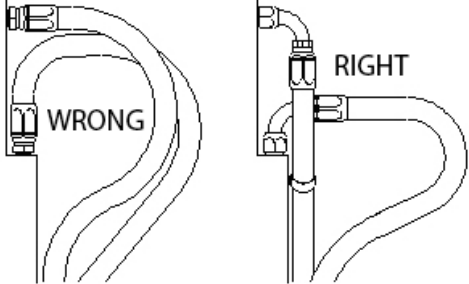
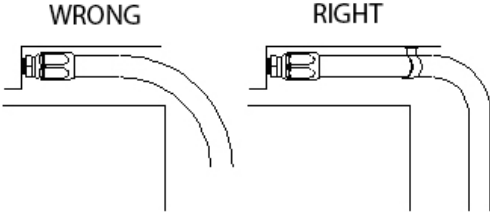
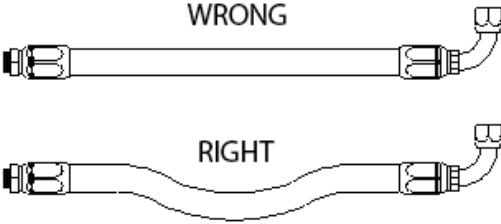
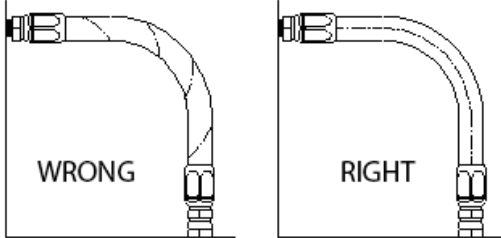
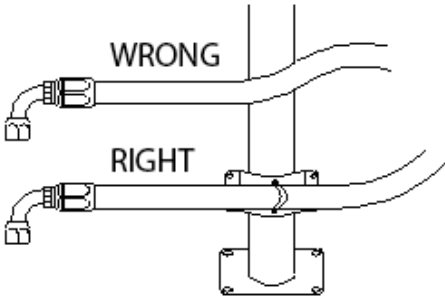
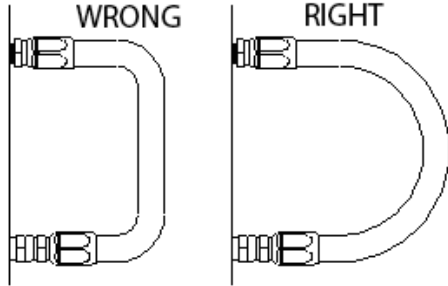

Hydraulic Hose Installation Guide

	
<p>1. Use elbows and adapters in the installation to relieve strain on the assembly, and to provide easier and neater installations that are accessible for inspection and maintenance. Remember that metal end fittings cannot be considered as part of the flexible portion of the assembly.</p>	<p>2. Install hose runs to avoid rubbing or abrasion. Clamps are often needed to support long runs of hose or to keep hose away from moving parts. It is important that the clamps be of the correct size. A clamp that is too large will allow the hose to move in the clamp causing abrasion at this point.</p>
	
<p>3. In straight hose installations allow enough slack in the hose line to provide for changes in length that will occur when pressure is applied. This change in length can be from +2% to -4%.</p>	<p>4. Do not twist hose during installation. This can be determined by the printed layline on the hose. Pressure applied to a twisted hose can cause hose failure or loosening of the connections.</p>
	
<p>5. Keep hose away from hot parts. High ambient temperature will shorten hose life. If you cannot route it away from the heat source, insulate it.</p>	<p>6. Keep the bend radii of the hose as large as possible to avoid hose collapsing and restriction of flow. Follow catalog specs on minimum bend radii.</p>

(Used with the permission of The Weatherhead Company.)

Hydraulic Connections

The hydraulic valve, located in enclosure at rear of spreader, connects to truck via the two hoses listed below (Figure 8). Hoses are provided with the spreader but should be fitted with quick connects provided and installed by dealer on truck. Refer to Figure 9 and the "Hydraulic Schematic" page in the Troubleshooting section of this manual.

HOSE	PART NUMBER	DIMENSIONS
Pump	308206	.5 x 108
Tank	308207	.75 x 108

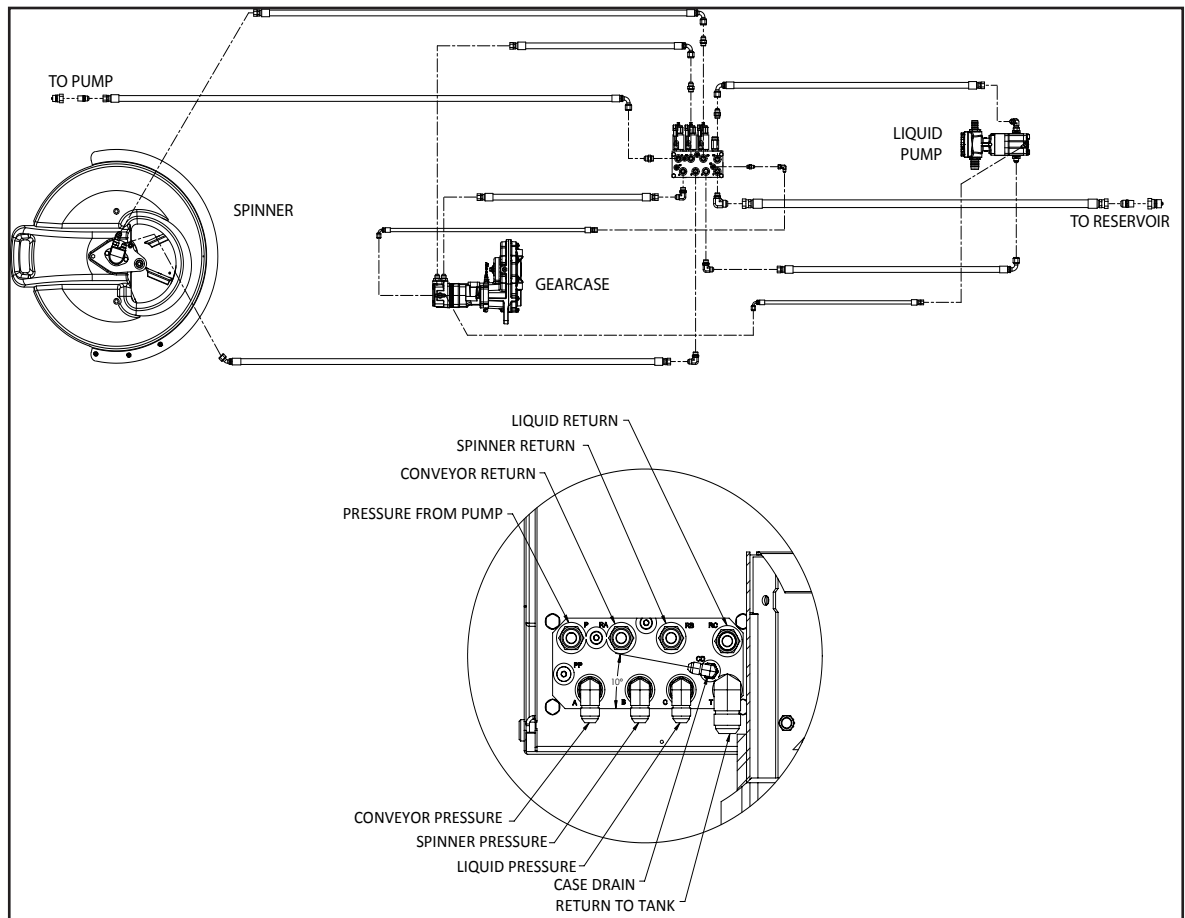

Figure 4 - Hydraulic System and Valve

Filling Hydraulic System

NOTICE DO NOT attempt to run pump without first filling hydraulic reservoir and opening suction line valve, or damage to pump may occur.

Fill reservoir with hydraulic oil as specified in the "Lubrication and Maintenance" section in the operator's manual. Be sure oil is clean, free from dirt, water and other contaminants.

Lubricate all points necessary per Lubrication Chart in "Lubrication and Maintenance" section of operator's manual.



Electrical Connections

Connect all electrical control circuits. All wiring should be approved automotive insulated wire, supported adequately with insulating ties or straps, and located where it will not interfere with any control or access. Make sure wiring does not contact any moving parts or sharp edge and is kept away from any hydraulic line or any heated part.

Vehicle Connections



If a threaded connection is tightened too tightly, the coupling or housing into which the coupling is placed could be distorted and an unstoppable leak could occur. Failure to follow this requirement may result in injury or machine damage.



Do not use one manufacturer's hose with another manufacturer's fittings! Such will void any warranty and may cause premature burst or leak of hydraulic fluids! Failure to comply with this requirement could result in death or serious injury.

The spreader utilizes the Force America 6100 control system to control spreader functions.

Figure 8 - Attach cable on spreader, shown in Figure 8, on spreader to Powell ISOBUS bulkhead connector, on rear of truck.

Refer to control system's operation manual, as well as "Electronics System" in parts manual for further instructions.

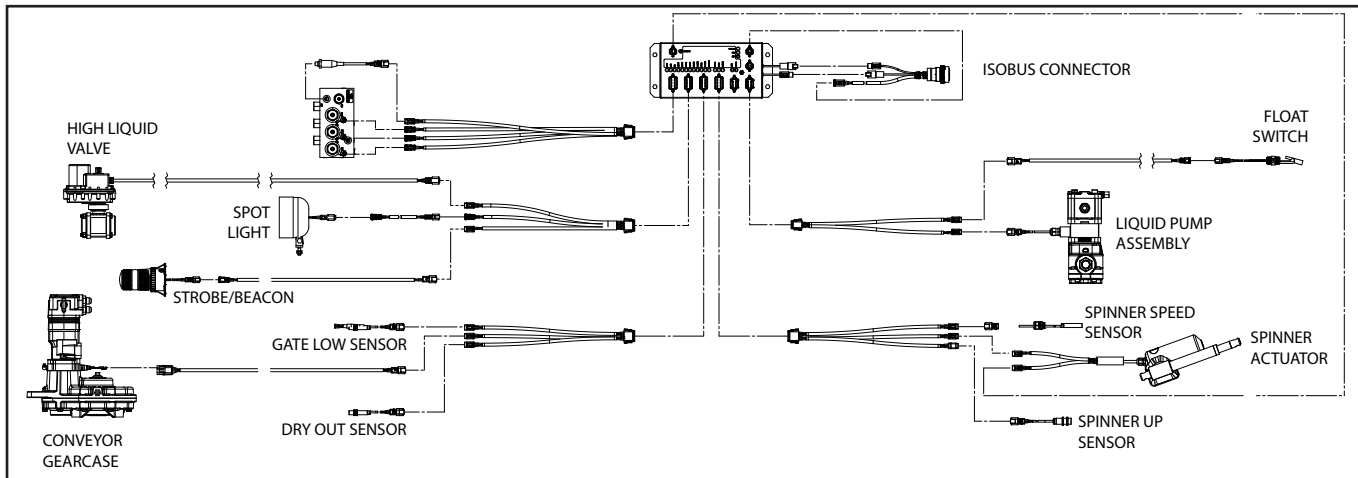

Figure 5 - Electrical System

Light Installation



All holes in truck cab walls, floor and firewall are to be grommeted, plugged and sealed to prevent entrance of engine fumes, dust, dirt, water and noise. Failure to follow this requirement may result in injury or machine damage.

Light installation must comply with all applicable requirements prescribed by FMVSS/CMVSS 108, ASABE S279, state and local regulations. See Light's parts page in the operator's manual for illustrations if applicable.

OPERATIONS

Operations

General Description

The XZALT is a hopper-type spreader with direction control intended for accurate and even spreading of material for snow and ice control. Material combines with liquid at a high 70% salt to 30% de-icing solution ratio, such as salt brine or calcium chloride. This provides for better granular salt activation, less material bounce and better placement control. The unit can also spread dry sand.

The XZALT is available in two mounting options: dump body mount and direct chassis mount. The dump body mount option is intended to slide into a dump truck body for quick and easy installation. No cranes are required to install this option. The dump body mount XZALT utilizes a galvanized subframe with nylon rollers for ease of installation, and galvanized retracting storage legs for when not in use. The direct chassis mount option utilizes a galvanized subframe to conventionally mount the unit directly to the truck chassis. Optional truck fenders are available.

The unit is powered hydraulically, providing independent, variable speed control for the spinner, conveyor and liquid system flow. The control provides on-the-go adjustment of directional spinner allowing placement of mixture where needed. The spreader is intended for use with the FORCE® America, Inc. SSC6100 Spreader Control.

The endless cleated belt conveyor runs the full length of the hopper bottom to deliver material to the spinner through a metering system at the rear of the hopper body.

The spinner sits below the unit and locks in an upright position when not in use or unloading. Material can be spread from 6 to 36 ft., or up to three lanes wide. Material moves from the hopper, down the chute and onto the spinner. Liquid is mixed with the granular material at the end of the chute and on the spinner disc assembly. Spinner height is set independently by changing the length of the chute.

The preset metering door can break up clumps, preventing blockage. Bolt-in, galvanized screens also limit material clump size.

This product is intended for use by trained personnel only.



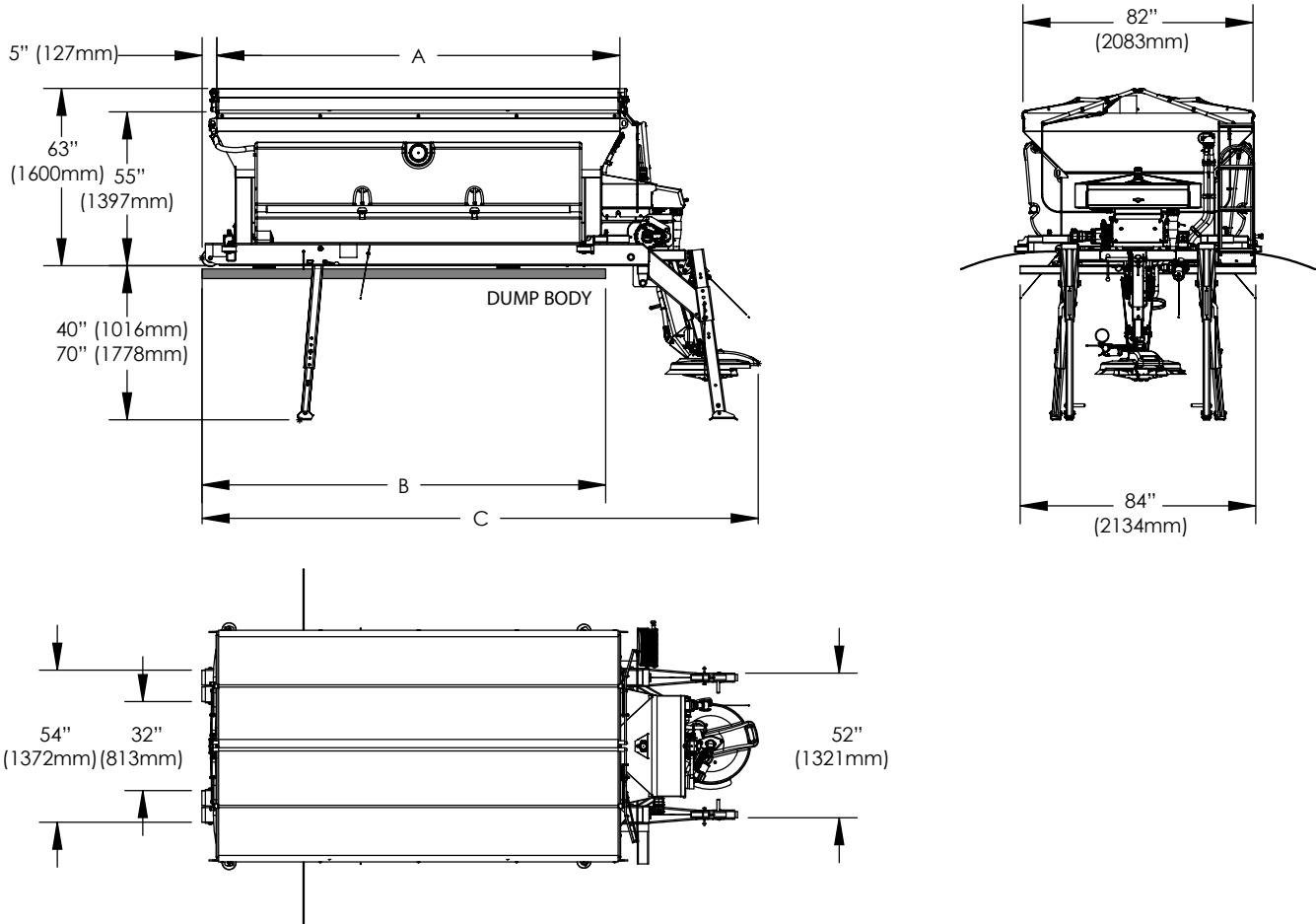

IMPORTANT!

Please consult federal, state, and local weight laws and chassis manufacturer's ratings to ensure neither government weight restrictions nor GVWR and GAWR's are exceeded. Tire and tandem axle size may require mounting modification of optional mud flaps.

Dimensions & Capacities Continued

Unit Length	10' (3.05m)	12' (3.66m)	14' (4.27m)
Inside Length A	120" (3048mm)	144" (3658)	168" (4267mm)
Minimum Dump Body Length (Box Mount) B	10' (3.05m)	12' (3.66m)	14' (4.27m)
Overall Length C	174" (4420mm)	198" (5029mm)	222" (5639mm)
Approximate Weight lbs (kg)	3400 (1542)	4000 (1814)	4500 (2041)
Struck Capacity Cu Ft (Cu m)	141 (4)	172 (4.9)	202 (5.7)
Rounded Capacity Cu Ft (Cu m)	167 (4.7)	205 (5.8)	242 (6.9)
Liquid Capacity Gal (L)	464 (1756)	594 (2249)	724 (2741)



⚠ WARNING

DO NOT check leaks with hands while system is operating as high pressure oil leaks can be dangerous! If skin is pierced with hydraulic fluid at high pressure seek immediate medical attention as fluid injected into the skin could cause gangrene if left untreated. Relieve pressure before disconnecting hydraulic lines or working system. Make sure all hydraulic fluid connections are tight and all hydraulic hoses and lines are in good condition before applying pressure to the system. Wear protective gloves and safety glasses or goggles when working with hydraulic systems. Failure to comply with this requirement could result in death or serious injury.

⚠ WARNING

DO NOT check for leaks adjacent to moving parts while system is operating as there may be danger of entanglement! Failure to comply with this requirement could result in death or serious injury.

Spinner

CAUTION

Spinner is counterbalanced to aid lifting. Do not stand under spinner when raising or lowering. Falling spinner can cause injury. Do not adjust spinner position when machine is operating to avoid entanglement, causing injury or death.

Storage Position

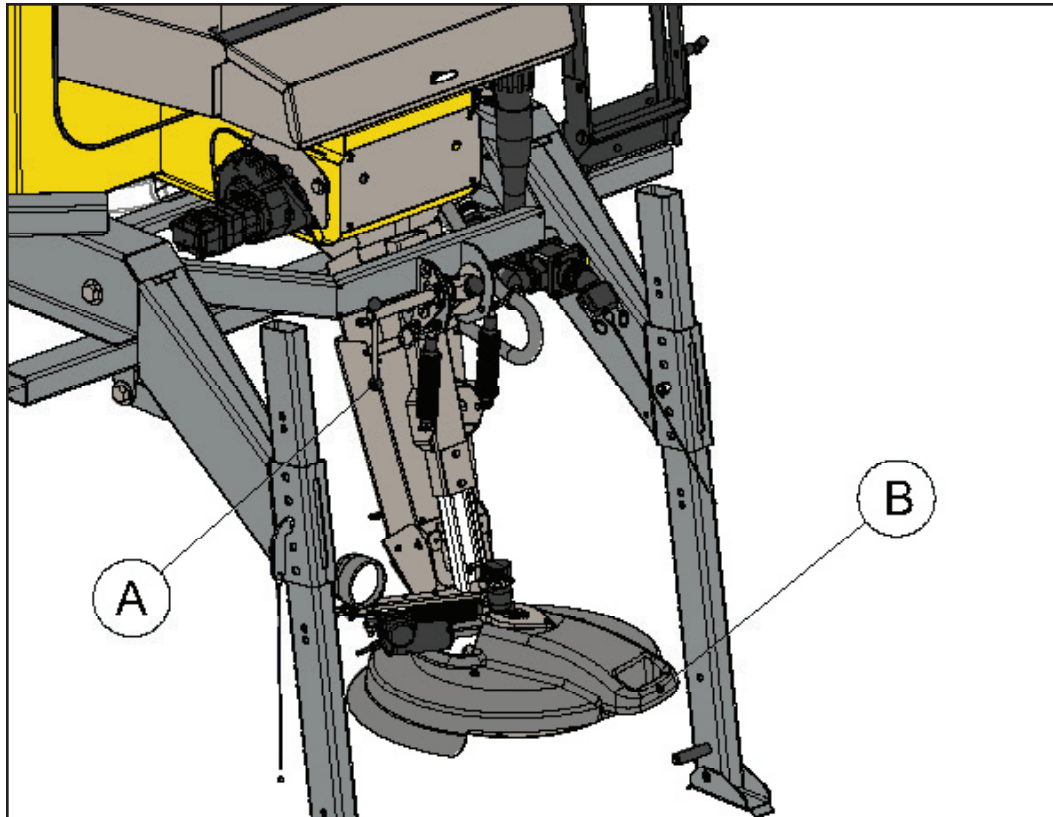

Figure 1

Spreading Position

1. Loosen clamp two full turns.
2. Grip handle on back of chute and begin to lower the spinner assembly.
3. Use spinner hood handle to finish lowering system until it can't go any further.
4. Tighten clamp. Clamp must be tightly closed for spinner to operate.

Drop Point

The drop point, or point on the spinner cone at which the bottom part of the chute is aimed, must be set to 1-3/16" (30mm) above the spinner disc, \pm 3/16" (5mm).

1. Position spinner to produce a symmetrical spread pattern, such as 3' left hand and 3' right hand..
2. Hold a flat strip or equivalent flush against inside, bottom of chute with the strip's bottom touching the spinner hub.
3. Figure 2 - Measure the distance between where the strip hits the spinner hub and the base of the hub.

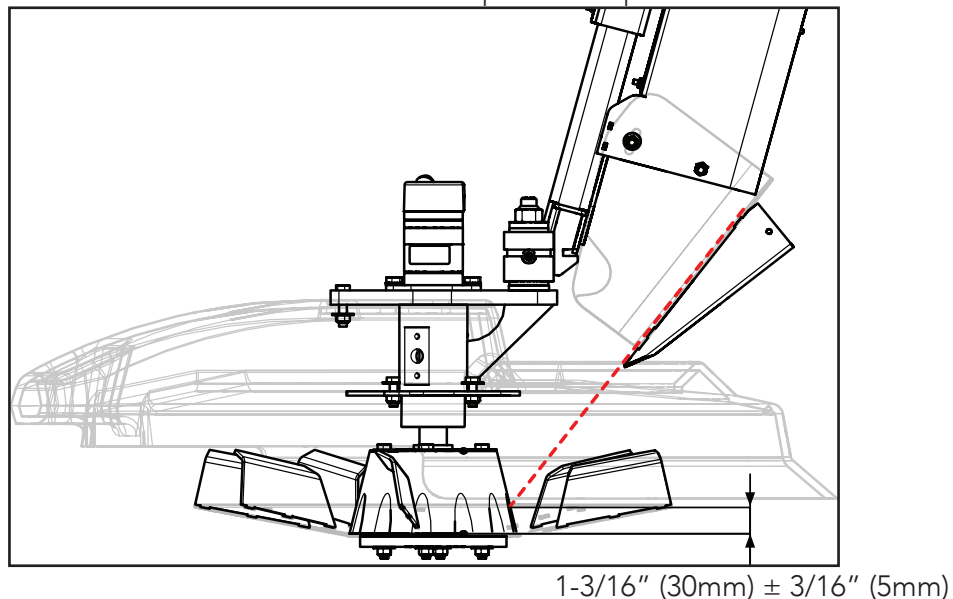

Figure 2 - Drop Point

4. Adjust as needed:
 - a. Loosen hardware on bottom of chute where chute meets the spinner hood.
 - b. Aim bottom part of chute at correct drop point.
 - c. Adjust to 1-3/16" (30mm) \pm 3/16" (5mm).
 - d. Tighten chute hardware.
 - e. Verify distance.

Setting Spinner Height

NOTICE Set spinner height when spreader is half full. Spinner height may be different between a full and empty load.

Spinner disc must be horizontal to ground when spreading. If disc is not horizontal to ground, spread pattern will be off. Adjust spinner as necessary.

1. Set spinner to Horizontal.
 - a. Figure 3 - Verify that clamp is tight (A).
 - b. Loosen spinner clamp hardware (B) two turns each.
 - c. Position disc horizontal to ground.
 - d. Verify that rubber stop on spinner pivot between mounting ears is holding spinner nearly horizontal or at a slight angle. Adjust as necessary.
 - e. Tighten spinner clamp hardware to proper torque.

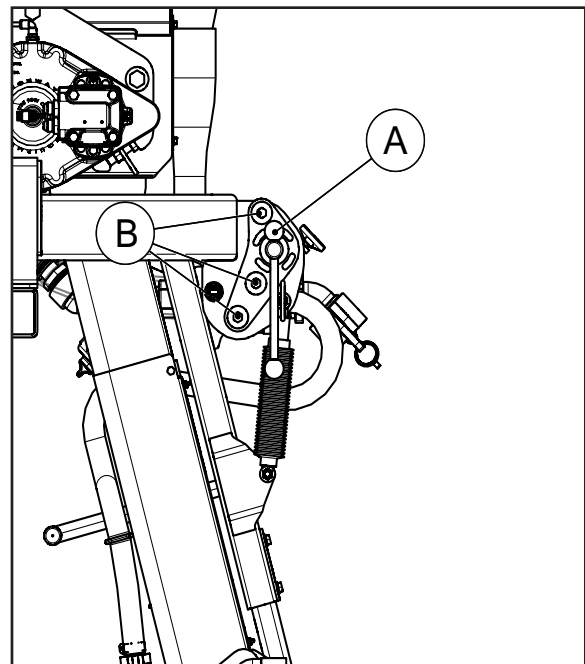

Figure 3

2. Adjust spinner height.
 - a. Figure 4 - Measure distance from outer edge of spinner disc to ground. Distance between disc and road surface must be $16'' \pm 2''$ (356-457mm). Note difference between required and actual height of disc.

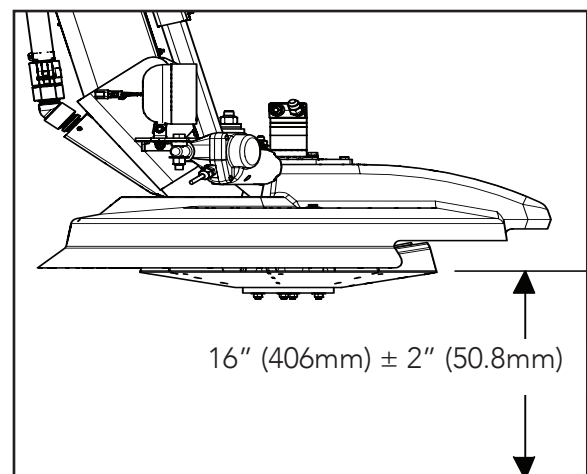

Figure 4

- b. Figure 5 - Loosen clamp and raise distribution system until horizontal to ground. Tighten clamp to hold position.
- c. Loosen hardware on chute lock plate (1) indicated in Figure 5.
- d. Move chute difference noted in step 2a. If disc is too high, move chute rearward. If too low, move forward.
For example: actual height of spinner disc is 13". Move chute forward three inches to achieve required spinner height.
- e. Tighten bolts.
- f. Lower chute to proper position and tighten clamp.
- g. Verify spinner height and repeat previous steps if necessary.

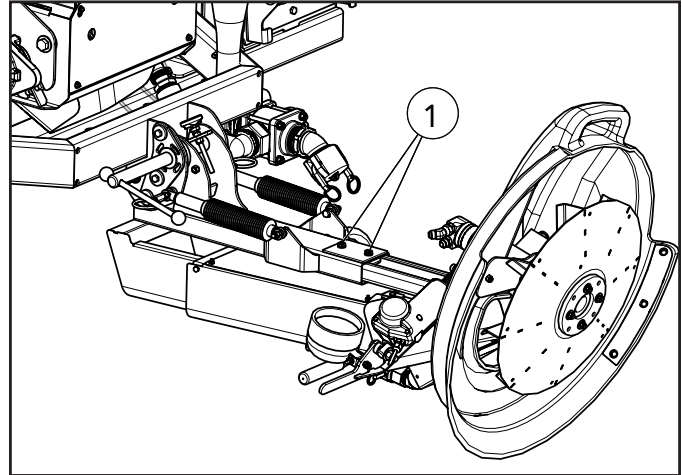

Figure 5

Filling Hopper

⚠ WARNING Stand clear of moving machinery and hopper when loading material to avoid injury or crushing. Failure to comply with this requirement could result in death or serious injury.

⚠ WARNING Load and unload spreader on a level firm surface. Failure to comply with this requirement could result in death or serious injury.

Tarp

Figure 1 - If equipped with a tarp, first pull the left-hand rope (A), then the right-hand rope (B) to open. Pull ropes in reverse order to close.

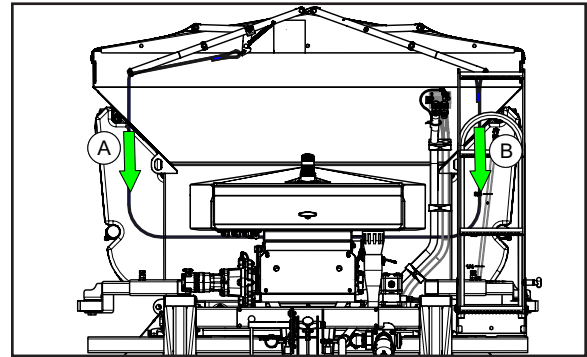

Figure 1

NOTICE Do not allow loading device to contact hopper. Doing so could cause damage.

Only use high quality, granular material for best performance.

Liquid System

The liquid system can be filled through tank caps or connection on rear of spreader.

Liquid Valve

To set liquid valve, turn handle to proper position as referenced below in Figure 2.

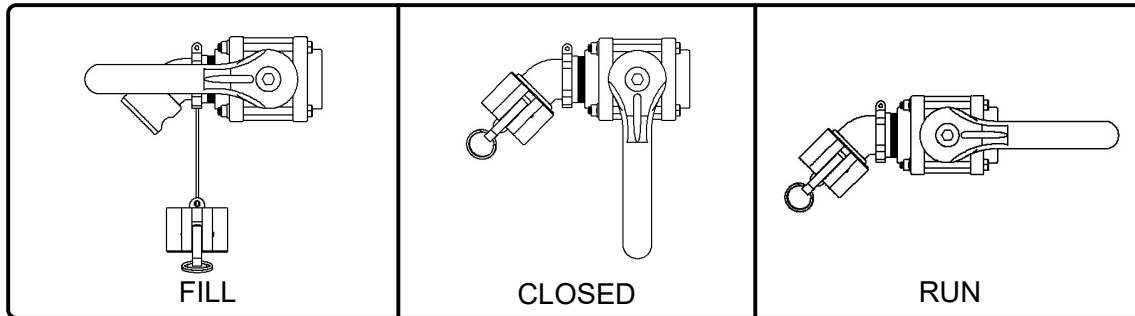

Figure 2A - Fill Position Figure 2B - Close Position Figure 2C - Run Position

NOTE: Close valve before connecting filling hose.

- Fill Position while filling the liquid tanks.
- Closed Position after spreading and during maintenance.
- Run Position while spreading.

Filling Liquid Tanks

CAUTION

Load spreader on truck before filling tanks. Liquid weight could collapse free-standing spreader, causing injury and damage to spreader. Failure to follow this requirement may result in injury or machine damage.

NOTICE

Valve must be in run position before operating liquid system or damage to pump may occur.

NOTICE

Refer to liquid tank capacity at beginning of manual before filling tanks.

Operations Continued

Valve Fill

1. Turn liquid valve to "Closed" position (Figure 2B).

2. Figure 3 - Unlock liquid valve cap and remove.

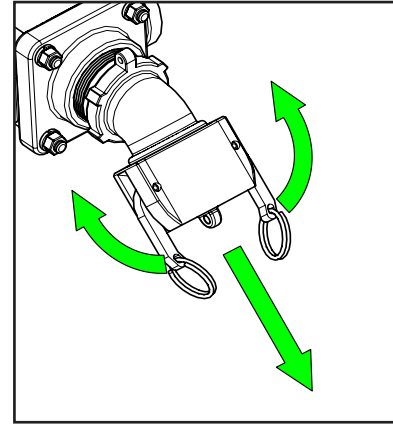

Figure 3 - Liquid Valve Cap

3. Attach filling hose to liquid valve.

4. Turn liquid valve to "Fill" position.

5. Figure 4 - Fill tanks to the desired amount indicated by sight gauge attached to rear of right tank.

6. Turn liquid valve to "Closed" position.

7. Remove filling hose from liquid valve.

8. Turn liquid valve to "Run" position.

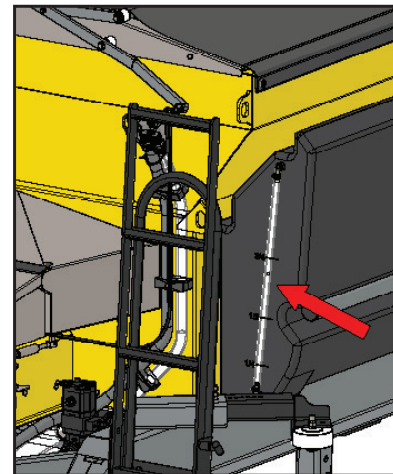

Figure 4 - Liquid Tank Gauge

Metering Gate

To set metering gate, move to proper position as referenced below.

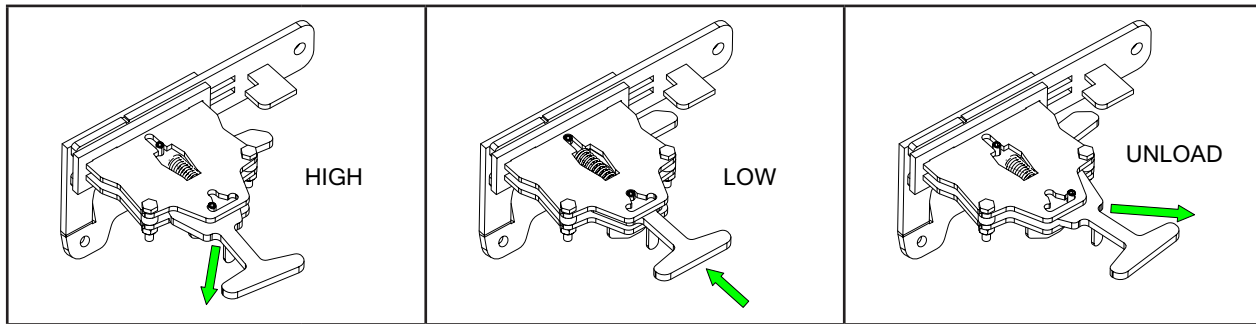

Figure 5

- High - 5-1/8" (130mm) Position for spreading material at high rates.
- Low - 1-9/16" (40mm) Standard position for spreading material at normal rates. Typical for materials like salt or salt/liquid.
- Unload Position for unloading bin after spreading. When no material is present, the metering gate will move downward automatically locking in the Low position.

Spreading Procedure

1. Set metering gate based on type of spreading material. See "Spread Rate Limits" .
2. Verify liquid valve is in "Run" position.
3. Turn on control box. Refer to control system's operation manual for instructions.

Manual Operation

⚠ WARNING

Flying material and rotating spinner can cause injury or death. Do not adjust spinner or valves when machine is running to avoid entanglement of hair or body parts, causing injury or death. Adjust valves with machine Off, then turn machine On and verify settings. Failure to comply with this requirement could result in death or serious injury.

The hydraulic valves in the control enclosure can be manually overridden to manually spread material if control system malfunctions. Only use this procedure as a last resort to unload or spread material. The hydraulic enable valve can be used to turn hydraulics on and off to spread manually.

To adjust valves:

1. Disconnect control cable at rear of truck.
2. Open rear enclosure to expose valves.
3. Figure 6 - Valve function is as follows:
 - A: Conveyor
 - B: Spinner
 - C: Liquid Pump
4. Figure 7 - Turn valve knob/stem (D) to adjust hydraulic flow to function - conveyor output, spinner RPM and liquid output.
 - Clockwise: Increase flow
 - Counter-clockwise: Decrease Flow
5. Adjust valves to visually achieve desired spread width and rates.
6. Close rear enclosure.

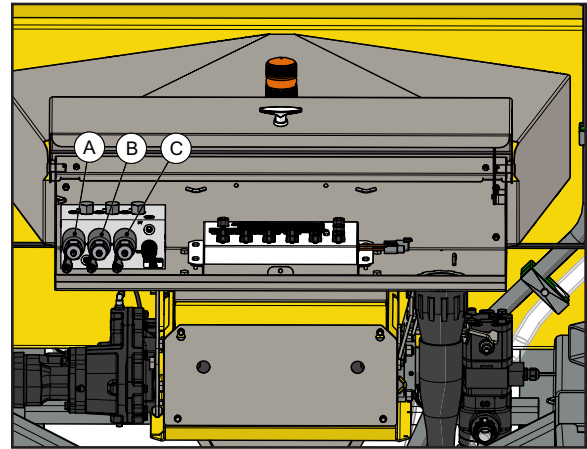

Figure 6

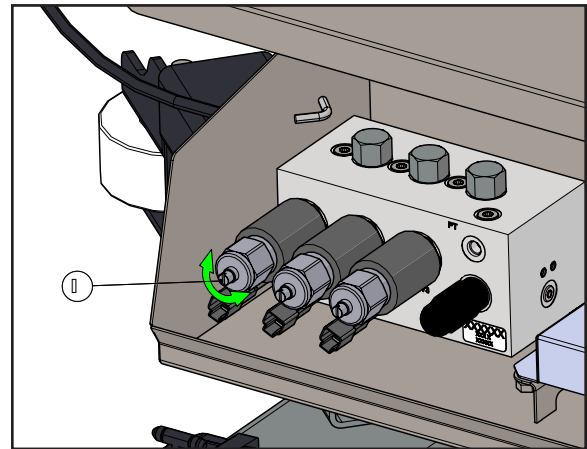

Figure 7

After repairing control system, return valves to original position.

Post-Spread

⚠ WARNING

Stand clear of moving machinery and hopper when loading or unloading material to avoid entanglement or being crushed, causing serious injury or death. Failure to comply with this requirement could result in death or serious injury.

⚠ WARNING

Load and unload spreader on a level, firm surface. Storing spreader on uneven or soft surface could cause spreader to tip causing death, serious injury or damage. Loading on soft surface could cause spreader to sink making removal difficult or causing damage. Failure to comply with this requirement could result in death or serious injury.

Emptying Hopper

1. Once at the desired location for unloading, lock spinner in upward position.
2. Set metering gate to "Unload" position.
3. Use controller "Unload" function to run conveyor.
4. Refer to control system's operation manual for instructions.

Emptying Liquid Tanks

Set liquid valve to "Fill" position. Tanks will empty by gravity drain.

NOTE: Controller liquid "Unload" function can be used to empty tanks. Refer to control system's operation manual for instructions.

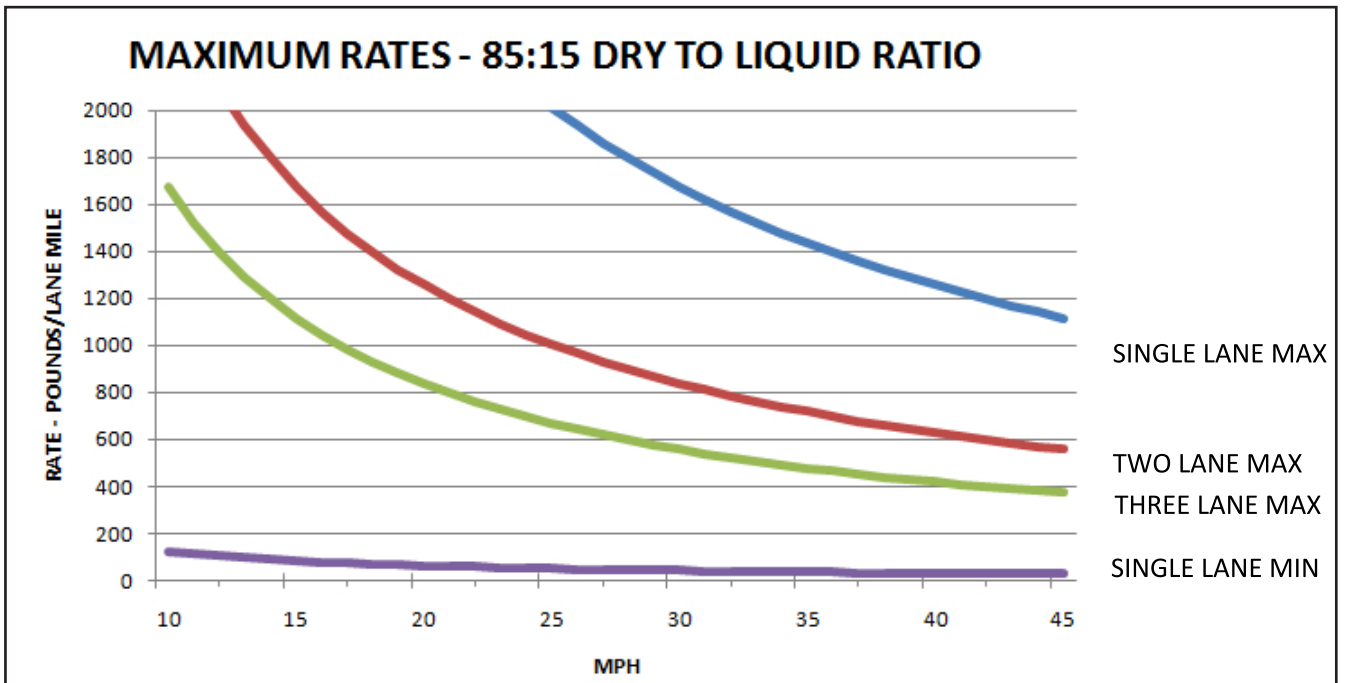
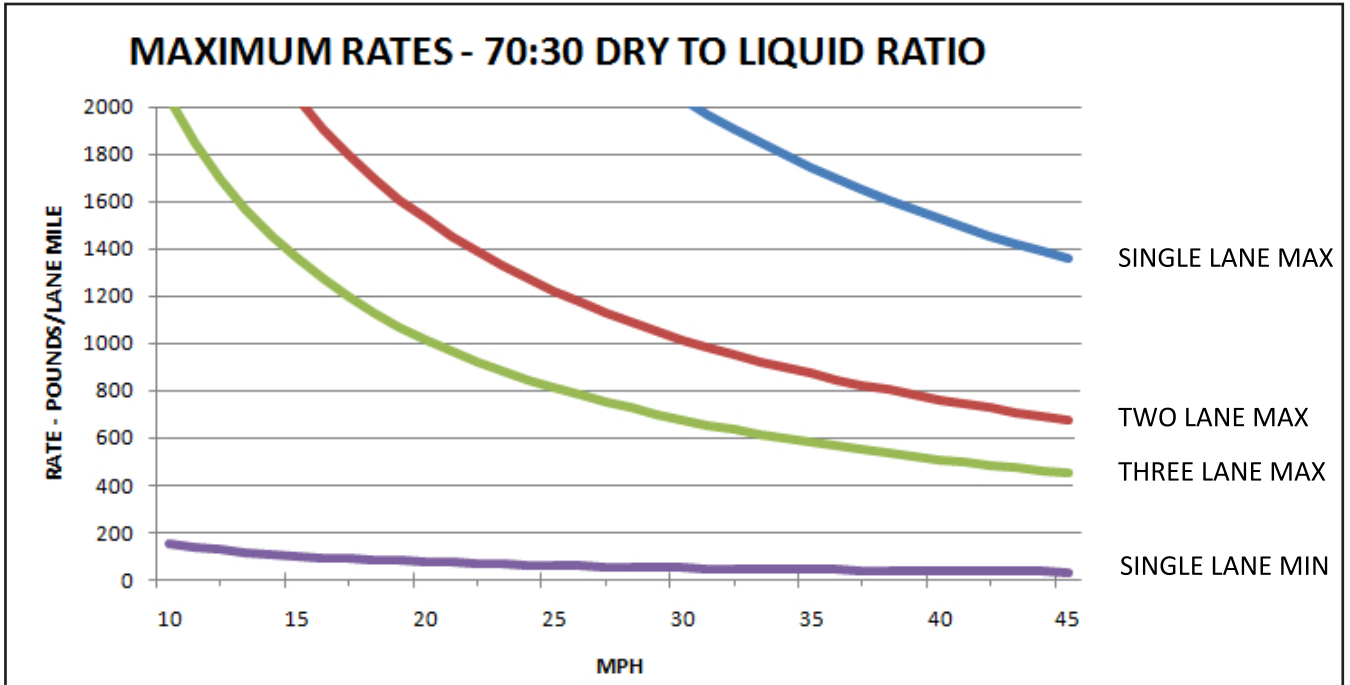

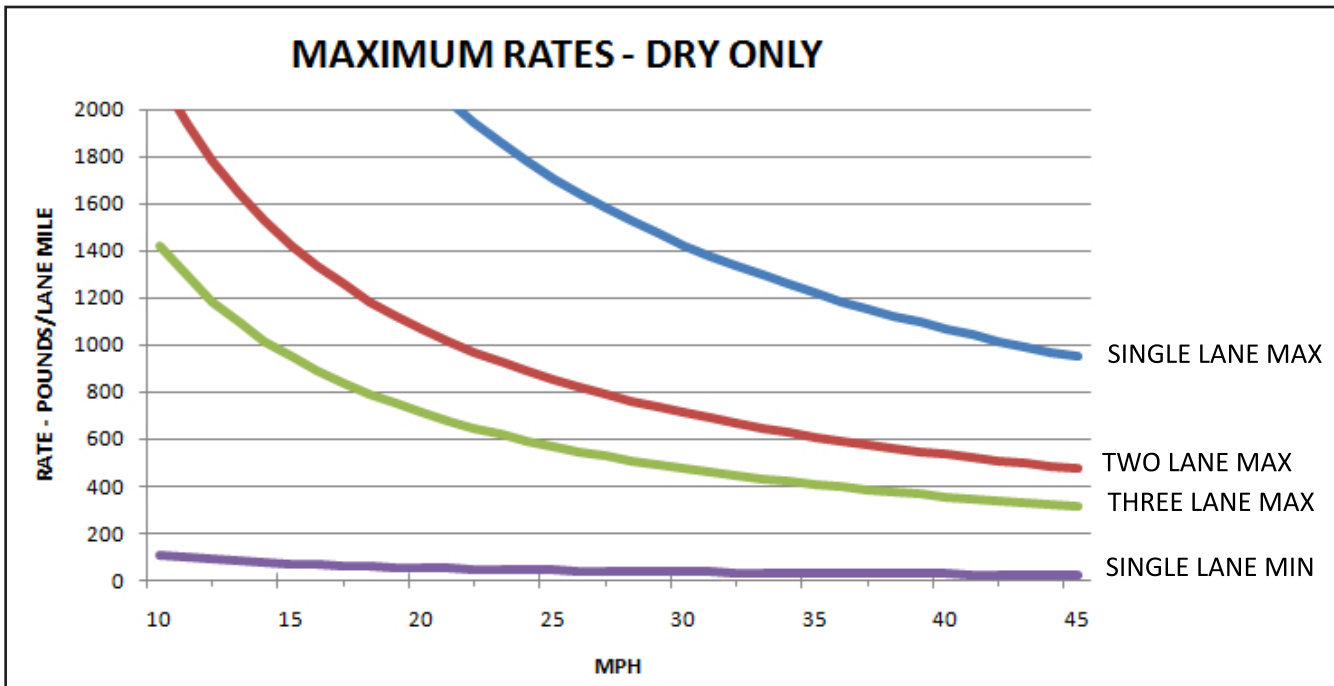

Typical Liquid Densities

LIQUID	DENSITY lbs/gal
Salt Brine	10.2
Calcium Chloride	10.92
Magnesium Chloride	10.53

NOTE: Liquids have specific gravity mixture. Consult product labels.

MAINTENANCE

Maintenance

Lubrication and Maintenance

Preventative Maintenance Pays!

The handling and spreading of commercial fertilizers is a most severe operation with respect to metal corrosion. Establish a frequent, periodic preventative maintenance program to prevent rapid deterioration to spreading equipment. Proper cleaning, lubrication and maintenance will yield longer life, more satisfactory service and more economical use of your equipment.

⚠ WARNING

Shut off all power and allow all moving parts to come to rest before performing any maintenance operation. Failure to comply with this requirement could result in death or serious injury.

Hydraulic System

Proper oil in the hydraulic system is one of the most important factors for satisfactory operation. Utmost cleanliness in handling the oil cannot be stressed enough. Keep hydraulic oil in original closed containers, clean top of container before opening and pouring, and handle in extremely clean measures and funnels.

Check hydraulic oil level and filter condition regularly.

Refer to "Lubricant and Hydraulic Oil Specifications" for selection of the proper hydraulic fluid for use in the hydraulic system.

⚠ WARNING

DO NOT check leaks with hands while system is operating as high pressure oil leaks can be dangerous! If skin is pierced with hydraulic fluid at high pressure seek immediate medical attention as fluid injected into the skin could cause gangrene if left untreated. Relieve pressure before disconnecting hydraulic lines or working system. Make sure all hydraulic fluid connections are tight and all hydraulic hoses and lines are in good condition before applying pressure to the system. Wear protective gloves and safety glasses or goggles when working with hydraulic systems. Failure to comply with this requirement could result in death or serious injury.

⚠ WARNING

DO NOT check for leaks adjacent to moving parts while system is operating as there may be danger of entanglement! Failure to comply with this requirement could result in death or serious injury.

Periodically inspect hydraulic hoses and fittings for leaks. Repair and replace components as necessary. Check hydraulic oil daily by means of sight gauge on hydraulic reservoir. Add oil as necessary to maintain level around mid-point of sight gauge. Periodically inspect hoses and fittings for leaks.

NOTICE

Change hydraulic oil filter after first week (or not more than 50 hours) of operation on a unit.

After first filter change, replace filter when indicator reaches Red Zone.

Drain reservoir through drain plug (not through suction outlet), flush, and refill and change filter element annually. Oil and filter should also be changed whenever oil shows any signs of breaking down under continued high-pressure operation. Discoloration of oil is one sign of breakdown.

Hydraulic Hose

Hose assemblies in operation should be inspected frequently for leakage, kinking, abrasion, corrosion or other signs of wear or damage. Worn or damaged hose assemblies should be replaced immediately.

▲ WARNING

Testing should be conducted in approved test stands with adequate guards to protect the operator. Failure to comply with this requirement could result in death or serious injury.

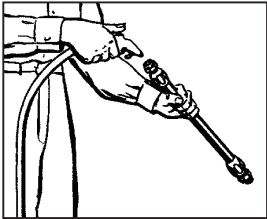

Clean

Clean assembly by blowing out with clean compressed air. Assemblies may be rinsed out with mineral spirits if the tube stock is compatible with oil, otherwise hot water at 150°F (65.55° C) maximum may be used.

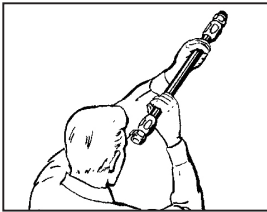

Inspect

Examine hose assembly internally for cut or bulged tube, obstructions, and cleanliness. For segment style fittings, be sure that the hose butts up against the nipple shoulder; band and retaining ring are properly set and tight, and segments are properly spaced. Check for proper gap between nut and socket or hex and socket. Nuts should swivel freely. Check the layline of the hose to be sure the assembly is not twisted. Cap the ends of the hose with plastic covers to keep clean.

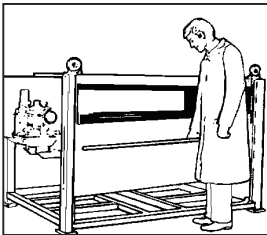

Test

The hose assembly should be hydrostatically tested at twice the recommended working pressure of the hose.

Test pressure should be held for not more than one minute and not less than 30 seconds. When test pressure is reached, visually inspect hose assembly for: 1. Any leaks or signs of weakness. 2. Any movement of the hose fitting in relation to the hose. Any of these defects are cause for rejection.

Storage and Handling

Hose should be stored in a dark, dry atmosphere away from electrical equipment, and the temperature should not exceed 90° F (32° C).

Lubrication & Maintenance Continued

Electrical System

NOTICE Refer to control system's operation manual for correct battery voltage for spreader and conveyor. Incorrect voltage can cause damage to the control box and/or spreader's electronics.

NOTICE DO NOT weld on spreader while power supply is connected to spreader and control box. Damage could occur to the electric system.

Periodically check electrical connections and cables for wear or damage. Disconnected plugs must always be protected from corrosion; cap all unused plugs with a sealed end. Before reconnecting components, remove any corrosion from connectors and lubricate with electrical contact spray.

Liquid System

NOTICE Ensure liquid system is filled with salt solution or other agent at all times to prevent freezing.

Liquid Pump

The liquid pump must always be "primed" to avoid corrosion of internal components. If the pump is left dry, liquid will not be delivered initially when conveyor is activated. Flush the liquid system with non-corrosive agent if system is idle for 5-10 days to avoid crystallization of chemicals in pump. Flush pump with hot water should crystallization occur.

See "Filling the Liquid Tanks" in Operations section for filling instructions.

Suction Strainer

Clean the suction strainer with water weekly or after every major event.

Figure 1 - Turn liquid valve to the "Closed" position and unscrew cap behind liquid valve. Remove strainer and rinse with water until clean, replace as necessary. Replace strainer and screw cap on tight.

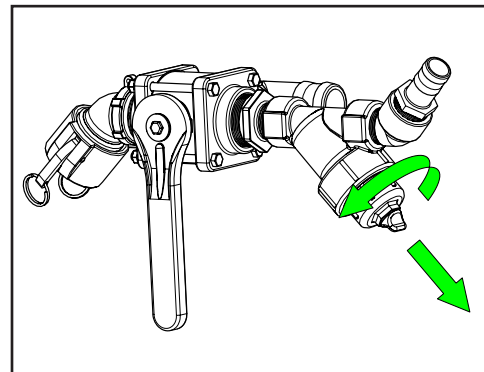

Figure 1

At the end of the season, thoroughly flush and clean the liquid system with hot soapy water.

Belt Conveyor

⚠ WARNING

Stay out of the spreader. If it's necessary to enter the spreader, return to the shop, empty body, turn off all power, set vehicle brakes, lock engine starting switch and remove keys before entering. Tag all controls to prohibit operation. Tags should be placed, and later removed, only by person working in the body. Failure to comply with this requirement could result in death or serious injury.

Tension

Figure 2 - Check torque of adjustment bolts (A) on each side of idler roller at front of spreader. Tighten bolts to 29 ft-lbs (40 N-m).

NOTE: For new belts, it may be necessary to re-tension conveyor after 24 hours.

NOTE: It is not necessary to release conveyor tension after spreading or for storage.

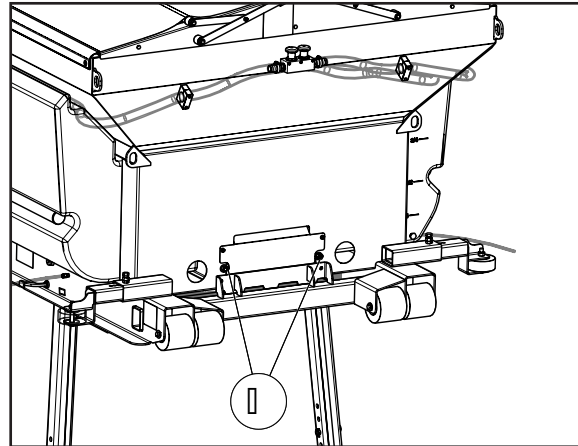

Figure 2

Tracking

1. With spreader hopper empty, use controller "Unload" function to run conveyor belt at low speed.
2. Remove conveyor cover at front of spreader.
3. At slow speed, observe the tracking of the belt.
4. Figure 3 - Adjust the belt by tightening the adjustment bolt on the side that the belt wanders towards:
 - Belt runs towards left: Tighten the left adjustment bolt.
 - Belt runs towards right: Tighten the right adjustment bolt.

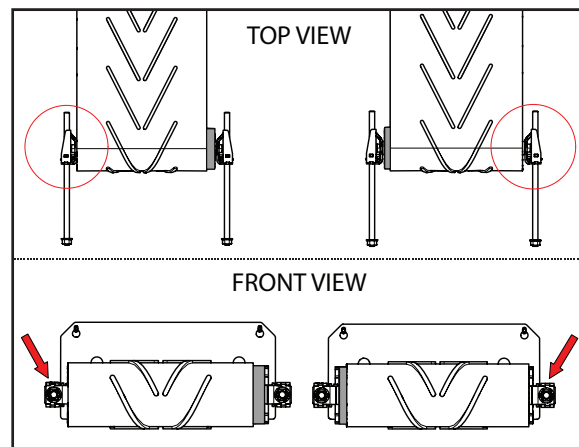

Figure 3

Lubrication & Maintenance Continued

Wiper Brushes

Regularly check the wiper brushes at the rear of the conveyor for wear and tear. Bristles must brush across the entire width of the conveyor belt without bending severely. Brushes must be replaced if they are worn or not performing properly.

Adjustment/Replacement

1. Figure 4 - Loosen brush hardware (A).
2. Remove worn brush and replace as necessary.
3. With hardware loose, position brush so edge contacts full width of conveyor belt.
4. Tighten hardware to proper torque.

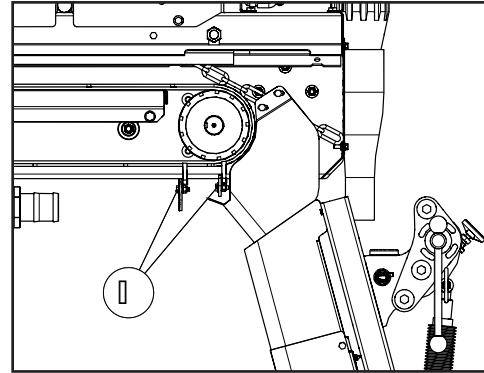

Figure 4

Cleaning Under Conveyor

With conveyor shut off, periodically inspect for material build up at the front of the machine near tensioning roller.

Conveyor Gearcase

Drain oil in a new unit after first two weeks (or not more than 100 hours) of operation, and flush gear case thoroughly with light oil. Refer to "Lubricant and Hydraulic Oil Specifications" section for proper grade oil and recommended amounts of lubricant. After initial change, oil should be changed every 2,000 hours of operation or annually, whichever occurs first.

Check gearcase oil level monthly.

Sensors

Figure 5 - The XZALT utilizes four sensors for metering gate and spinner function:

- Spinner Speed (A)
- Spinner Down (B)
- Low Gate (C)
- Dry Out (D)

These sensors are installed and set at the factory. However, resetting will be required if related parts are replaced, or if control issues occur. To adjust, follow instructions below.

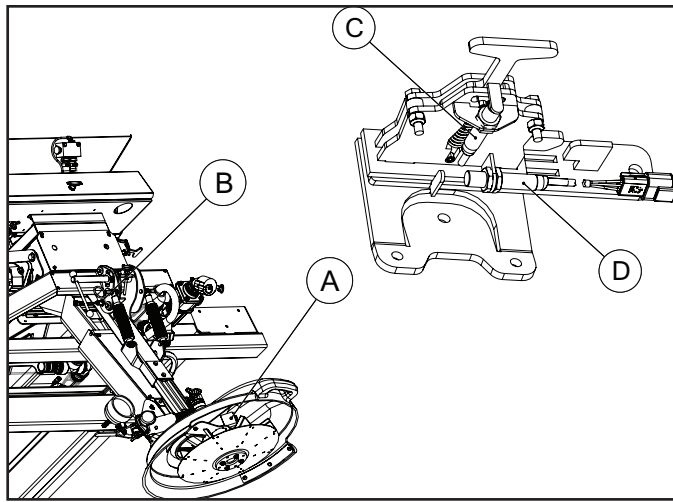

Figure 5

Spinner Speed Sensor

1. Remove spinner speed sensor assembly from spinner shaft.
2. Loosen set screw (A) to adjust spinner speed sensor.
3. Spinner speed sensor should protrude from mounting block (B) 0.630" (16mm).
4. Once sensor is properly set, tighten set screw.

NOTICE Sensor must NOT come in contact with spinner shaft. Damage will occur if sensor contacts shaft.

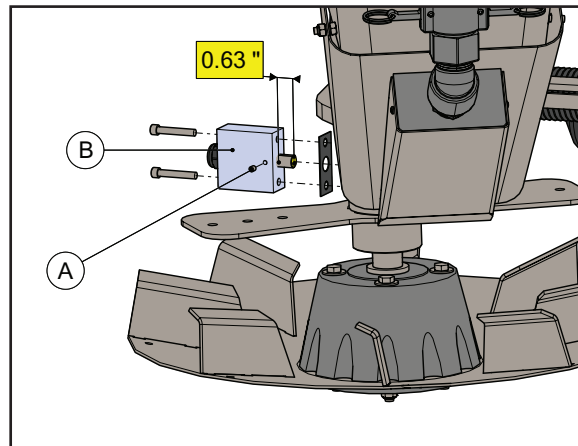

Figure 6

Lubrication & Maintenance Continued

Spinner Up Sensor

1. Loosen sensor lock nuts.
2. Adjust sensor to obtain a 0.157" (4mm) gap between end of sensor and spinner assembly.
3. Once sensor is properly set, tighten lock nuts.

NOTICE

Sensor must NOT come in contact with spinner assembly. Damage will occur if sensor contacts mechanism.

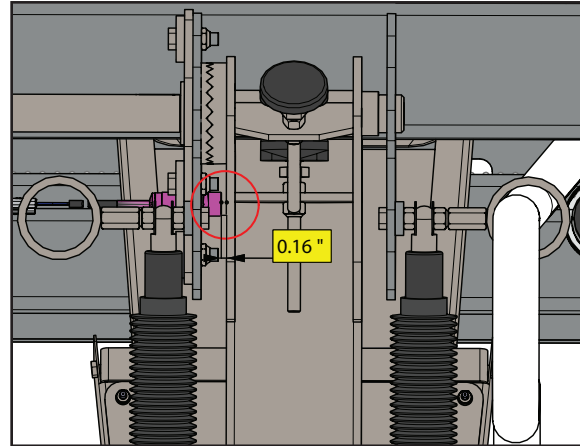

Figure 7

Low Gate Sensor

1. Lock adjustment handle in "Low" position.
2. Loosen sensor lock nuts (A)
3. Adjust sensor to obtain a 0.055" (1.4mm) gap between end of sensor and tab on handle.
4. Once sensor is properly set, tighten lock nuts.

NOTICE

Sensor must NOT come in contact with spinner assembly. Damage will occur if sensor contacts mechanism.

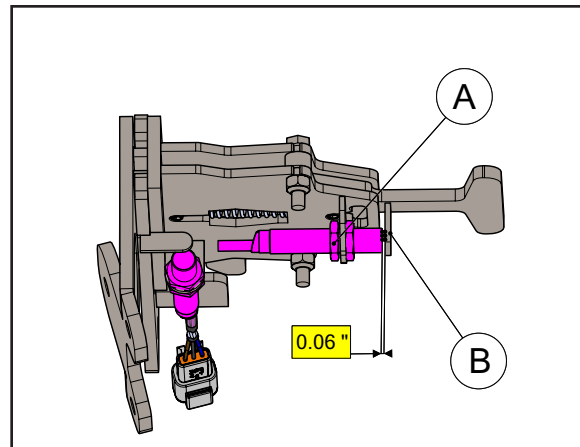

Figure 8

Dry Out Sensor

1. Lock Adjustment handle in "Unload" position.
2. Loosen Sensor Lock nuts.
3. Adjust sensor to obtain a 0.055" (1.4mm) gap between end of sensor and tab on slider bolt of feedgate mechanism.
4. Once sensor is properly set, tighten lock nuts.

Lubrication of Bearings

Grease in a bearing acts to prevent excessive wear of parts, protects ball races, and balls from corrosion and aids in preventing excessive heat within the bearing. It is very important the grease maintain its proper consistency during operation. It must not be fluid and it must not channel.

Make sure all fittings are thoroughly cleaned before grease is injected. Points to be lubricated by means of a grease gun have standard grease fittings.

Lubricate bearings by pumping grease slowly until it forms a slight bead around the seals. This bead indicates adequate lubrication and also provides additional protection against the entrance of dirt.

Fasteners

Tighten all screws fasteners to recommended torques after first week of operation and annually thereafter. If loose fasteners are found at anytime, tighten to recommended torque. Replace any lost or damaged fasteners or other parts immediately. Check body mounting hardware every week.

Clean-Up

NOTICE High pressure wash can inject water and/or fertilizer into control components, causing damage. Use caution when cleaning these areas.

Thoroughly wash unit every two to three days during the operating season to maintain minimal maintenance operation. Hose unit down under pressure to free all sticky and frozen material.

It is important the unit be thoroughly cleaned at the end of each operating season. All lubrication and maintenance instructions should be closely followed. Repaint worn spots to prevent formation of rust.

MULTIBIN Meter Wheel(s): Pull inspection plug on right hand side of micro assembly. Blow out with compressed air.

Hydraulic System

Use premium quality lubricants with 100-200 SUS or 20-43 cSt viscosity at operating temperatures. The hydraulic fluid's specifications in the table below are for normal operating conditions. Extreme environments or dirty conditions may require the use of different oils. Consult your New Leader dealer or the Product Support Department at Highway Equipment Company for systems operating outside normal conditions.

Ideal Oil Operating Temperature	115-158°F (46.11-70° C)
Recommended Premium Lubricant	Multi-Purpose Agriculture Hydraulic & Transmission Oil
Lubricant Specifications Viscosity Index Viscosity at 40°C, cst Viscosity at 100°C, cst	Greater than 130 Less than 68 Greater than 9
Acceptable Fluid Example	Mobil 424

Gearcase Lubricant

Lubricate these assemblies with non-corrosive type extreme pressure (E.P.) gear oil conforming to MIL-L2105 B multi-purpose gear lubricating oil requirements (API Service GL 4) based on ambient temperatures listed below. Refill gear case with one and a half (1-1/2) pints (.70 liters) of recommended lubricant.

Ambient Temperature	Below 40° (4.44°C)	Between 40° (4.44°C) and 100° (37.77°C)	Above 100° (37.77°C)
Oil Type	SAE 80 E.P.	SAE 90 E.P.	SAE 140 E.P.

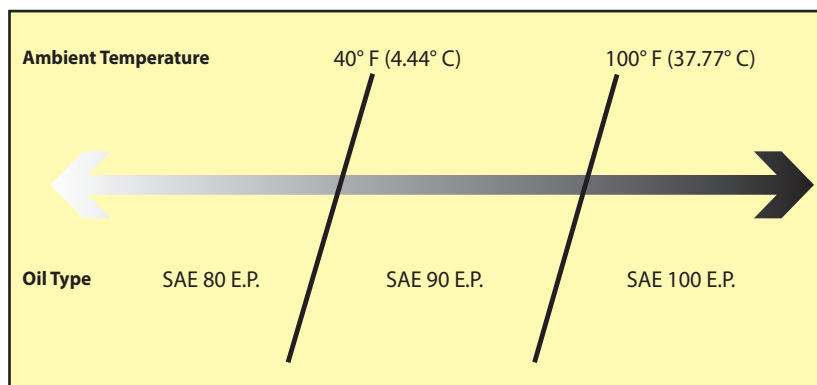

Grease Gun Lubricant

Use a waterproof ball and roller bearing lithium base lubricant with a minimum melting point of 300°F (148.8° C). This lubricant should have a viscosity which assures easy handling in the pressure gun at prevailing atmospheric temperatures. The grease should conform to NLGI No. 2 consistency.



Lubrication & Maintenance Chart

⚠ WARNING Shut off all power and allow all moving parts to come to rest before performing any maintenance operation. Failure to comply with this requirement could result in death or serious injury.

The spreader should be regularly lubricated with the lubricants recommended in this manual in accordance with the following chart:

Location	Places	Method	Frequency
Transmission PTO			
Slip Yoke	1	Grease Gun	Weekly
Universal Joint	2	Grease Gun	Monthly
Hydraulic System			
Reservoir	1		Check Daily. Change Annually
Filter	1	Check daily; Change when indicated (Red)	
Conveyor			
Grease Zerks - Drive Shaft Bearings (A)	2	Grease Gun	Weekly
Gearcase	1	Gear Oil	Check Monthly; Change Annually
Spinner			
Spinner Assembly/Chute Pivot Shaft (B)	1	Grease Gun	Weekly
Grease Zerks - Jack (C)	1	Grease Gun	Weekly
Subframe			
Front Support Leg Pivot (D) (Dump Body Mount Only)	2	Grease Gun	Weekly

NOTE: Unusual conditions, such as excessive dust, temperature extremes or excessive moisture may require more frequent lubrication of specific parts.

*See "Lubricant and Hydraulic Oil Specifications" for types of lubricants and oil to be used.



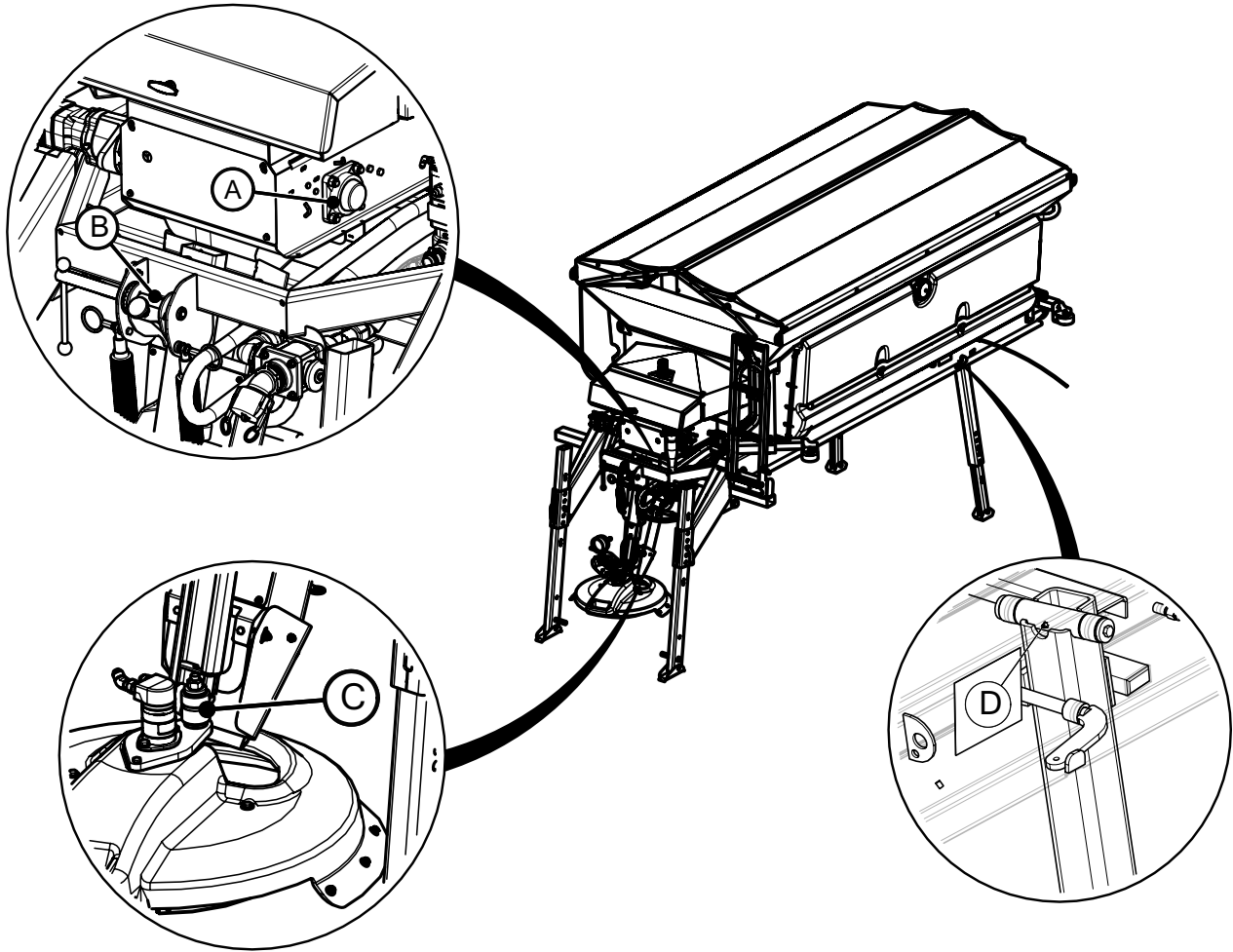

CAP SCREW GRADE IDENTIFICATION - MARKINGS ON HEAD

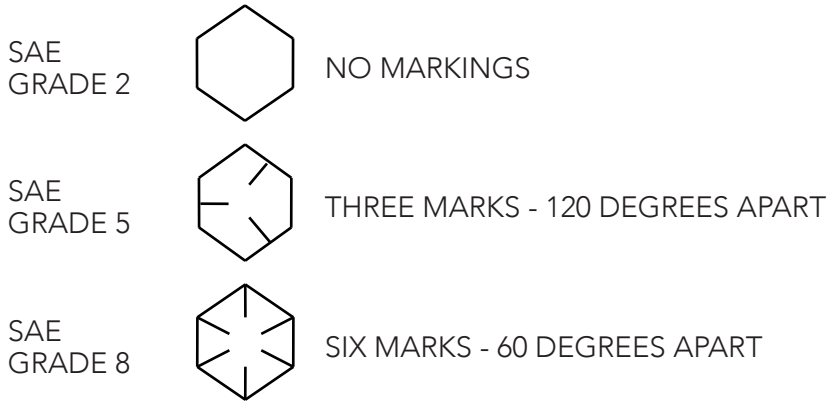

USE GRADE 2 TORQUES FOR STAINLESS STEEL FASTENERS AND CARRIAGE BOLTS.

CAP SCREW SIZE	TORQUE - FOOT-POUNDS					
	GRADE 2		GRADE 5		GRADE 8	
	DRY	LUBE	DRY	LUBE	DRY	LUBE
1/4"	5	4	8	6	12	9
5/16"	11	8	17	13	25	18
3/8"	20	15	30	23	45	35
7/16"	30	24	50	35	70	55
1/2"	50	35	75	55	110	80
9/16"	65	50	110	80	150	110
5/8"	90	70	150	110	220	170
3/4"	100	120	260	200	380	280
7/8"	140	110	400	300	600	460
1"	220	160	580	440	900	650

Troubleshooting

The following pages contain representative schematics and diagnostic aids for the XZALT model spreader.

COMMON CAUSES FOR FAILURE			
MECHANICAL	ELECTRICAL	HYDRAULIC	CONTROLLER
<ul style="list-style-type: none"> • Siezed Components • Sheared Key • Conveyor Slippage • Fill Valve Position • Plugged Strainer • Metering Gate Malfunction 	<ul style="list-style-type: none"> • Power • Ground • Blown Fuse • Faulty Valve Solenoid • MMM <ul style="list-style-type: none"> • CAN Power • CAN Communication • Connections • Harnessing 	<ul style="list-style-type: none"> • Pump <ul style="list-style-type: none"> • Flow • Pressure • RPM • Oil Level • Relief • Enable • Load Sense 	<ul style="list-style-type: none"> • Settings



Sensor Troubleshooting

Chute Down Sensor

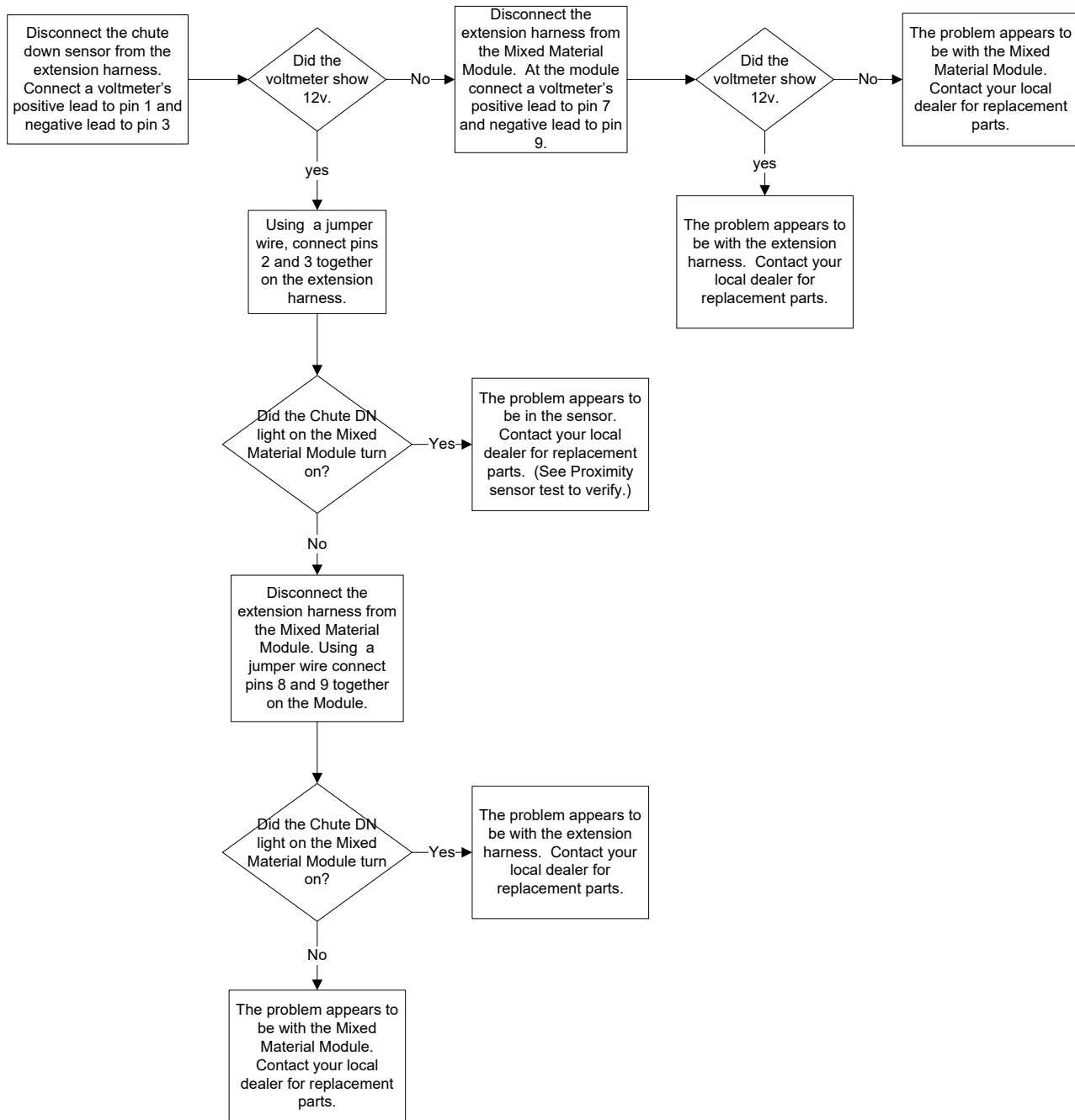

Liquid Speed Sensor

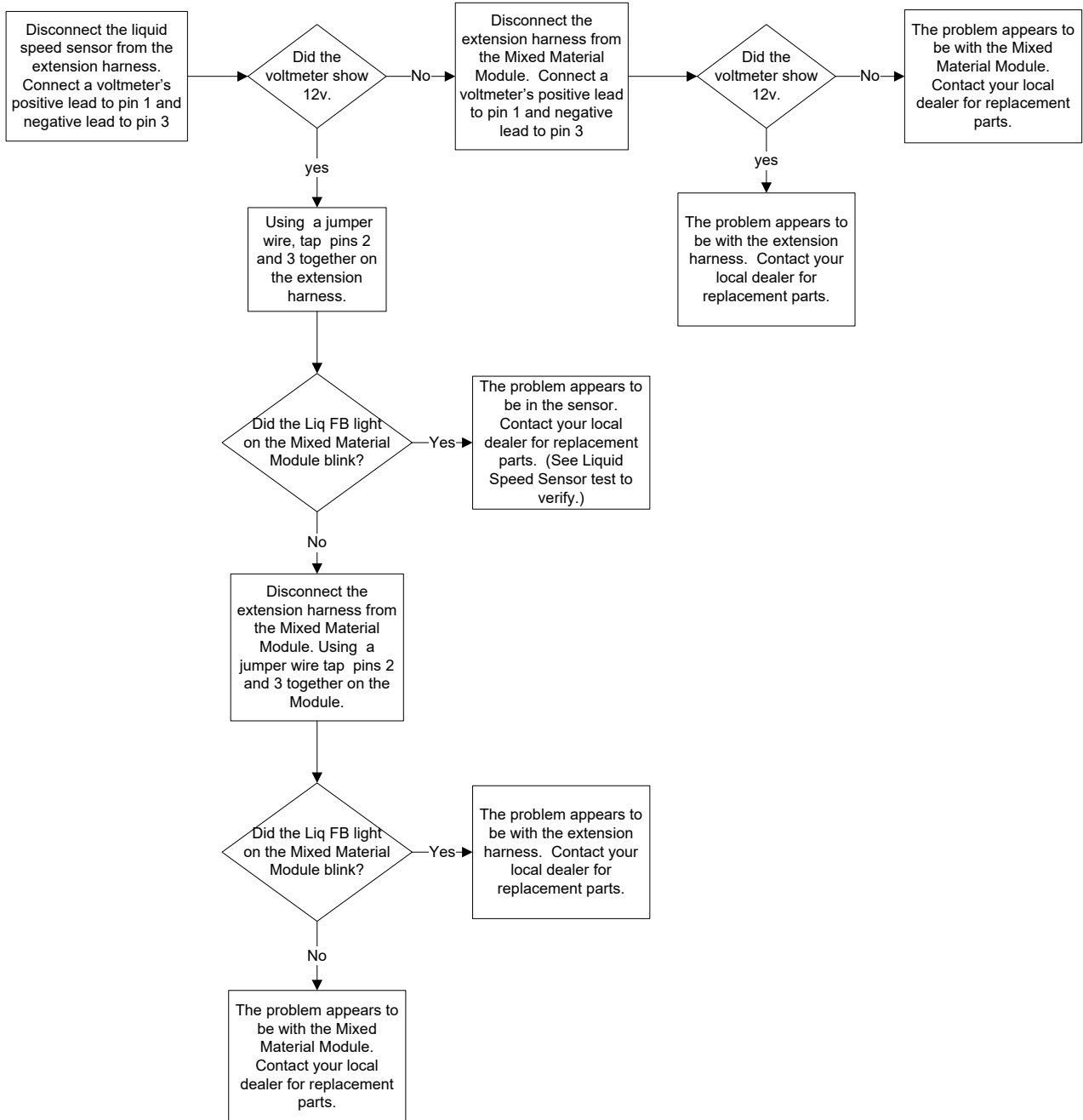

Troubleshooting Continued

Spinner Speed Sensor

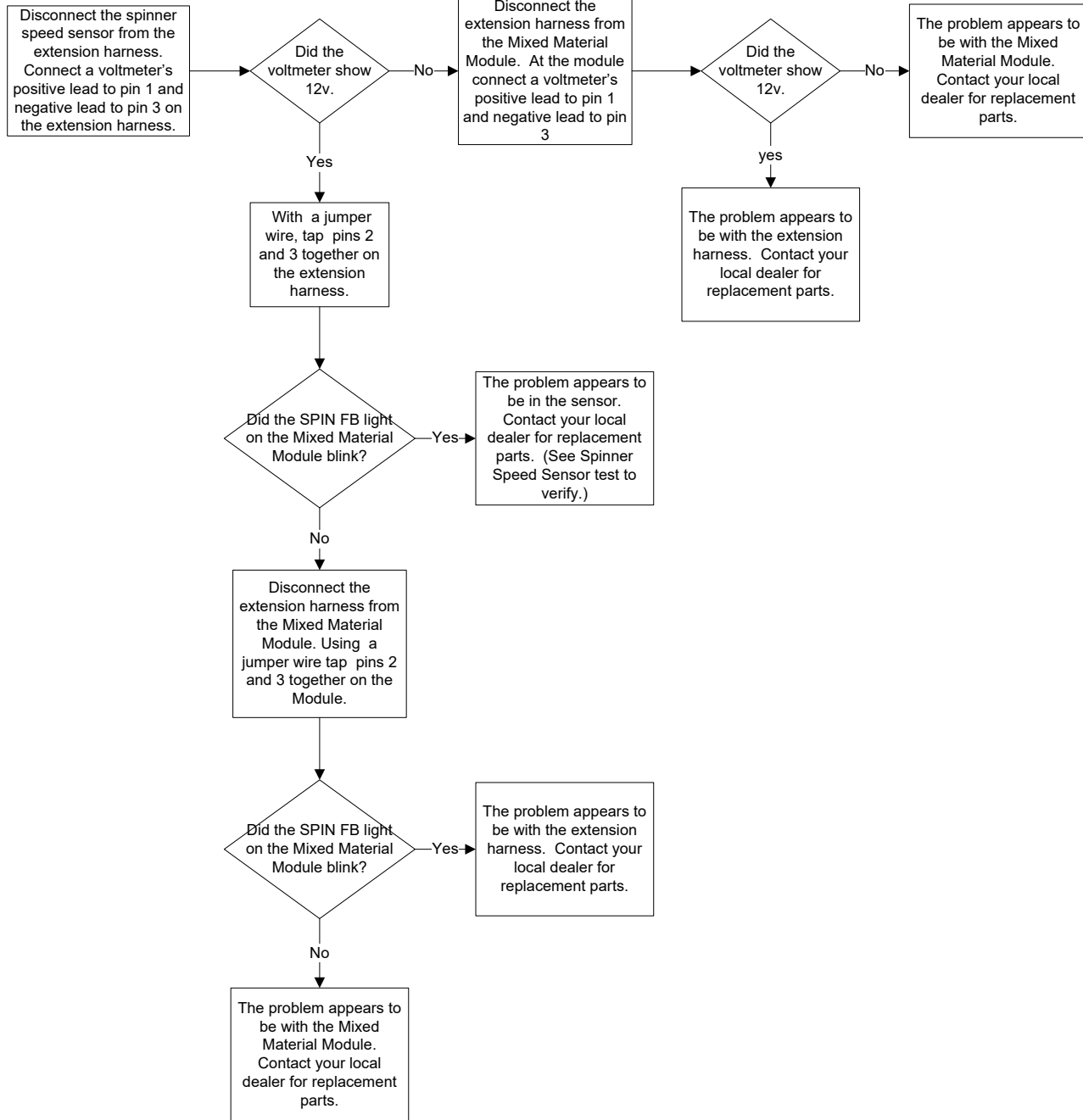

Test Procedure

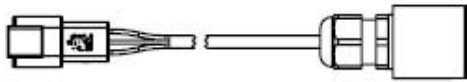

LIQUID SPEED
SENSOR



GATE LOW
SENSOR



CHUTE DOWN
SESNOR

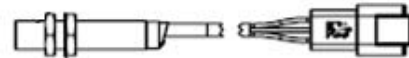

DRY OUT
SENSOR

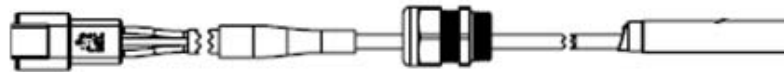

SPINNER SPEED
SENSOR

Pin	Color	Function
1	Blue	12 volt
2	Black	Signal
3	Brown	Ground

Test Procedures

1. Connect a 12v power supply to the sensor with the positive to pin 1 and the negative to pin 3.
2. Connect voltmeter's positive lead to pin 1 and connect voltmeter's negative lead to pin 2.
3. Pass a metallic object over the sensor once this is done voltmeter should measure 12 volts. When the metal object is removed the voltmeter should measure 0 volts. If this does not happen, the sensor is defective.

Note: The sensor LED should be lit when a piece of steel is passed over the sensor.

Low Liquid Sensor

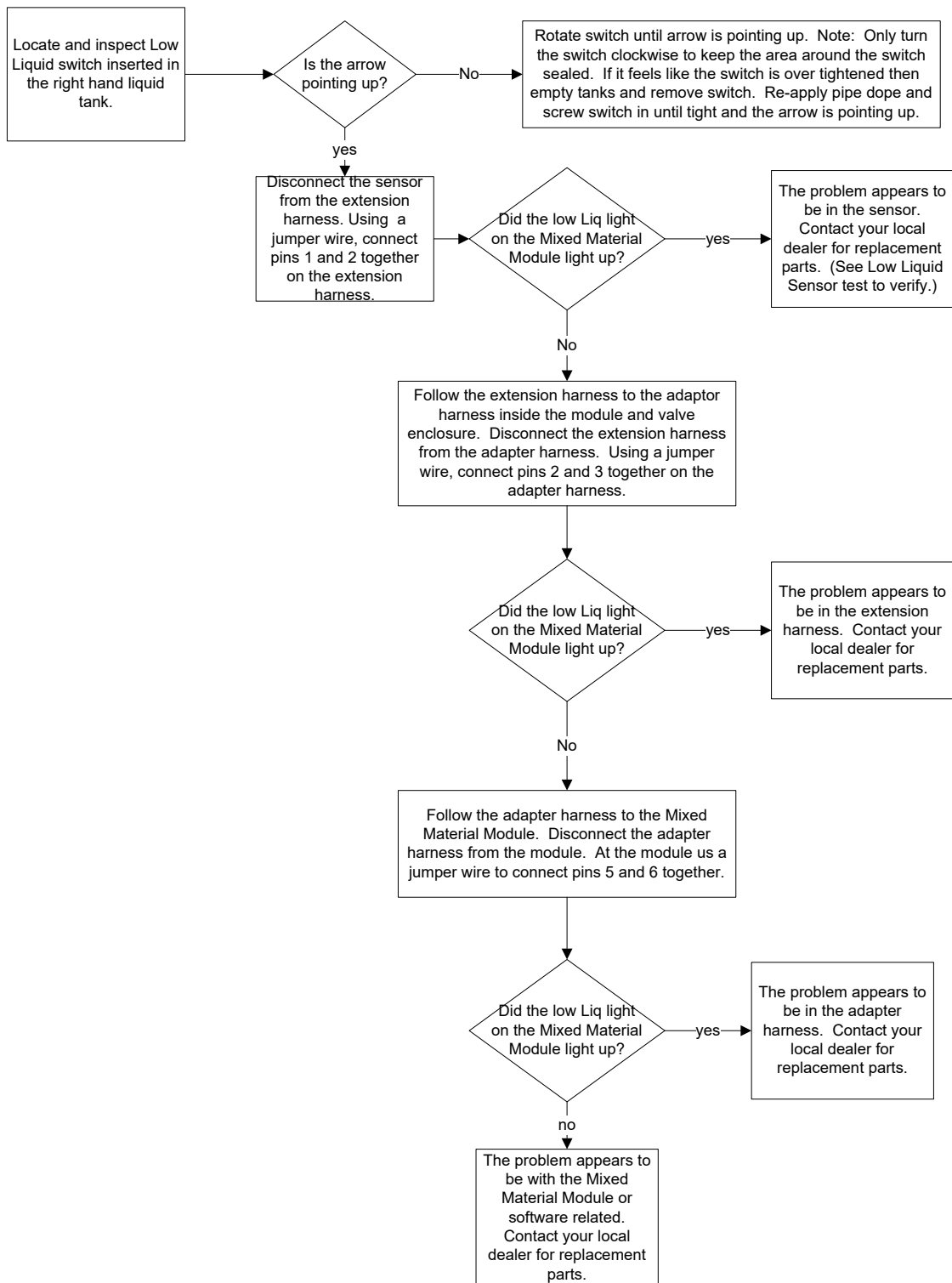

Test Procedure



FLOAT SWITCH

With the arrow pointing up, connect an ohm meter's positive lead to pin 1 and the negative lead to pin 2.

With the float down the circuit should be open.
With the float up the circuit should be closed.

Conveyor Speed Sensor



CONVEYOR SPEED
SENSOR



Pin	Color	Function
A	Brown	12 volt
B	Blue	Ground
C	Black	Signal

Test Procedures

1. Remove sensor from motor sensor housing adapter.
2. Connect a 12v power supply to the sensor with positive to pin A and the negative to pin B.
2. Connect voltmeter's positive lead to pin A connect voltmeter's negative lead to pin C.
3. The voltmeter will read 0v or 12v. Pass a magnet over the sensor and observe the voltmeter for a change to either 0 or 12v. Example. If the original voltage reading was 12v, the voltage reading should change to 0v once the magnet passes over the sensor. If this does not happen, the sensor is defective.

Controller Operations

Not Functioning in Closed Loop

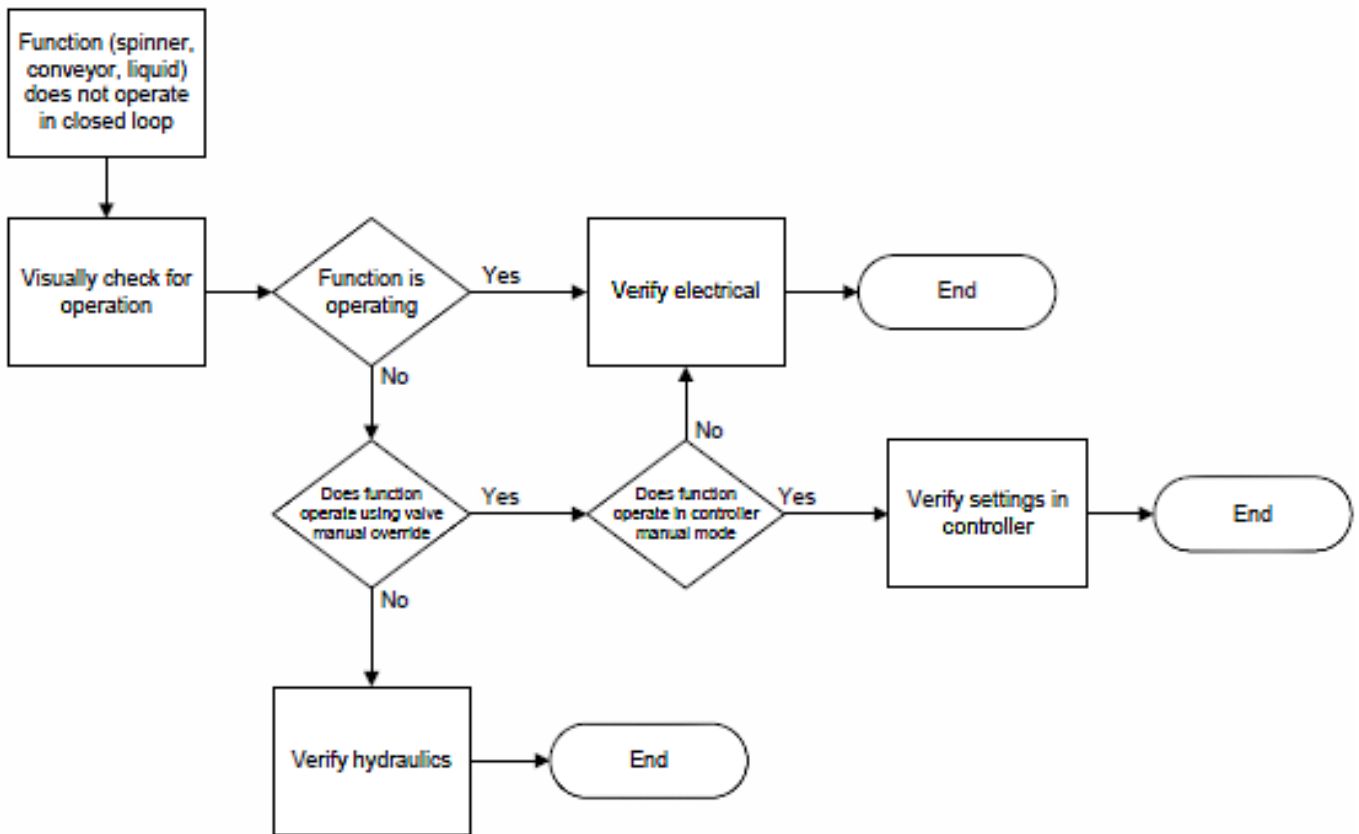

Spinner Does Not Move

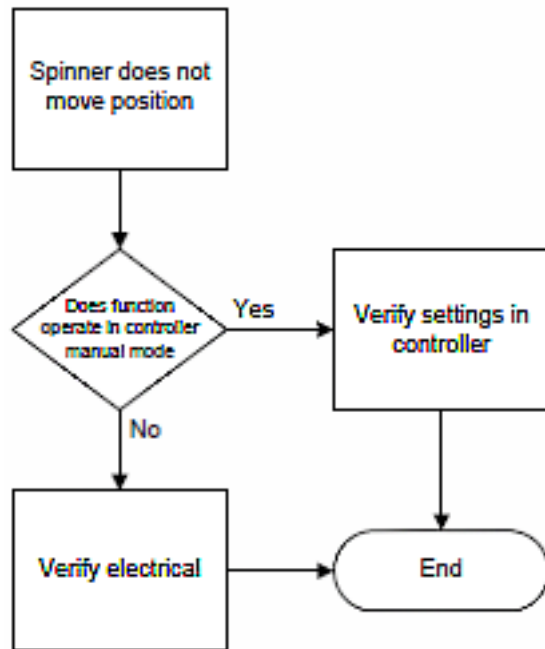

Troubleshooting Continued

Function Does Not Achieve Desired Rate

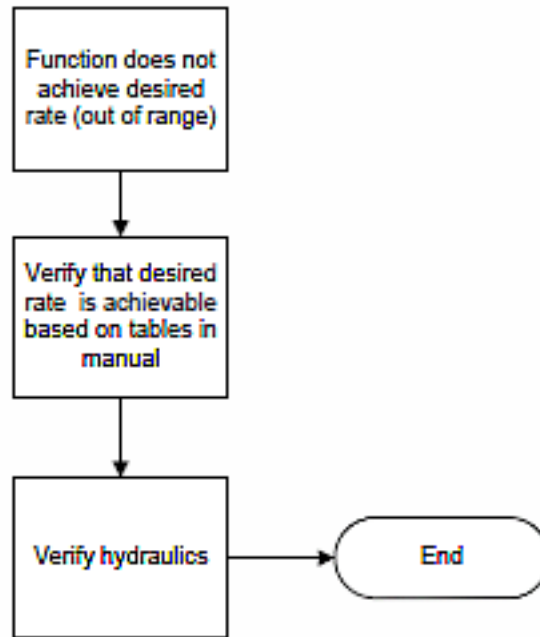

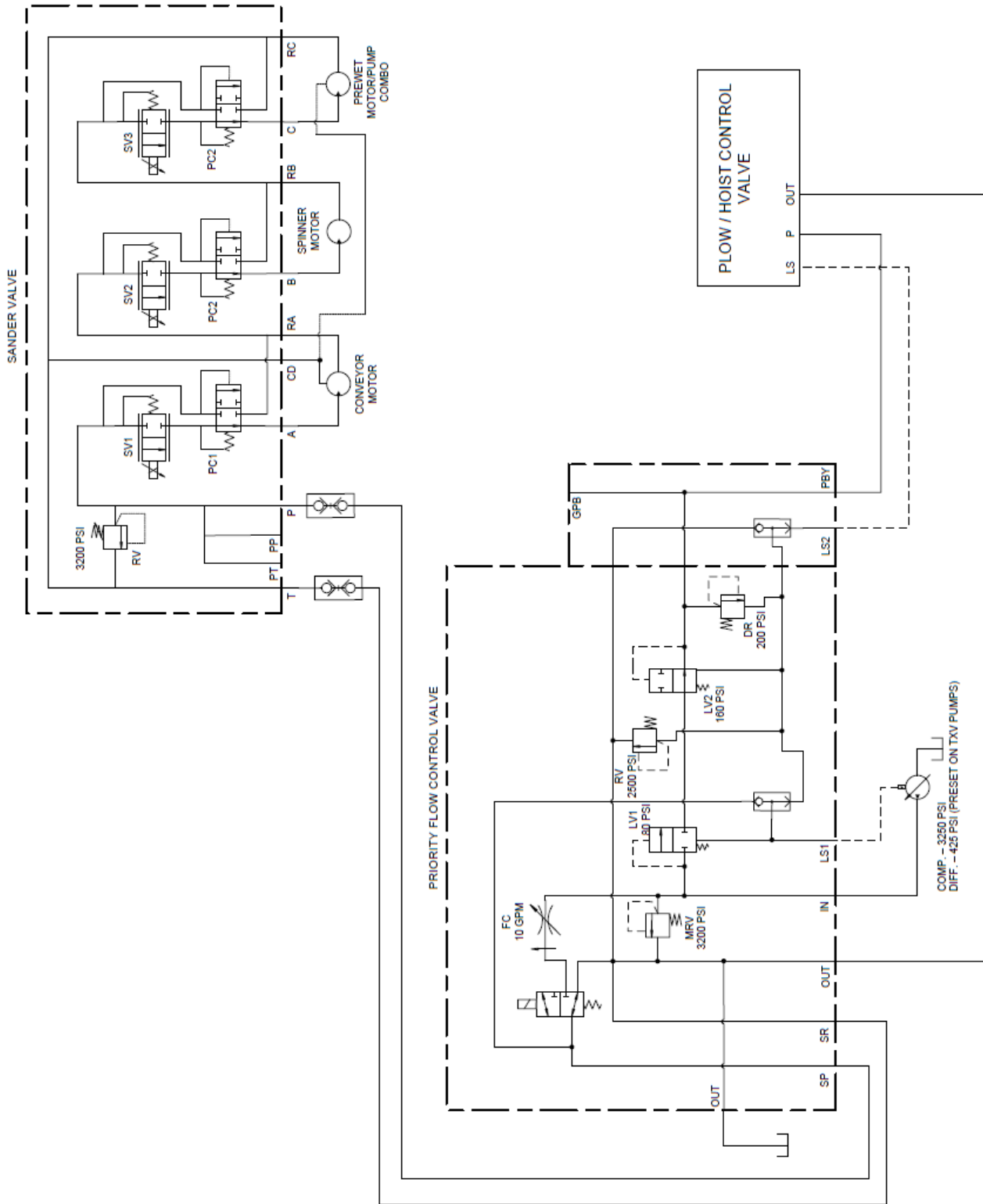

PARTS

Instructions for Ordering Parts



Order from the **AUTHORIZED DEALER** in your area.

1. Always give the pertinent model and serial number.
2. Give part name, part number and the quantity required.
3. Give the correct address to where the parts are to be shipped, and the carrier if there is a preference.

Unless claims for shortages or errors are made immediately upon receipt of goods they will not be considered. Any part returns should be directed through the dealer from which they were purchased.

When broken goods are received, a full description of the damage should be made by the carrier agent on the freight bill. If this description is insisted upon, full damage can always be collected from the transportation company.

No responsibility is assumed for delay or damage to merchandise while in transit. Our responsibility ceases upon delivery of shipment to the transportation company from whom a receipt is received showing that shipment was in good condition when delivered to them, therefore, claims (if any) should be filed with the transportation company and not with New Leader Manufacturing.

If your claims are not being handled (by the transportation company) to your satisfaction, please call our Product Sales & Support Department at New Leader Manufacturing at 888-363-8006 for assistance.

In the parts list the following symbols and abbreviations stand for:

* - Not Shown
 AR – As Required
 CS – Carbon Steel
 SS – Stainless Steel
 NS – Not Serviced

The parts listed under the different steel types (CS and 304 SS) are for that type of unit and do not necessarily mean the part is made of that type of steel.



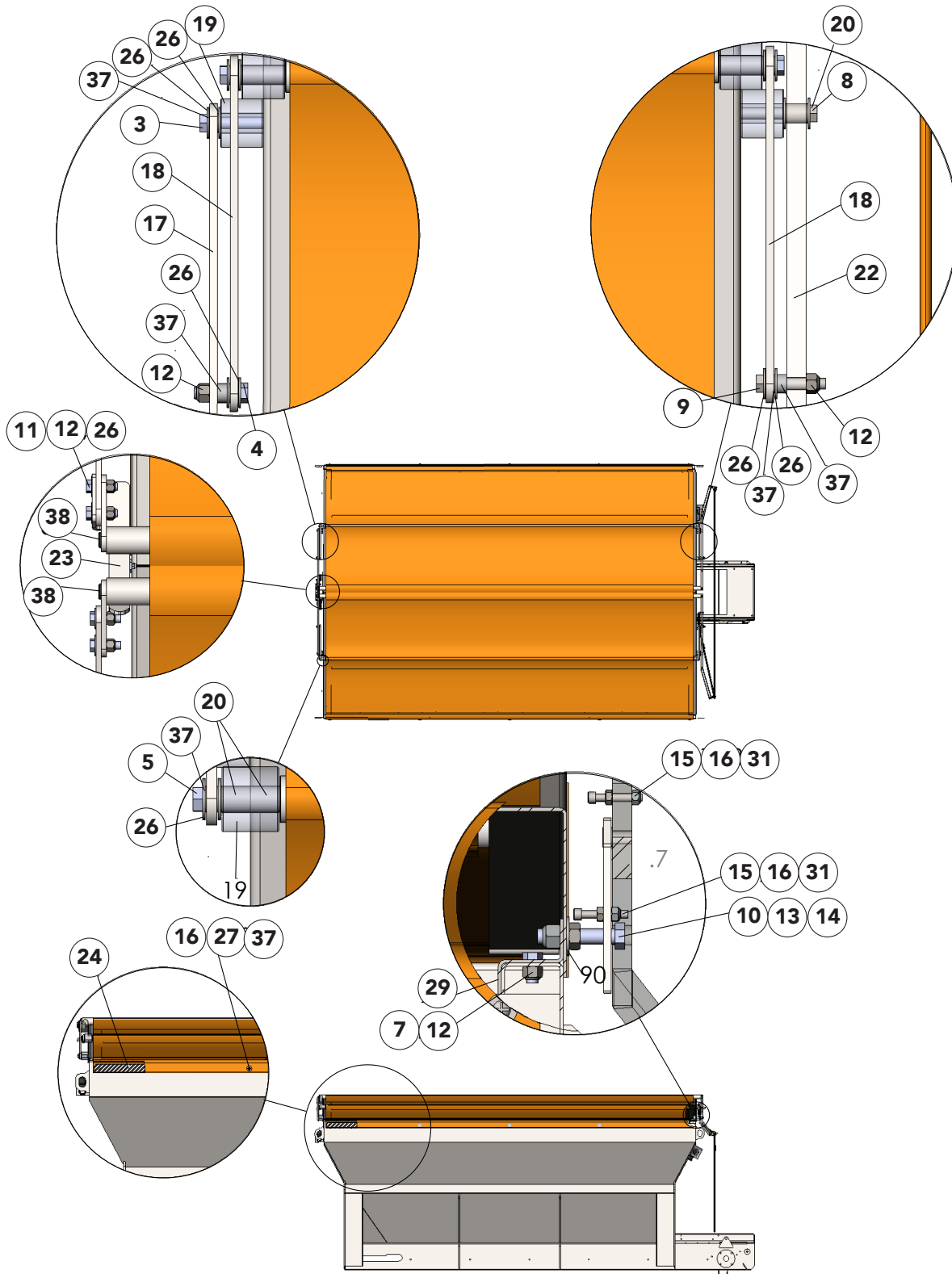

Tarp Continued

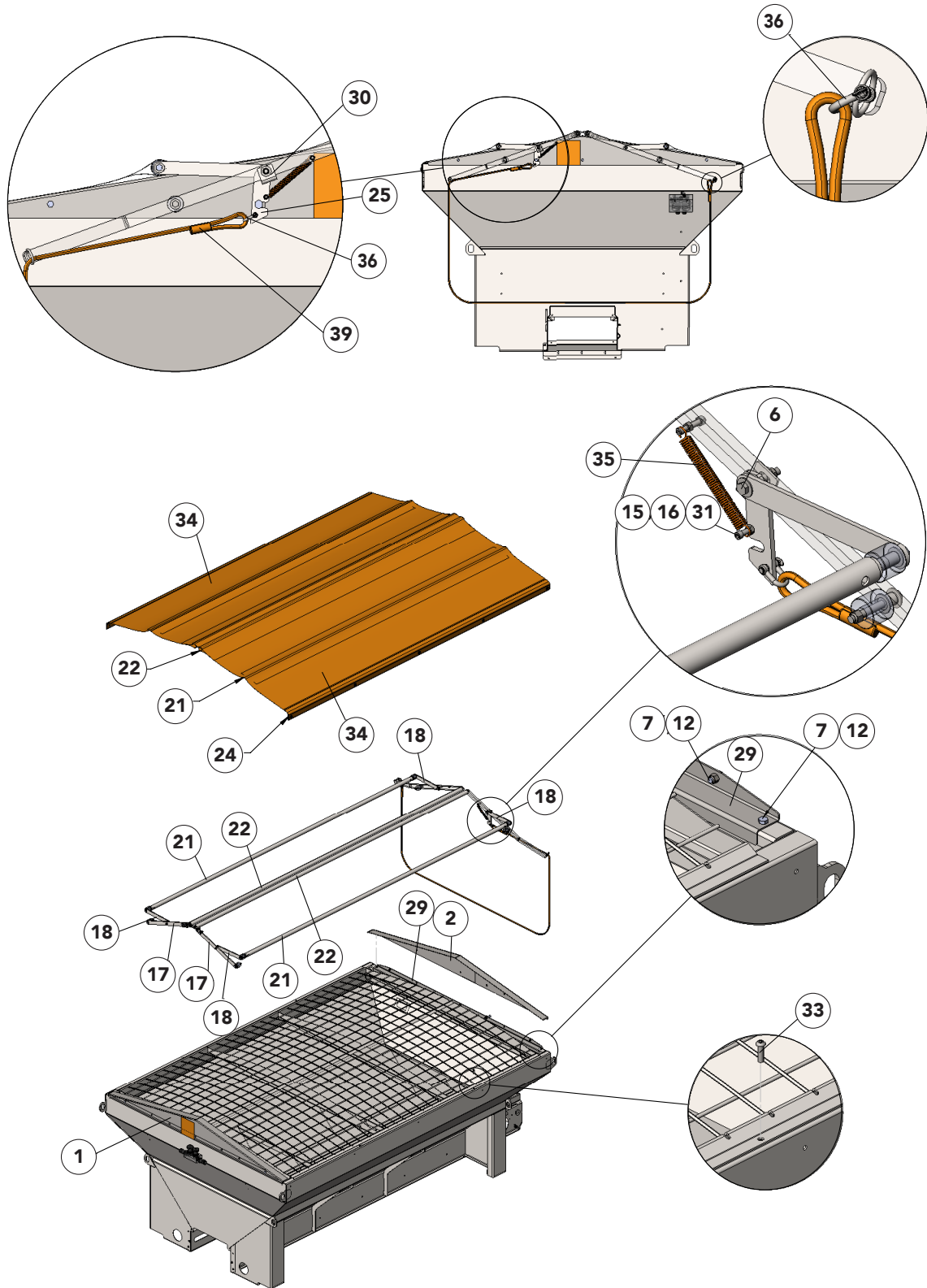

Tarp Continued

<u>ITEM</u>	<u>PART NO.</u>	<u>DESCRIPTION</u>	<u>QTY</u>
1	308407	Plate- Wldmt Tarp End Front 304	1
2	308408	Plate- Wldmt Tarp End Rear 304	1
3	36296	Cap Screw- .38-16NC x 2-3/4 SS	2
4	34858	Cap Screw- 3/8-16NC x 1-1/2 SS	2
5	36400	Cap Screw- 3/8-16NC x 2-1/2 SS	4
6	71828	Cap Screw- 3/8-16NC x 2-1/4 SS	1
7	36293	Cap Screw- 3/8-16NC x 3/4 SS	14
8	71827	Cap Screw- 3/8-16NC x 3 SS	2
9	34859	Cap Screw- 3/8-16NC x 2 SS	1
10	42454	Cap Screw- 1/2-13NC x 2-1/2 SS	1
11	36399	Cap Screw- 3/8-16NC x 1-1/4 SS	4
12	72054	Nut- Lock 3/8-16NC SS	26
13	36416	Nut- Hex 1/2-13NC SS	1
14	39016	Nut- Lock 1/2-13NC SS	1
15	42034	Nut- Lock 1/4-20NC SS	2
16	36412	Nut- Hex 1/4-20NC SS	12
17	309504	Linkage- Tarp Long Galvanized	2
18	309505	Linkage- Tarp Short Galvanized	4
19	308398	Roller- Tarp	8
20	308401	Spacer 304	10
21	309501	Pipe- Tarp Outer 10' Galvanized	2
	309502	Pipe- Tarp Outer 12' Galvanized	2
	305903	Pipe- Tarp Outer 14' Galvanized	2
22	309498	Pipe- Tarp Inner 10' Galvanized	2
	309499	Pipe- Tarp Inner 12' Galvanized	2
	309500	Pipe- Tarp Inner 14' Galvanized	2
23	309506	Lock- Tarp Front Galvanized	1
24	309508	Flat- Anchor Tarp 10' Galvanized	2
	305909	Flat- Anchor Tarp 12' Galvanized	2
	305910	Flat- Anchor Tarp 14' Galvanized	2
25	309507	Lock- Tarp Rear Galvanized	1
26	36425	Washer- Flat 3/8 SS	29
27	21423-X1	Washer- Flat 1/4 Special SS	10
28	36426	Washer- Flat 1/2 SS	1
29	308404	Angle- Mounting Plate End 304	2
30	309497	Stop- Lock Galvanized	1
31	308047	Screw- Sockethead 1/4-20NC x 1-1/2 SS	2
32	42033	Screw- Truss Head 1/4-20NC x 1 SS	10



Tarp Continued

<u>ITEM</u>	<u>PART NO.</u>	<u>DESCRIPTION</u>	<u>QTY</u>
33	71772	Screw- Buttonhead 3/8-16NC x 1-1/4 SS	2
34	308409	Tarp- 10'	2
	308373	Tarp- 12'	2
	308422	Tarp- 14'	2
35	308411	Spring- SS	1
36	308412	D-Shackle- SS	2
37	88050	Spacer	14
38	308406	Plug- Plastic 3/4	4
39	308400	Rope- Tarp	1



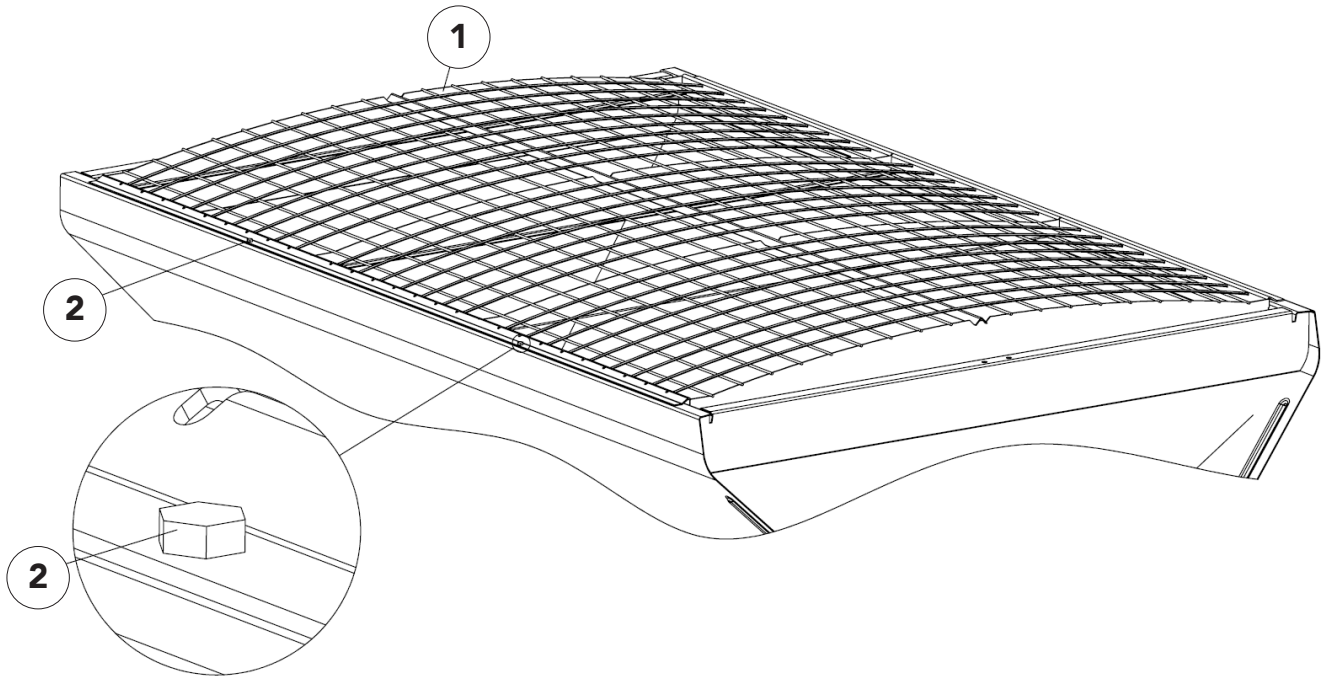

<u>ITEM</u>	<u>PART NO.</u>	<u>DESCRIPTION</u>	<u>QTY</u>
1	308228	Screen- 10' x 82" Galvanized	1
	308324	Screen- 12' x 82" Galvanized	1
	308325	Screen- 12' x 82" Galvanized	1
2	36293	Cap Screw- .375-16NC x .75 SS	AR

AR- As Required

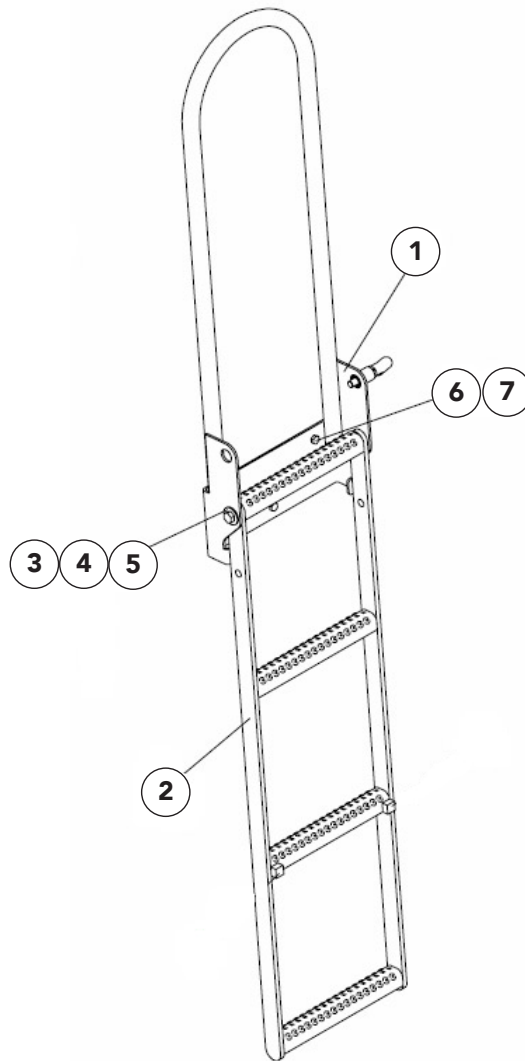

<u>ITEM</u>	<u>PART NO.</u>	<u>DESCRIPTION</u>	<u>QTY</u>
1	308153	Mount- Wldmt Ladder Inspection	1
2	308157	Ladder- Wldmt Inspection	1
3	20695	Washer- Flat .5	2
4	20129	Cap Screw- .5-13NC x 1.5	2
5	20680	Nut- Lock .5-13NC	2
6	20067	Cap Screw- .375-16NC x 1	3
7	20678	Nut- Lock .375-16NC	3

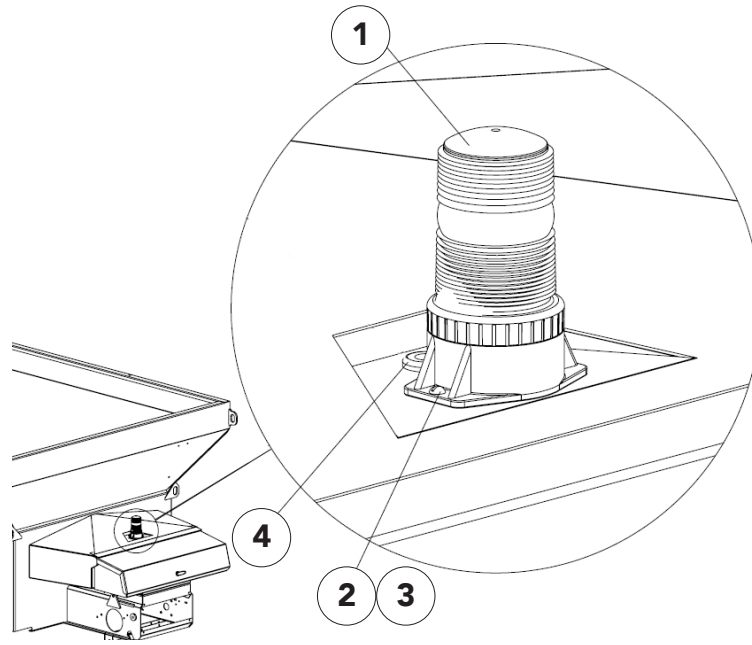

<u>ITEM</u>	<u>PART NO.</u>	<u>DESCRIPTION</u>	<u>QTY</u>
1	308188	Strobe- 360	1
	308187	Beacon- Revolving	1
2	*47264	Screw- Round #10-24NC x .75 SS	2
3	*56355	Nut- Lock #10-24NC SS	2
4	*21985	Grommet- Rubber .75	1

* - Not required with 308187

Dump Body Mount Safety Strap

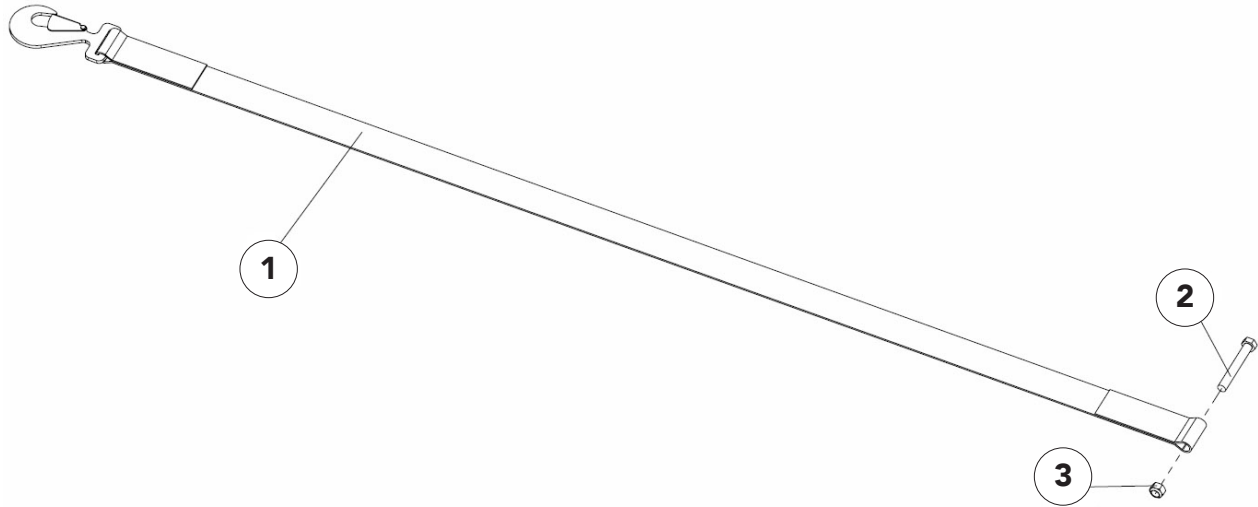

<u>ITEM</u>	<u>PART NO.</u>	<u>DESCRIPTION</u>	<u>QTY</u>
1	308090	Strap- Safety	1
2	20138-X1	Cap Screw- .5-13NC x 3.75	1
3	39016	Nut- Lock .5-13NC SS	1

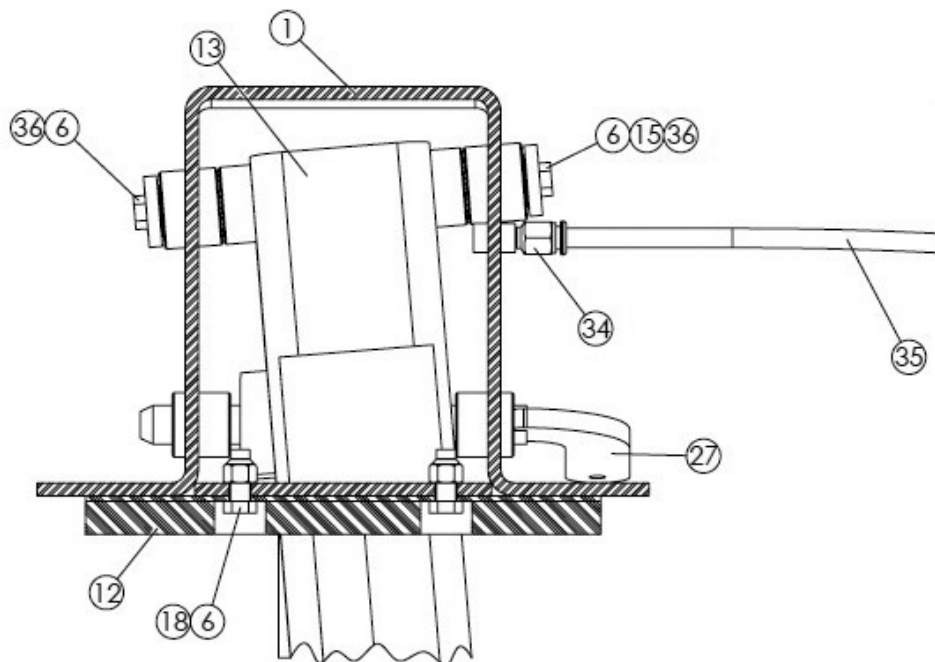
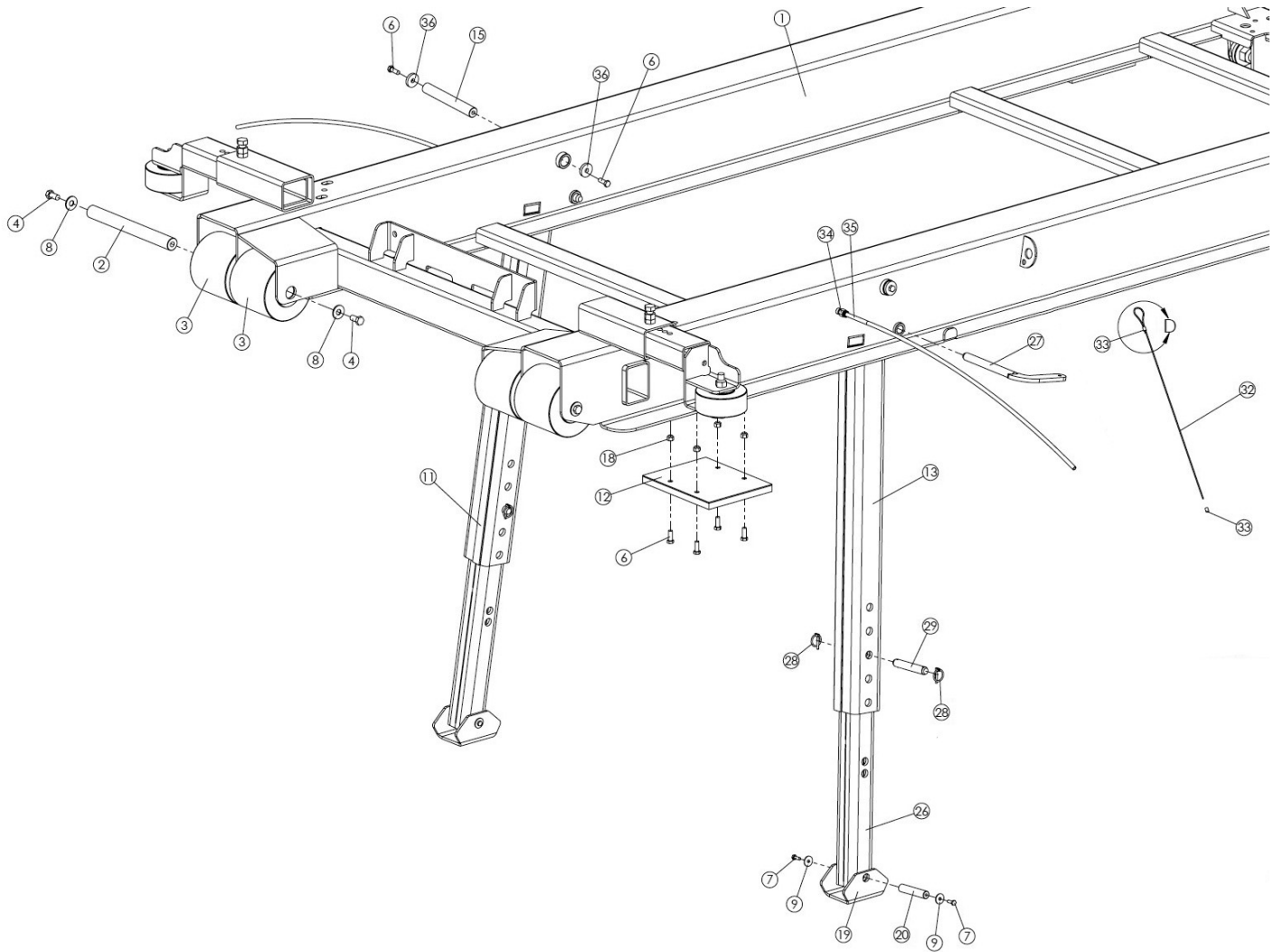

Subframe Continued

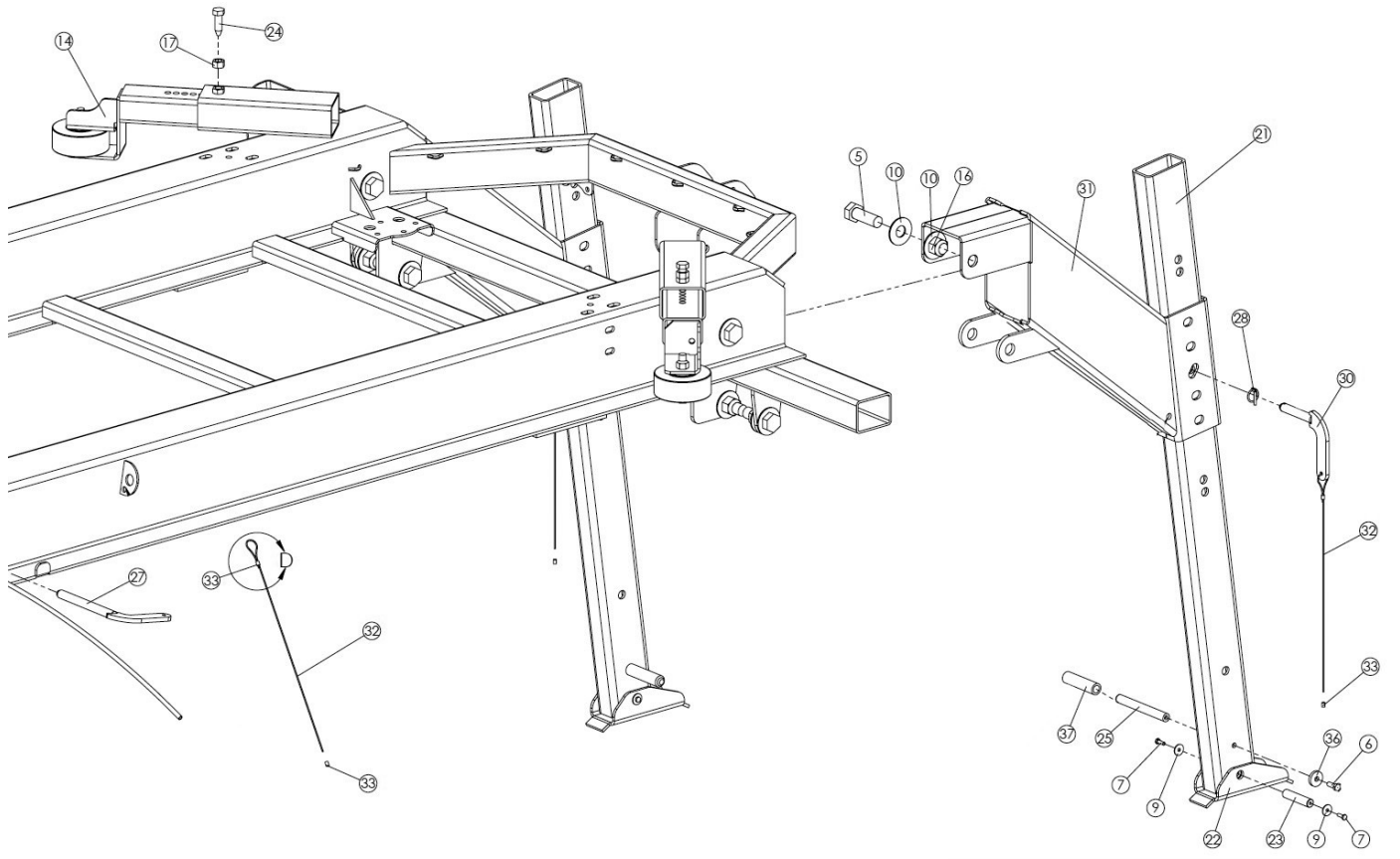

<u>ITEM</u>	<u>PART NO.</u>	<u>DESCRIPTION</u>	<u>QTY</u>
1	308068	Sub-frame- Galvanized 10'	1
	308338	Sub-frame- Galvanized 12'	
	308339	Sub-frame- Galvanized 14'	
2	307790	Axle- wheel sub-frame 304	2
3	307764	Wheel- Mount roll-on	4
4	36401	Cap Screw- .5-13NC x 1 SS	4
5	308086	Cap Screw- 1-8NC x 2.5 SS	8
6	36398	Cap Screw- .375-16NC x 1 SS	22
7	36393	Cap Screw- .25-20NC x .75 SS	8
8	308089	Washer- Fender .5 x 1.5 SS	4
9	308088	Washer- Fender .375 x 1.50 SS	8
10	307746	Spacer- .438 x .25 304	6
11	20700-X1	Washer- Flat 1 SS	16
12	308079	Leg- Assy front RH includes items 38-41	1
13	307794	Pad- Mount rubber	4
14	308078	Leg- Assy front LH includes items 37 and 39-41	1
15	307766	Assy- Guide Wheel includes items 42-45	4
16	307808	Pin- Hinge leg 304	2



Subframe Continued

<u>ITEM</u>	<u>PART NO.</u>	<u>DESCRIPTION</u>	<u>QTY</u>
17	308087	Nut- Lock 1-8NC SS	8
18	36417	Nut- Hex .625-11NC SS	4
19	72054	Nut- Lock .375-16NC SS	16
20	308074	Foot- Front galvanized	2
21	307809	Pin- Hinge foot front 304	2
22	308073	Leg- Rear galvanized	2
23	308075	Foot- Rear galvanized	2
24	307824	Pin- Hinge rear foot 304	2
25	307997	Cap Screw- .625-11NC x 2.5 SS modified	4
26	308001	Handle- Leg 304	2
27	308072	Leg- Front galvanized	2
28	308076	Pin- Lock zinc plated	2
29	308053	Pin- Lynch .188 x 1.25	6
30	308037	Pin- Leg front adjustment 304	2
31	308077	Pin- Rear leg pin plated	2
32	308069	Transition- Galvanized	2
33	308084	Cable- .094 x 24 coated	4
34	308085	Ferrule- .185 x .374	8
35	9005-0-7818	Fitting- 6-2 AA01028	2
36	9005-0-7797	Tubing- .375 OD air brake blue	AR
37	308070	Leg- Front LH galvanized	1
38	308071	Leg- Front RH galvanized	1
39	308080	Tape- Vhb 5952 black 1" x 45 mil	6 ft.
40	307806	Flat- 1 x .125 x 36 304	2
41	6072	Zerk- Grease	2
42	308238	Insert- Wldmt wheel guide	4
43	307765	Wheel- Guide side mount	4
44	90967	Cap Screw- .625-11NC x 4 SS	4
45	41762	Nut- Lock .625-11NC SS	4
46	308246	Handgrip- Foam Tube	2

AR- As Required

Truck Chassis Mount Subframe

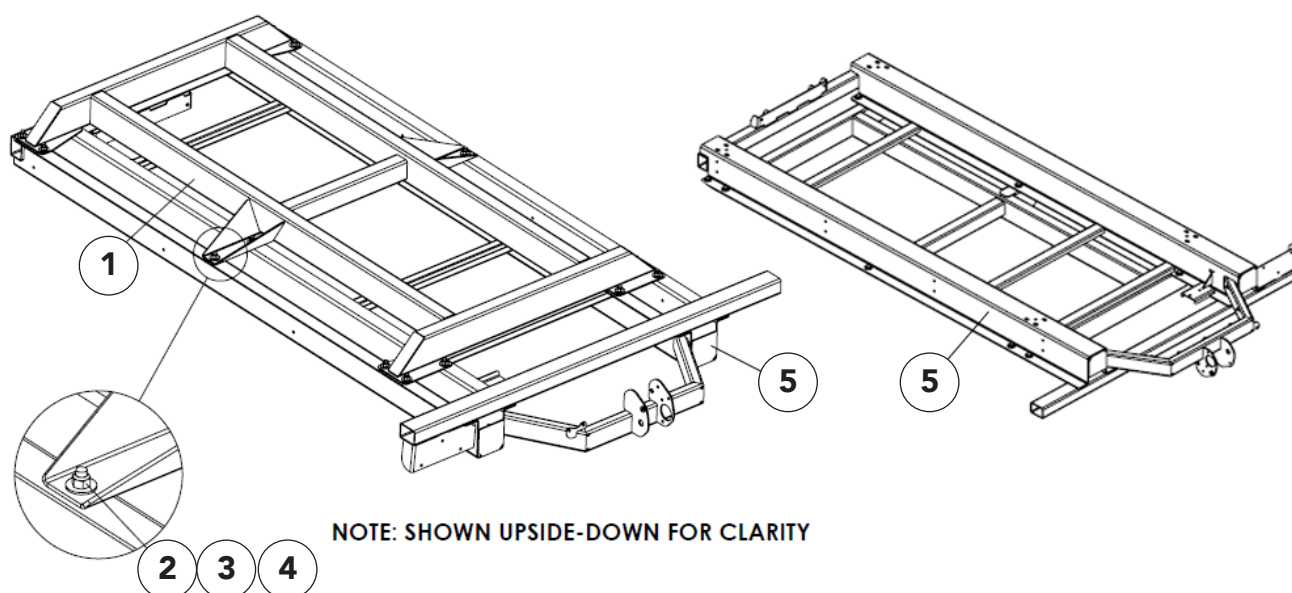

ITEM	PART NO.	DESCRIPTION	QTY
	309494	Frame- Group 10' Truck Chassis Mount, Includes 1-4	
	309495	Frame- Group 12' Truck Chassis Mount, Includes 1-4	
	309496	Frame- Group 14' Truck Chassis Mount, Includes 1-4	
1	309487	Frame- Wldmt 10'	1
	309482	Frame- Wldmt 12'	1
	309466	Frame- Wldmt 14'	1
2	20176	Cap Screw- 5/8-11NC x 1-3/4	AR
3	20697	Washer- Flat 5/8	AR
4	20682	Nut- Lock 5/8-11NC	AR
5	309484	Subframe- Wldmt 10'	1
	309479	Subframe- Wldmt 12'	1
	309464	Subframe- Wldmt 14'	1

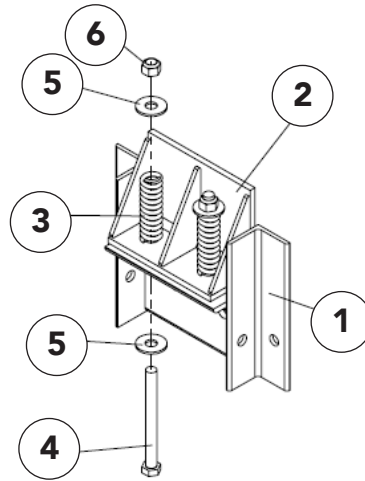

<u>ITEM</u>	<u>PART NO.</u>	<u>DESCRIPTION</u>	<u>QTY</u>
1	301624	Angle- Mount Wldmt	2
2	300275	Mount- Spring Wldmt	2
3	81000	Spring- Compression	4
4	20195	Cap Screw- 5/8-11NC x 6-1/2	4
5	20697	Washer- Flat 5/8	8
6	20682	Nut- Lock 5/8-11NC	4

NOTE: Rear mounts are supplied by installer.

Fenders - 100" Wide

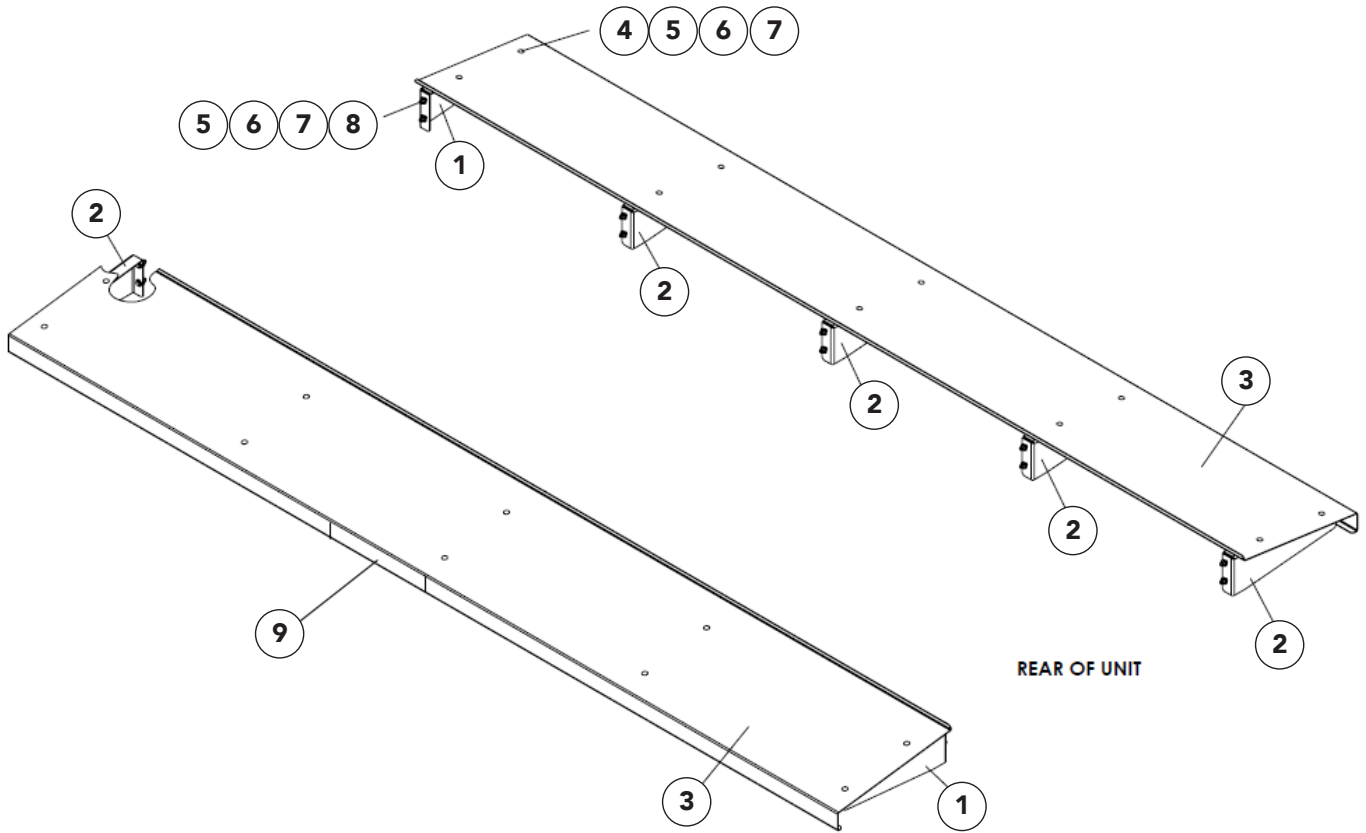

ITEM	PART NO.	DESCRIPTION	QTY
1	309470	Bracket- Fender LH 201	10' Unit 4
			14' Unit 5
2	309471	Bracket- Fender RH 201	10' Unit 4
			14' Unit 5
3	313020	Fender- Panel 10' 201	2
	309469	Fender- Panel 14' 201	2
4	36408	Bolt- Carriage 3/8-16NC x 1 SS	AR
5	36425	Washer- Flat 3/8 SS	AR
6	36420	Washer- Lock 3/8 SS	AR
7	36414	Nut- Hex 3/8-16NC SS	AR
8	36399	Cap Screw- 3/8-16NC x 1-1/4 SS	AR
9	39200	Decal- Warning Slipping Hazard	2

AR- As Required



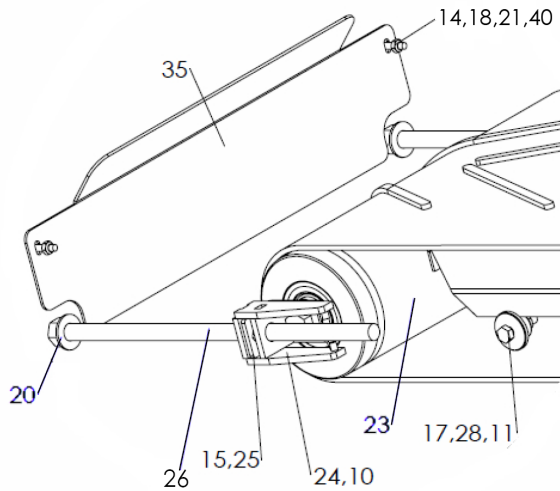
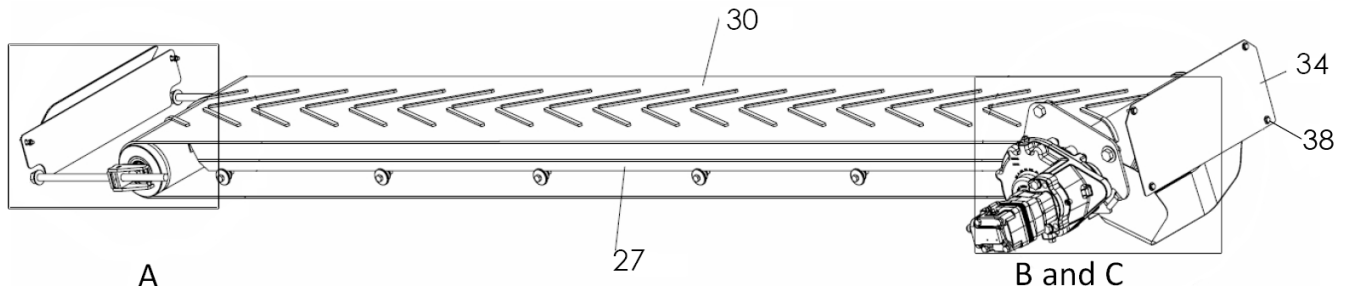

DETAIL A

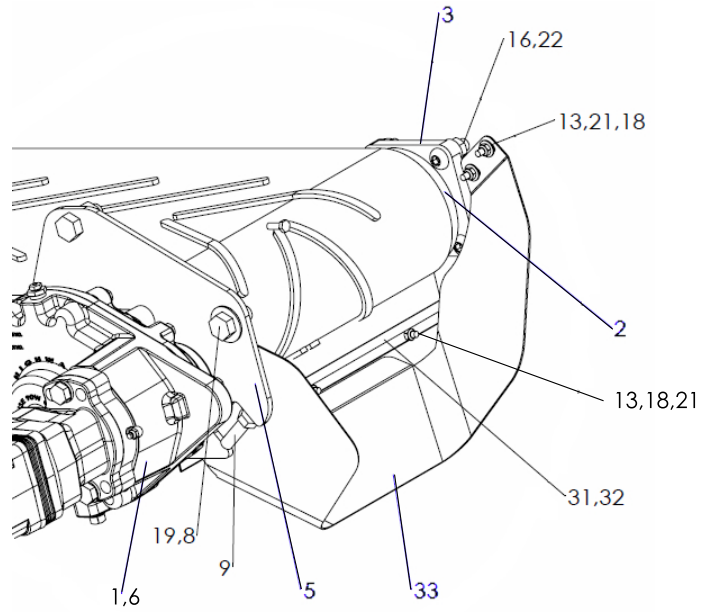

DETAIL B

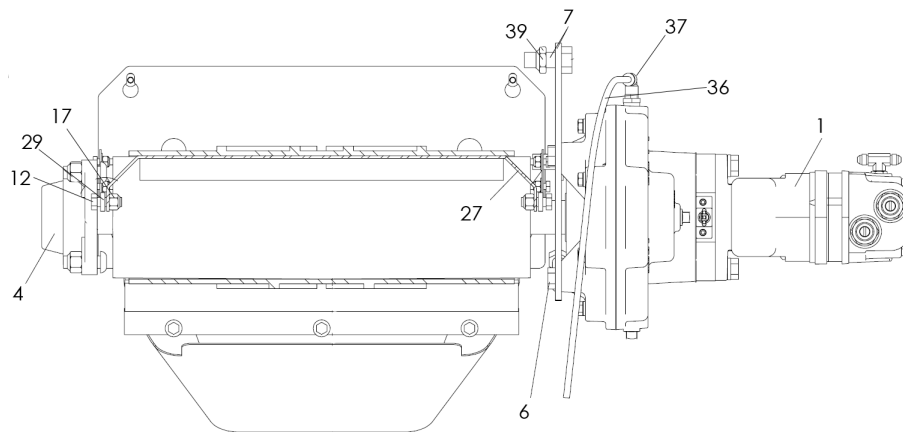

DETAIL C

Conveyor Group Continued

<u>ITEM</u>	<u>PART NO.</u>	<u>DESCRIPTION</u>	<u>QTY</u>
1	307995	Gear Case- Assy Single Pinion 6:1 * parts list under "Gear Case"	1
2	307934	Roller- Drive Crowned	1
3	307958	Bearing- 4BF 1.375 Bore Composite	1
4	307981	Cap- Bearing Closed	1
5	307954	Mount- Gear Case 304	1
6	36401	Cap Screw- .5-13NC x 1 SS	4
7	307960	Cap Screw- .625-11NC x 1.5 SS	1
8	34857	Cap Screw- .625-11NC x 1.25 SS	1
9	307959	Cap Screw- .5-13NC x 1.75 SS Fully Threaded	1
10	308217	Cap Screw- .625-18NF x 1.75 SS	2
11	34858	Cap Screw- .375-16NC x 1.5 SS	AR
12	36398	Cap Screw- .375-16NC x 1 SS	2
13	36393	Cap Screw- .25-20NC x .75 SS	10
14	40750	Cap Screw- .25-20NC x 1.25 SS	2
15	36417	Nut- Hex .625-11NC SS	2
16	39016	Nut- Lock .5-13NC SS	4
17	72054	Nut- Lock .375-16NC SS	AR
18	42034	Nut- Lock .25-20NC SS	12
19	56857	Washer- Flat .625 SS	1
20	307977	Washer- Flat .625 SAE SS	2
21	36423	Washer- Flat .25 SS	14
22	304484	Screw- Buttonhead .5-13NC x 1.5	4
23	307933	Roller- Assy Idler * parts list under "Idler Assembly"	1
24	307962	Take-up- Wldmt 304	2
25	307966	Retainer- Nut 304	2
26	307991	Take-up- Wldmt Bolt	2
27	307989	Bottom- Panel 10' 304	1
	308348	Bottom- Panel 12' 304	1
	308349	Bottom- Panel 14' 304	1
28	307990	Support- Bottom Panel 304	AR
29	307996	Spacer- .391 ID x 7GA 304	2
30	307762	Belt- Endless 240	1
	308350	Belt- Endless 288	1
	308351	Belt- Endless 336	1
31	307998	Holder- Brush 16" SS	2
32	307781	Brush- Strip	2
33	310672	Chute- Conveyor Coated 304	1



Conveyor Group Continued

<u>ITEM</u>	<u>PART NO.</u>	<u>DESCRIPTION</u>	<u>QTY</u>
34	308128	Cover- Conveyor Rear 304	1
35	380127	Cover- Conveyor Front 304	1
36	9005-0-7761	Tubing- .25 OD Air Brake	1.5 ft.
37	306891	Fitting- 4-2 630202K	1
38	308239	Cap Screw- Flange .25-20NC x .75 SS	4
39	56288	Nut- Lock Thin .625-11NC SS	1
40	36412	Nut- Hex .25-20NC SS	2

AR- As Required



Belt Shields

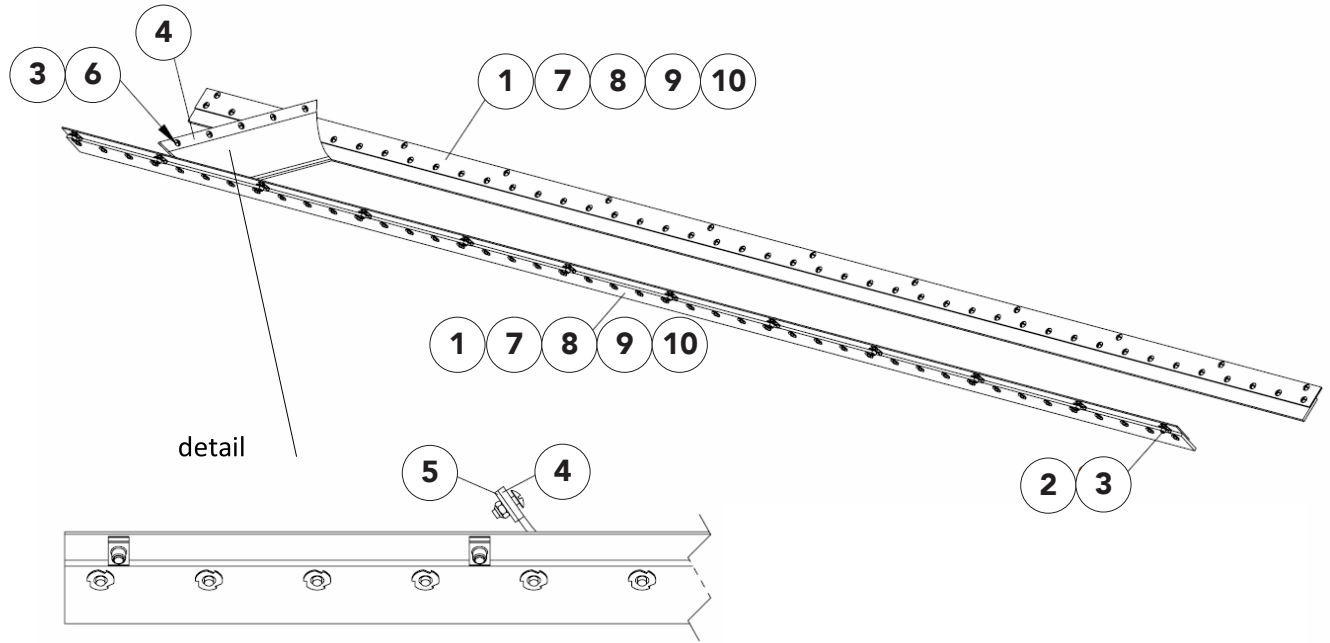

<u>ITEM</u>	<u>PART NO.</u>		<u>DESCRIPTION</u>	<u>QTY</u>
	<u>CS</u>	<u>304</u>		
1	308123	308309	Shield- Chain Assy 10' includes 7-10	2
	308354	308360	Shield- Chain Assy 12' includes 7-10	2
	308355	308361	Shield- Chain Assy 14' includes 7-10	2
2	300252	300252	U-Nut .25-20	AR
3	21378	32446	Screw- Truss Head .25-20NC x .75	AR
4	308125	308125	Belt- Wiper Front	1
5	308126	308311	Retainer- Belt	1
6	20676	42034	Nut- Lock .25-20NC	5
7	308124	308310	Shield- Chain 10'	2
	308356	308362	Shield- Chain 12'	2
	308357	308363	Shield- Chain 14'	2
8	53950	53950	Belting	AR
9	88931	88931	Nut- Tee .25 x .25	AR
10	20624	56258	Screw- Truss Head .25-20NC x .5	AR

AR- As Required



This page is intentionally left blank.

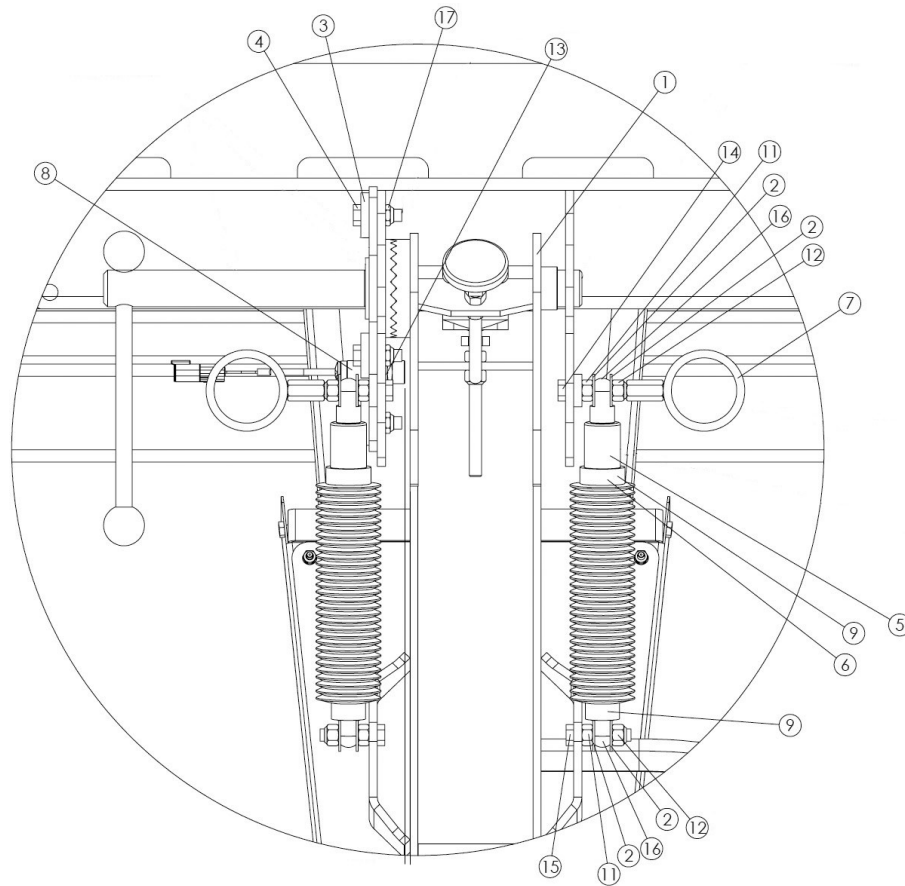

<u>ITEM</u>	<u>PART NO.</u>	<u>DESCRIPTION</u>	<u>QTY</u>
1	308057	Spinner- Assy	1
2	36425	Washer- Flat .375 SS	8
3	307746	Spacer- .438id X .25 304	3
4	36399	Capscrew- .375-16nc X 1.25 SS	3
5	307972	Spring- Gas	2
6	307969	Bellows- Rod	2
7	307984	Ring- Wldmt 304	2
8	308179	Sensor- 18mm W/Dtm04-3p 57	1
9	*99674	Strap- Zip Tie 8 Black	4
10	*301315	Loctite- 243	0
11	36414	Nut- Hex .375-16nc SS	4
12	72054	Nut- Lock .375-16nc SS	4
13	308237	Washer- Star Internal 18mm SS	2
14	308224	Capscrew- .375-16nc X 2.5 Gr8	2
15	308225	Capscrew- .375-16nc X 1.75	2
16	308315	Rod- End 304	4
17	307395	Nut- Lock Thin .375-16nc SS	3

* Not Shown



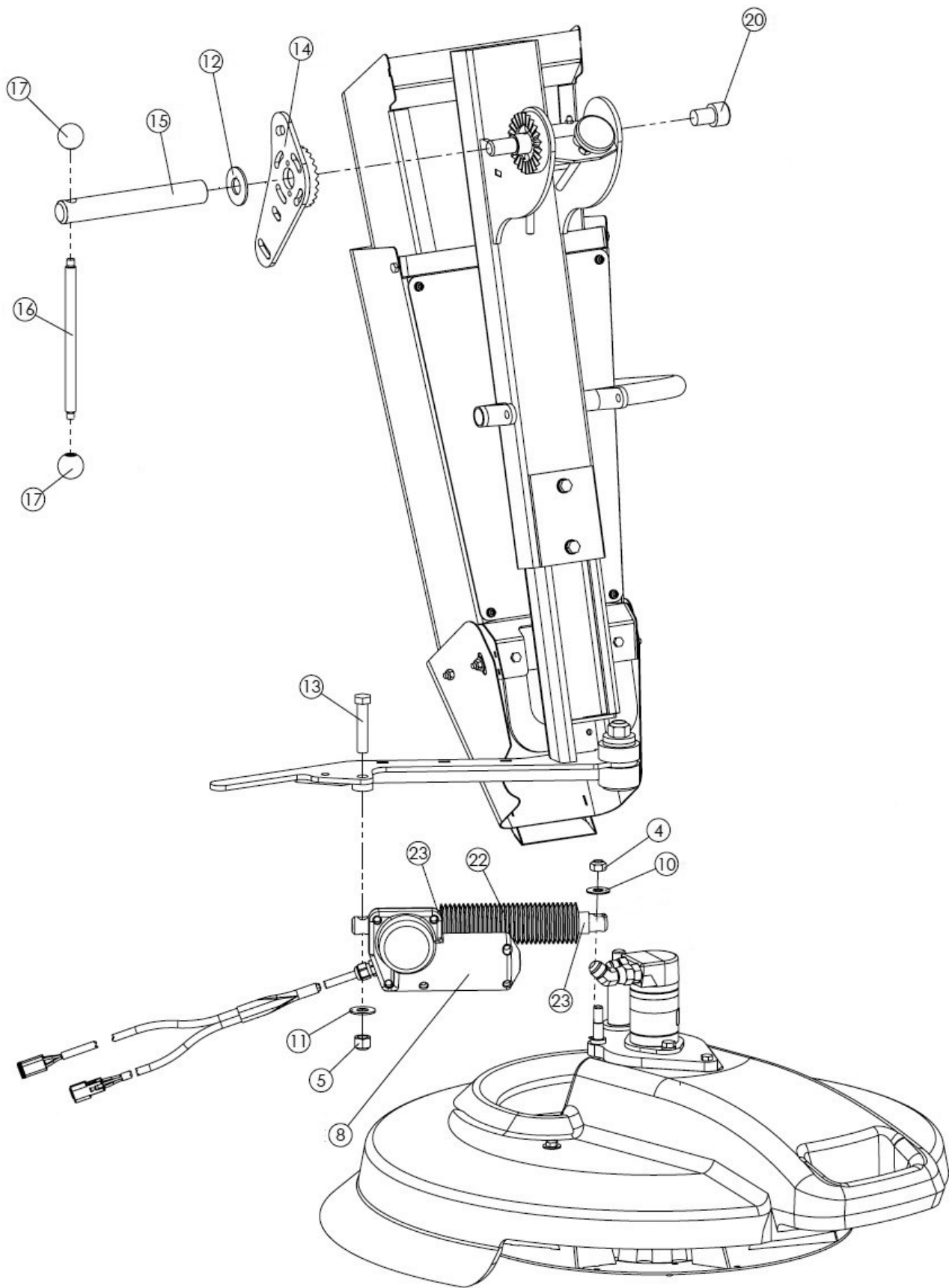

Spinner Assembly Continued

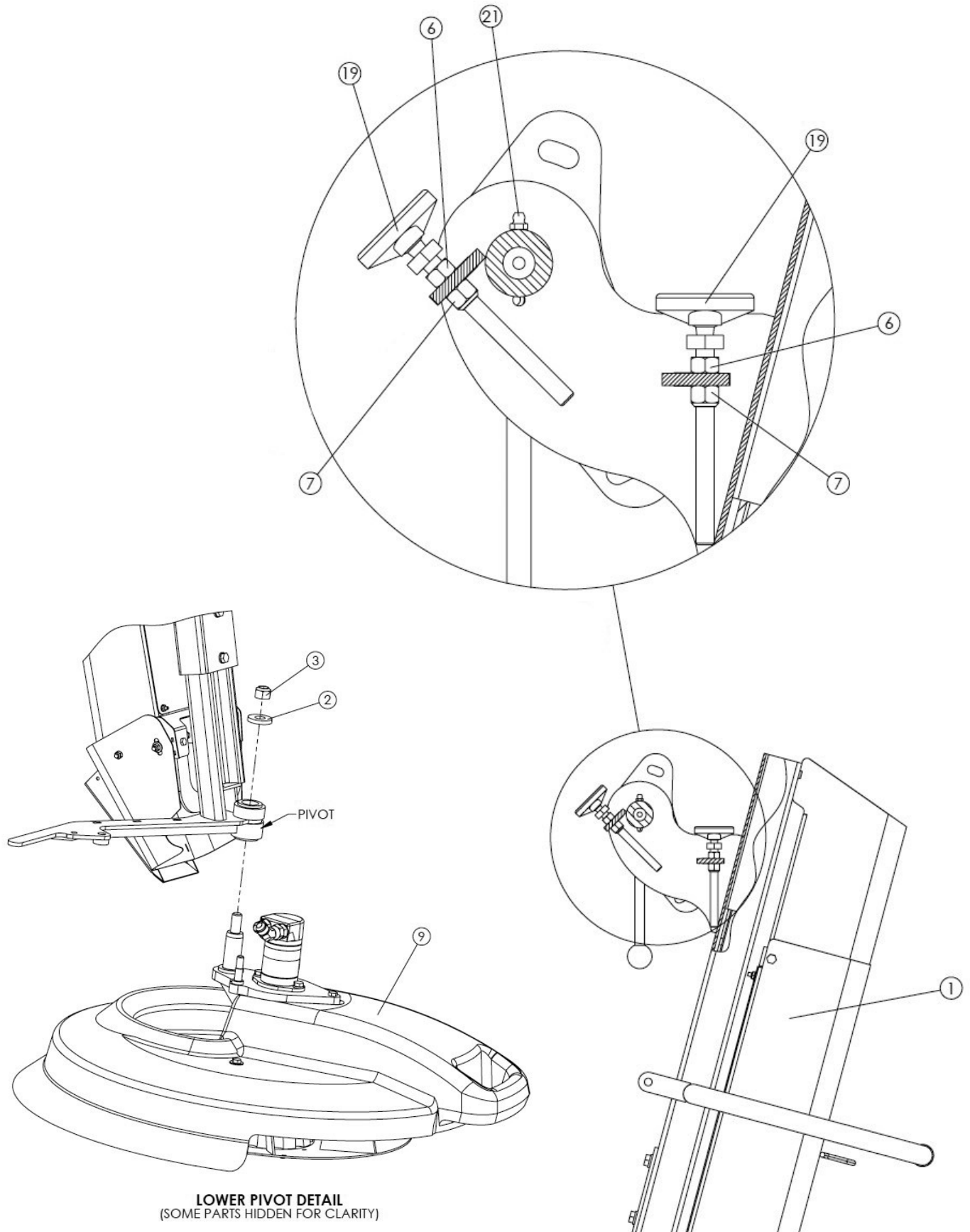

LOWER PIVOT DETAIL
(SOME PARTS HIDDEN FOR CLARITY)



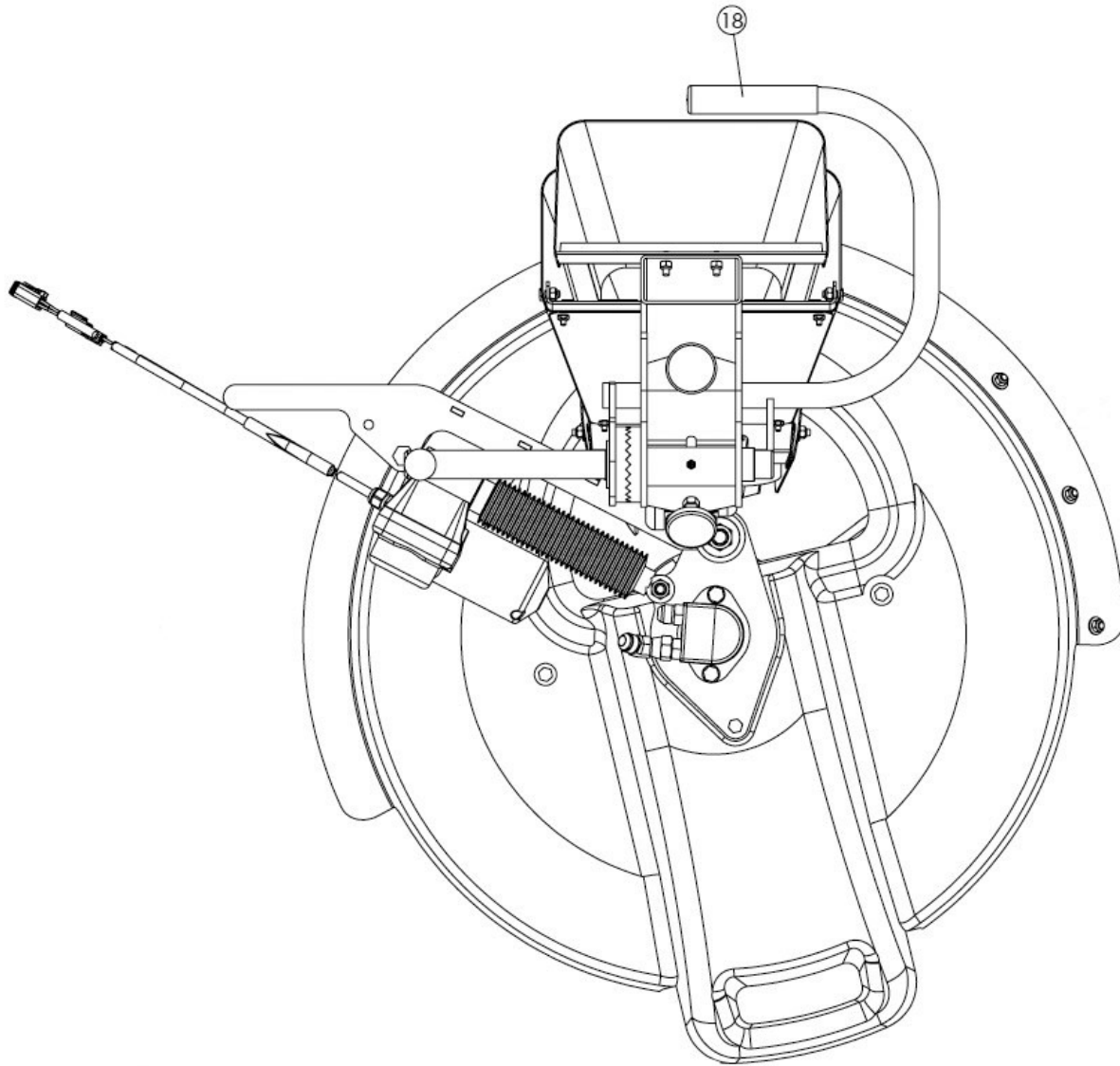

Spinner Assembly Continued

<u>ITEM</u>	<u>PART NO.</u>	<u>DESCRIPTION</u>	<u>QTY</u>
1	307827	Chute- Assy 304	1
2	307935	Washer- 1.563od X .656id X .250 304	1
3	41762	Nut- Lock .625-11nc SS	1
4	307987	Nut- Lock .438-20nf SS	1
5	39016	Nut- Lock .5-13nc SS	1
6	36414	Nut- Hex .375-16nc SS	2
7	72054	Nut- Lock .375-16nc SS	2
8	310168	Actuator- Linear Electric	1
9	307861	Spinner- Assy Lower	1
10	36295	Washer- Flat .438 SS	1
11	36426	Washer- Flat .5 SS	1
12	56408	Washer- Flat .75 SS	1
13	42454	Capscrew- .5-13nc X 2.5 SS	1
14	307914	Lock- Wldmt Chute 304	1
15	307916	Bar- Chute Rotation Lock 304	1
16	307917	Handle- 304	1
17	307918	Knob- 1.25	2
18	307953	Grip- Round Vinyl	1
19	307973	Foot- Leveling Swivel SS	2
20	307920	Screw- Socket Hd .75-10nc X 1	1
21	6072	Zerk- Grease 1/4-28nf Strght	1
22	307969	Bellows- Rod	1
23	99674	Strap- Zip Tie 8 Black	2



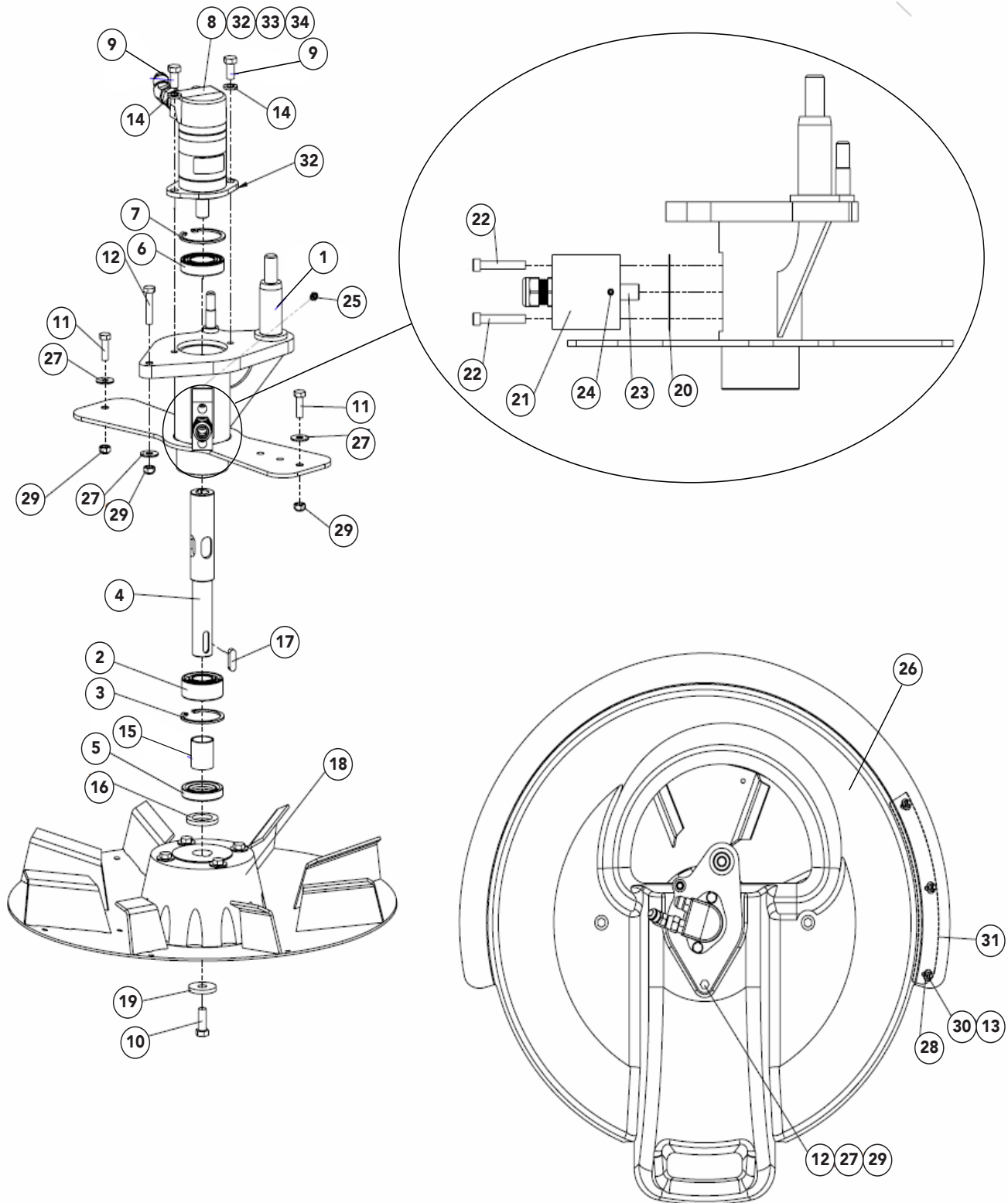

Lower Spinner Assembly Continued

<u>ITEM</u>	<u>PART NO.</u>	<u>DESCRIPTION</u>	<u>QTY</u>
1	307883	OHLA- Wldmt 304	1
2	307876	Bearing- Ball Double Row 25mm	1
3	307877	Ring- Snap Internal 52mm	1
4	307873	Shaft- OHLA 304	1
5	307881	Seal- Shaft 28mm	1
6	307878	Bearing- Ball 30mm	1
7	307879	Ring- Snap Internal 55mm	1
8	307967	Motor- Assy Hyd includes items 32-34	1
9	36293	Cap Screw- .375-16NC x .75 SS	2
10	312456	Cap Screw- .375-16NC x 1 SS w/ Nylon Strip	1
11	34580	Cap Screw- .313-18NC x 1 SS	2
12	308056	Cap Screw- .313-18NC x 1.5 SS	1
13	36394	Cap Screw- .25-20NC x .875 SS	3
14	36420	Washer- Lock .375 SS	2
15	307882	Spacer- Spinner 304	1
16	307880	Spacer- 1.000 ID x 7 GA 304	1
17	307747	Key- Rect .313 x .25 x 1 SS	1
18	307773	Spinner- Disc Assy * parts list under "Spinner Disc Assembly"	1
19	307746	Spacer- .438 ID x 7GA 304	1
20	307885	Gasket- Mount Sensor	1
21	307884	Block- Sensor	1
22	308047	Cap Screw- Socket HD .25-20NC x 1.5 SS	2
23	308177	Sensor- 12mm	1
24	308048	Screw- Set Nylon Tip #10-24NC x .25 SS	1
25	6072	Zerk- Grease	1
26	307919	Shroud- Spinner	1
27	36424	Washer- Flat .313 SS	3
28	36423	Washer- Flat .25 SS	6
29	42221	Nut- Lock .313-18NC SS	3
30	42034	Nut- Lock .25-20NC SS	3
31	307961	Strip- Wear 304	1
32	307783	Motor- Hyd 1.21 CID	1
33	34809	Fitting- 8-6 070120	2
34	34805	Fitting- 8-8 070321	1



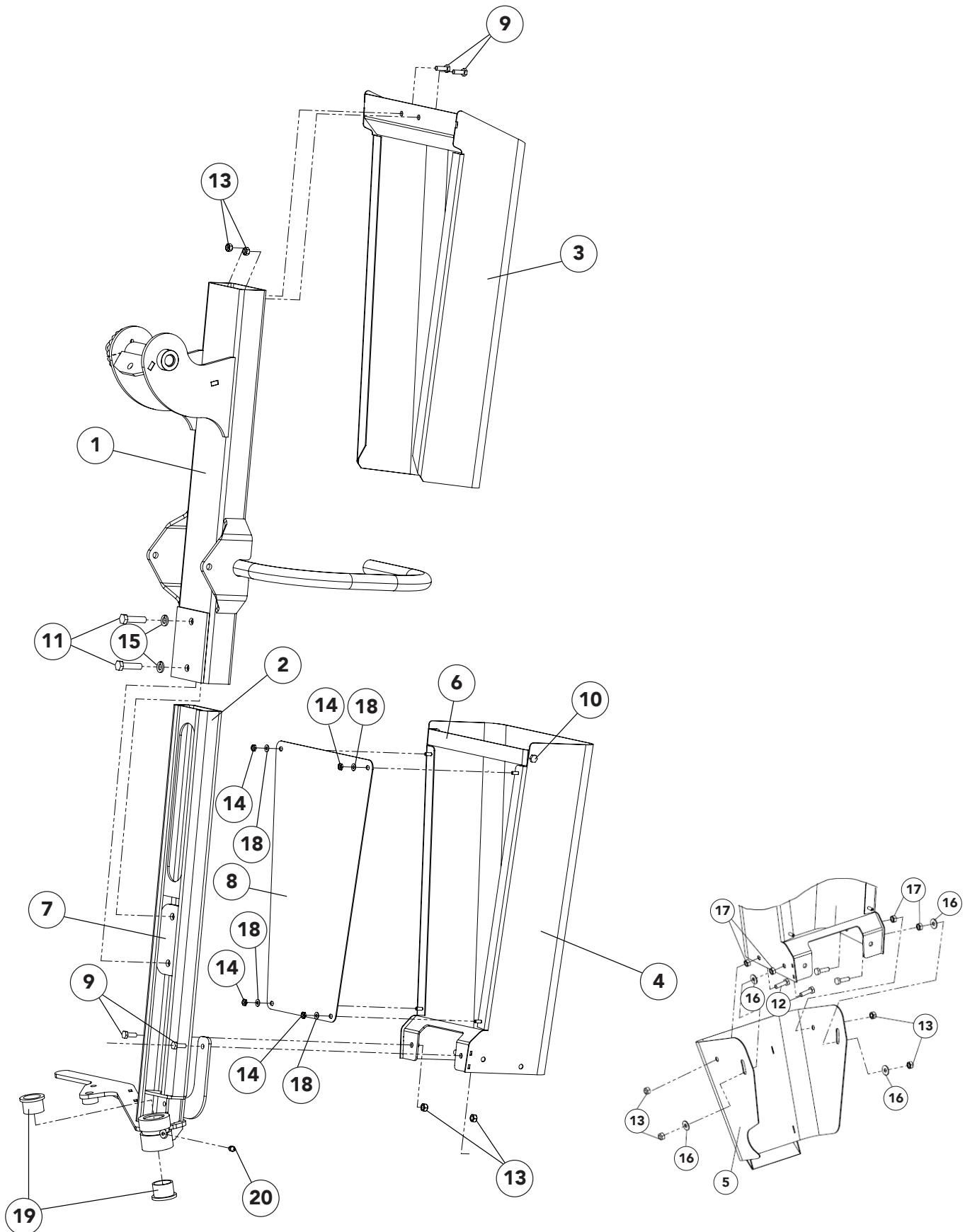

Chute Assembly Continued

<u>ITEM</u>	<u>PART NO.</u>	<u>DESCRIPTION</u>	<u>QTY</u>
1	307828	Support- Wldmt chute upper 304	1
2	307833	Lower Chute Support- Wldmt 304	1
3	313904	Chute- Wldmt upper 304	1
4	313905	Chute- Wldmt lower 304	1
5	308059	Chute- Lower deflector coated 304	1
6	308312	Bracket- Wldmt Lower Chute 304	1
7	307853	Chute Lock Plate- Wldmt 304	1
8	307856	Cover- Lower chute 304	1
9	36393	Cap Screw- .25-20NC x .75 SS	4
10	308227	Cap Screw- .25-20NC x .625 SS	2
11	34858	Cap Screw- .375-16NC x 1.5 SS	2
12	36394	Cap Screw- .25-20NC x .875 SS	4
13	42034	Nut- Lock .25-20NC SS	10
14	307974	Nut- Lock #10-32NF SS	4
15	36420	Washer- Lock .375 SS	2
16	36423	Washer- Flat .25 SS	4
17	36412	Nut- Hex .25-20NC SS	4
18	171052	Washer- Flat SS	4
19	307887	Bearing- Flanged Bronze	2
20	311663	Zerk- Grease .25-28 SS	1



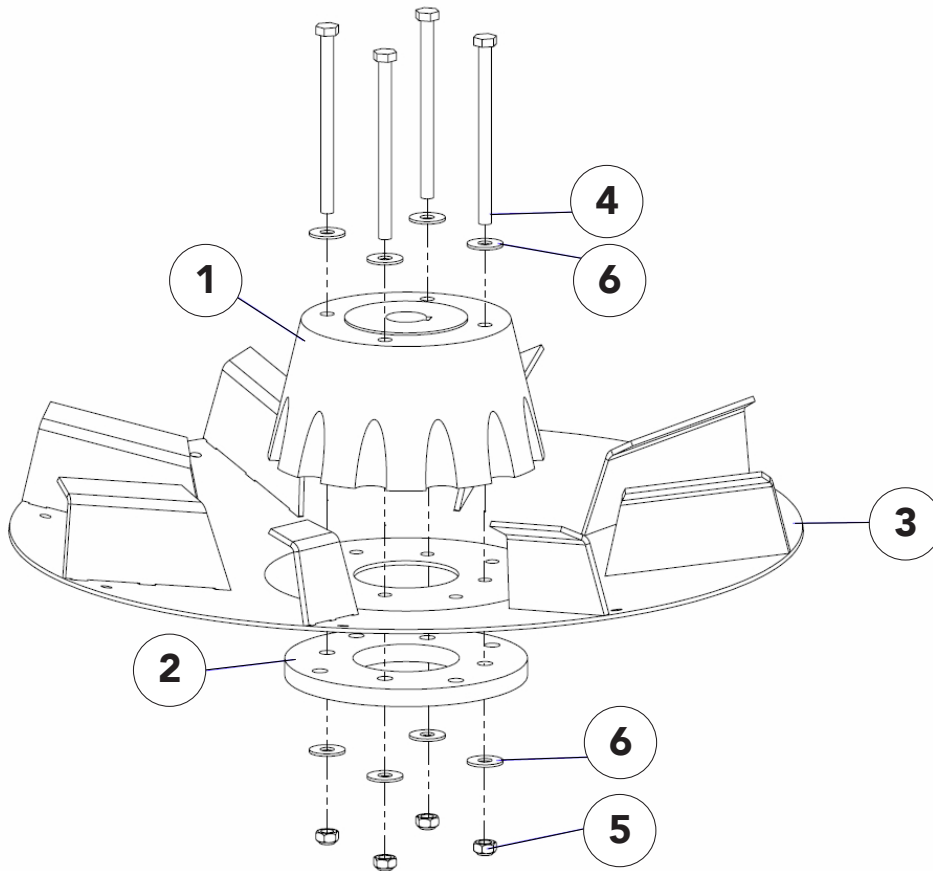

<u>ITEM</u>	<u>PART NO.</u>	<u>DESCRIPTION</u>	<u>QTY</u>
1	307776	Hub	1
2	307777	Hub- Bottom Doubler	1
3	307774	Spinner- Wldmt Disc 304	1
4	307921	Cap Screw- .313-18NC x 4.5 SS	4
5	42221	Nut- Lock .313-18NC SS	4
6	36424	Washer- Flat .313 SS	8

Spinner Flood Light

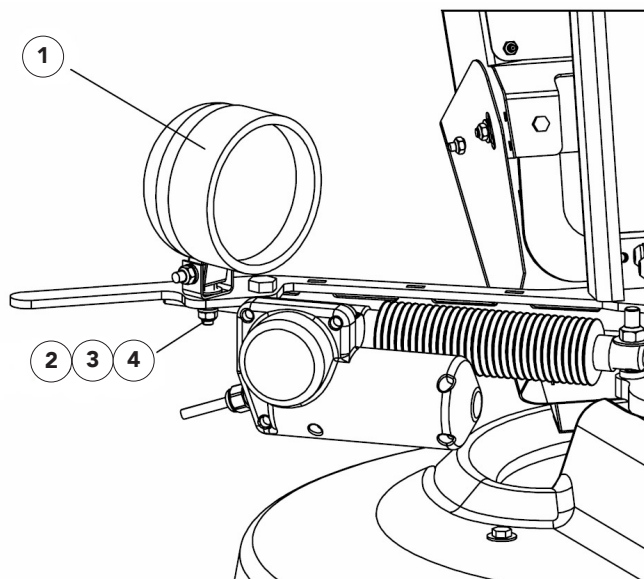

<u>ITEM</u>	<u>PART NO.</u>	<u>DESCRIPTION</u>	<u>QTY</u>
1	308189	Light- Work/Flood	1
2	36424	Washer- Flat .313 SS	2
3	42221	Nut- Lock .313- 18NC SS	1
4	34580	Cap Screw- .313- 18NC x 1 SS	1

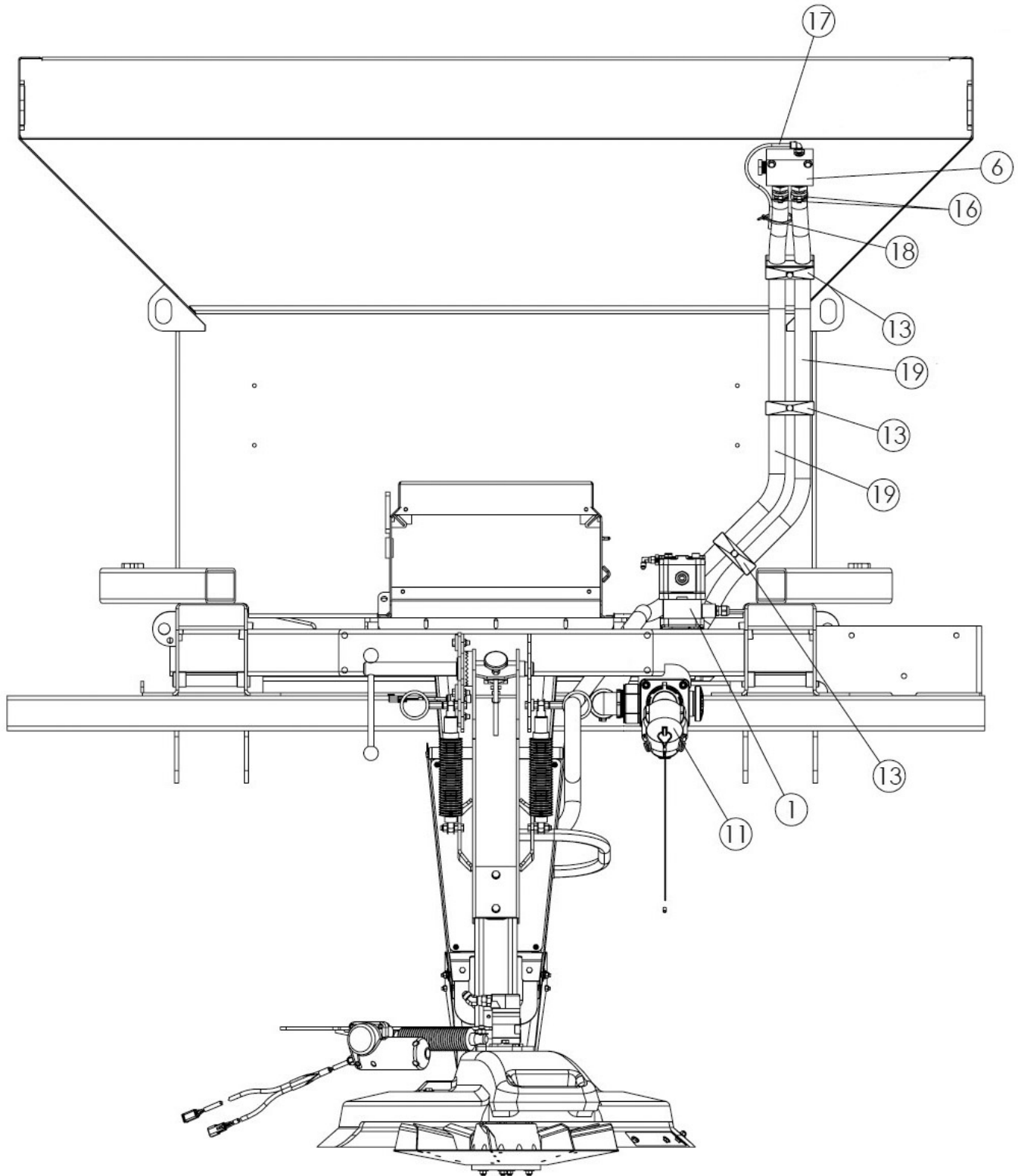

Liquid Pump System Continued

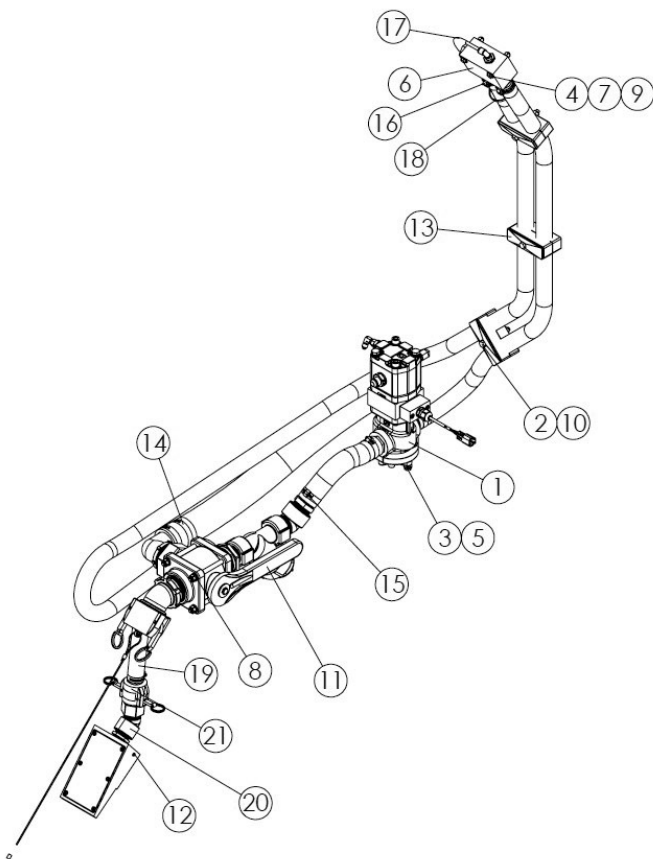
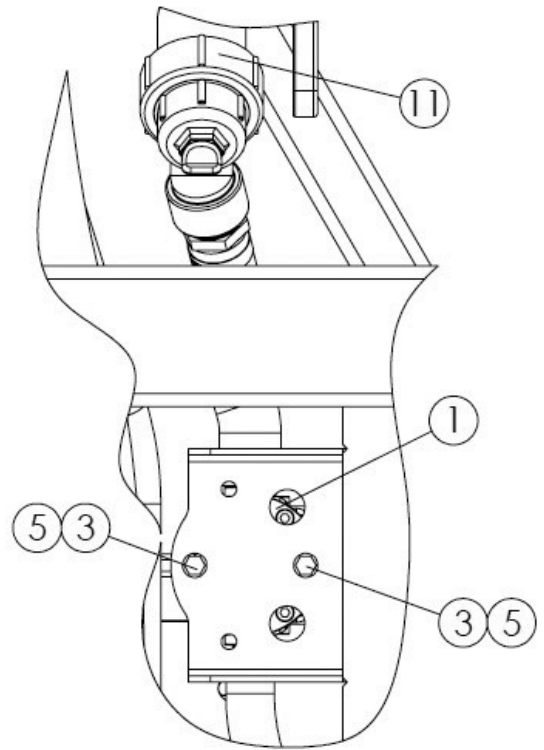
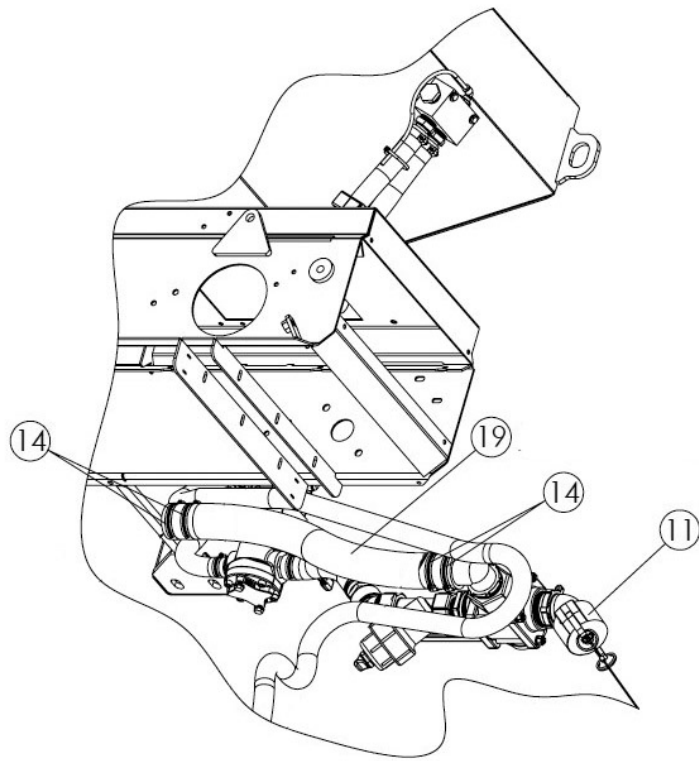

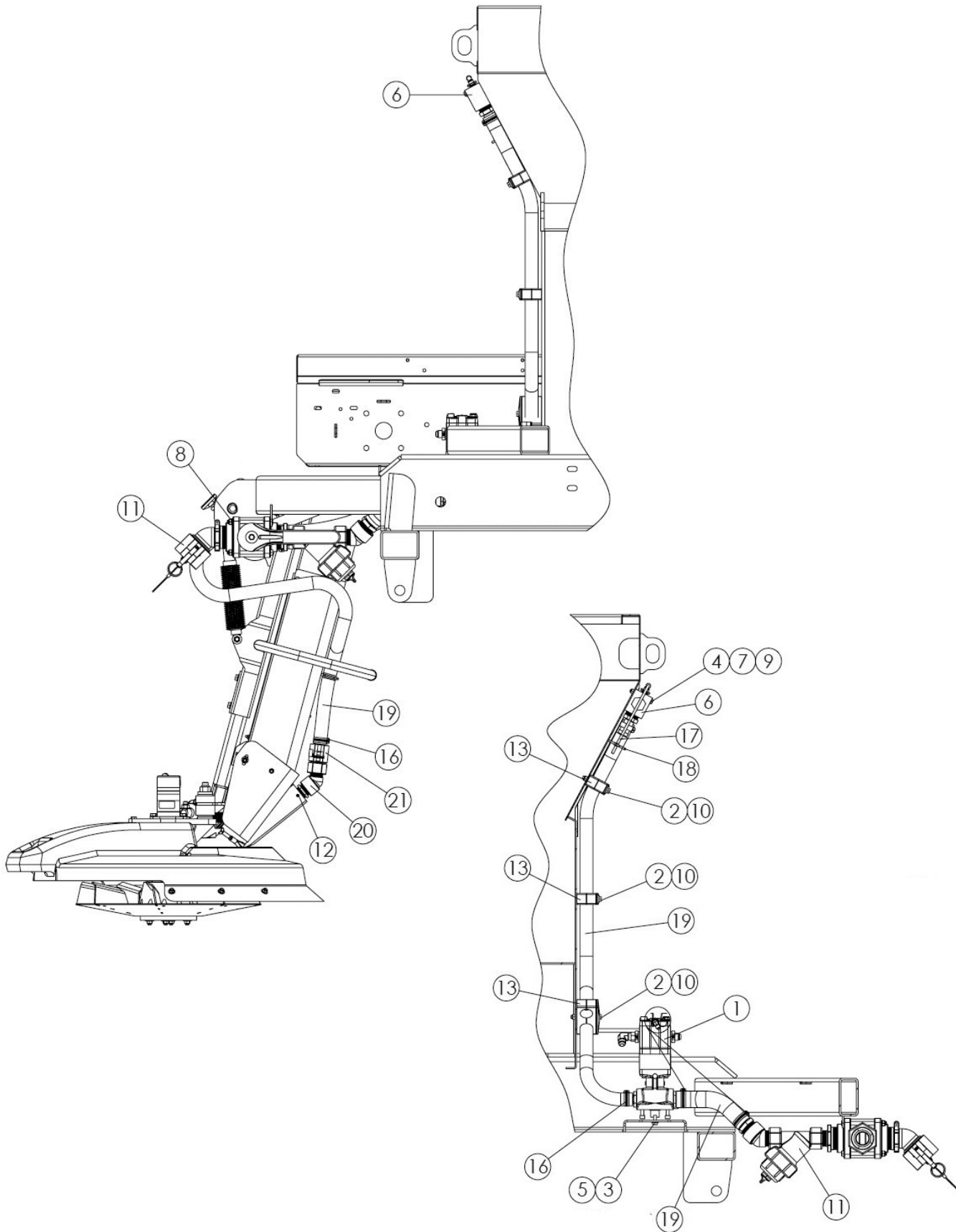

Liquid Pump System Continued

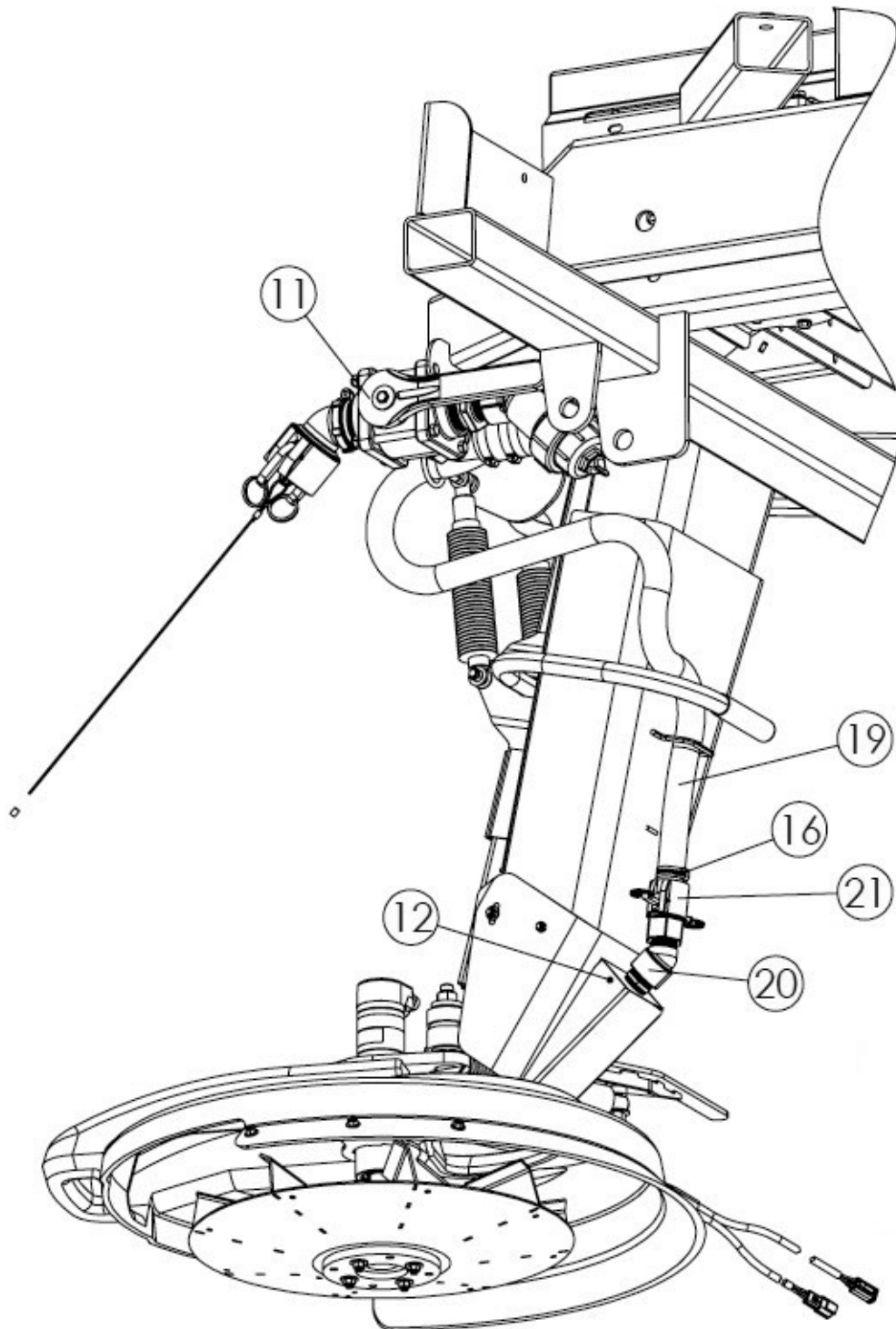

LIQUID DIFFUSER PLUMBING



Liquid Pump System Continued

<u>ITEM</u>	<u>PART NO.</u>	<u>DESCRIPTION</u>	<u>QTY</u>
1	308043	Pump- Assy Prewet	1
2	96258	Capscrew- .313-18nc X 3 SS	3
3	308040	Capscrew- M8 X 20 SS	2
4	34501	Capscrew- .25-20nc X 2.5 SS	2
5	36420	Washer- Lock .375 SS	2
6	308011	Manifold- Assy Anti-Siphon	1
7	36423	Washer- Flat .25 SS	2
8	307395	Nut- Lock Thin .375-16nc SS	2
9	42034	Nut- Lock .25-20nc SS	2
10	42221	Nut- Lock .313-18nc SS	3
11	308019	Valve- Assy Fill/Pump Poly	1
12	56315	Screw- Self Drilling #6-20nc	2
13	308033	Clamp- Tubing 1.33 Twin	3
14	321848	Clamp- Hose T-Bolt SS	4
15	321799	Clamp- Hose Sae 24 SS	2
16	321849	Clamp- Hose Sae 16 SS	4
17	9005-0-7761	Tube- .25od Air Brake Black	1
18	306836	Strap- Zip Tie .18 X 11 Black	1
19	309426	Hose- Group Liquid	1
20	310678	Diffuser- Assy	1
21	310675	Coupling- 1 Female X 1 Hose	1
22	96942	Tie- Wire Hd 29 Long	2
23	308241	Sealant- Rtv 732	0

* Not Shown

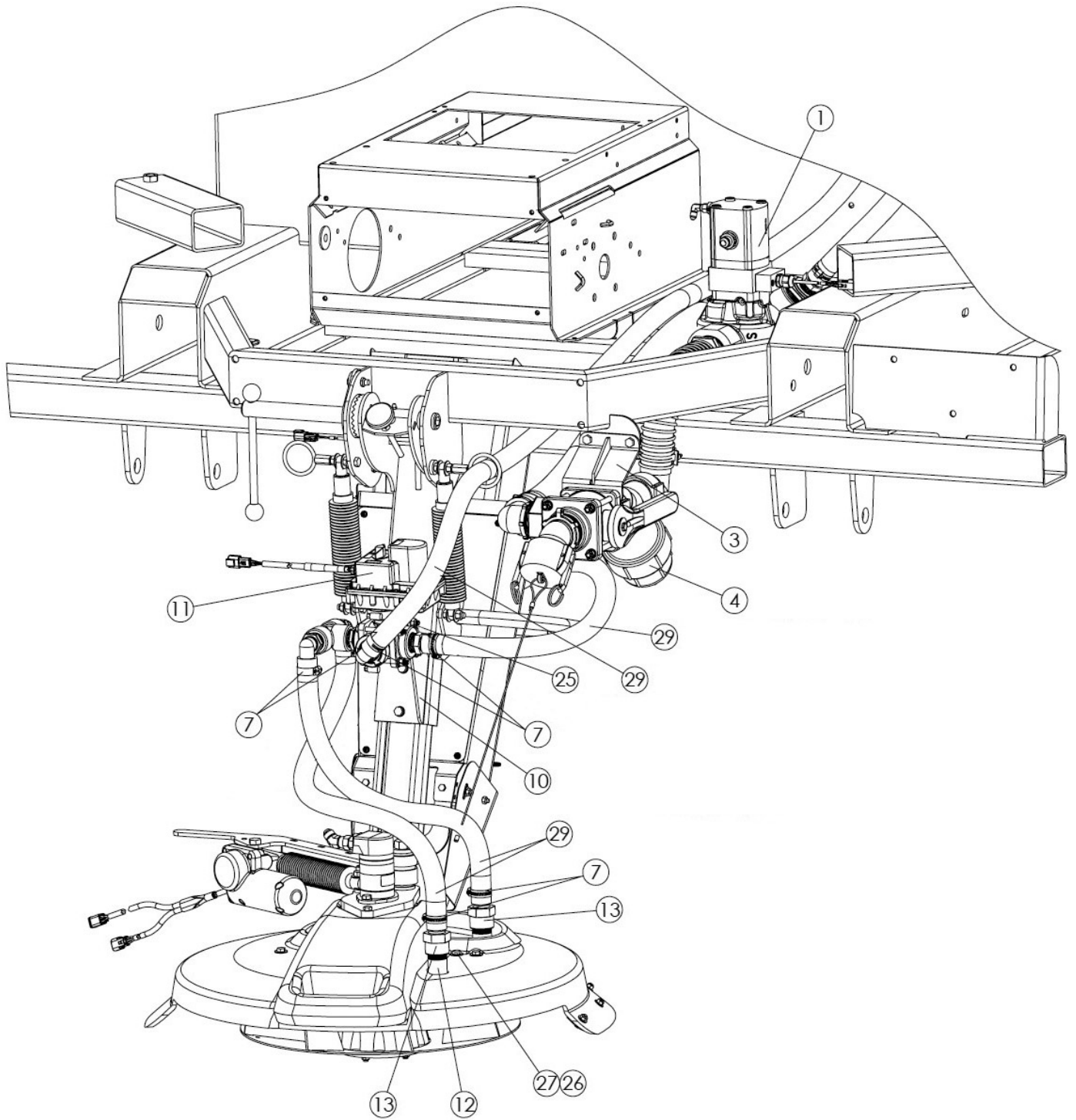

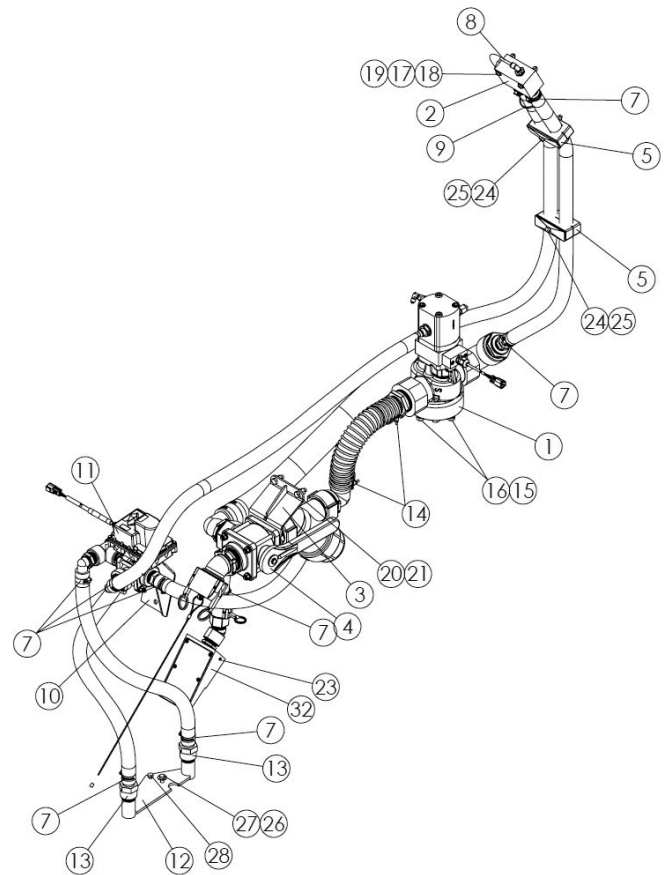
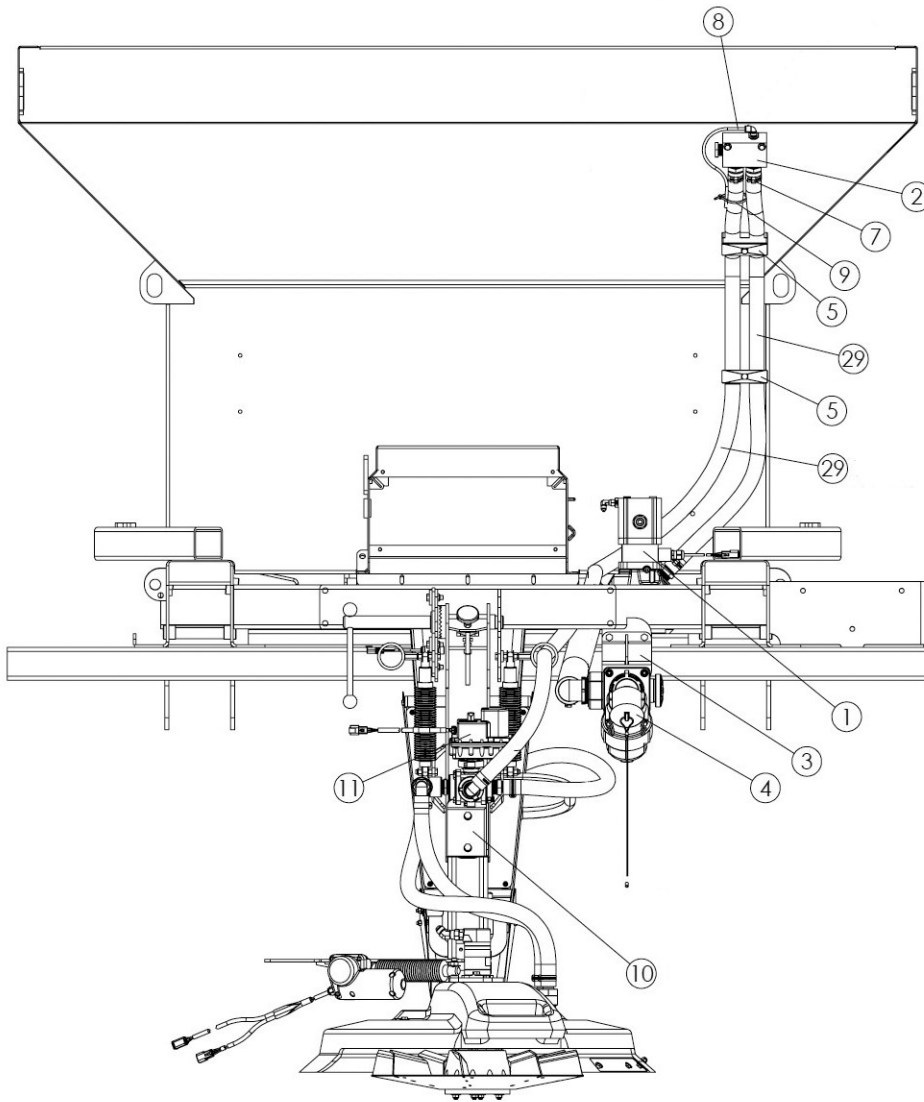

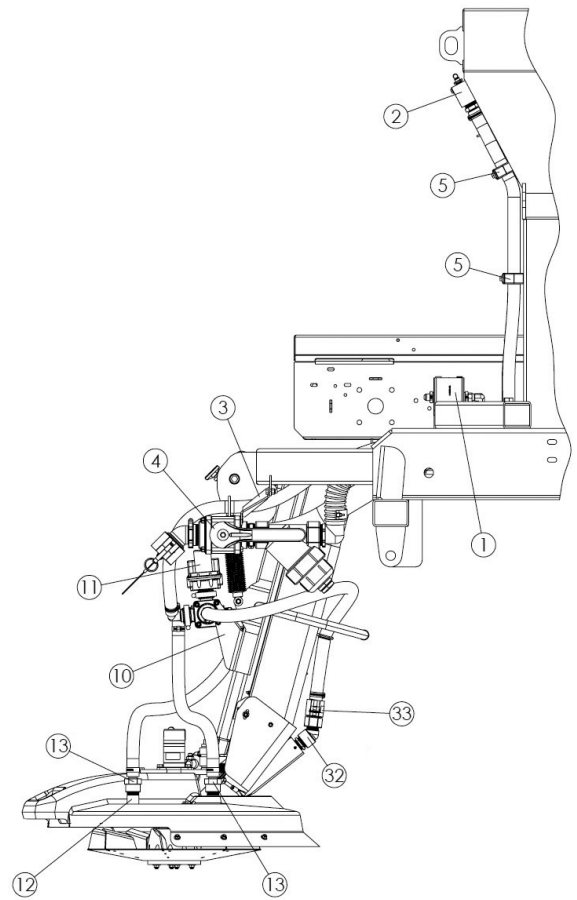
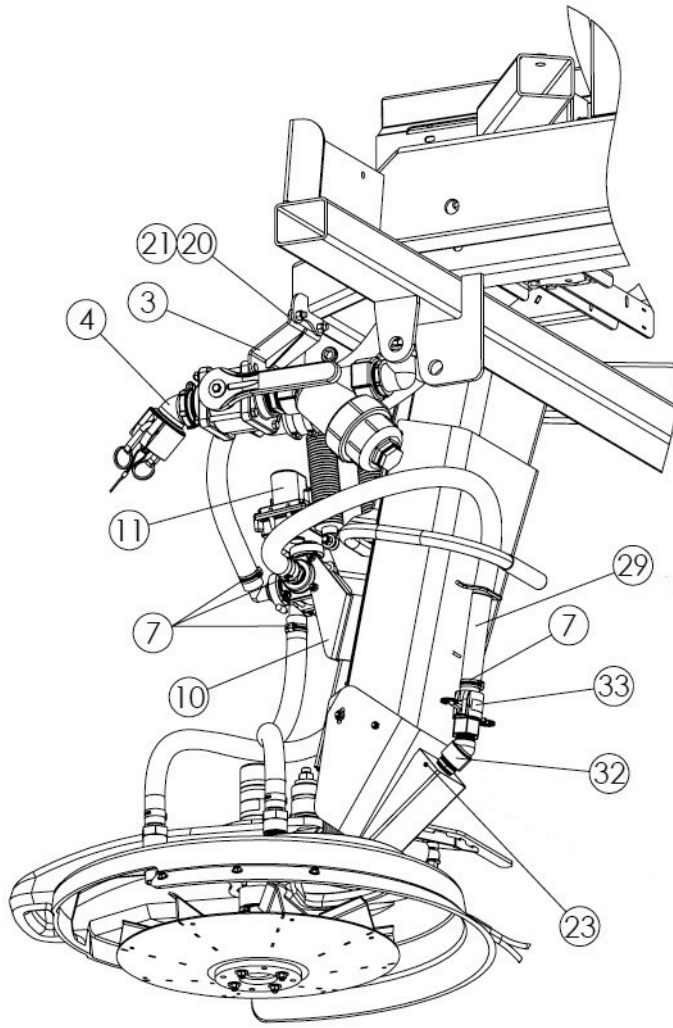

LIQUID DIFFUSER PLUMBING

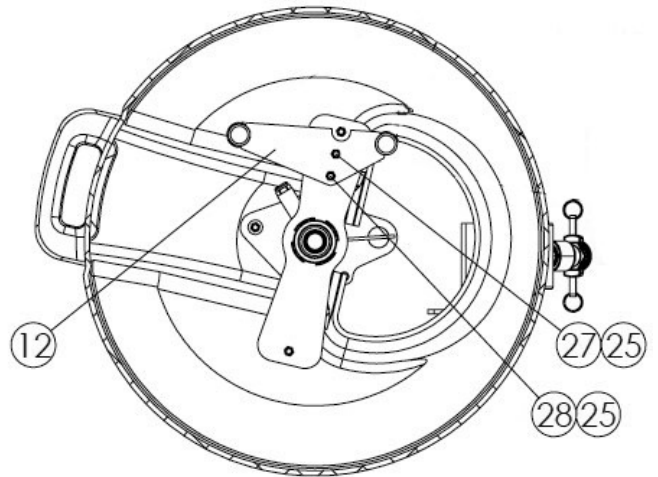

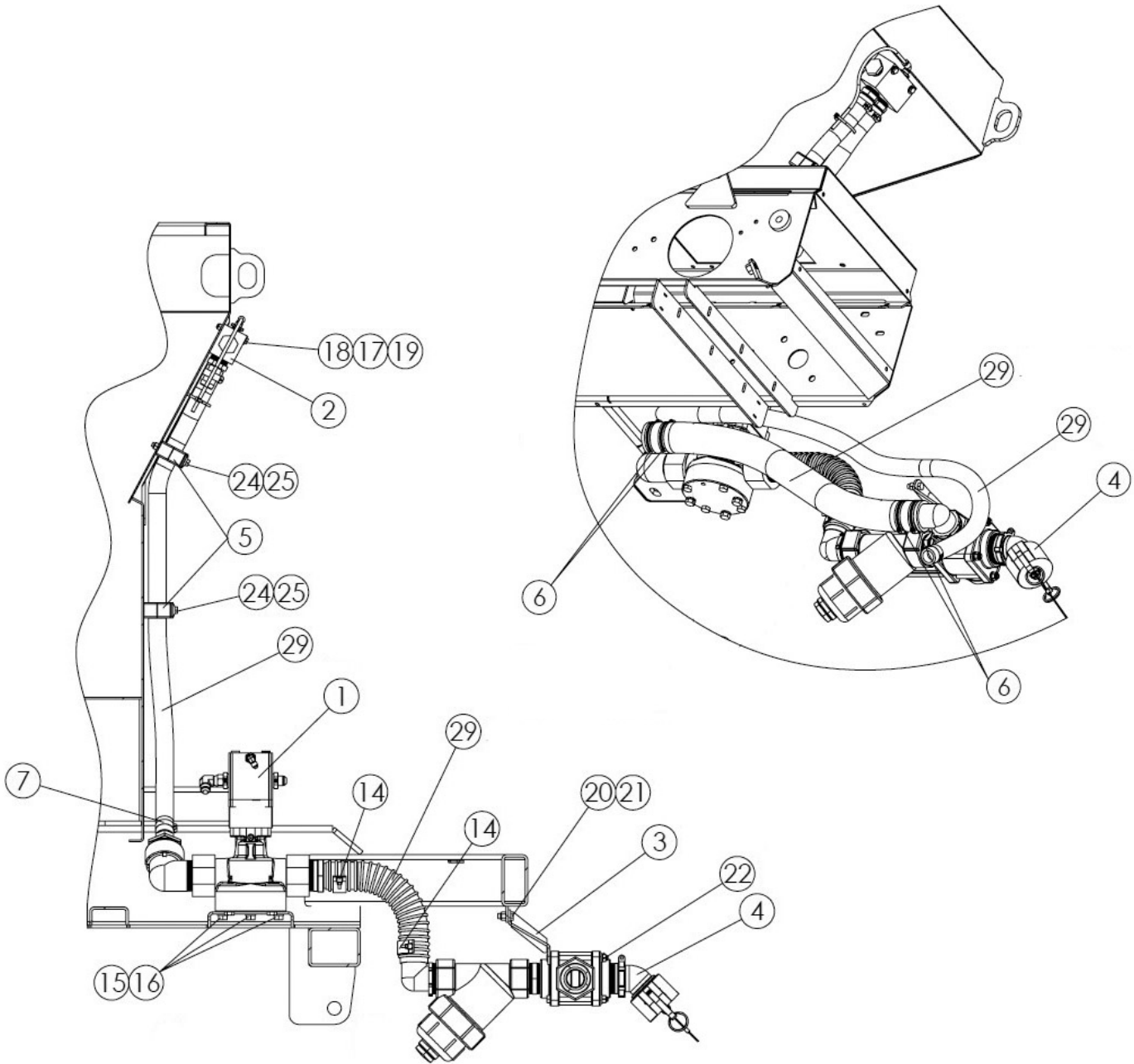

Liquid Pump System - High Volume Continued

<u>ITEM</u>	<u>PART NO.</u>	<u>DESCRIPTION</u>	<u>QTY</u>
1	309939	Pump- Assy Fitting	1
2	308011	Manifold- Assy Anti-Siphon	1
3	309935	Mount- Valve 304	1
4	309937	Valve- Assy Fill/Pump Poly	1
5	308033	Clamp- Tubing 1.33 Twin	2
6	321848	Clamp- Hose T-Bolt SS	4
7	321849	Clamp- Hose Sae 16 SS	10
8	9005-0-7761	Tube- .25od Air Brake Black	1
9	306836	Strap- Zip Tie .18 X 11 Black	1
10	309936	Bracket- Valve 304	1
11	309938	Valve- Assy 3-Way Motorized	1
12	309932	Bracket- Wldmt 304	1
13	309926	Fitting- Hose Barb 1.00 Hose	2
14	308170	Clamp- 2 Spiral Double Bolt	2
15	36421	Washer- Lock .438 SS	3
16	96921	Capscrew- M10 X 20 SS	3
17	36423	Washer- Flat .25 SS	2
18	34501	Capscrew- .25-20nc X 2.5 SS	2
19	42034	Nut- Lock .25-20nc SS	2
20	36398	Capscrew- .375-16nc X 1 SS	2
21	72054	Nut- Lock .375-16nc SS	2
22	307395	Nut- Lock Thin .375-16nc SS	2
23	56315	Screw- Self Drilling #6-20nc	2
24	96258	Capscrew- .313-18nc X 3 SS	2
25	42221	Nut- Lock .313-18nc SS	6
26	36424	Washer- Flat .313 SS	1
27	36397	Capscrew- .313-18nc X 1.25 SS	1
28	34580	Capscrew- .313-18nc X 1 SS	1
29	309945	Hose- Group High Volume	1
30	*96942	Tie- Wire Hd 29 Long	2
31	*308241	Sealant- Rtv 732	0
32	310678	Diffuser- Assy	1
33	310675	Coupling- 1 Female X 1 Hose	1

* Not Shown



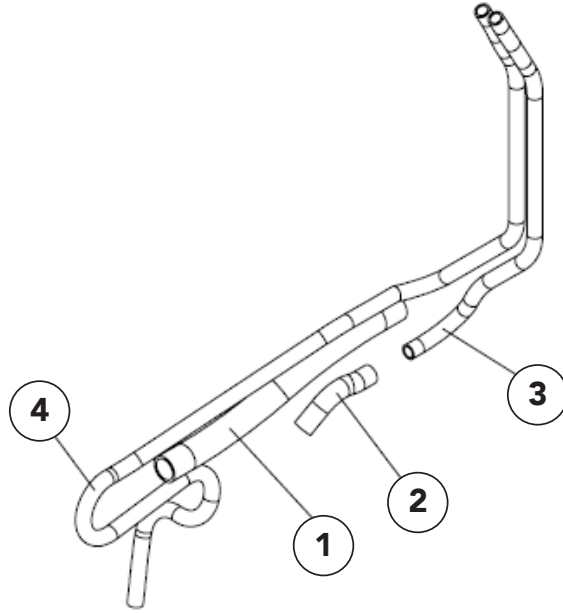

<u>ITEM</u>	<u>PART NO.</u>	<u>DESCRIPTION</u>	<u>QTY</u>
1	307905	Hose- 2" Vaccum/Transfer PVC	26 in.
2	307906	Hose- 1.25 Vaccum/Transfer PVC	9 in.
3	307907	Hose- 1" Vaccum/Transfer PVC	48 in.
4	307909	Hose- 1" EPDM Suction	120 in.

Liquid System Hose Group - High Volume

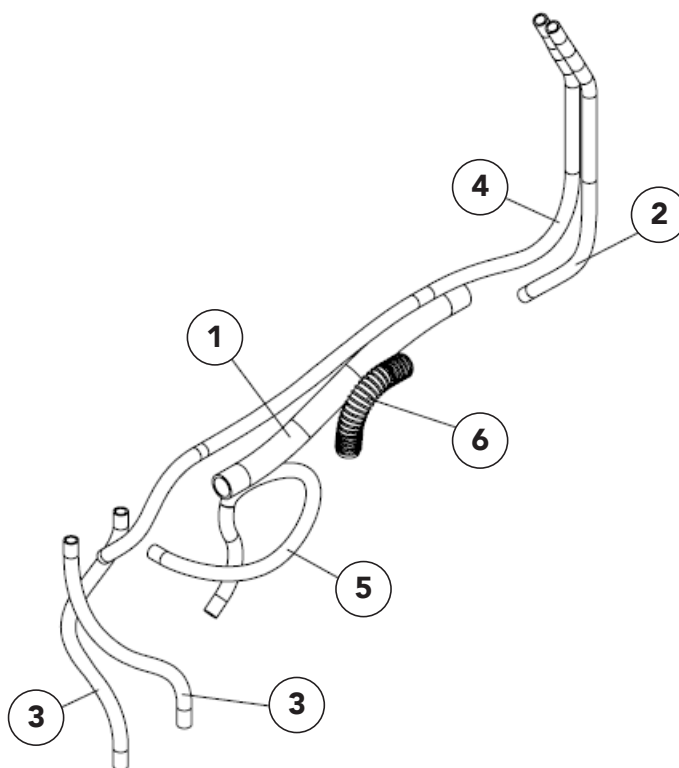

<u>ITEM</u>	<u>PART NO.</u>	<u>DESCRIPTION</u>	<u>QTY</u>
1	307905	Hose- 2" Vaccum/Transfer PVC	31 in.
2	307907	Hose- 1" Vaccum/Transfer PVC	42 in.
3	307907	Hose- 1" Vaccum/Transfer PVC	72 in.
4	307909	Hose- 1" EPDM Suction	100 in.
5	307909	Hose- 1" EPDM Suction	50 in.
6	308169	Hose- 2" PVC	12 in.

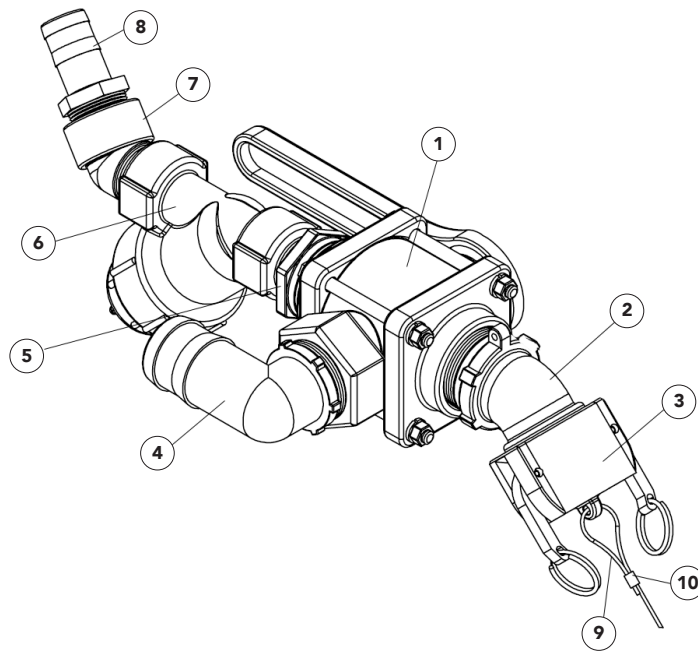

<u>ITEM</u>	<u>PART NO.</u>	<u>DESCRIPTION</u>	<u>QTY</u>
1	307911	Valve- 2" NPT 3-way poly	1
2	307912	Fitting- 2" camlock x 2" MNPT 45 deg	1
3	307913	Dust Cap- 2" camlock poly	1
4	307897	Fitting- Hose barb 90 deg 2" hose x 2" MNPT poly	1
5	307899	Fitting- Nipple reducing 2" NPT x 1.25 NPT poly	1
6	307910	Y Strainer- 1.25 NPT	1
7	308020	Fitting- Street elbow 1.25 NPT 45 deg poly	1
8	307896	Fitting- Hose barb 1.25 ose x 1.25 MNPT poly	1
9	308084	Cable- Coated	1
10	308085	Ferrule	2

Fill/Pump Valve Assy - High Volume

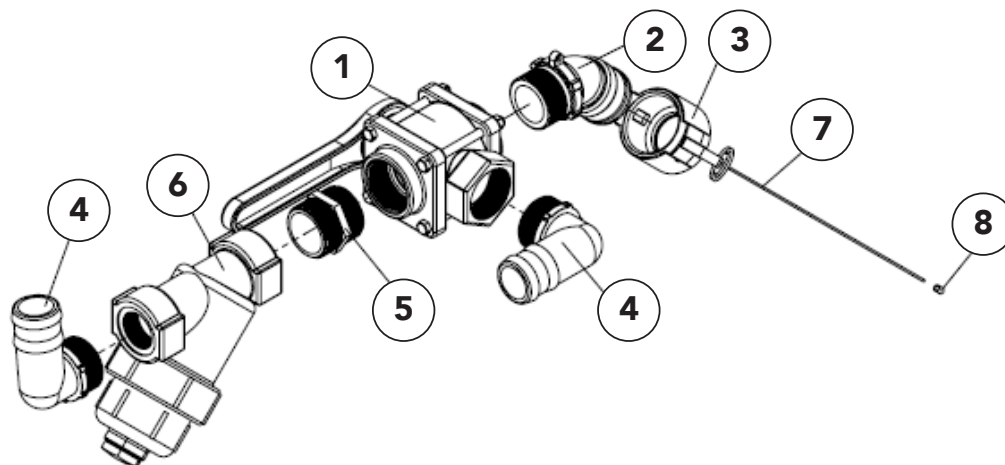

<u>ITEM</u>	<u>PART NO.</u>	<u>DESCRIPTION</u>	<u>QTY</u>
1	307911	Valve- 2" NPT 3-way poly	1
2	307912	Fitting- 2" camlock x 2" MNPT 45 deg	1
3	307913	Dust Cap- 2" camlock poly	1
4	307897	Fitting- Hose Barb 90 deg 2" hose x 2" MNPT poly	2
5	309920	Fitting- Nipple short 2.00 NPT poly	1
6	309919	Y Strainer- 2.00 NPT poly	1
7	308084	Cable- .094 x 24 coated	1
8	308085	Ferrule- .185 x .374	2



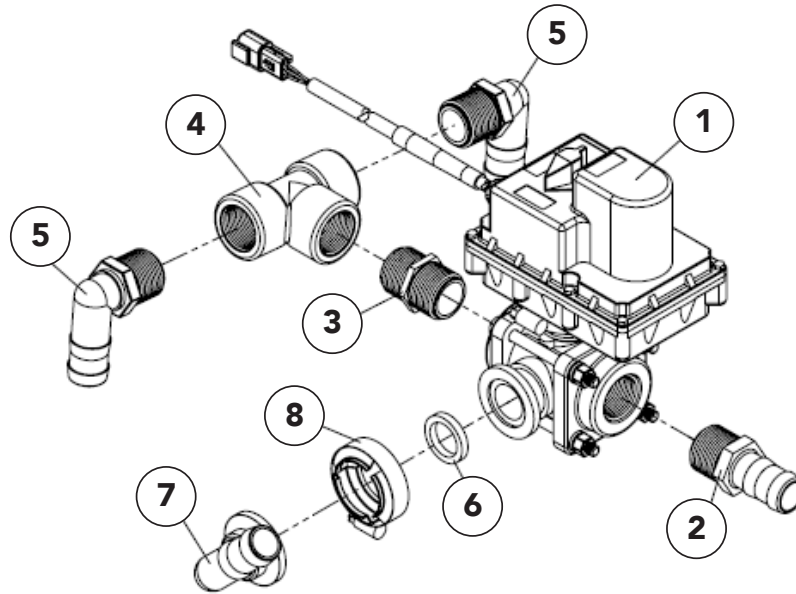

<u>ITEM</u>	<u>PART NO.</u>	<u>DESCRIPTION</u>	<u>QTY</u>
1	309918	Valve- 1" elec 3-Way with DTM04-3P	1
2	307895	Fitting- Hose Barb 1" hose x 1"MNPT poly	1
3	309923	Fitting- Nipple Short 1.00 NPT poly	1
4	309924	Fitting- Tee Poly 1.00 NPT poly	1
5	309925	Fitting- Hose Barb 90 deg 1.00 hose x 1.00 NPT poly	2
6	309929	Gasket- 1.00 flange EPDM	1
7	309927	Fitting- Hose Barb 90 deg 1.00 hose x 1.00 flange poly	1
8	309928	Clamp- Flange 1.00	1

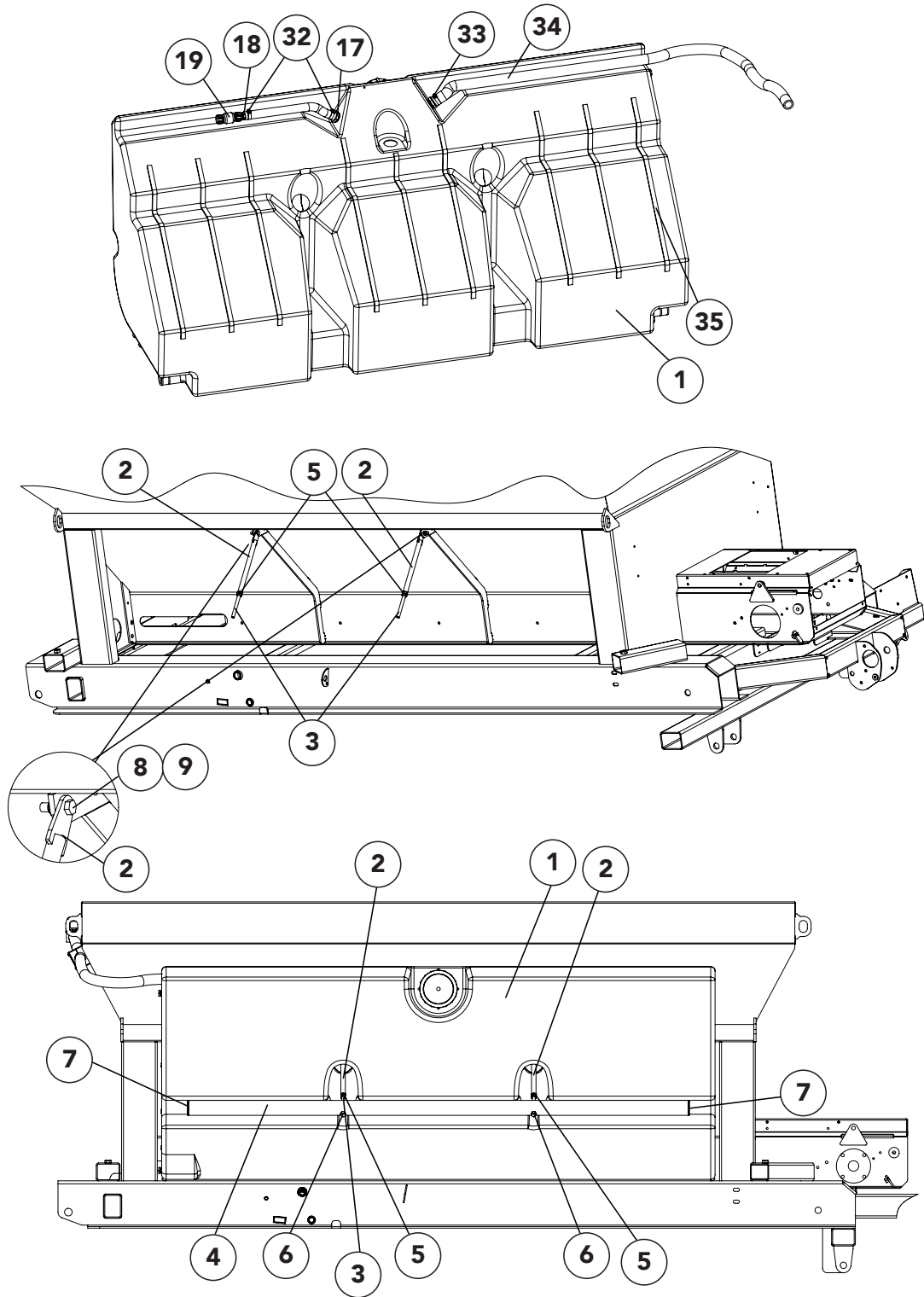

Liquid Tank Group Continued

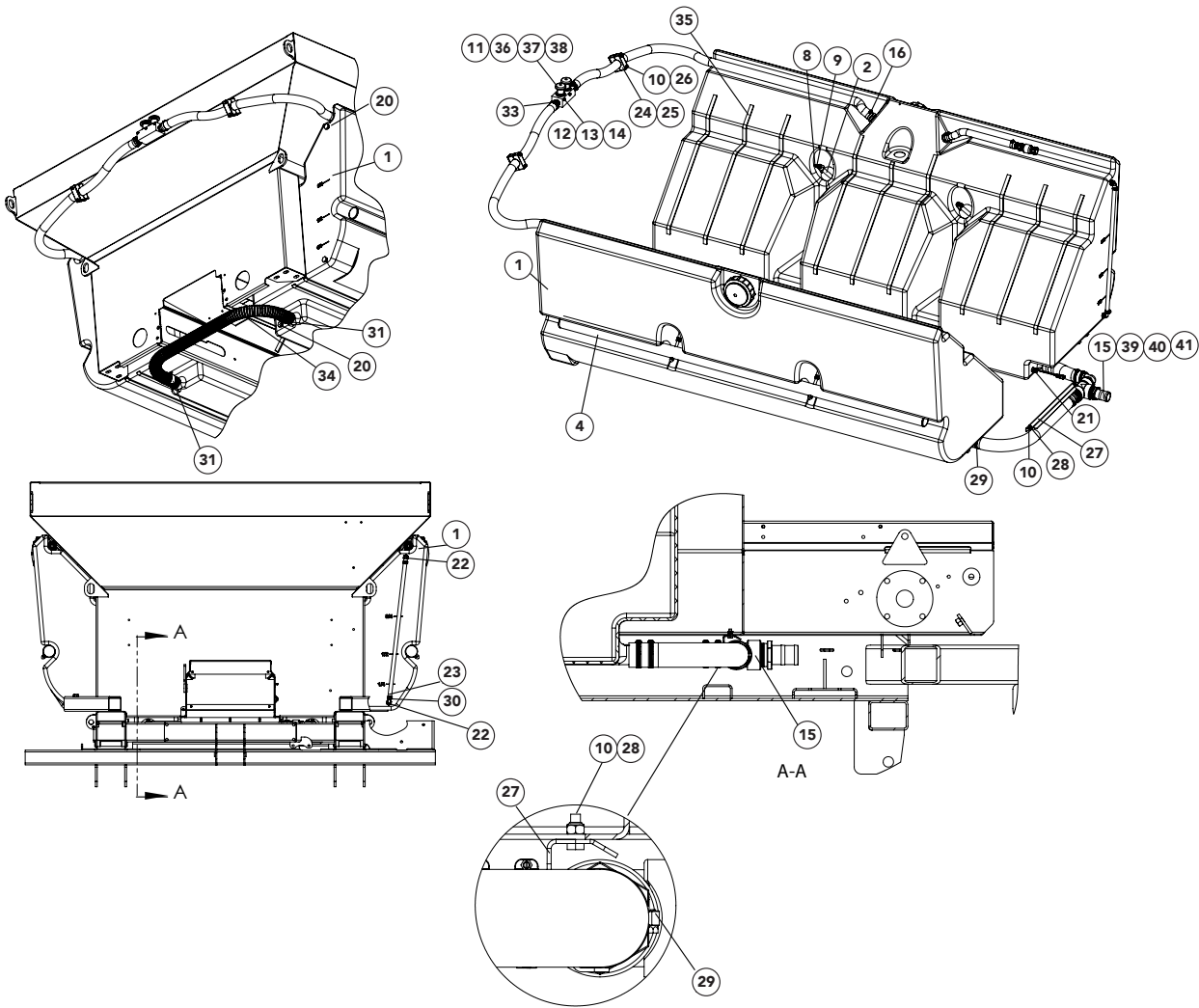

<u>ITEM</u>	<u>PART NO.</u>	<u>DESCRIPTION</u>	<u>QTY</u>
1	307937	Tank- 232 Gal 10'	2
	307938	Tank- 292 Gal 12'	2
	307939	Tank- 350 Gal 14'	2
2	308005	Wldmt- Turn Buckle 304	AR
3	308008	Rod- Threaded .5-13NC x 6 SS	AR
4	308009	Tube- Tank Mount Galvanized (10')	2
	308316	Tube- Tank Mount Galvanized (12')	2
	308317	Tube- Tank Mount Galvanized (14')	2
5	36416	Nut- Hex .5-13NC SS	AR
6	308010	Nut- Acorn .5-13NC SS	AR
	312454	Washer- Formed	AR



Liquid Tank Group Continued

<u>ITEM</u>	<u>PART NO.</u>	<u>DESCRIPTION</u>	<u>QTY</u>
7	308024	Plug- Poly 2.5	4
8	36399	Cap Screw- .375-16NC x 1.25 SS	AR
9	72054	Nut- Lock .375-16NC SS	AR
10	42034	Nut- Lock .25-20NC SS	6
11	308014	Vent- Assy Tank poly, includes items 36-38	1
12	171052	Washer- Flat #10 SS	3
13	44398	Screw- Round Head #10-24NC x 3 SS	3
14	56355	Nut- Lock #10-24NC SS	3
15	308016	Tee- Assy 2" Poly, includes items 39-41	1
16	307896	Fitting- Hose Barb 1.25 hose x 1.25 MNPT poly	2
17	308021	Fitting- Hose Barb 1" hose x 1.25 MNPT poly	2
18	308022	Fitting- Hose Barb 1" hose x .75 MNPT poly	2
19	307922	Valve- Check 5 PSI .75 FNPT PVC	2
20	307902	Fitting- Plug .5 NPT Hex head poly	3
21	308183	Float Switch- .5 MNPT side mtg poly with DT04-2P	1
22	307898	Fitting- Hose barb 90 deg .t hose x .t MNPT poly	2
23	308023	Float- Ball poly	1
24	308165	Clamp Pair- 1.75" Tube	2
25	308164	Plate- Cover Clamp 1.75 OD Tube Hys SS	2
26	56396	Capscrew- .25-20NC x 3.25 SS	4
27	308051	Bracket- Hose 304	1
28	36393	Capscrew- .25-20NC x .75 SS	2
29	321848	Clamp- Hose T-Bolt SS	8
30	308027	Clamp- Hose SAE 8 SS	2
31	321799	Clamp- Hose SAE 24 SS	4
32	321849	Clamp- Hose SAE 16 SS	4
33	308170	Clamp- 2.00 Spiral Double bolt	2
34	308245	Group- Liquid Hose 10'	1
	308318	Group- Liquid Hose 12'	1
	308319	Group- Liquid Hose 14'	1
35	84280	Strip- Rubber	AR
36	307971	Manfold- Vent	1
37	307904	Vent- Labyrinth Air poly	2
38	308015	Fitting- Hose barb 1.25 x hose x 1" MNPT poly	2
39	308017	Fitting- TEE 2" FNPT poly	1
40	308018	Fitting- Hose barb 2" Hose x 2" MNPT poly	2
41	307897	Fitting- Hose barb 90 deg 2" hose x 2" MNPT poly	1



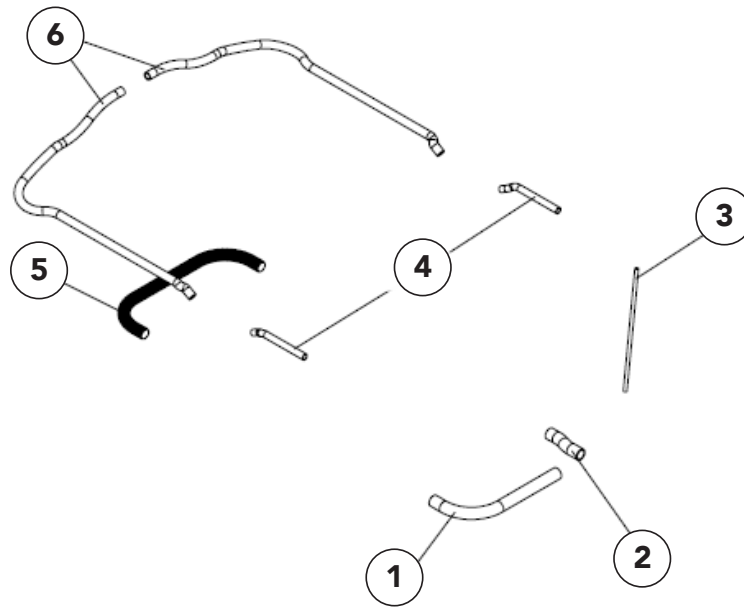

<u>ITEM</u>	<u>PART NO.</u>	<u>DESCRIPTION</u>	<u>QTY</u>
1	307905	Hose- 2" Vaccum/Transfer PVC	31.5 in.
2	307905	Hose- 2" Vaccum/Transfer PVC	9.8 in.
3	307908	Hose- .5" Clear PVC sight	29 in.
4	307907	Hose- 1" Vaccum/Transfer PVC	32.6 in.
5	308169	Hose- 2" Vaccum/Transfer PVC	48 in.
6	307906	Hose- 1.25" Vaccum/Transfer PVC (10' unit)	170 in.
	307906	Hose- 1.25" Vaccum/Transfer PVC (12' unit)	194 in.
	307906	Hose- 1.25" Vaccum/Transfer PVC (14' unit)	218 in.

Metering Gate Assy

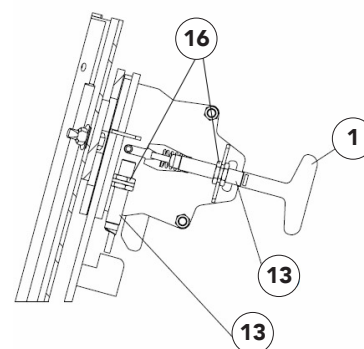
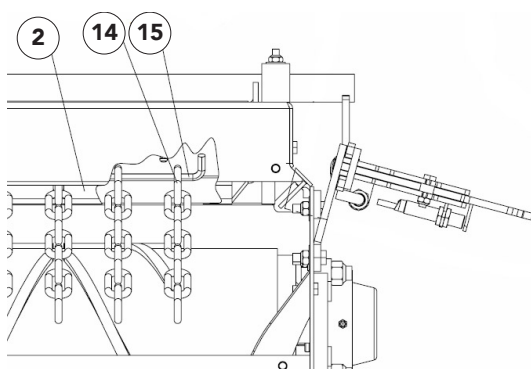
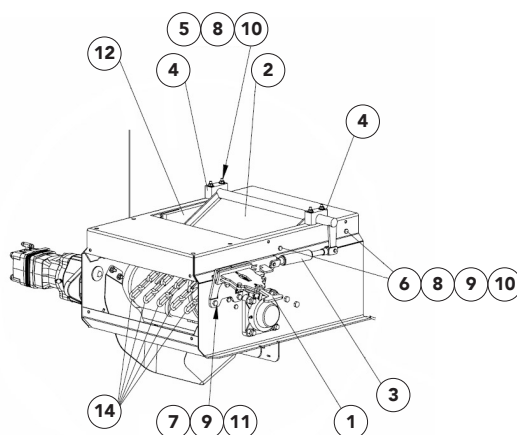

ITEM	PART NO.	DESCRIPTION	QTY
1	308094	Mechanism- Assy metering gate 304 * parts list on other page	1
2	308108	Gate- Wldmt Metering 304	1
3	308113	Spring- Gas	1
4	308116	Pivot- Bearing	2
5	308112	Cap Screw- .25-20NC x 2 SS	4
6	36395	Cap Screw- .25-20NC x 1 SS	4
7	34580	Cap Screw- .313-18NC x 1 SS	3
8	36423	Washer- Flat .25 SS	8
9	36424	Washer- Flat .313 SS	3
10	42034	Nut- Lock .25-20NC SS	8
11	42221	Nut- Lock .313-18NC SS	3
12	310670	Guide- Metering Gate RH	1
13	308175	Sensor- 12mm	2
14	308114	Chain- Straight link coil 5/0 9LK	5
15	308115	Bar- Retainer 304	1
16	308236	Washer- Star Internal	4
17	310671	Guide- Metering Gate LH	1



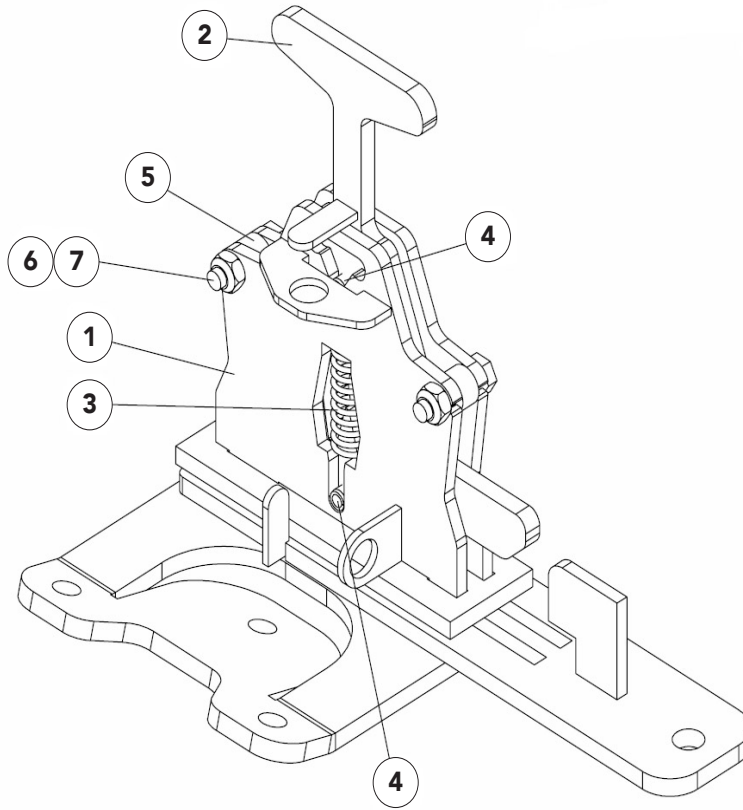

<u>ITEM</u>	<u>PART NO.</u>	<u>DESCRIPTION</u>	<u>QTY</u>
1	308098	Plate- Wldmt metering gate mech 304	1
2	308095	Bolt- Wldmt metering gate 304	1
3	308081	Spring SS	1
4	308082	Pin- Roll . 25 x .625 SS	2
5	308107	Spacer- .281 ID x .290 304	2
6	40750	Cap Screw- .25-20NC x 1.25 SS	2
7	42034	Nut- Lock .25-20NC SS	2

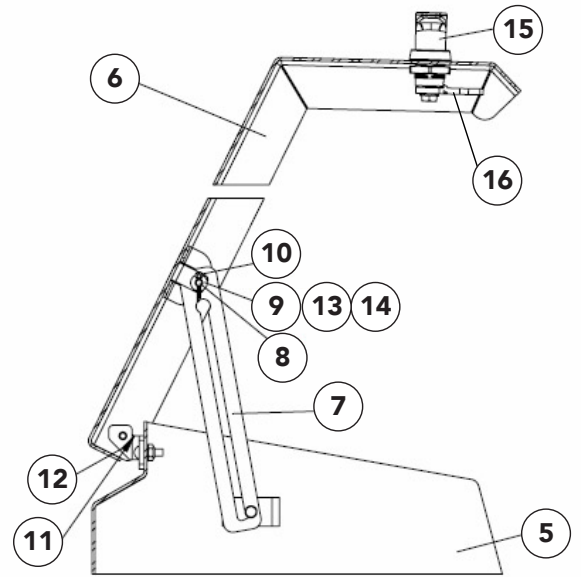
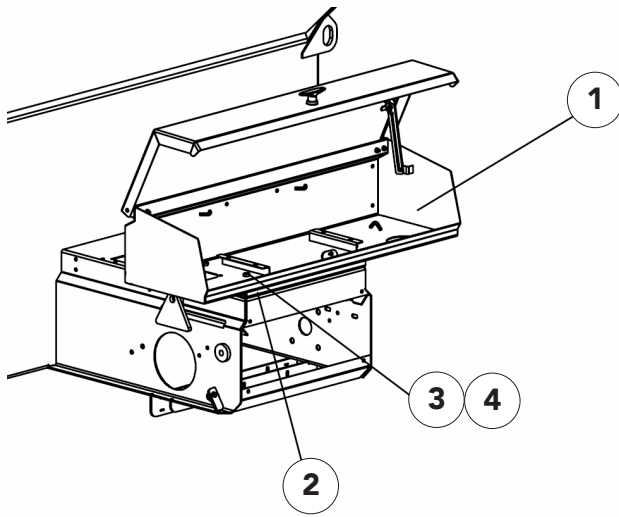

<u>ITEM</u>	<u>PART NO.</u>	<u>DESCRIPTION</u>	<u>QTY</u>
1	308130	Enclosure- Assembly includes items 5-17	1
2	308171	Mount- Enclosure 304	2
3	36293	Cap Screw- .375-16NC x .75 SS	8
4	72054	Nut- Lock .375-16NC SS	8
5	308131	Enclosure- Wldmt base 304	1
6	308138	Enclosure- Wldmt lid 304	1
7	308142	Stop- Lid 304	1
8	308137	Pin- Clevis .188 x .625 SS	1
9	171052	Washer- Flat #10 SS	5
10	76822	Pin- Cotter .094 x .5 SS	1
11	308141-AA	Hinge- LH 304	1
12	308141-AB	Hinge- RH 304	1
13	44453	Screw- Round head #10-24NC x .625 SS	4
14	56355	Nut- Lock #10-24NC SS	4
15	308144	Latch- Cam E5	1
16	308145	Hook- Cam E5	1
17	*308120	Seal- Strip	8.33'

*-- not shown

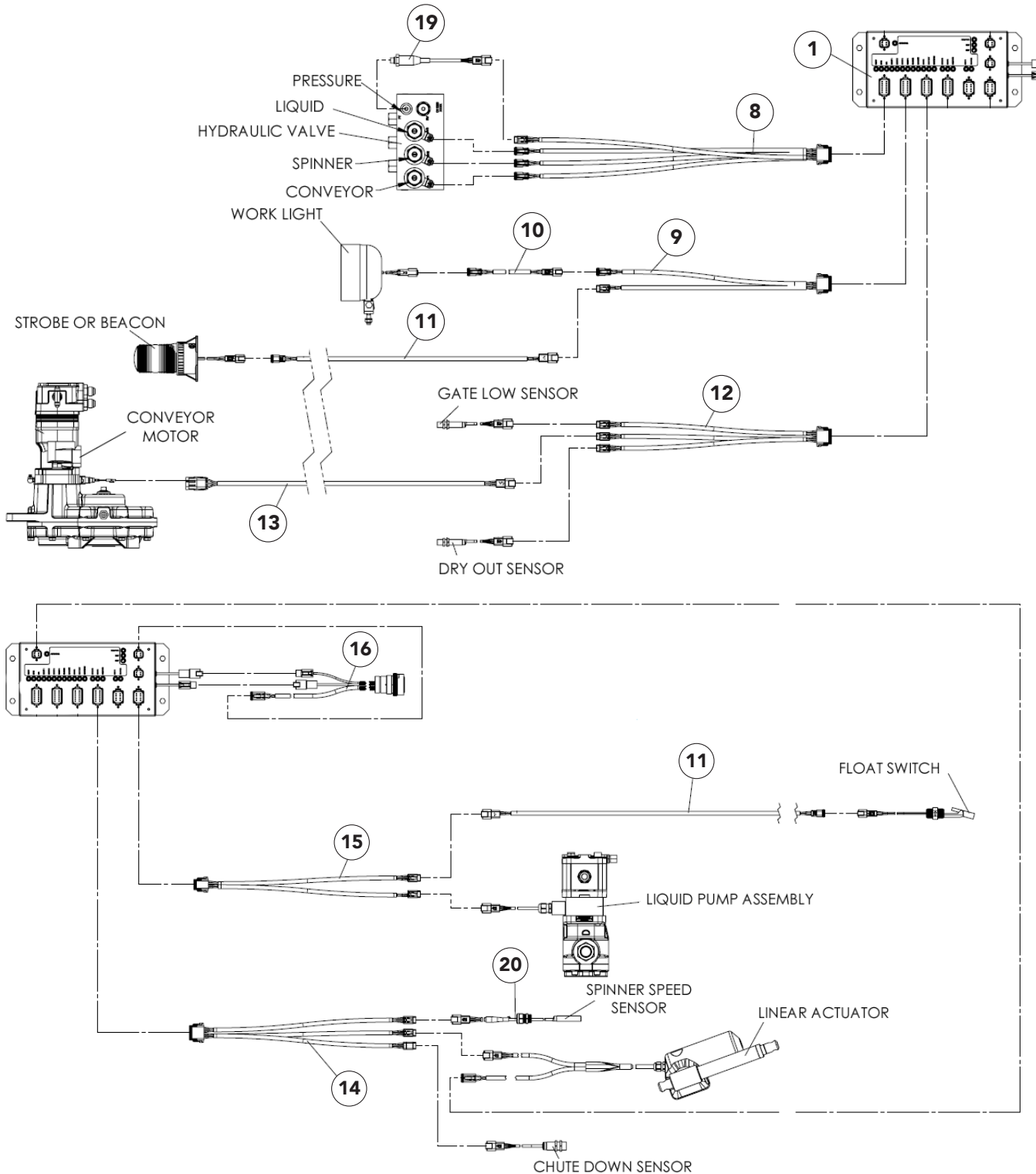

Controller Continued

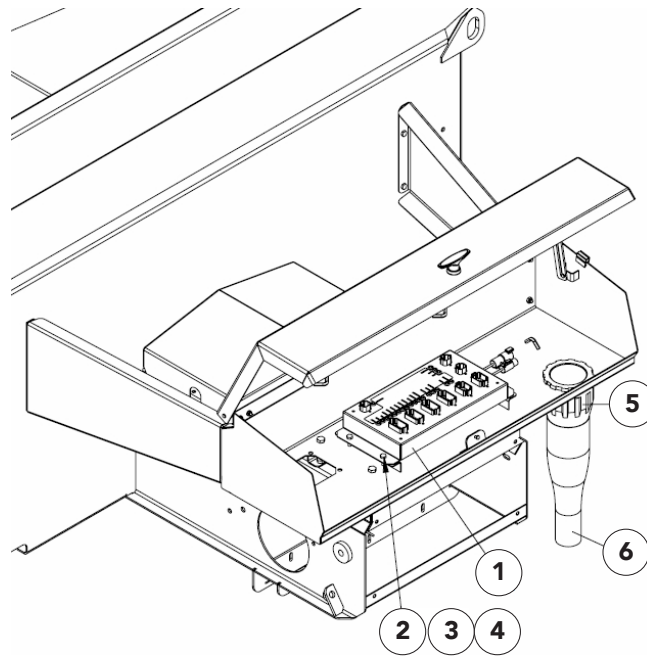

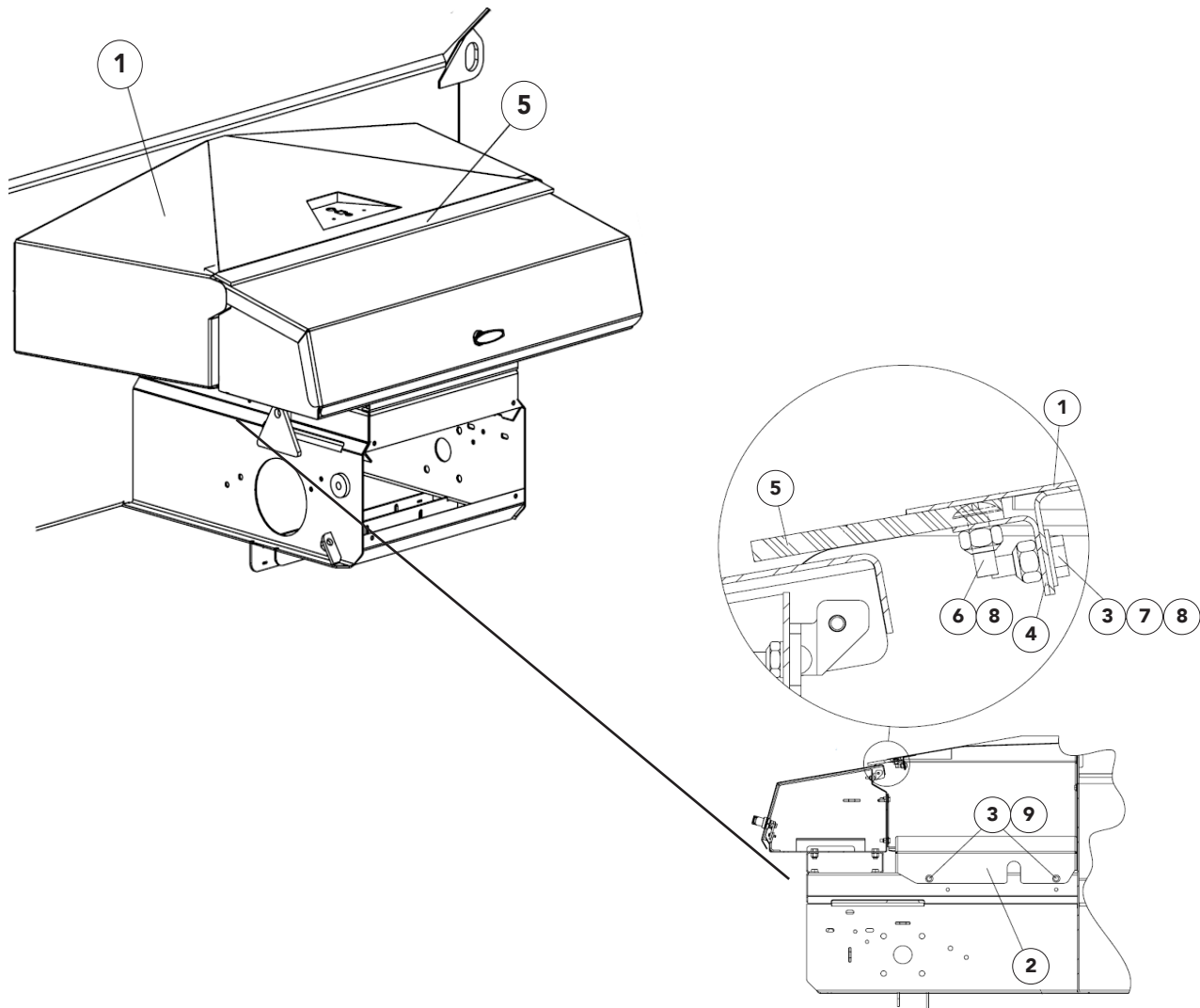

ITEM	PART NO.	DESCRIPTION	QTY
1	308299	Cover- Wldmt Rear 304	1
2	308117	Cover- Metering Gate 304	1
3	36423	Washer- Flat .25 SS	16
4	308304	Angle 304	1
5	53251	Belt- .25 x 3 skirtboard	3 ft.
6	32446	Screw- Truss Head .25-20NC x .75 SS	7
7	36393	Cap Screw- .25-20NC x .75 SS	12
8	42034	Nut- lock .25-20NC SS	19
9	58799	Cap Screw- .25-20NC x .5 SS	4

This page is intentionally left blank.

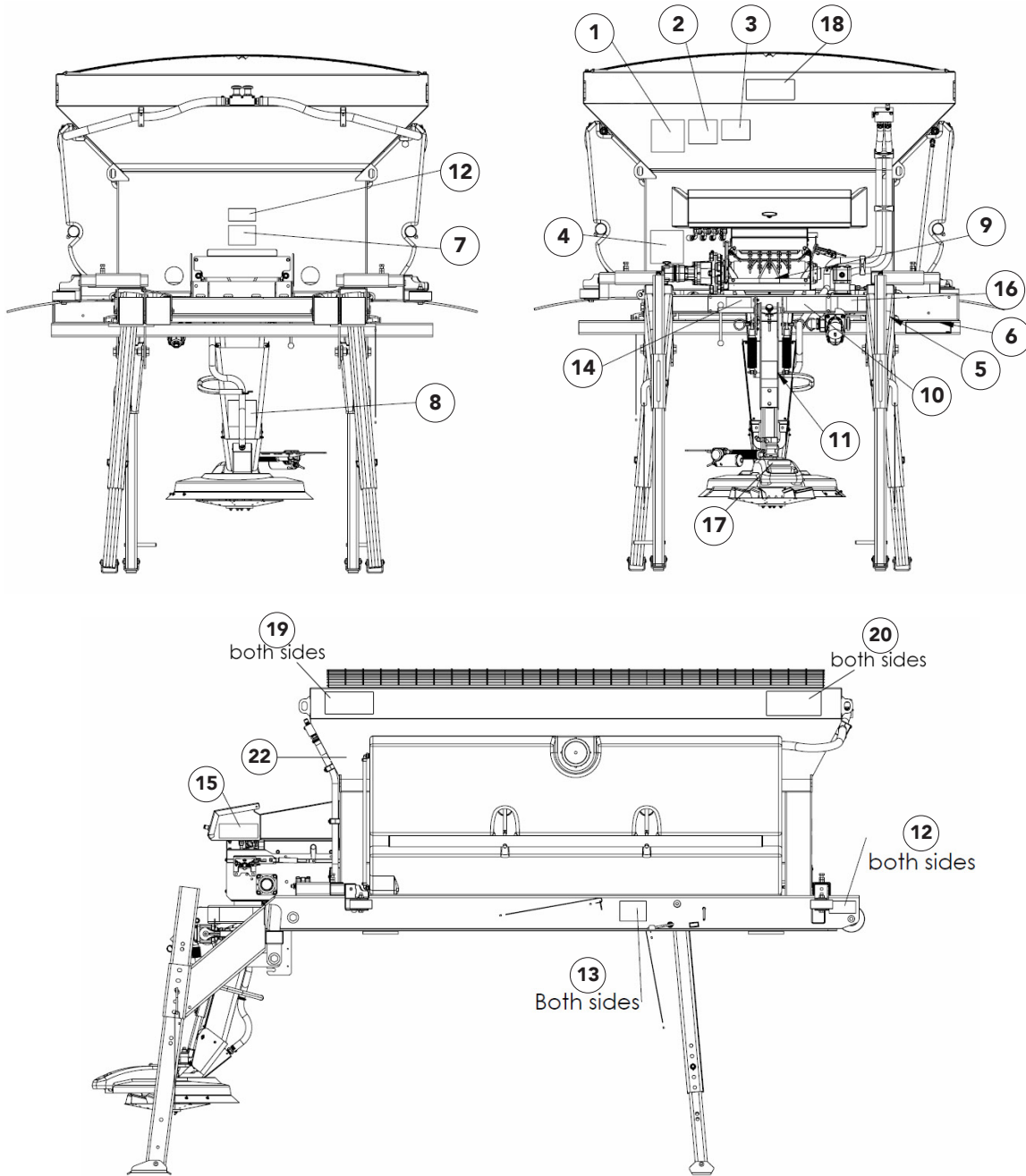

Decals Continued

<u>ITEM</u>	<u>PART NO.</u>	<u>DESCRIPTION</u>	<u>QTY</u>
1	150034	Decal- Caution Operation & Maint	1
2	364	Decal- Danger Moving Part	1
3	321	Decal- Caution Hazardous Material	1
4	39138	Decal- Warning High Pressure Fluid	1
5	39017	Decal- No Step	2
6	305274	Decal- Falling Hazard	1
7	55631	Decal- Warning Moving Part Hazard	1
8	71807	Decal- Warning Falling Spinner Hazard	1
9	308191	Decal- Guard is Missing	1
10	308192	Decal- Flying Material	1
11	308193	Decal- Falling Hazard	1
12	308194	Decal- Crushing Hazard	3
13	308195	Decal- Lock Leg (units equipped with storage legs)	2
14	308196	Decal- Read Manual	1
15	308197	Decal- Metering Gate Positions	1
16	308198	Decal- Liquid Valve Positions	1
17	308199	Decal- No Step	1
18	308306	Decal- HiWay/Xzalt	1
19	39870	Decal- HiWay Large	2
20	308305	Decal- Xzalt	2
21	*39200	Decal- Warning Slipping Hazard (Fenders)	2
22	315865	Decal - Warning, Prop 65	1

* – Not Shown

NOTE: See "Safety Decals" in Safety section of operator's manual for details.



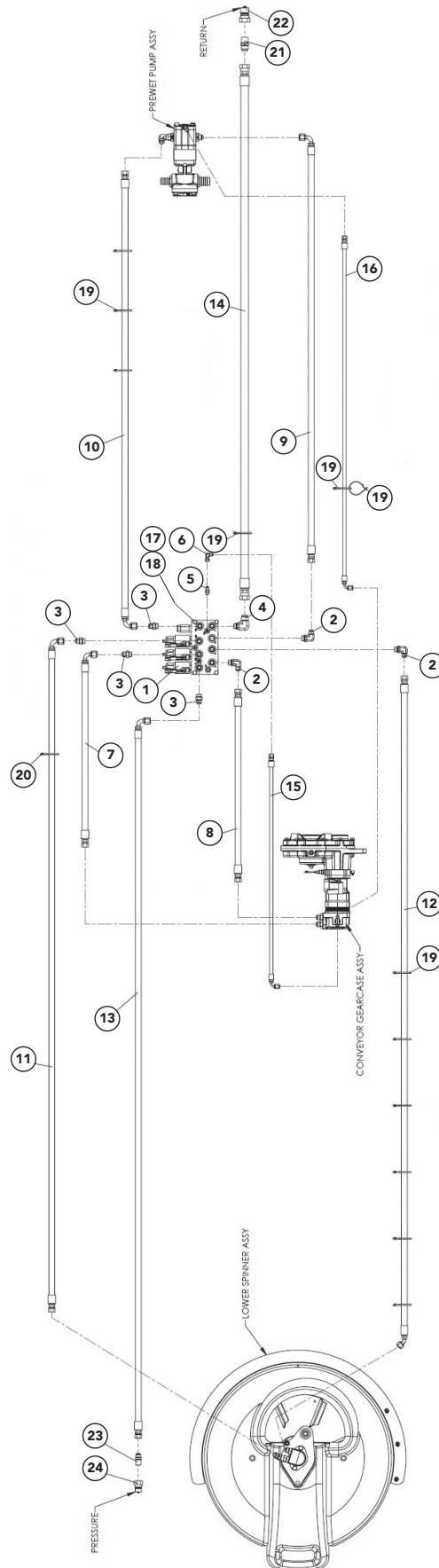

Hydraulics Continued

<u>ITEM</u>	<u>PART NO.</u>	<u>DESCRIPTION</u>	<u>QTY</u>
1	307941	Valve - Hydraulics	1
2	34822	Fitting - 8-8 070220	3
3	29770	Fitting - 8-8 070120	4
4	308211	Fitting - 12-8 070220	1
5	29849	Fitting - 4-4 070120	1
6	34868	Fitting - 4-4 070221	1
7	308200	Hose - Assy .5 X 29 100r2	1
8	308201	Hose - Assy .5 X 29 100r2	1
9	308202	Hose - Assy .5 X 64 100r2	1
10	308203	Hose - Assy .5 X 68.5 100r2	1
11	308204	Hose - Assy .5 X 101 100r2	1
12	308205	Hose - Assy .5 X 101 100r2	1
13	308206	Hose - Assy .5 X 108 100r2	1
14	308207	Hose - Assy .75 X 108 100r2	1
15	308208	Hose - Assy .25 X 35 100r1	1
16	308209	Hose - Assy .25 X 53 100r1	1
17	308212	Capscrew - .313-18nc X .5 Ss	4
18	36419	Washer - Lock .313 Ss	4
19	99674	Strap - Zip Tie 8 Black	12
20	306836	Strap - Zip Tie .18 X 11 Black	1
21	29752	Fitting - 12-12 070102	1
22	39905	Disconnect - Quick .75 Male	1
23	29767	Fitting - 8-8 070102	1
24	40008	Disconnect - Quick Male Half	1
25	*96942	Tie - Wire Hd 29 Long	1



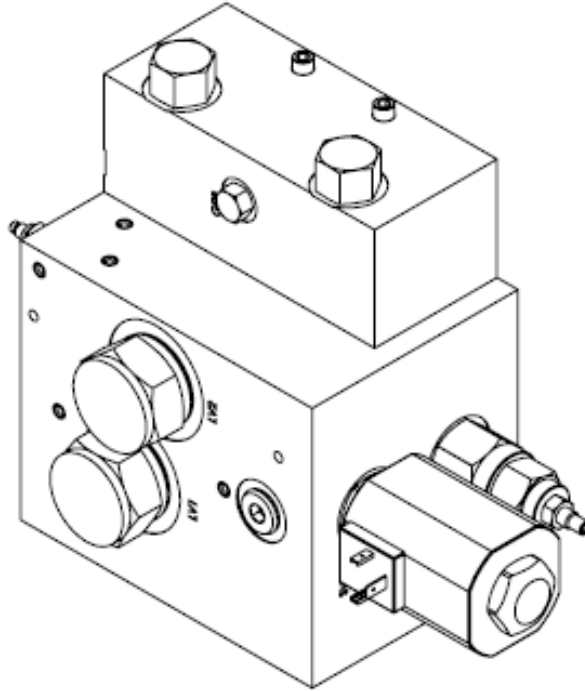

<u>ITEM</u>	<u>PART NO.</u>	<u>DESCRIPTION</u>	<u>QTY</u>
1	308366	Valve- Hydraulic Flow Control	1