



EA2
Operator's/Parts Manual

UNIT SERIAL NO. _____

MANUAL NUMBER: 319235-B

EFFECTIVE 06/2023



1330 76TH AVE SW
CEDAR RAPIDS, IA 52404-7052
PHONE (800) 363-1771 | FAX (319) 286-3350
www.newleader.com

Copyright 2021 New Leader Manufacturing

Table of Contents	2
Interactive Features	5
Preface	7
Safety	8
Important Safety Information	8
Safety Alert Symbols	8
General Safety Rules	9
Safety Decals.....	19
Safety Decal Maintenance.....	19
Safety Decal Installation	19
Installation Instructions	27
Hydraulic Requirements.....	27
Mounting Requirements.....	28
Truck Chassis Installation	28
Lifting the Spreader	28
Securing to Frame.....	29
Dump Body Installation	30
Spreader Preparation.....	30
Loading	31
Securing Spreader.....	33
Removal From Dump Body	34
Hydraulic Hose Installation Guide	35
Ladder – Side.....	36
Ladder – Rear	37
Cab Shield.....	38
Fenders	39
Operations.....	41
Dimensions & Capacities	42
Initial Startup.....	46
Spinner.....	47
Storage Position	47
Spreading Position	48
Drop Point.....	48
Setting Spinner Height	49
Filling Hopper.....	51
Liquid System	51
Filling Liquid Tanks	51
Tarp.....	51
Liquid Valve.....	52
Filling Liquid Tanks.....	52
Post-Spread	54
Spread Rate Limits.....	55
Typical Liquid Densities	56
Maintenance	59
Preventative Maintenance Pays!	59
Hydraulic System.....	59
Hydraulic Hose	60
Storage and Handling.....	60
Electrical System.....	61
Liquid System	61
Liquid Pump.....	61
Suction Strainer	61



Table of Contents Continued

Auger Gearcase..... 62

Sensors..... 63

 Spinner Speed Sensor 63

 Spinner Up Sensor..... 64

Lubrication of Bearings..... 65

Fasteners..... 65

Clean-Up..... 65

Lubricant & Hydraulic Oil Specifications 66

 Hydraulic System 66

 Gearcase Lubricant 66

 Grease Gun Lubricant..... 66

Lubrication & Maintenance Chart 67

 Lubrication Points..... 68

Standard Torques..... 69

Table of Contents Continued

Parts	71
Body.....	72
Screen.....	72
Rear Ladder.....	73
Side Ladder.....	74
Side Ladder 12" Ext.....	76
Tarp.....	78
Spill Shield	84
Cab Shield.....	86
Truck Chassis Mount.....	88
Subframe.....	88
Mount Kit	89
Fenders	91
Dump Body Mount.....	92
Subframe.....	92
Mount Kit	96
Inverted V-Assembly.....	98
Spinner	100
Spinner Pivot.....	100
Spinner Assembly.....	102
Lower Spinner Assembly	106
Chute Assembly	110
Spinner Disc Assembly	113
Liquid System.....	114
Liquid - Assy Prewet 25 GPM	114
Plug Group.....	116
Liquid - Assy Prewet 50 GPM	118
3-Way Motorized Valve Assembly.....	120
Hose Group 25 GPM.....	121
Hose Group 50 GPM.....	122
Pump Assembly 25 GPM	123
Pump Assembly 50 GPM	124
Elbow Assembly	126
Strainer Valve Assembly.....	127
Fill/Pump Valve Assembly.....	128
Tee Assembly #1.....	129
Tee Assembly #2.....	130
Diffuser Assembly.....	131
Liquid Tank Group.....	132
Liquid Tank Hose Group	137
Liquid - Assy Anti-ice	138
Liquid - Assy Anti-ice Spraybar	143
Valve - Assy 3-Way Poly.....	145
Valve - Assy Electric Poly.....	147
Hose Group	149
Auger Drive Assembly.....	150
Auger Drive Assembly Installation	154
Decals	156



NOTE:

This manual incorporates several interactive features to provide supplemental information and ease of navigation. The information below is to aid in the identification and use of these features.

Hyperlinks

Hyperlinks provide direct access to a specific destination when clicked. The entire Table of Contents of this manual is hyperlinked to provide quick access to all sections of this manual when viewing the electronic version.

Hyperlinks within the content are denoted by **blue, bold underlined text**. Electronic format viewers can click these links for direct access to New Leader online features. Internet access is required.



Insert Current HI-WAY Warranty

PLEASE ! ALWAYS THINK SAFETY FIRST !!

The purpose of this manual is to familiarize the person (or persons) using this unit with the information necessary to properly install, operate, and maintain this system. The safety instructions indicated by the safety alert symbol in the following pages supersede the general safety rules. These instructions cannot replace the following: the fundamental knowledge that must be possessed by the installer or operator, the knowledge of a qualified person, or the clear thinking necessary to install and operate this equipment. Since the life of any machine depends largely upon the care it is given, we suggest that this manual be read thoroughly and referred to frequently. If for any reason you do not understand the instructions, please call your authorized dealer or our Product Sales and Support Department at 1-888-363-8006.

It has been our experience that by following these installation instructions, and by observing the operation of the spreader, you will have sufficient understanding of the machine enabling you to troubleshoot and correct all normal problems that you may encounter. Again, we urge you to call your authorized dealer or our Product Sales and Support Department if you find the unit is not operating properly, or if you are having trouble with repairs, installation, or removal of this unit.

We urge you to protect your investment by using genuine NLM parts and our authorized dealers for all work other than routine care and adjustments.

New Leader Manufacturing reserves the right to make alterations or modifications to this equipment at any time. The manufacturer shall not be obligated to make such changes to machines already in the field.

This Safety Section should be read thoroughly and referred to frequently.

ACCIDENTS HURT !!!

ACCIDENTS COST !!!

ACCIDENTS CAN BE AVOIDED !!!

Important Safety Information

▲WARNING

Before using this equipment, read, understand and follow all instructions in the Operator's Manual provided with this equipment. If the user and/or assistants cannot read or understand the warnings and instructions, the employer of the user and/or assistants must provide adequate and necessary training to ensure proper operation and compliance with all safety procedures pertaining to this equipment. If Operator's Manual has been lost, visit www.newleader.com or call your authorized dealer or our Product Sales & Support Department at (800) 363-1771 for replacements. Serious injury or death can result from the failure to read, understand, and follow instructions provided in this manual.

Figure 1.1 - The need for safety cannot be stressed strongly enough in this manual. At New Leader Manufacturing, we urge you to make safety your top priority when operating any equipment. We firmly advise that anyone allowed to operate this machine carefully read, learn and understand all messages and information in this manual and on machine's safety decals before operating machine, as well as familiarize themselves with the location and function of all machine controls.

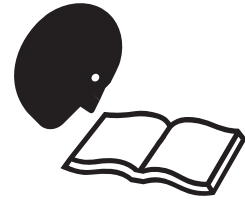

Figure 1.1

The following guidelines are intended to cover general usage and to assist you in avoiding accidents. There will be times when you will run into situations that are not covered in this section. At those times the best standard to use is common sense. If, at any time, you have a question concerning these guidelines, please call your authorized dealer or our Product Sales & Support Department at (800) 363-1771.

Safety Alert Symbols



Take note! This safety alert symbol found throughout this manual is used to call your attention to instructions involving your personal safety and that of others. Failure to follow these instructions can result in injury or death.

In this manual and on the safety signs placed on the unit, the words "DANGER," "WARNING," "CAUTION," and "NOTICE" are used to indicate the following:



DANGER indicates a hazardous situation which, if not avoided, will result in death or serious injury.



WARNING indicates a hazardous situation which, if not avoided, could result in death or serious injury.



CAUTION indicates a hazardous situation which, if not avoided, could result in minor or moderate injury.



NOTICE is used to address practices not related to physical injury.

NOTE:

Provides additional information to simplify a procedure or clarify a process.

General Safety Rules

Operations

PREPARE FOR EMERGENCIES

Figure 1.2 - Be prepared if a fire starts. Keep a fully charged fire extinguisher and first aid kit in accessible place on the vehicle at all times.

Fire extinguisher must be Type ABC or Type BC.

Keep emergency numbers for doctors, ambulance service, hospital and fire department available at all times.

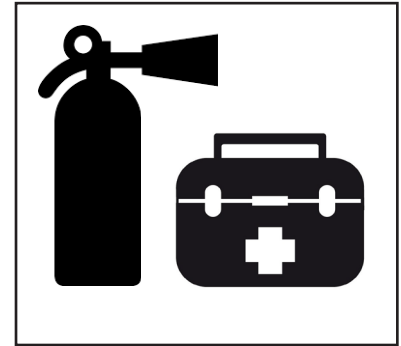

Figure 1.2

INSPECT HARDWARE BEFORE USE

Figure 1.3 - Inspect all bolts, screws, fasteners, keys, chain drives, body mounts and other attachments periodically. Immediately replace any missing or damaged parts with NLM specified parts.

Inspect spinner fins, spinner frame mounting and spinner fin hardware daily. Look for missing or loose fasteners, wear and cracks. Replace immediately with NLM specified parts.

Tighten all bolts, nuts and screws to specified torques. Refer to "Standard Torques" in Maintenance section of this manual.

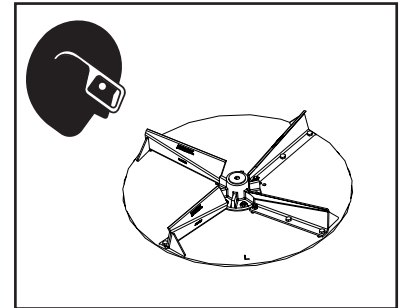

Figure 1.3

HANDLE FLAMMABLE MATERIALS SAFELY

Figure 1.4 - Handle fuel and hydraulic oil with care. They are highly flammable.

Exposure to toxic fluids or fumes may occur during the normal operation of this system. Before attempting to fill, use, or service this system, read Safety Data Sheets (SDS) to know the specific hazards of the fluids you are using. Always use proper Personal Protective Equipment when attempting to fill, use, or service this system.

Always stop engine before refueling machine or filling hydraulic reservoir.

Never smoke while adding fuel or oil to machine. Add fluids in a safe place away from open flame and sparks.

Do not allow overflow. Clean up spilled fuel and oil immediately.

Always have a multipurpose dry chemical fire extinguisher filled and available during machine operation and when adding fuel. Know how to use it.



Figure 1.4

General Safety Rules

Operations

HANDLE HAZARDOUS MATERIALS SAFELY

Figure 1.5 - Materials to spread can be dangerous.

Improper selection, application, use or handling may be a hazard to persons, animals, plants, crops or other property.

A Safety Data Sheet (SDS) provides specific details on chemical products: physical and health hazards, safety procedures and emergency response techniques.

Check all SDS's before starting any job using a hazardous material. Follow all instructions and precautions given by the material manufacturer.



Figure 1.5

WORK IN WELL-VENTILATED AREAS

▲ WARNING	Never run machine engine inside a building unless adequate ventilation is provided to safely and properly remove exhaust fumes. Failure to comply with this requirement could result in death or serious injury.
------------------	--

Figure 1.6 - Always work in a properly ventilated area.

Engine exhaust fumes can cause sickness or death. If it is necessary to run an engine in an enclosed area, use proper equipment to safely remove exhaust fumes from the working area.

Open building doors and get fresh air into the working area whenever possible.



Figure 1.6

PROTECT AGAINST NOISE

Figure 1.7 - Long periods of exposure to high decibels or loud noise can cause hearing impairment or loss.

Wear proper hearing protection such as earmuffs or earplugs during periods of exposure to high decibels or loud noise.



Figure 1.7

General Safety Rules

Operations

AVOID MOVING PART HAZARDS

Figure 1.8 - Entanglement in rotating drive lines or moving parts will cause serious injury or death.

Stay clear of all moving parts, such as shafts, couplings and universal joints.

Make sure all personnel are clear of machine before starting.



Figure 1.8

Figure 1.9 - Do not operate machine without all guards and shields closed and secured.

Disconnect and lock out power source before removing guards.

Disconnect and lock out power source before adjusting or servicing.

Keep hands, feet, hair and clothing away from moving parts.

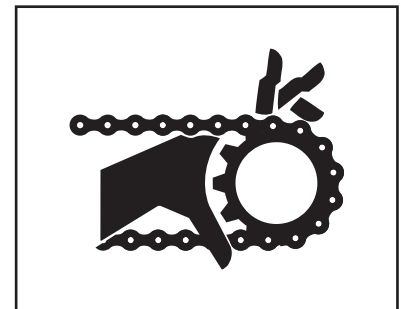

Figure 1.9

Figure 1.10 - Keep away from spinners while they are turning.

Rocks, scrap metal and other material can be thrown from the spinners violently. Stay away from discharge area.

Stop machine before servicing or adjusting. Wear eye protection.

Make sure discharge area is clear before spreading.

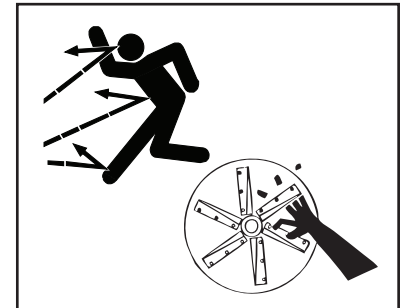

Figure 1.10

Figure 1.11 - Stay out of spreader.

If necessary to enter the spreader, return to shop, empty body, turn off all power, engage brakes, shut down engine and remove keys before entering.

Tag all controls to prohibit operation. Tags should be placed, and removed, by the person working in the body.

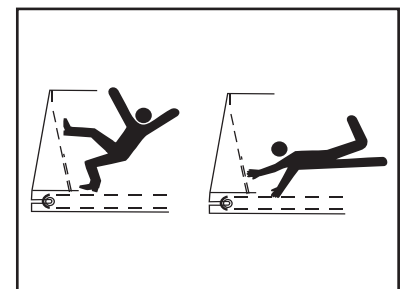

Figure 1.11

General Safety Rules

Operations

DO NOT CLIMB OR STAND ON MACHINE

Figure 1.12 - Never allow any personnel to ride in or on the machine.

Use inspection ladder or portable ladder to view the unit. Use caution when getting on and off the ladder, especially in wet, icy, snowy or muddy conditions. Clean mud, snow and ice from steps and footwear.

Always maintain three-point contact with steps, ladders and handholds. Face the machine when mounting and dismounting inspection ladder. Do not jump off machine.



Figure 1.12

OPERATE MACHINE SAFELY

Always walk around and visually inspect machine before using. Check the immediate vicinity of machine for people and obstructions. Ensure adequate visibility.

Avoid distractions such as reading, eating or operating personal electronics while operating machine. Never operate the machine under the influence of alcohol, drugs or while otherwise impaired.

Always come to a complete stop before reversing. Be sure that all personnel are clear of machine path. Turn around and look directly for best visibility. Ensure all rear view mirrors are properly installed and adjusted. Use a signal person when backing if view is obstructed or when in close quarters.

Always disengage hydraulics before shutting down engine. DO NOT start engine with hydraulics engaged.

General Safety Rules

Transportation & Handling

TRAVELING & TRANSPORTING ON PUBLIC ROADS

Always walk around and visually inspect the machine before traveling on public roads. Check for damage and/or faulty components that can fail and create a hazard or unsafe condition. Make sure all machine systems operate properly, including but not limited to: headlights, tail and brake lights, hazard warning lights, turn indicators, parking brake, horn and rear view mirrors. Repair or replace any component that is not in proper working order.

Never drive machine at a speed that causes it to bounce or cause loss of control.

Obey all traffic safety laws and regulations. Operate the machine with hazard warning lights on, unless prohibited by law. It is the operator's responsibility to activate and use road lights properly while traveling on public roads.

Cover all loads that may spill or blow away. Environmental damage may result. Do not spread dusty materials where dust may create pollution, visibility issues or interfere with traffic on public roads.

When transporting equipment or machine on a trailer, ensure it is properly secured. Be sure that SMV signs on equipment or machine are covered while in transport on a trailer.

Be aware of overhead structures and power lines. Make sure machine can safely pass under. Refer to "Dimensions & Capacities" pages in the Operations section of this manual.

NAVIGATING ROUGH & UNEVEN TERRAIN

Figure 2.1 - Turn slowly and be careful when traveling on rough surfaces and side slopes. Avoid holes, ditches and obstructions that may cause machine to roll over, especially with a loaded spreader.

Never drive near the edge of a gully or steep embankment.

Load may shift, causing vehicle to tip.

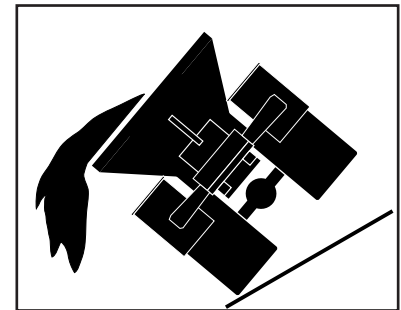

Figure 2.1

General Safety Rules

Maintenance

READ AND UNDERSTAND MAINTENANCE PROCEDURES

Figure 3.1 - Read the maintenance and safety instructions and understand them before performing any maintenance procedure.

Never perform any maintenance procedure or repair if the instructions and safety procedures are not fully understood. Only trained and qualified personnel should perform any maintenance procedure or repair.

Never modify any equipment or add attachments not approved by New Leader Manufacturing.

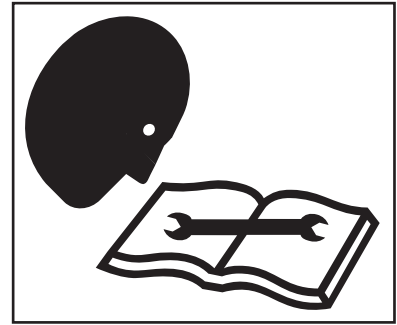

Figure 3.1

DO NOT SERVICE OR ADJUST MACHINE WHILE IN MOTION

Figure 3.2 - Never lubricate, service or adjust the machine or any of its components while they are moving.

Never wear loose clothing or jewelry when working near machine tools or moving parts.

Remove rings and other jewelry to prevent electrical shorts and other personal injury when in contact with machine tools or moving parts.

Close and secure all guards removed for service. Check all screws, bolts, nuts and fasteners for proper torques before operating machine.

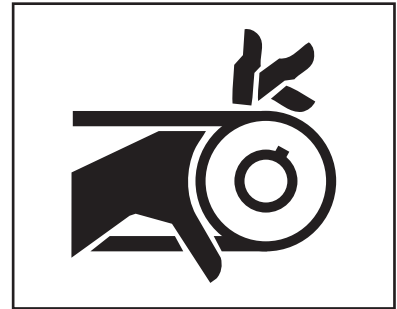

Figure 3.2

WEAR PROPER PROTECTIVE EQUIPMENT

Figure 3.3 - Wear close-fitting clothing and proper safety equipment for the job.

Always wear eye protection when working on or around the machine.

Wear a suitable hearing protection device such as earmuffs or earplugs to protect against high decibels or loud noises.

Prolonged exposure to high decibels or loud noise can cause hearing impairment or loss of hearing.

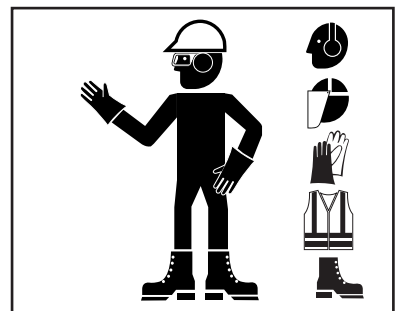

Figure 3.3

Wear protective gloves to protect hands from cuts, abrasions and minor burns.

General Safety Rules

Maintenance

HANDLE FLAMMABLE SOLVENTS SAFELY

Figure 3.4 - Never use diesel fuel, kerosene, gasoline or any flammable solvents for cleaning.

Exposure to toxic fluids or fumes may occur during the normal operation of this system. Before attempting to fill, use, or service this system, read Safety Data Sheets (SDS) to know the specific hazards of the fluids you are using. Always use proper Personal Protective Equipment when attempting to fill, use, or service this system.

Perform work using flammable fluids and solvents in a safe place away from open flame and sparks. Do not smoke.

Do not weld, grind or flame cut on any tank containing oil, fuel, fumes or any other flammable material, or any container that contents or previous contents are unknown. Move all flammable materials and containers away from work area.

Clean up spilled fuel and oil immediately.

Always have a multipurpose dry chemical fire extinguisher filled and available. Know how to use it.



Figure 3.4

USE PROPER LIFTING EQUIPMENT

Figure 3.5 - Use only lifting devices that meet or exceed OSHA standard 1910.184 or ASME B30.20-2013.

Never lift equipment over people.

Never lift a loaded unit. Never lift unit with any loose objects or persons in the body. Loads may shift or fall if improperly supported, causing death, serious injury or machine damage.

Before unfastening heavy parts or assemblies, support with adequate hoist or other device to prevent falling, tipping, swinging or any other movement that may cause injury or damage.



Figure 3.5

USE PROPER TOOLS FOR THE JOB

Figure 3.6 - Use of improper tools (such as a screwdriver instead of a pry bar, pliers instead of a wrench, a wrench instead of a hammer) can cause serious injuries or machine damage.

Use power tools only to loosen threaded parts and fasteners. Using power tools to tighten may cause over-tightening and component damage.

Use only service parts meeting New Leader specifications.

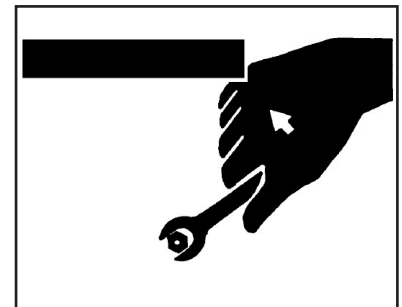

Figure 3.6



General Safety Rules

Maintenance

HIGH PRESSURE FLUID HAZARDS

Figure 3.7 - Escaping fluid under pressure can penetrate the skin causing serious injury.

Always stop machine, allow to cool and relieve pressure before servicing hydraulic system. Never open hydraulic lines under pressure. Make sure all connections are tight and all hoses are in good condition before pressurizing system.

Always use a piece of cardboard or wood to search for leaks instead of hand. Wear impervious gloves and eye protection when servicing system.

Seek medical attention immediately if fluid penetrates your skin. Gangrene may result if wound is left untreated.



Figure 3.7

AVOID HEATING NEAR HIGH PRESSURE FLUID LINES

Figure 3.8 - Flammable spray can be generated by heating near pressurized fluid lines, resulting in burns to yourself and bystanders.

Do not heat by welding, soldering or using a torch near pressurized fluid lines or other flammable materials.

Pressure lines can suddenly burst when heat goes beyond the immediate flame area.

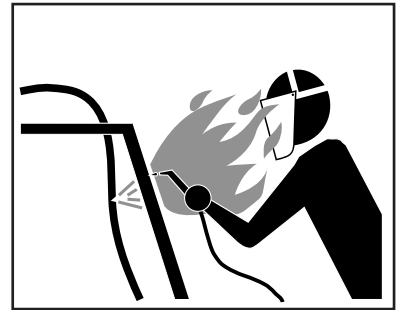

Figure 3.8

AVOID TOXIC FUMES & DUST

Figure 3.9 - Hazardous fumes can be generated when paint is heated from welding, soldering or using a torch.

Remove paint before heating:

- Remove a minimum of 4 in (100 mm) from area to be affected by heating. If paint cannot be removed, wear an approved respirator while heating or welding.
- Avoid breathing dust from sanding or grinding on paint.
- If a solvent or paint stripper is used, wash stripper away with soap and water before heating or welding. Remove solvent or paint stripper containers and other flammable material from area. Allow fumes to disperse for at least 15 minutes before heating or welding.

Do not use chlorinated solvents in areas where welding will take place.

Perform all work in a well-ventilated area that will carry all toxic fumes and dust away.



Figure 3.9

General Safety Rules

Maintenance

CLEAN MACHINE OF HAZARDOUS CHEMICALS

CAUTION

During application of hazardous chemicals, residue can build up on the inside or outside of the vehicle. Clean vehicle according to use instructions of hazardous chemical. Failure to comply with this requirement may result in minor or moderate injury.

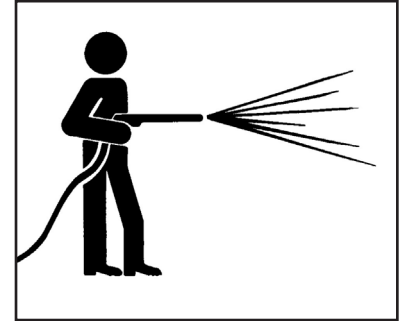

Figure 3.10

Figure 3.10 - When exposed to hazardous chemicals, clean exterior and interior of vehicle daily to keep free of the accumulation of visible dirt and contamination.

1. Clean operator's station to maintain unobstructed visibility of all windows and mirrors, and safe operation of all controls.

NOTICE

Directing pressurized water at electronic/ electrical components, bearings and hydraulic seals or other sensitive parts and components may cause product malfunctions. Reduce pressure and spray at 45 to 90 degree angles.

2. Wash entire exterior of vehicle.
3. Dispose of any wash water with hazardous concentrations of active or non-active ingredients according to published regulations or directives.

HANDLE BATTERIES SAFELY

WARNING

Sulfuric acid in battery electrolyte is poisonous. It can burn skin, eat holes in clothing, and cause blindness if it contacts eyes. Keep sparks and flame away from batteries. Wear proper safety equipment. Failure to comply with this requirement could result in death or serious injury.

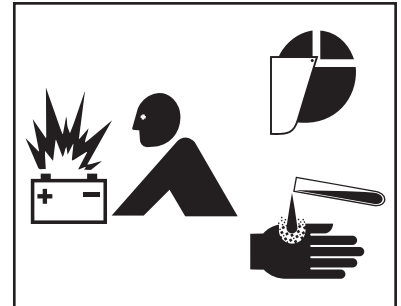

Figure 3.11

Figure 3.11 - Lead acid batteries generate flammable and explosive gases. Keep sparks and flame away from batteries. Do not smoke.

If acid contacts eyes, skin or clothing, flush with water immediately. Seek immediate medical attention if acid contacts eyes.

PROPER TIRE MAINTENANCE

Figure 3.12 - Never weld on a wheel or rim that has a tire on it.

Never attempt to mount or remove a tire unless using the proper equipment, tire safety cage, instructions, training, and you are qualified to perform the work safely. Failure to follow the correct procedures when mounting a tire on a wheel or rim can cause an explosion and serious injury.

Tire service procedures must be performed by trained and qualified personnel.



Figure 3.12

General Safety Rules

Storage

PARK VEHICLE SAFELY

Figure 4.1 - When leaving the vehicle unattended for any reason, be sure to:

- Shut down PTO.
- Shut off vehicle's engine, and unit's engine if applicable.
- Place vehicle transmission in "Neutral" or "Park".
- Set parking brake firmly.
- Remove ignition key and take it with you.
- Block wheels.

These actions are recommended to avoid unauthorized use, runaway, vandalism, theft and unexpected operation during startup.

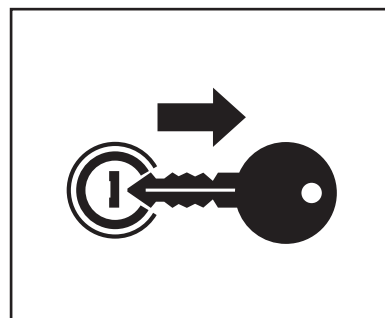

Figure 4.1

SUPPORT MACHINE PROPERLY

Figure 4.2 - When machine is removed from vehicle, always store on adequate supports on a firm level surface. Improper supporting or storage of spreader may cause machine to fall, resulting in serious injury or death.

Never use lifting device to free machine from a chassis, storage stands or frozen ground, or to lift the chassis in any way. Shock loading is prohibited and sudden accelerations must be avoided. Lifting in such a manner could result in injury or machine damage.



Figure 4.2

DISPOSE OF WASTE PROPERLY

Figure 4.3 - Improper disposal of waste can threaten the environment and ecology. Potentially harmful waste used with equipment include items such as fuel, oil, filters and batteries.

Use leakproof containers when draining fluids. Do not use food or beverage containers that may mislead someone into drinking from them. Do not pour waste onto the ground, down a drain, or into any water source.

Comply with all OSHA, local, City, State, Province, Country and jurisdiction regulations, ordinances and standards, related to your particular work area and environment. Inquire on proper disposal methods from your local environmental or recycling center, or from your local dealer.

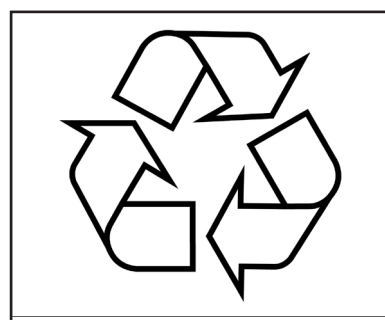

Figure 4.3

Safety Decal Maintenance

Keep safety decals and signs clean and legible at all times.

Replace safety decals and signs that are missing or have become illegible.

Replaced parts that displayed a safety sign should also display the current sign.

Safety decals or signs are available from your dealer's Parts Department or from New Leader Manufacturing by calling (800) 363-1771.

Safety Decal Installation

Clean Surface

Wash the installation surface with a synthetic, free-rinsing detergent. Avoid washing the surface with a soap containing creams or lotion. Allow to dry.

Position Safety Decal

Decide on the exact position before application. Application marks may be made on the top or side edge of the substrate with a lead pencil, marking pen, or small pieces of masking tape. NOTE: Do not use chalk line, china marker, or grease pencil. Safety decals will not adhere to these.

Remove the Liner

A small bend at the corner or edge will cause the liner to separate from the decal. Pull the liner away in a continuous motion at a 180-degree angle. If the liner is scored, bend at score and remove.

Apply Safety Decal

Tack decal in place with thumb pressure in upper corners. Using firm initial squeegee pressure, begin at the center of the decal and work outward in all directions with overlapping strokes. NOTE: Keep squeegee blade even—nicked edges will leave application bubbles. Pull up tack points before squeegeeing over them to avoid wrinkles.

Remove Pre-mask

If safety decal has a pre-mask cover remove it at this time by pulling it away from the decal at a 180 degree angle. NOTE: It is important that the pre-mask covering is removed before the decal is exposed to sunlight to avoid the pre-mask from permanently adhering to the decal.

Remove Air Pockets

Inspect the decal in the flat areas for bubbles. To eliminate the bubbles, puncture the decal at one end of the bubble with a pin (never a razor blade) and press out entrapped air with thumb moving toward the puncture.

Re-Squeegee All Edges

1

CAUTION

HAZARDOUS MATERIALS
To avoid injury or machine damage:

- Materials to be spread can be dangerous.
- Improper selection, application, use or handling may be a hazard to persons, animals, crops or other property.
- Follow instructions and precautions given by the material manufacturer.

321-C

2

DANGER



MOVING PART HAZARD
To prevent death or serious injury:

- Stay out of box while auger is running.
- Disconnect and lockout power source before adjusting or servicing.
- Do not ride on machine.

55977-B

7

WARNING



HIGH PRESSURE FLUID HAZARD
To prevent death or serious injury

- Do not check leaks with hands while system is operating as high pressure oil leaks can be dangerous.
- Release pressure before disconnecting hydraulic lines or working on system.
- Make sure all hydraulic fluid connections are tight and all hydraulic hoses and lines are in good condition before applying pressure to the system.
- Wear protective gloves and safety glasses or goggles when searching for leaks. Use wood or cardboard instead of hands.
- Do not use hydraulic lines for handholds or steps.
- Components may be hot.
- Get immediate medical attention if skin is placed with fluid as gangrene may result.

308156-B

6

WARNING



Failure to follow operating instructions could result in death or serious injury.

Read and understand operator's manual before using this machine.

308156-B

3

CAUTION



TO AVOID INJURY OR MACHINE DAMAGE:

- Do not operate or work on this machine without reading and understanding the operators manual.
- Keep hands, feet, hair and clothing away from moving parts.
- Do not allow riders on machine.
- Avoid unsafe operation or maintenance.
- Disengage power takeoff and shut off engine before removing guards, servicing or unloading machine.
- Keep unauthorized people away from machine.
- Keep all guards in place when machine is in use.
- If manual is missing, contact dealer for replacement.

305274-B

12

WARNING



To prevent death or serious injury:

- Do not ride on ladder or fenders.

305274-B

5

WARNING



FALLING HAZARD
To prevent death, serious injury or machine damage:

- Do not stand or climb on guard.

308153-A

4

DANGER



FLYING MATERIAL & ROTATING SPINNER HAZARD
To prevent death or serious injury:

- Wear eye protection.
- Stop machine before servicing or adjusting.
- Keep bystanders at least 60 feet away.

308153-B

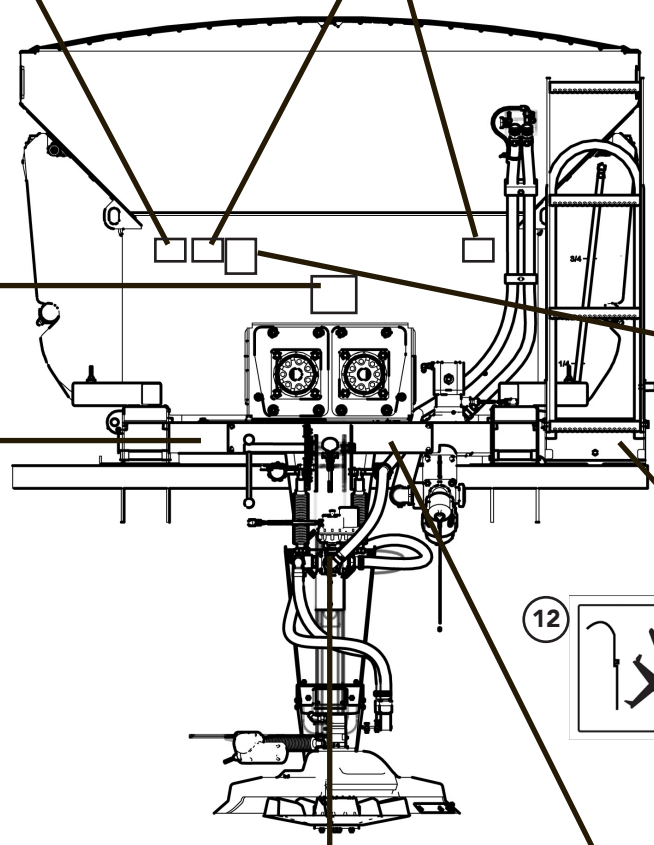

Safety Decals Continued

8

WARNING

MOVING PART HAZARD
 To prevent death or serious injury:

- Close and secure guards before starting.
- Do not stand or climb on machine.
- Disconnect and lockout power source before adjusting or servicing.
- Keep hands, feet and hair away from moving parts.

56631-C

9

DANGER



CRUSH HAZARD
 To prevent death or serious injury:

- Do not stand between truck and spreader.
- Do not stand behind truck while in motion.

308194-B

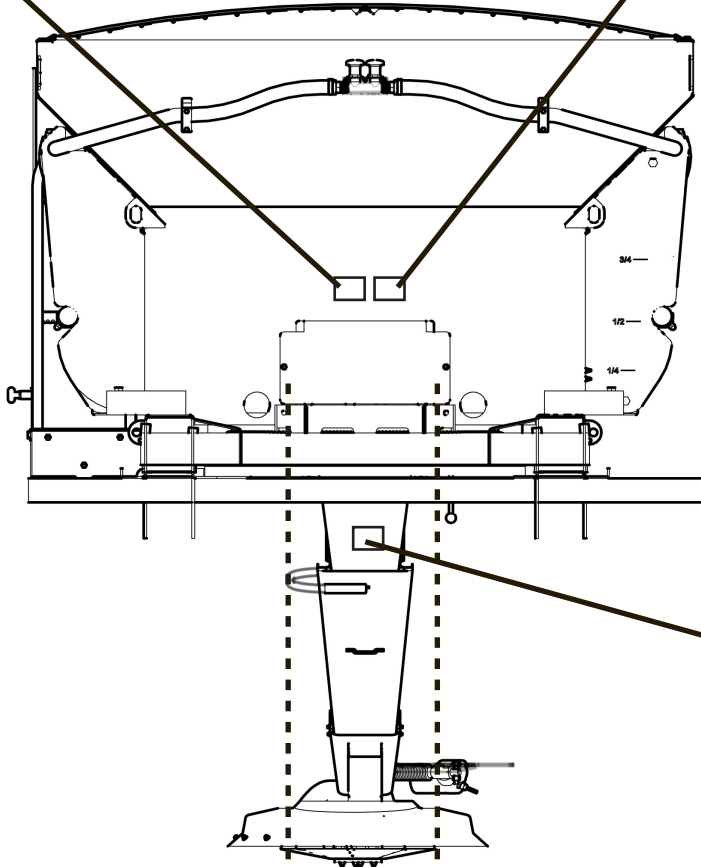

10

WARNING



FALLING SPINNER HAZARD
 To prevent death or serious injury:

- Stay out from under spinner in raised position or while lowering hopper.
- Do not operate or transport in raised position.
- Keep away from rotating spinner.

71887-C

11

DANGER

GUARD IS MISSING WHEN THIS IS VISIBLE
 To prevent death or serious injury:

- Do not operate this unit without guard in place.

308191-A

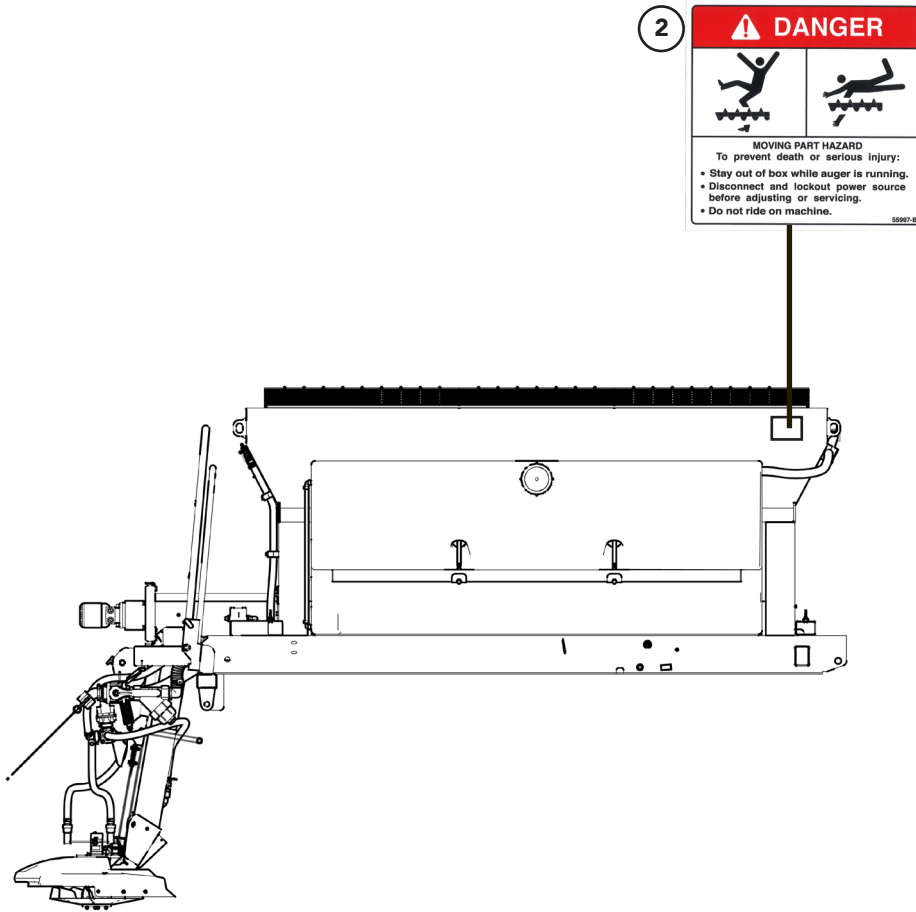

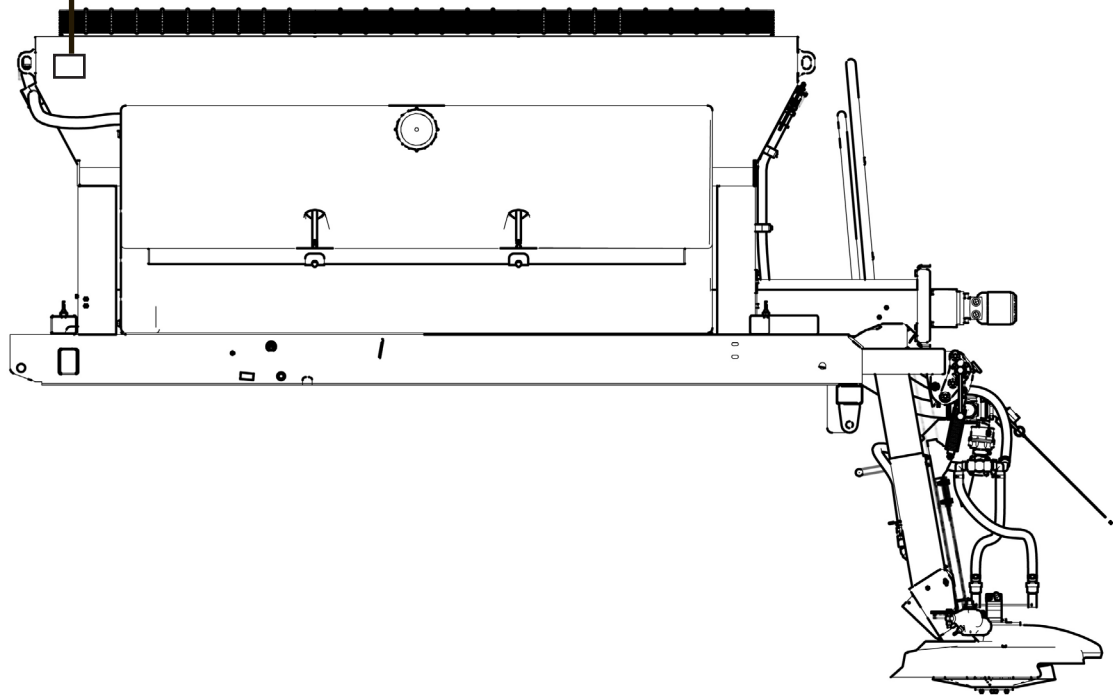

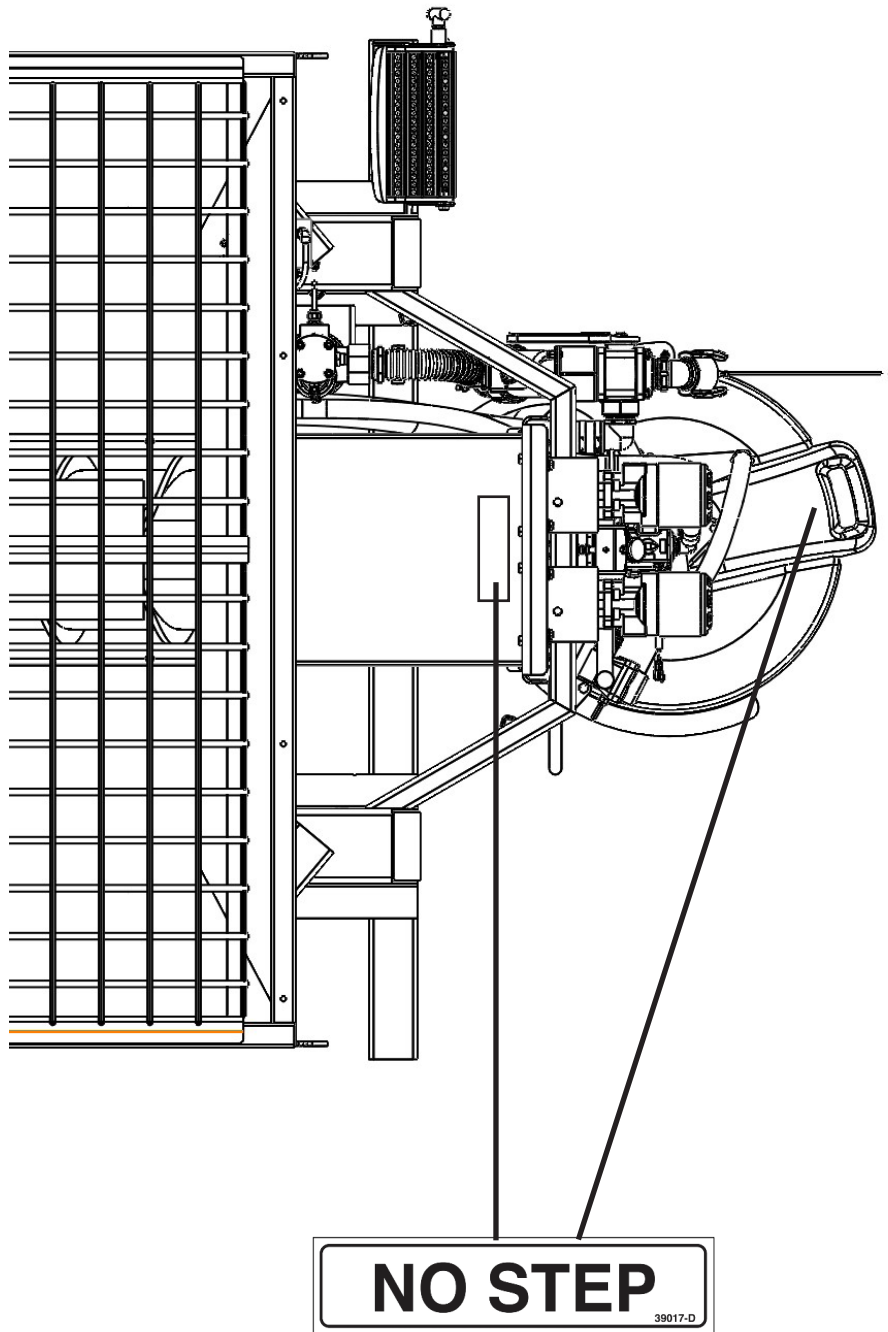

Safety Decals Continued

1. CAUTION: HAZARDOUS MATERIALS

To avoid injury or machine damage:

- Materials to be spread can be dangerous.
- Improper selection, application, use or handling may be a hazard to persons, animals, crops or other property.
- Follow instructions and precautions given by the material manufacturer.

2. DANGER: MOVING PART HAZARD

To prevent death or serious injury:

- Stay out of box while auger is running.
- Disconnect and lock out power source before adjusting or servicing.
- Do not ride on machine.

3. CAUTION: TO AVOID INJURY OR MACHINE DAMAGE:

To avoid injury or machine damage:

- Do not operate or work on this machine without reading and understanding the operator's manual.
- Keep hands, feet, hair and clothing away from moving parts.
- Do not allow riders on machine.
- Avoid unsafe operation or maintenance.
- Disengage power takeoff and shut off engine before removing guards, servicing or unclogging machine.
- Keep unauthorized people away from machine.
- Keep all guards in place when machine is in use.
- If manual is missing, contact dealer for replacement.

4. DANGER: FLYING MATERIAL AND ROTATING SPINNER HAZARD

To prevent death or serious injury:

- Wear eye protection.
- Stop machine before servicing or adjusting.
- Keep bystanders at least 60 feet away.

5. WARNING: FALLING HAZARD

To prevent death or serious injury or machine damage:

- Do not stand or climb on guard.

6. WARNING: MOVING PART HAZARD

To prevent death or serious injury:

- Failure to follow operating instructions could result in death or serious injury.
- Read and understand operator's manual before using this machine.



Safety Decals Continued

7. WARNING: HIGH-PRESSURE FLUID HAZARD

To prevent death or serious injury:

- Do not check leaks with hands while system is operating as high pressure oil leaks can be dangerous!
- Relieve pressure before disconnecting hydraulic lines or working on system.
- Make sure all hydraulic fluid connections are tight and all hydraulic hoses and lines are in good condition before applying pressure to the system.
- Wear protective gloves and safety glasses or goggles when searching for leaks. Use wood or cardboard instead of hands.
- Do not use hydraulic lines for hand holds or steps.
- Components may be hot.
- Get immediate medical attention if skin is pierced with fluid as gangrene may result.

8. WARNING: MOVING PART HAZARD

To prevent death or serious injury:

- Close and secure guards before starting.
- Do not stand or climb on machine.
- Disconnect and lockout power source before adjusting or servicing.
- Keep hands, feet and hair away from moving parts.

9. DANGER: CRUSH HAZARD

To prevent death or serious injury:

- Do not stand between truck and spreader.
- Do not stand behind truck while in motion.

10. DANGER: FALLING SPINNER HAZARD

To prevent death or serious injury:

- Stay out from under spinner in raised position or while lowering hopper.
- Do not operate or transport in raised positions.
- Keep away from rotating spinner.

11. DANGER: GUARD IS MISSING WHEN THIS IS VISIBLE

To prevent death or serious injury:

- Do not operate this unit without guard in place.

12. WARNING: FALLING HAZARD

To prevent death or serious injury or machine damage:

- Do not ride on ladders or fenders.

INSTALLATION

Installation Instructions

In mounting the Model EA2 spreader on a chassis, the following questions must be considered:

1. Is the CA (Cab to Axle) dimension of the truck (for chassis mounting) and/or the length of the truck's dump body (for dump body mounting) correct for the length of the spreader?

To answer this question, the following chart will assist in matching spreader to truck:

Spreader Inside Body Length (Feet)	Truck CA/CT Dimension (Inches)	Truck Dump Body Length (Feet)
10	84 CA	10
12	102 CA	12
14	120 CT	14

NOTICE The Cab to Axle/Tandem dimensions are only guidelines. Consult federal, state and local weight laws and chassis manufacturer's ratings to ensure neither government weight restrictions, nor GVWR and GAWRs are exceeded.

2. Is the truck's GAWR (Gross Axle Weight Rating) and the GVWR (Gross Vehicle Weight Rating) adequate to carry the fully loaded spreader?

To answer this question, refer to your Hi-Way dealer. He knows where to find the GAWR and GVWR for most trucks, and how to calculate the weight distribution on each axle and total loaded vehicle weight.

3. How will the hydraulic pump be driven?

The answer to this question will depend upon the availability of means to drive a pump that exist on the particular truck chosen for the mounting. Your dealer should be able to help here as well. However, the pump to be used will be determined by both the pump drive selected and the hydraulic control system chosen.

Hydraulic Requirements

Hydraulics		GPM (LPM) (Gallons/Liters per Minute)	Maximum Pressure (PSI)
Dual Auger V-Box	Spinner & Auger	10 (38)	3000

NOTICE Hydraulic motors are reverse rotation. Plumb as shown below.

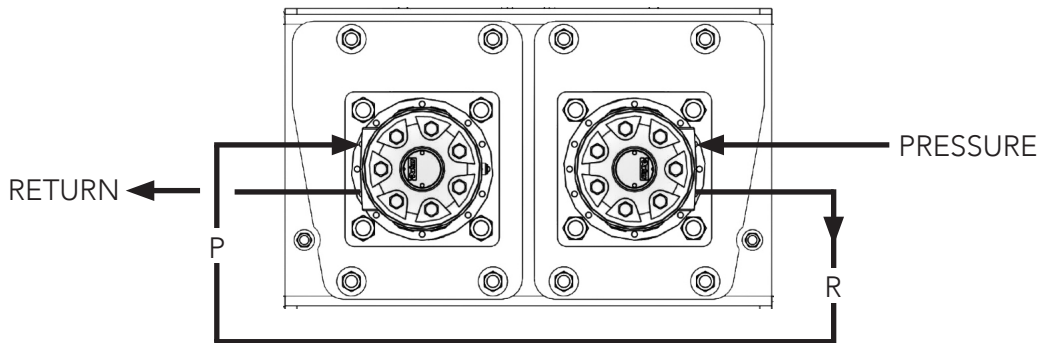

Hydraulic Motors



Installation Instructions

Mounting Requirements

If mounting the spreader directly to a frame, a level top surface is necessary for mounting. Add steel shim bars or strips the same thickness as fish plates or other obstructions and as wide as the truck frame channel top flange. Shims must be drilled to clear any rivet or bolt heads.

Truck Chassis Installation

Lifting the Spreader

⚠ WARNING

Use only lifting devices that meet or exceed OSHA standard 1910.184 or ASME B30.20-2006. Never lift equipment over people. Never lift unit with anything or anybody in the body. Loads may shift or fall if improperly supported. Failure to comply with this requirement could result in death or serious injury.

⚠ CAUTION

Do not use lifting device to free unit from a chassis, storage stands or frozen ground, or to lift the chassis in any way. Shock loading is prohibited and sudden accelerations should be avoided. Failure to follow this requirement may result in injury or machine damage.

Always inspect unit lift points for signs of wear, cracking, corrosion, gouges, alterations, or distortion.

Always use a sling, spreader bar, or lifting bar that attaches to the lifting points with a minimum of 60 degrees from horizontal. It is preferable to use an "H" style lifting bar that keeps the attaching chains in a near vertical orientation as shown in Figure 1. Operators of lifting devices must be qualified and knowledgeable in their use and application.

Position the chassis with adequate room around the unit. Work in an environment that permits clear communication to others nearby. Keep area clear of persons when loads are to be lifted and suspended. Do not allow the lifted load to come in contact with any obstruction.

Store units on a solid surface using appropriate storage stands when not installed.

Attach lifting bar to spreader and remove slack. Remove Lift spreader for installation onto truck chassis.

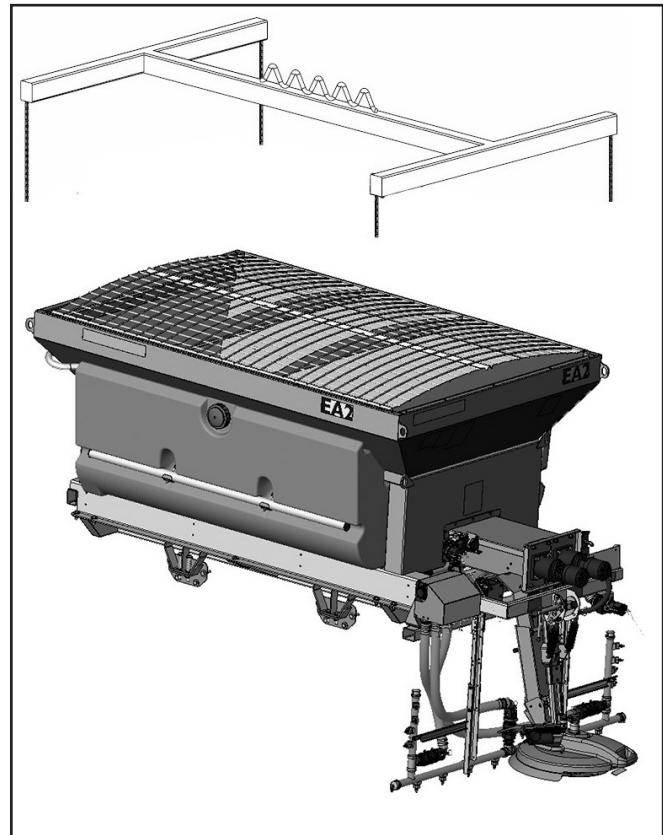

Figure 1 - Lifting Bar

Installation Instructions

Securing to Frame

CAUTION

Be careful when drilling so as to not damage truck frame, fuel tank, or any other important components. Failure to follow this requirement may result in injury or machine damage.

NOTICE

DO NOT WELD ON VEHICLE FRAME! Such welding can lead to fatigue cracking and must be avoided.

NOTICE

DO NOT PUT HOLES INTO TOP OR BOTTOM FLANGES—to do so may void truck manufacturer's warranty. When drilling holes in frame member, drill only through vertical web portions.

NOTICE

Connect welders ground directly to one of the items being welded anytime an arc welder is used on the vehicle or anything connected to the vehicle. Refer to Manufacturer's instructions.

IMPORTANT!

Disconnect electrical components from electrical system when welding on equipment to prevent component damage due to power surges or excessive current.

Front Mount Angles

Assemble two front mounting angle springs and hardware. Use a 3/8" (10mm) shim between cross tube mounting plate and truck frame mounting angle. Position assembly ahead of front subframe mount and against truck frame, make sure springs do not contact subframe. Mark position of mounting angle holes on truck frame. Drill 9/16" (14mm) holes where marked and install mounting assembly using 1/2" hardware supplied. Weld mounting plate to side of subframe on three sides, and remove 3/8" (10mm) shim (Figure 2). Tighten spring assembly until spring compressed height is 4" (102cm). There should be a 3/8" (10mm) space between cross tube mounting plate and truck frame mounting angle (Figure 2). Repeat this procedure on other side of truck frame, directly across from opposite mount.

Rear Mount Plates

Rear mounting plates are not factory supplied. Fabricate mounting plates out of 1/4" steel plate. The mounts must provide sufficient area to weld to DOT EA2 subframe and to bolt to truck frame with four 1/2" grade 8 (13mm 10.9) bolts per side. See Figure 2 for example guidelines.



Dump Body Installation

Spreader Preparation

Roller Sidebars

The four roller sidebars are intended to guide the spreader along the sidewalls during loading and unloading. Settings on each side of the spreader must be equal to center spreader on the dump body.

NOTE: If the dump body has large radiused corners, the sidebars can be flipped to increase the height of the roller.

1. Measure the inside width of the dump body at the front just above any radiused corner.
2. Measure the distance between the two front rollers on the spreader as shown in Figure 1. Start from the outside edge of one roller and measure to the outside edge of the opposite roller.

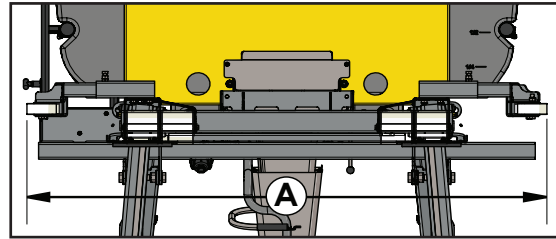

Figure 1 - Distance Between Front Rollers

3. Adjust the roller sidebars as necessary so distance between rollers is just less than the inside width of dump body:
 - a. Loosen the locknut (A) and bolt (B) on top of side bar.
 - b. Adjust roller sidebars as shown in Figure 2. Align bolt with sidebar hole.
 - c. Verify the distance between two front rollers. Adjust if necessary.
 - d. Tighten bolt so it is securely in sidebar hole.
 - e. Tighten locknut.

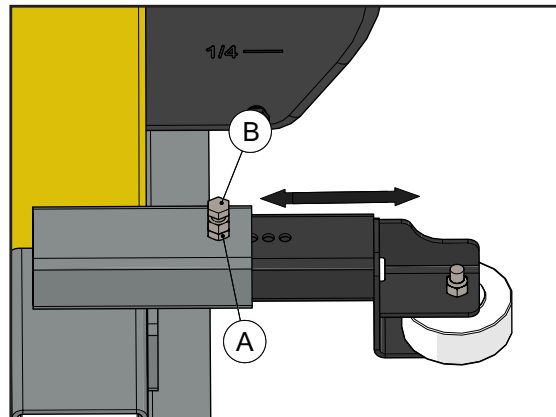

Figure 2 - Adjust Roller Sidebars

4. Repeat for the two rear roller sidebars.

Loading

The Highway Storage Leg System (HSL) is designed to be used where the dump body floor is between the height of 50" to 62". The height of the legs will need to be adjusted for first time use to match the dump body floor height. The legs should be adjusted so the spreader sits level or slightly elevated at the front.

Check to make sure the vehicle is suitable for the spreader. Consider all other auxiliary equipment such as front snow plows, wings and scrapper blades. Consider the total weight of the spreader, liquid and granular materials.

The dump body floor must be clear of sand, salt, snow, ice or any other debris and the four rubber pads should always contact the floor when the spreader is installed.

1. Raise loading platform approximately 10°.
2. Figure 1 - Back truck underneath spreader until spreader's front leg supports leave the ground.

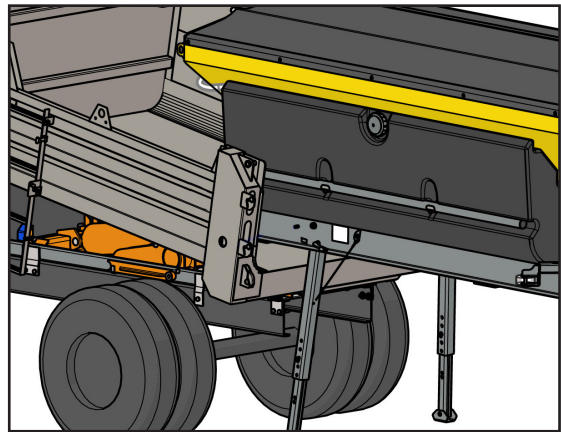

Figure 1 - Loading

3. Apply truck's parking brake and chock wheels.
4. Figure 2 - Attach safety strap to chassis and tighten so strap is taut. Front legs remain locked.

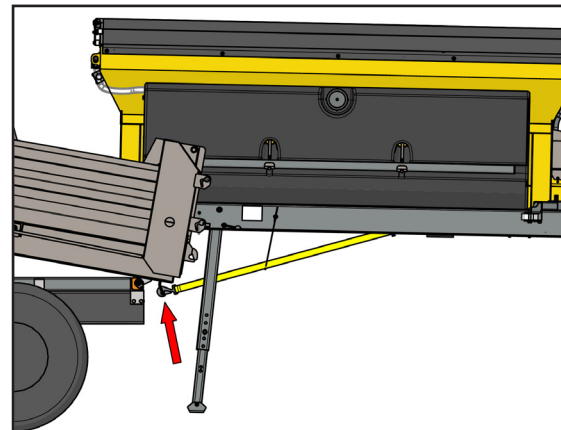

Figure 2 - Attach Safety Strap

5. Figure 3 - Remove front leg locking pins (A). Store front leg locking pins in hole (B).

NOTE: On high truck floors and short spreader bodies, the front legs may need to be shortened to fold up.

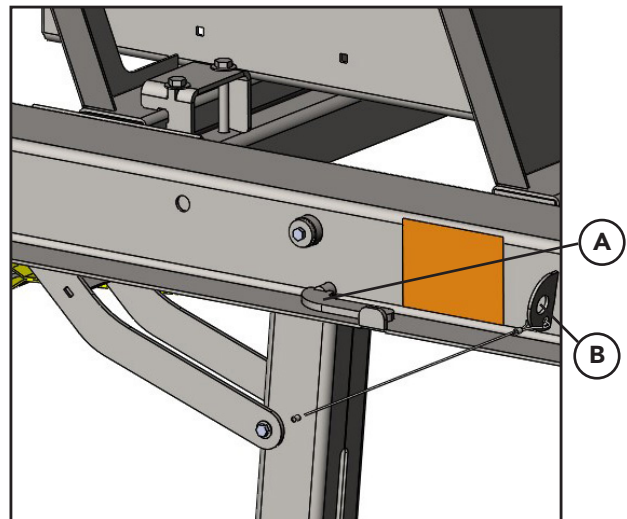

Figure 3 - Leg Support Lock Pin

NOTICE

Spreader angle may need to be increased or decreased to properly position on truck.

6. Figure 4 - Continue to back dump body underneath spreader until truck makes contact with spreader.
7. Apply truck's parking brake and chock wheels.

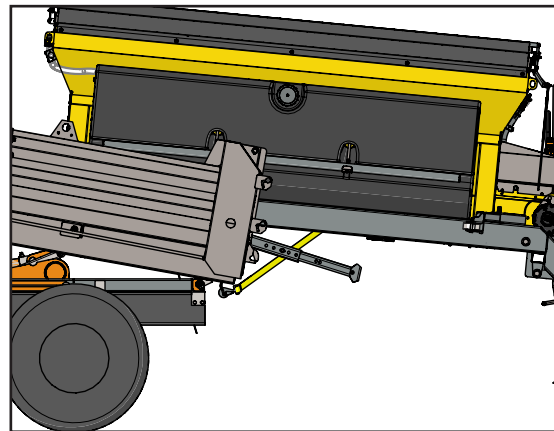

Figure 4

8. Figure 5 - Lower the dump body completely. The rear legs should be off the ground.

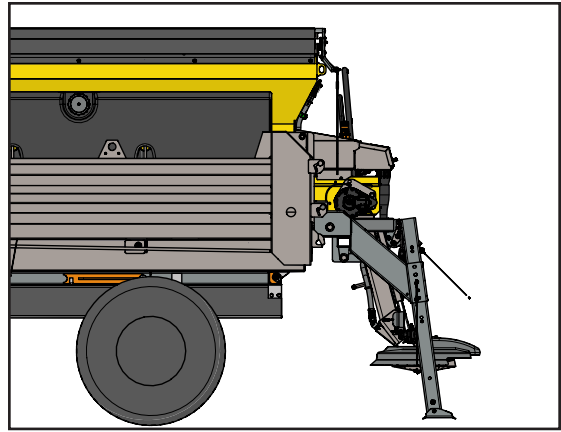

Figure 5

9. Figure 6 - Raise rear legs:
 - a. Remove lock pin (A).
 - b. Grip rear leg at handle (B).
 - c. Lift leg above the height of the spinner.
 - d. Insert lock pin into hole (C).

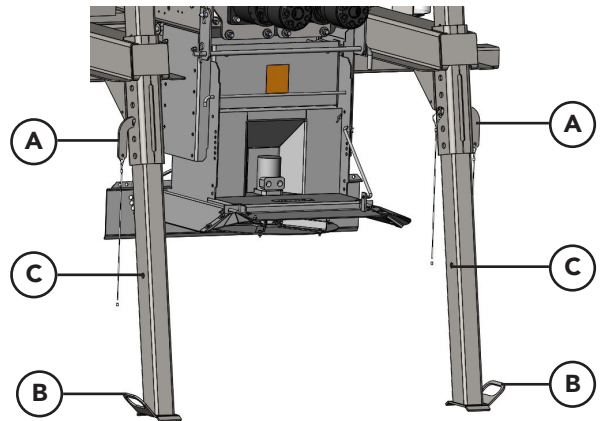

Figure 6 - Rear Leg detail

10. Secure spreader. See Securing Spreader section.
11. Hook up all connections between spreader and chassis.

Securing Spreader

⚠ WARNING

Inspect securing devices and tie-down points for wear and tear. Replace securing device and repair tie-down points if any sign of wear or damage. Make sure securing devices do not contact sharp edges, moving or hot components. Failure to comply with this requirement could result in death or serious injury.

Spreader must be secured to dump body to eliminate movement caused by braking, cornering and acceleration of truck. Operator is responsible for supplying and attaching appropriate securing devices as the spreader can be installed in many different types of dump bodies with a variety of tie downs. The Federal Motor Carrier Safety Administration may be used as a guide for securing loads.

Ensure roller sidebars are correctly positioned to restrict side-to-side movement.

⚠ CAUTION

Avoid sharp edges and corners when attaching straps to prevent personal injury. Failure to follow this requirement may result in injury or machine damage.

Secure spreader to chassis and dump body with ratchet straps, mounting to the securing hooks located at each corner of the spreader, on the top and the sides.



Removal From Dump Body

Reference illustrations on previous pages in reverse order as necessary.

1. Empty spreader of all liquid and granular materials.
2. Drive to level, firm surface to unload spreader. Take truck out of gear and set parking brake.
3. Disconnect all hydraulic and electrical connections from spreader to truck.
4. Remove devices used to secure spreader.
5. Lower rear legs of spreader to approximately 1" (5cm) from ground and lock in position.
6. Ensure safety strap on bottom side of spreader is still connected to dump body.
7. Raise dump body approximately 10°, so the spreader's rear legs touch the ground and the rubber pads lift off of the dump body floor.
8. Drive truck forward, sliding spreader out of box until front leg locking pins can be removed.
9. Drive truck forward until front legs fold down.
10. Take truck out of gear, set parking brake and chock wheels.
11. Set front legs approximately 1" (5cm) from ground and lock in position. Secure in upright position with locking pin through subframe.
12. Unhook safety strap from truck.
13. Slowly drive truck out from under spreader. Lower dump body.

Hydraulic Hose Installation Guide

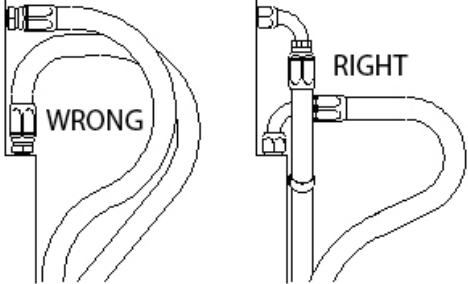
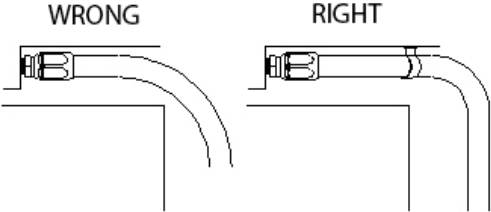
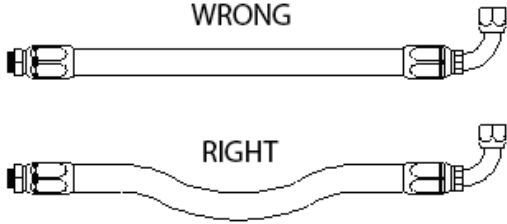
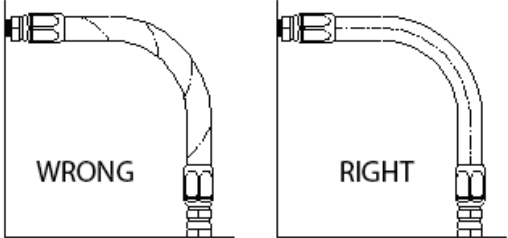
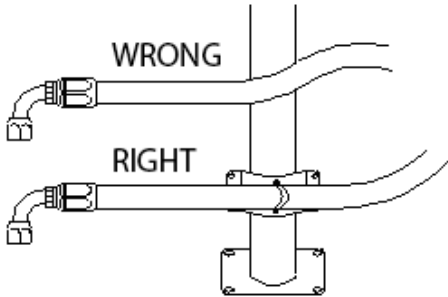
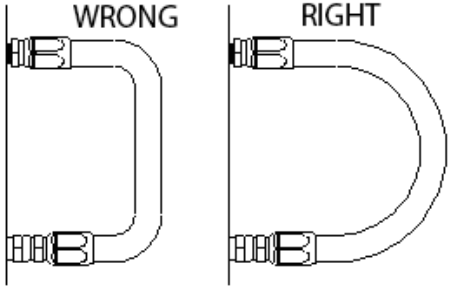
	
<p>1. Use elbows and adapters in the installation to relieve strain on the assembly, and to provide easier and neater installations that are accessible for inspection and maintenance. Remember that metal end fittings cannot be considered as part of the flexible portion of the assembly.</p>	<p>2. Install hose runs to avoid rubbing or abrasion. Clamps are often needed to support long runs of hose or to keep hose away from moving parts. It is important that the clamps be of the correct size. A clamp that is too large will allow the hose to move in the clamp causing abrasion at this point.</p>
	
<p>3. In straight hose installations allow enough slack in the hose line to provide for changes in length that will occur when pressure is applied. This change in length can be from +2% to -4%.</p>	<p>4. Do not twist hose during installation. This can be determined by the printed layline on the hose. Pressure applied to a twisted hose can cause hose failure or loosening of the connections.</p>
	
<p>5. Keep hose away from hot parts. High ambient temperature will shorten hose life. If you cannot route it away from the heat source, insulate it.</p>	<p>6. Keep the bend radii of the hose as large as possible to avoid hose collapsing and restriction of flow. Follow catalog specs on minimum bend radii.</p>

(Used with the permission of The Weatherhead Company.)

Installation Instructions Cont.

Ladder – Side

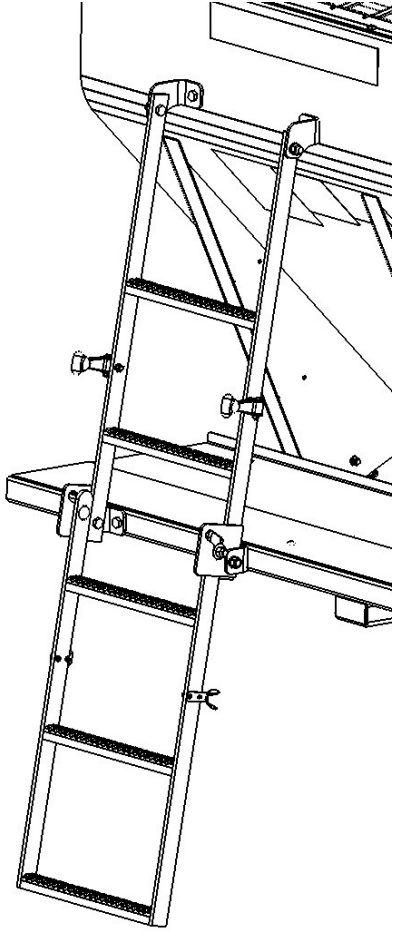

Position upper ladder in a suitable location on fender and side sheet as shown in Figure 1. Mark holes on side sheet and fender. Remove ladder and drill 9/16" holes. Attach to side sheet with hardware.

Tighten all hardware to recommended torque.

NOTE: Longer bolts are used to attach mounts to ladder and shorter bolts are used to attach mounts to sidesheet or fender.

Figure 1 – Side Ladder Installation

Parts needed:

Description	Qty
Bracket - Mount Ladder 304	2
Bracket - Mount Ladder Lh 304	1
Bracket - Mount Ladder Rh 304	1
Capscrew - .5-13nc X 1.25 SS	4
Capscrew - .5-13nc X 1.5 SS	4
Ladder - Side Assy 304	1
Nut - Hex .5-13nc SS	8
Washer - Lock .5 SS	8

Installation Instructions Cont.

Ladder – Rear

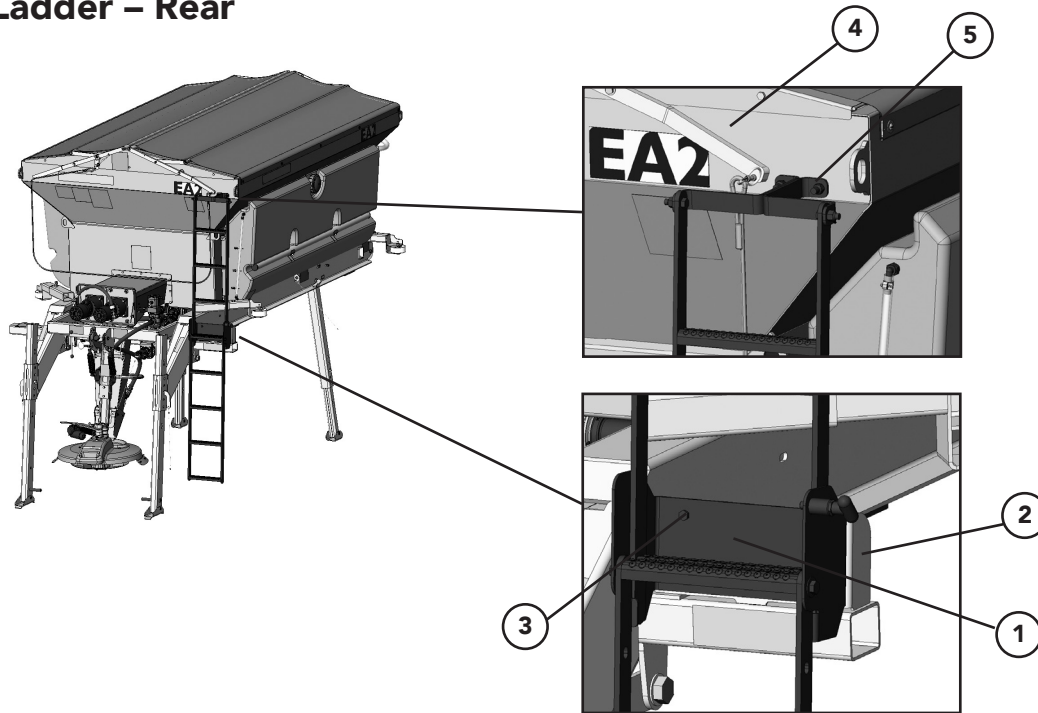

Figure 1 – Rear Ladder Installation

Parts needed:

Description	Qty
Ladder - Wldmt Rear Upper 304	1
Ladder - Wldmt Rear Lower 304	1
Washer - Flat .5 SS	4
Capscrew - .5-13NC X 1.5 SS	7
Nut - Lock .5-13NC SS	7
Capscrew - .375-16NC X 1 SS	3
Nut - Hex .375-16NC SS	3
Brace - Ladder 304	2

Position ladder so that ladder mount (1) can be attached to frame assembly (2) using 3/8" Capscrews and Nuts (3) as shown in Figure 1.

Position upper ladder against Endgate (4) as shown in Figure 1. Mark holes on Endgate. Remove ladder and drill 9/16" holes. Attach to endgate with 1/2" Capscrews, Washers and Nuts (5).

Tighten all hardware to recommended torque.

Installation Instructions Cont.

Cab Shield

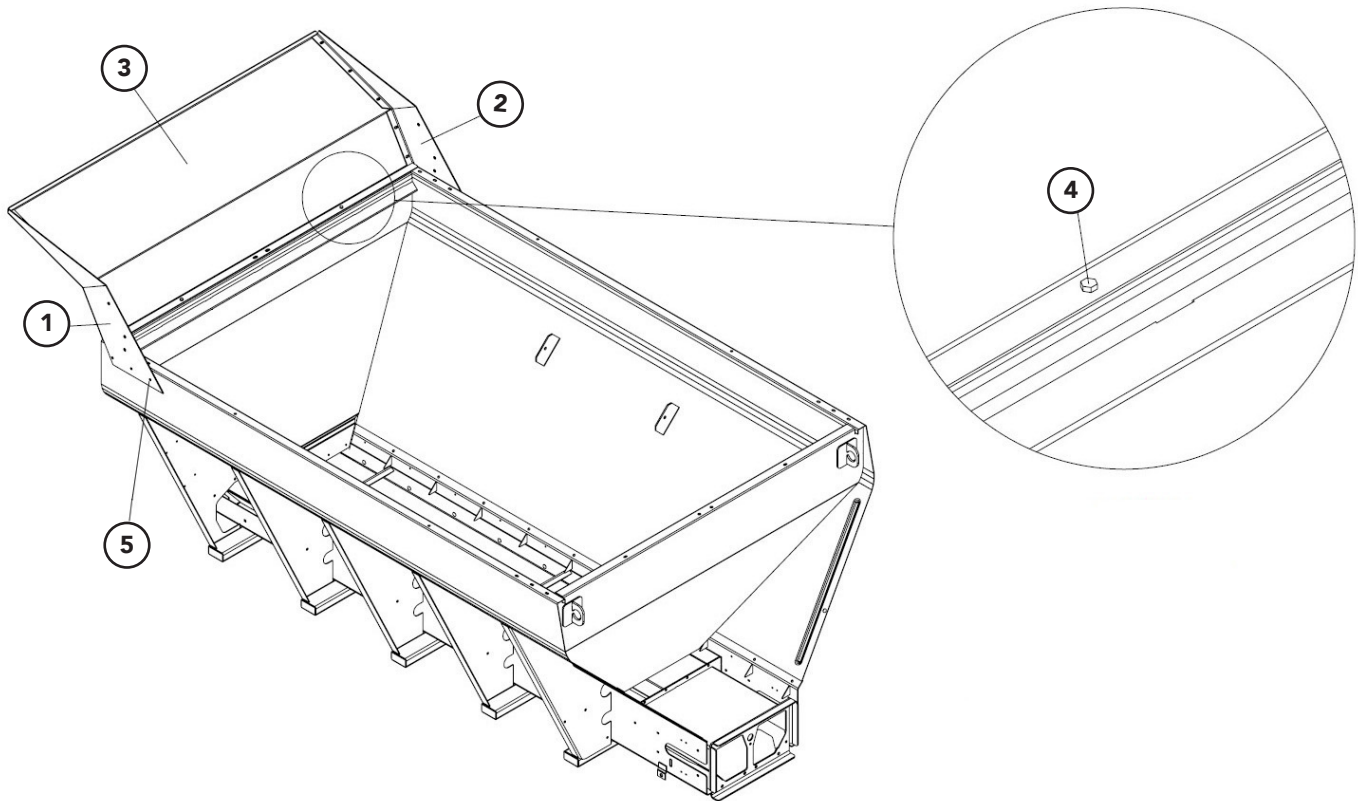

Figure 1 – Cab Shield Installation

Parts needed:

Description	Qty
Panel - Cab Shield 57 304	1
Support - Wldmt Rh 304	1
Support - Wldmt Lh 304	1
Nut - Hex .375-16nc SS	20
Washer - Flat .375 SS	10
Washer - Lock .375 SS	20
Capscrew - .375-16nc X 1 SS	20

Attach Supports (1,2) to Cab Shield (3) with Capscrews, Washer, Lock Washer and Hex Nuts (4) but do not tighten. Center Cab Shield on front of the unit as shown in Figure 1 and mark the hole locations on the front endgate and both sides. Remove the Cab Shield and drill 7/16" holes where marked. Install Cab Shield using Capscrews, Lock Washers and Hex Nuts (5). Tighten all hardware to recommended torque.

Installation Instructions Cont.

Fenders

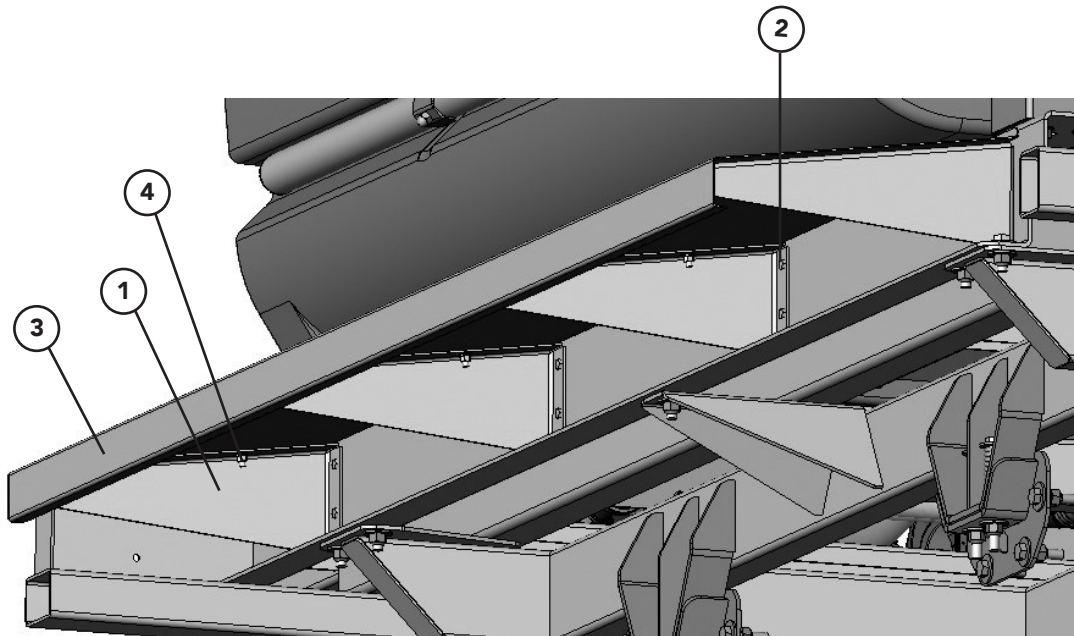

Figure 1 – Fender Installation

Parts needed:

Description	Qty	
Fender Panel	2	Attach Fender Angles (1) to spreader using 3/8" Capscrews, Lock Washers and Hex Nuts (2) as shown in Figure 1. Do not tighten the hardware at this time. Attach Fender Panels (3) on top of fender angles using 3/8" Carriage Bolts, Flat Washers, Lock Washers and Hex Nuts (4). Tighten angle and panel hardware to recommended torque. Repeat on opposite side.
Angle – Fender	AR	
Capscrew - 3/8 x 1 1/4	AR	
Carriage Bolt - 3/8 x 1	AR	
Flat Washer – 3/8	AR	
Lock Washer – 3/8	AR	
Hex Nut – 3/8	AR	

This page is intentionally left blank.

OPERATIONS

Operations

General Description

The EA2 is a hopper-type spreader with direction control intended for accurate and even spreading of material for snow and ice control. Material combines with liquid at a high 70% salt to 30% de-icing solution ratio, such as salt brine or calcium chloride. This provides for better granular salt activation, less material bounce and better placement control. The unit can also spread dry sand.

The unit is powered hydraulically, providing independent, variable speed control for the spinner, auger and liquid system flow. The control provides on-the-go adjustment of directional spinner allowing placement of mixture where needed.

Dual seven-inch (18cm) augers run the full length of the bottom to dispense material at the rear of the body. Each auger is driven by a hydraulic motor through a planetary gearcase.

The spinner sits below the unit and locks in an upright position when not in use or unloading. Material can be spread from 6 to 36 ft., or up to three lanes wide. Material moves from the hopper, down the chute and onto the spinner. Liquid is mixed with the granular material at the end of the chute and on the spinner disc assembly. Spinner height is set independently by changing the length of the chute.

This product is intended for use by trained personnel only.



IMPORTANT!

Please consult federal, state, and local weight laws and chassis manufacturer's ratings to ensure neither government weight restrictions nor GVWR and GAWR's are exceeded. Tire and tandem axle size may require mounting modification of optional mud flaps.

TCMT

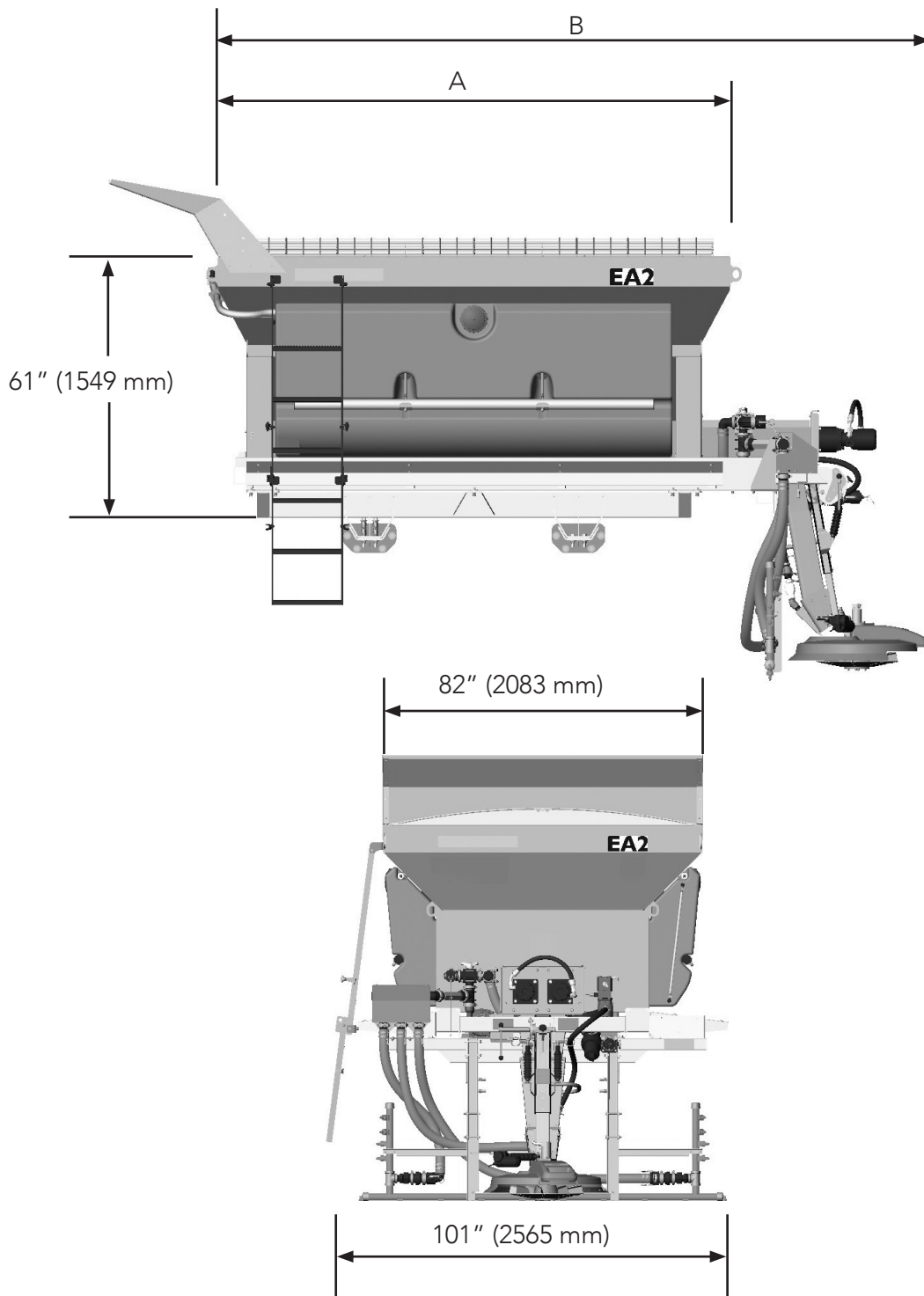

Dump Body

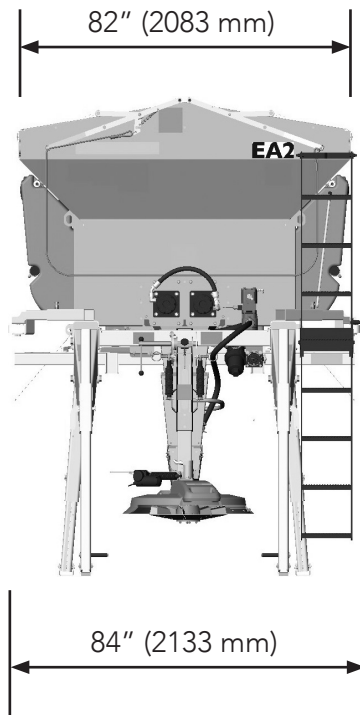
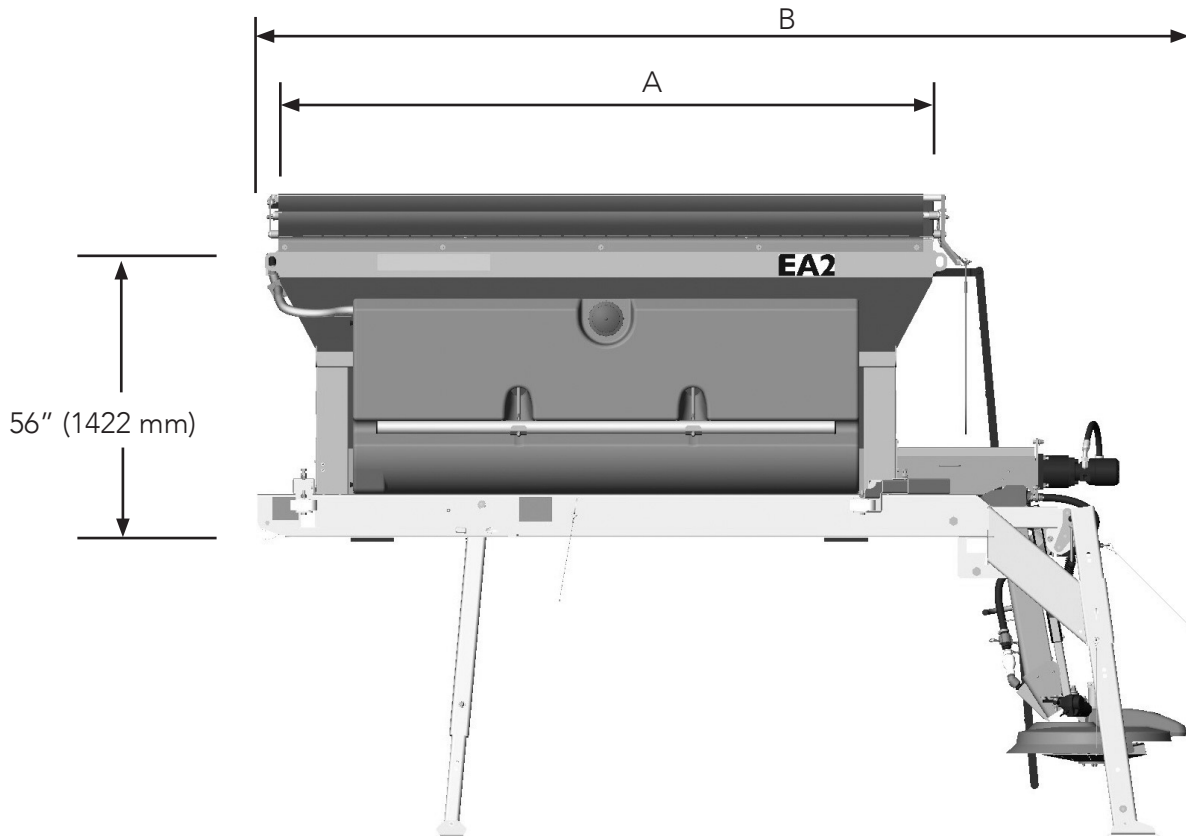

Dimensions & Capacities Continued

EA2

Unit Length	10' (3.05m)	12' (3.66m)	14' (4.27m)
Inside Length (A)	120" (3048mm)	144" (3658mm)	168" (4216mm)
Overall Length (B)	174" (4420mm)	198" (5029mm)	222" (5639mm)
Approximate Weight lbs (kg)	4000 (1814)	4400 (1996)	4800 (2177)
Struck Capacity Cu Ft (Cu m)	141 (4.0)	173 (4.9)	203 (5.7)
Rounded Capacity Cu Ft (Cu m)	167 (4.7)	205 (5.8)	243 (6.9)
Liquid Capacity Gal (L)	464 (1756)	594 (2249)	724 (2741)



This page is intentionally left blank.

⚠ WARNING

DO NOT check leaks with hands while system is operating as high pressure oil leaks can be dangerous! If skin is pierced with hydraulic fluid at high pressure seek immediate medical attention as fluid injected into the skin could cause gangrene if left untreated. Relieve pressure before disconnecting hydraulic lines or working system. Make sure all hydraulic fluid connections are tight and all hydraulic hoses and lines are in good condition before applying pressure to the system. Wear protective gloves and safety glasses or goggles when working with hydraulic systems. Failure to comply with this requirement could result in death or serious injury.

⚠ WARNING

DO NOT check for leaks adjacent to moving parts while system is operating as there may be danger of entanglement! Failure to comply with this requirement could result in death or serious injury.

Before taking the unit out to use, make a walk-around inspection to assure that unit is not damaged, that all essential parts are in place, and that all fasteners are tight and all guards are in place. Check all controls to be sure they are operating satisfactorily.

Spinner

⚠ WARNING

Spinner is counterbalanced to aid lifting. Do not stand under spinner when raising or lowering. Falling spinner can cause injury. Do not adjust spinner position when machine is operating to avoid entanglement, causing injury or death. Failure to comply with this requirement could result in death or serious injury.

Storage Position

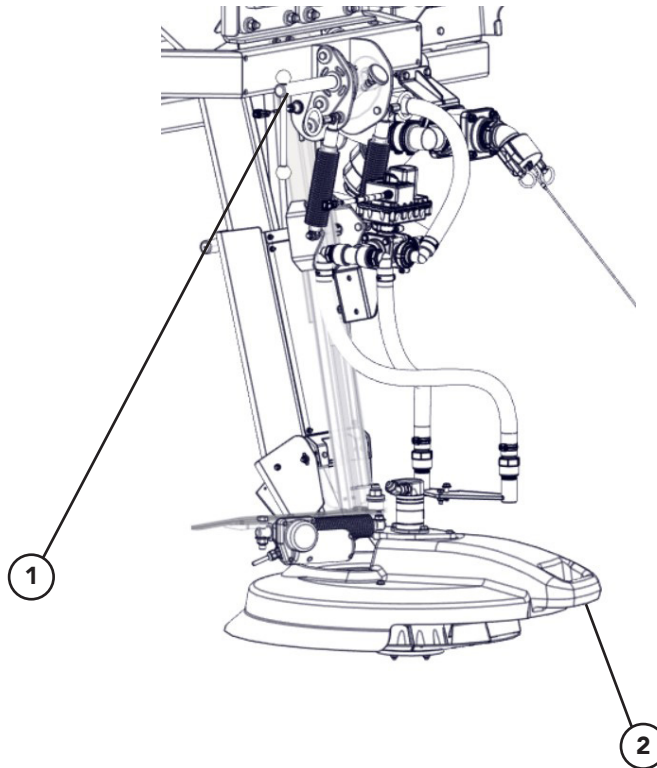

Figure 1

1. Turn Handle (1) counterclockwise to release spinner.
2. Grip Handle on rear of spinner hood (2) and raise spinner to storage position.
3. Turn Handle (1) clockwise until clamp is tight.

Spreading Position

1. Loosen clamp two full turns.
2. Grip handle on back of chute and begin to lower the spinner assembly.
3. Use spinner hood handle to finish lowering system until it can't go any further.
4. Tighten clamp. Clamp must be tightly closed for spinner to operate.

Drop Point

The drop point, or point on the spinner cone at which the bottom part of the chute is aimed, must be set to 1-3/16" (30mm) above the spinner disc, \pm 3/16" (5mm).

1. Position spinner to produce a symmetrical spread pattern, such as 3' left hand and 3' right hand..
2. Hold a flat strip or equivalent flush against inside, bottom of chute with the strip's bottom touching the spinner hub.
3. Figure 2 - Measure the distance between where the strip hits the spinner hub and the base of the hub.

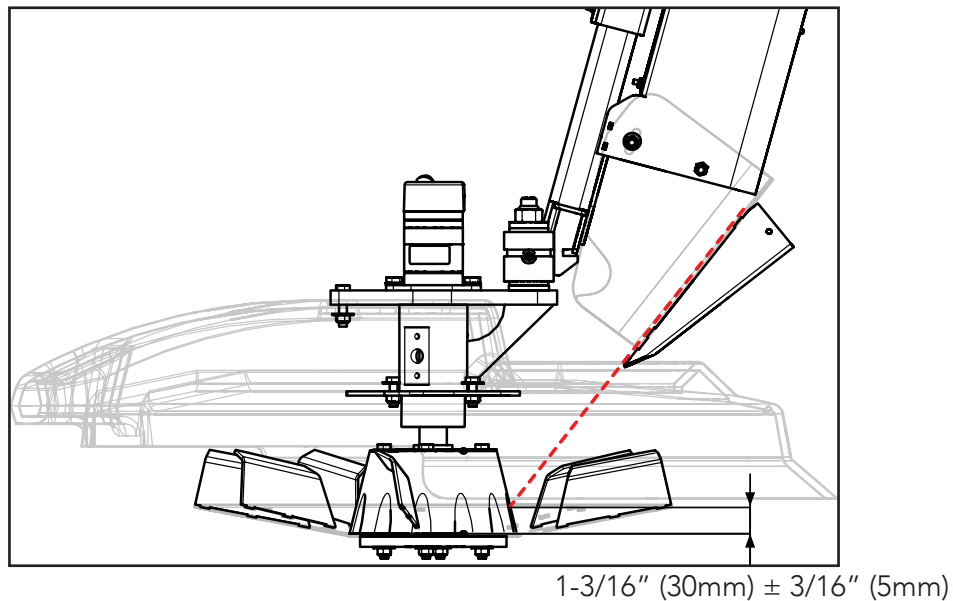

Figure 2 - Drop Point

4. Adjust as needed:
 - Loosen hardware on bottom of chute where chute meets the spinner hood.
 - Aim bottom part of chute at correct drop point.
 - Adjust to 1-3/16" (30mm) \pm 3/16" (5mm).
 - Tighten chute hardware.
 - Verify distance.

Setting Spinner Height

NOTICE

Set spinner height when spreader is half full. Spinner height may be different between a full and empty load.

Spinner disc must be horizontal to ground when spreading. If disc is not horizontal to ground, spread pattern will be off. Adjust spinner as necessary.

1. Set spinner to Horizontal.

- Figure 3 - Verify that clamp is tight (A).
- Loosen spinner clamp hardware (B) two turns each.
- Position disc horizontal to ground.
- Verify that rubber stop on spinner pivot between mounting ears is holding spinner nearly horizontal or at a slight angle. Adjust as necessary.
- Tighten spinner clamp hardware to proper torque.

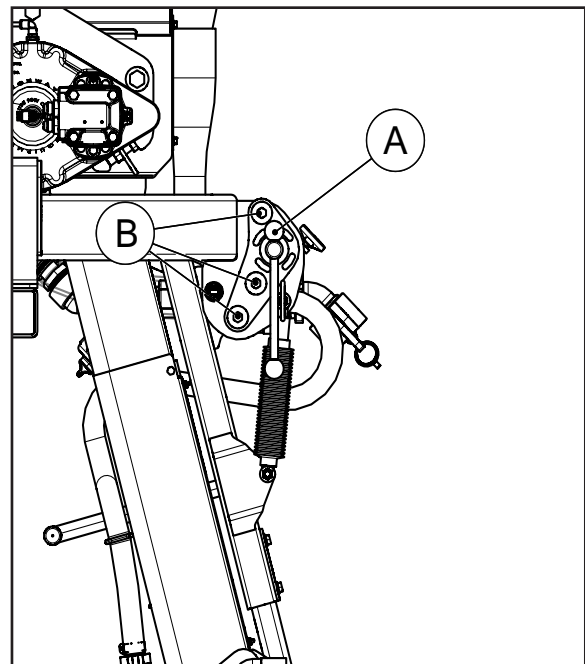

Figure 3

2. Adjust spinner height.

- Figure 4 - Measure distance from outer edge of spinner disc to ground. Distance between disc and road surface must be $16'' \pm 2''$ (356-457mm). Note difference between required and actual height of disc.

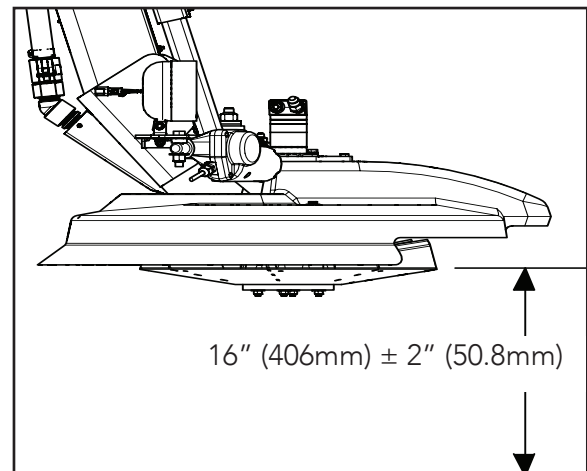

Figure 4

- Figure 5 - Loosen clamp and raise distribution system until horizontal to ground. Tighten clamp to hold position.
- Loosen hardware on chute lock plate (1) indicated in Figure 5.
- Move chute difference noted in step 2a. If disc is too high, move chute rearward. If too low, move forward.
For example: actual height of spinner disc is 13". Move chute forward three inches to achieve required spinner height.
- Tighten bolts.
- Lower chute to proper position and tighten clamp.
- Verify spinner height and repeat previous steps if necessary.

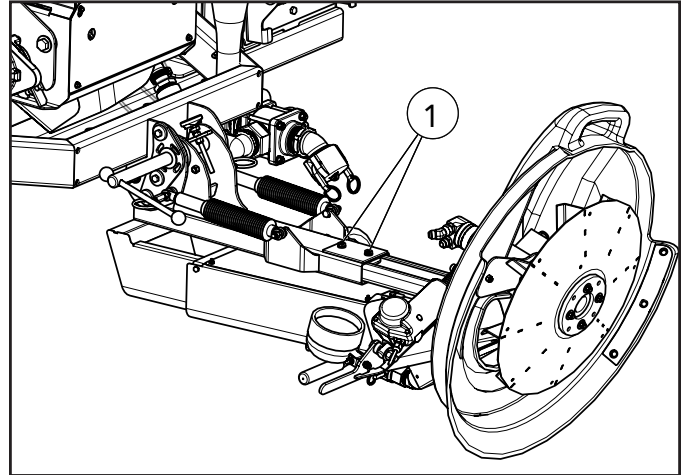

Figure 5

Filling Hopper

⚠ WARNING Stand clear of moving machinery and hopper when loading material to avoid injury or crushing. Failure to comply with this requirement could result in death or serious injury.

⚠ WARNING Load and unload spreader on a level firm surface. Failure to do so could cause spreader to tip. Failure to comply with this requirement could result in death or serious injury.

NOTICE Do not allow loading device to contact hopper. Doing so could cause damage.

Only use high quality, granular material for best performance.

Liquid System

The liquid system can be filled through tank caps on side tanks or with connection on rear of spreader.

Filling Liquid Tanks

⚠ CAUTION Load spreader on truck before filling tanks. Liquid weight could collapse free-standing spreader, causing injury and damage to spreader. Failure to follow this requirement may result in injury or machine damage.

NOTICE Valve must be in run position before operating liquid system or damage to pump may occur.

NOTICE Refer to liquid tank capacity before filling tanks.

Tarp

See tarp manufacturers manual.

The liquid system can be filled through tank caps or connection on rear of spreader.

Liquid Valve

To set liquid valve, turn handle to proper position as referenced below in Figure 2.

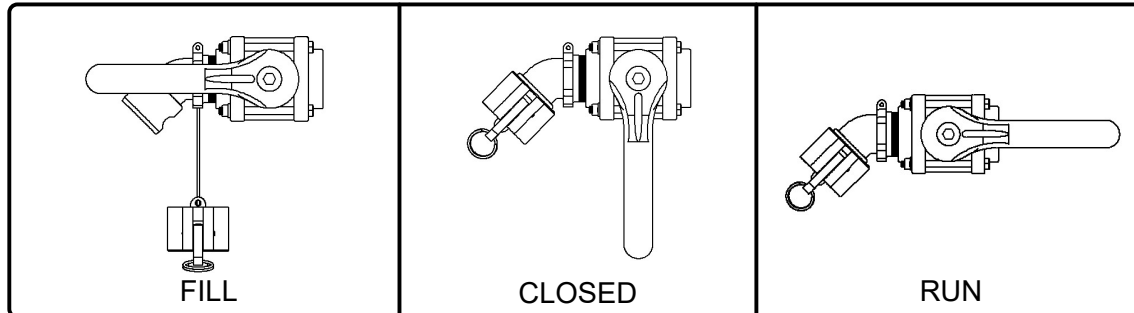

Figure 2A - Fill Position Figure 2B - Close Position Figure 2C - Run Position

NOTE: Close valve before connecting filling hose.

- Fill Position while filling the liquid tanks.
- Closed Position after spreading and during maintenance.
- Run Position while spreading.

Filling Liquid Tanks

CAUTION Load spreader on truck before filling tanks. Liquid weight could collapse free-standing spreader, causing injury and damage to spreader.

NOTICE Valve must be in run position before operating liquid system or damage to pump may occur.

NOTICE Refer to liquid tank capacity at beginning of manual before filling tanks.

Valve Fill

The liquid system can be filled by one of two methods:

- Direct Tank Fill: Remove cap from the center of the side tank and fill directly.
- Ground Pump Fill: Use when filling station has its own pump.

1. Turn liquid valve to "Closed" position (Figure 2B).

2. Figure 3 - Unlock liquid valve cap and remove.

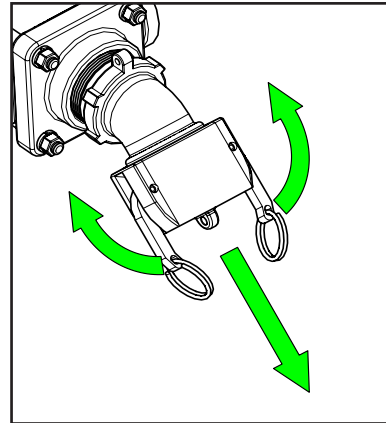

Figure 3 - Liquid Valve Cap

3. Attach filling hose to liquid valve.

4. Turn liquid valve to "Fill" position (Figure 2A).

5. Figure 4 - Fill tanks to the desired amount indicated by sight gauge attached to rear of right tank.

6. Turn liquid valve to "Closed" position.

7. Remove filling hose from liquid valve.

8. Turn liquid valve to "Run" position (Figure 2C).

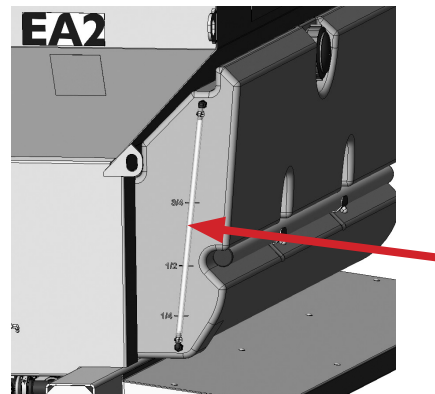

Figure 4 - Liquid Tank Gauge

Post-Spread

⚠ WARNING

Stand clear of moving machinery and hopper when loading or unloading material to avoid entanglement or being crushed. Failure to comply with this requirement could result in death or serious injury.

⚠ WARNING

Load and unload spreader on a level, firm surface. Storing spreader on uneven or soft surface could cause spreader to tip causing death, serious injury or damage. Loading on soft surface could cause spreader to sink making removal difficult or causing damage. Failure to comply with this requirement could result in death or serious injury.

Emptying Hopper

1. Once at the desired location for unloading, lock spinner in upward position.
2. Set metering gate to "Unload" position.
3. Use controller "Unload" function to run conveyor.
4. Refer to control system's operation manual for instructions.

Emptying Liquid Tanks

Set liquid valve to "Fill" position. Tanks will empty by gravity drain.

NOTE: Controller liquid "Unload" function can be used to empty tanks. Refer to control system's operation manual for instructions.

Spread Rate Limits

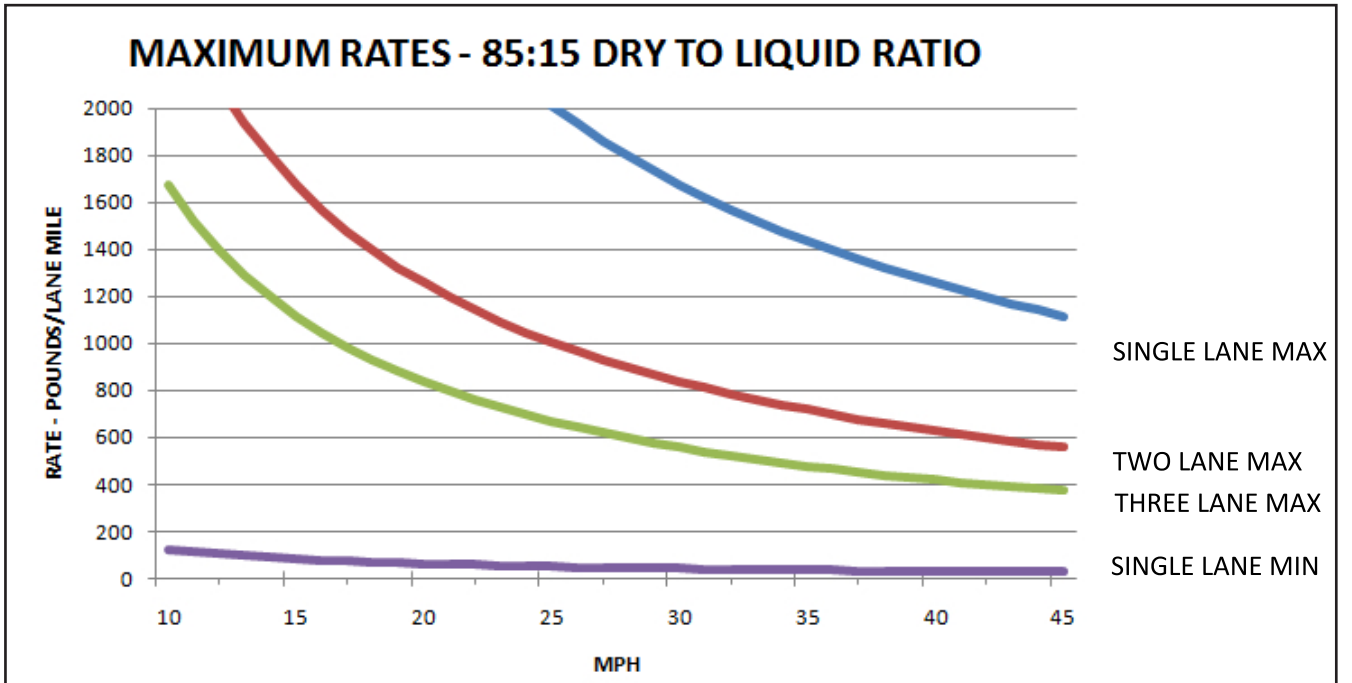
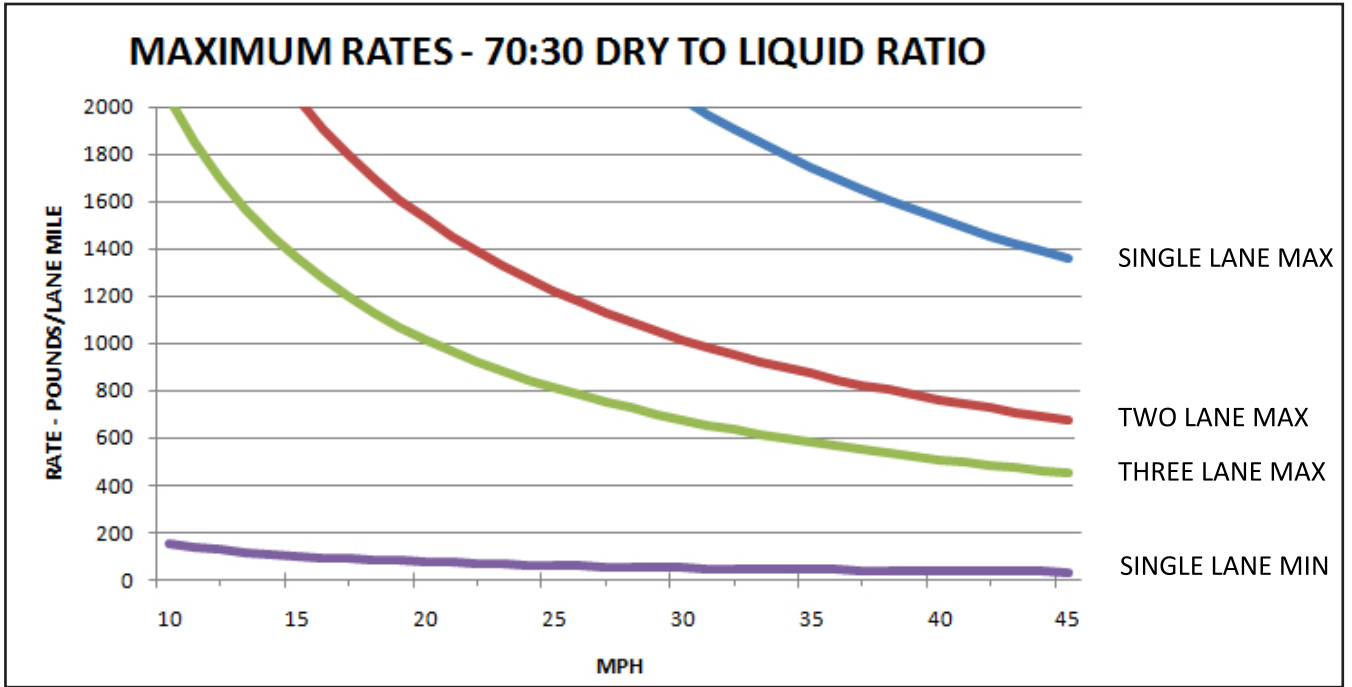

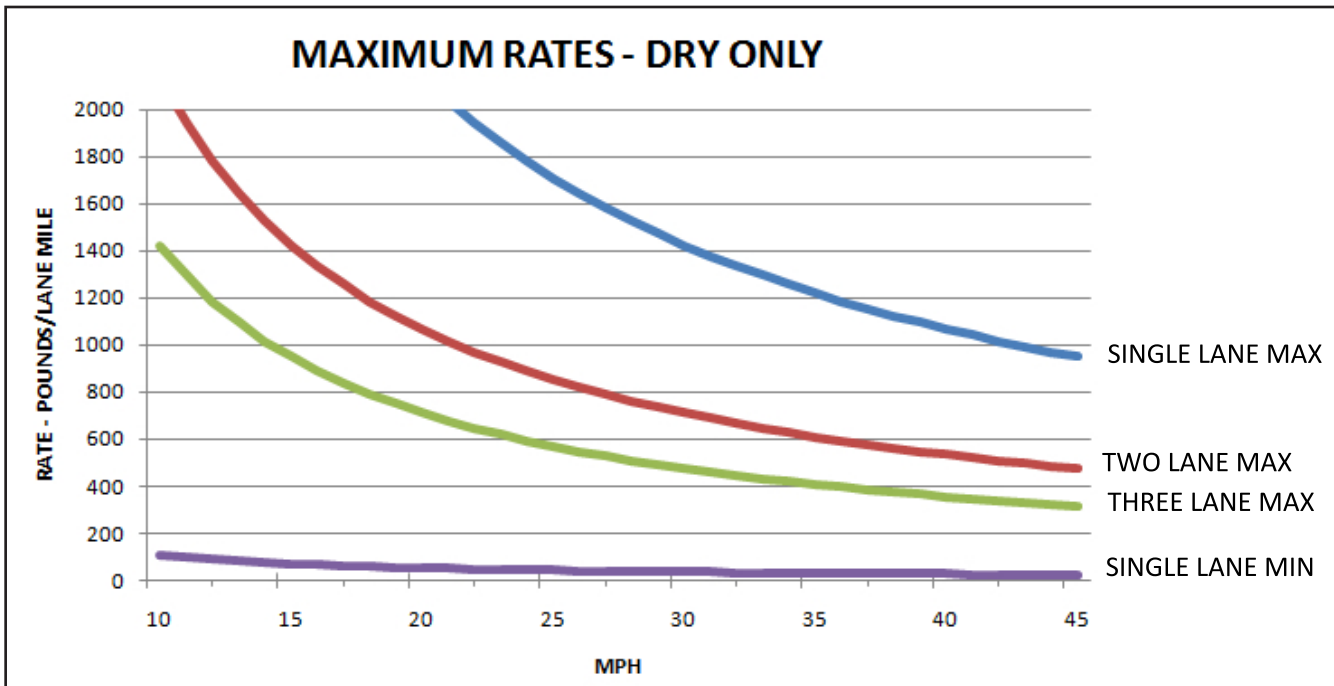

Typical Liquid Densities

LIQUID	DENSITY lbs/gal
Salt Brine	10.2
Calcium Chloride	10.92
Magnesium Chloride	10.53

NOTE: Liquids have specific gravity mixture. Consult product labels.

This page is intentionally left blank.

This page is intentionally left blank.

MAINTENANCE

Maintenance

Lubrication and Maintenance

Preventative Maintenance Pays!

The handling and spreading of salt and sand is a highly severe operation with respect to metal corrosion. Establish a frequent, periodic preventative maintenance program to prevent rapid deterioration to equipment. Proper cleaning, lubrication and maintenance will yield longer life, more satisfactory service and more economical use of your equipment.

⚠ WARNING

Shut off all power and allow all moving parts to come to rest before performing any maintenance operation. Failure to comply with this requirement could result in death or serious injury.

Hydraulic System

Proper oil in the hydraulic system is one of the most important factors for satisfactory operation. Utmost cleanliness in handling the oil cannot be stressed enough. Keep hydraulic oil in original closed containers, clean top of container before opening and pouring, and handle in extremely clean measures and funnels.

Refer to "Lubricant and Hydraulic Oil Specifications" for selection of the proper hydraulic fluid for use in the hydraulic system.



Lubrication & Maintenance

Hydraulic Hose

Hose assemblies in operation should be inspected frequently for leakage, kinking, abrasion, corrosion or other signs of wear or damage. Worn or damaged hose assemblies should be replaced immediately.

⚠ WARNING

Testing should be conducted in approved test stands with adequate guards to protect the operator. Failure to comply with this requirement could result in death or serious injury.

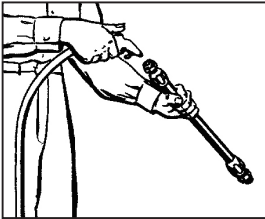

Clean

Clean assembly by blowing out with clean compressed air. Assemblies may be rinsed out with mineral spirits if the tube stock is compatible with oil, otherwise hot water at 150°F (65.55° C) maximum may be used.

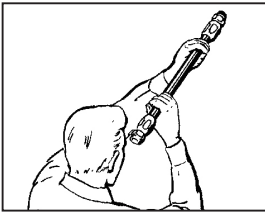

Inspect

Examine hose assembly internally for cut or bulged tube, obstructions, and cleanliness. For segment style fittings, be sure that the hose butts up against the nipple shoulder; band and retaining ring are properly set and tight, and segments are properly spaced. Check for proper gap between nut and socket or hex and socket. Nuts should swivel freely. Check the layline of the hose to be sure the assembly is not twisted. Cap the ends of the hose with plastic covers to keep clean.

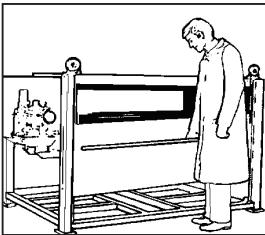

Test

The hose assembly should be hydrostatically tested at twice the recommended working pressure of the hose.

Test pressure should be held for not more than one minute and not less than 30 seconds. When test pressure is reached, visually inspect hose assembly for: 1. Any leaks or signs of weakness. 2. Any movement of the hose fitting in relation to the hose. Any of these defects are cause for rejection.

Storage and Handling

Hose should be stored in a dark, dry atmosphere away from electrical equipment, and the temperature should not exceed 90° F (32.22° C).

Electrical System

NOTICE

Refer to control system's operation manual for correct battery voltage for spreader and Auger. Incorrect voltage can cause damage to the control box and/or spreader's electronics.

NOTICE

DO NOT weld on spreader while power supply is connected to spreader and control box. Damage could occur to the electric system.

Periodically check electrical connections and cables for wear or damage. Disconnected plugs must always be protected from corrosion; cap all unused plugs with a sealed end. Before reconnecting components, remove any corrosion from connectors and lubricate with electrical contact spray.

Liquid System

NOTICE

Ensure liquid system is filled with salt solution or other agent at all times to prevent freezing.

Liquid Pump

The liquid pump must always be "primed" to avoid corrosion of internal components. If the pump is left dry, liquid will not be delivered initially when Auger is activated. Flush the liquid system with non-corrosive agent if system is idle for 5-10 days to avoid crystallization of chemicals in pump. Flush pump with hot water should crystallization occur.

See "Filling the Liquid Tanks" in Operations section for filling instructions.

Suction Strainer

Clean the suction strainer with water weekly or after every major event.

Figure 1 - Turn liquid valve to the "Closed" position and unscrew cap behind liquid valve. Remove strainer and rinse with water until clean, replace as necessary. Replace strainer and screw cap on tight.

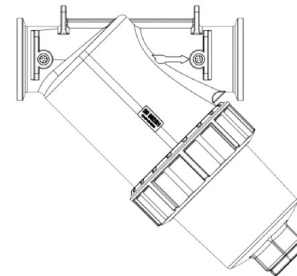

Figure 1

At the end of the season, thoroughly flush and clean the liquid system with hot soapy water.

Auger Gearcase

Drain oil in a new unit after first two weeks (or not more than 100 hours) of operation, and flush gear case thoroughly with light oil. Refer to "Lubricant and Hydraulic Oil Specifications" section for proper grade oil and recommended amounts of lubricant. After initial change, oil should be changed every 2,000 hours of operation or annually, whichever occurs first.

Check gearcase oil level monthly.

Sensors

Figure 5 - The EA2 utilizes sensors for spinner function:

- Spinner Speed (A)
- Spinner Down (B)

These sensors are installed and set at the factory. However, resetting will be required if related parts are replaced, or if control issues occur. To adjust, follow instructions below.

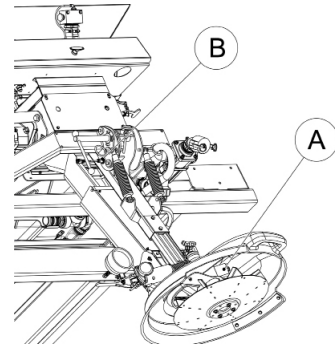

Figure 5

Spinner Speed Sensor

1. Remove spinner speed sensor assembly from spinner shaft.
2. Loosen set screw (A) to adjust spinner speed sensor.
3. Spinner speed sensor should protrude from mounting block (B) 0.630" (16mm).
4. Once sensor is properly set, tighten set screw.

NOTICE

Sensor must NOT come in contact with spinner shaft. Damage will occur if sensor contacts shaft.

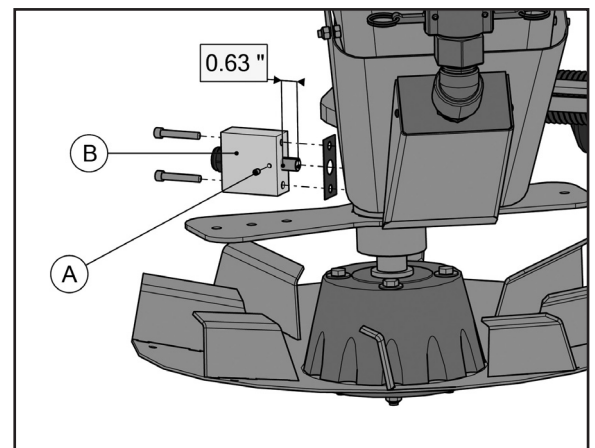

Figure 6

Spinner Up Sensor

1. Loosen sensor lock nuts.
2. Adjust sensor to obtain a 0.157" (4mm) gap between end of sensor and spinner assembly.
3. Once sensor is properly set, tighten lock nuts.

NOTICE

Sensor must NOT come in contact with spinner assembly. Damage will occur if sensor contacts mechanism.

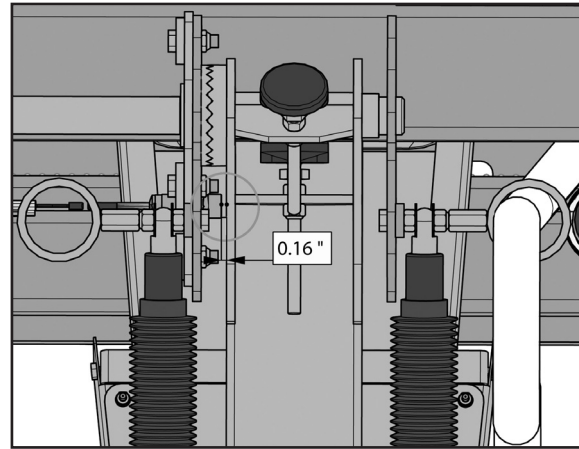

Figure 7

Lubrication of Bearings

Grease in a bearing acts to prevent excessive wear of parts, protects ball races, and balls from corrosion and aids in preventing excessive heat within the bearing. It is very important the grease maintain its proper consistency during operation. It must not be fluid and it must not channel.

Make sure all fittings are thoroughly cleaned before grease is injected. Points to be lubricated by means of a grease gun have standard grease fittings.

Lubricate bearings by pumping grease slowly until it forms a slight bead around the seals. This bead indicates adequate lubrication and also provides additional protection against the entrance of dirt.

Fasteners

Tighten all screws fasteners to recommended torques after first week of operation and annually thereafter. If loose fasteners are found at anytime, tighten to recommended torque. Replace any lost or damaged fasteners or other parts immediately. Check body mounting hardware every week.

Clean-Up

NOTICE

High pressure wash can inject water and/or fertilizer into control components, causing damage. Use caution when cleaning these areas.

Thoroughly wash unit every two to three days during the operating season to maintain minimal maintenance operation. Hose unit down under pressure to free all sticky and frozen material.

It is important the unit be thoroughly cleaned at the end of each operating season. All lubrication and maintenance instructions should be closely followed. Repaint worn spots to prevent formation of rust.



Hydraulic System

Use premium quality lubricants with 100-200 SUS or 20-43 cSt viscosity at operating temperatures. The hydraulic fluid's specifications in the table below are for normal operating conditions. Extreme environments or dirty conditions may require the use of different oils. Consult your New Leader dealer or the Product Support Department at Highway Equipment Company for systems operating outside normal conditions.

Ideal Oil Operating Temperature	115-158°F (46.11-70° C)
Recommended Premium Lubricant	Multi-Purpose Agriculture Hydraulic & Transmission Oil
Lubricant Specifications Viscosity Index Viscosity at 40°C, cst Viscosity at 100°C, cst	Greater than 130 Less than 68 Greater than 9
Acceptable Fluid Example	Mobil 424

Gearcase Lubricant

Lubricate these assemblies with non-corrosive type extreme pressure (E.P.) gear oil conforming to MIL-L2105 B multi-purpose gear lubricating oil requirements (API Service GL 4) based on ambient temperatures listed below. Refill gear case with one and a half (1-1/2) pints (.70 liters) of recommended lubricant.

Ambient Temperature	Below 40° (4.44°C)	Between 40° (4.44°C) and 100° (37.77°C)	Above 100° (37.77°C)
Oil Type	SAE 80 E.P.	SAE 90 E.P.	SAE 140 E.P.

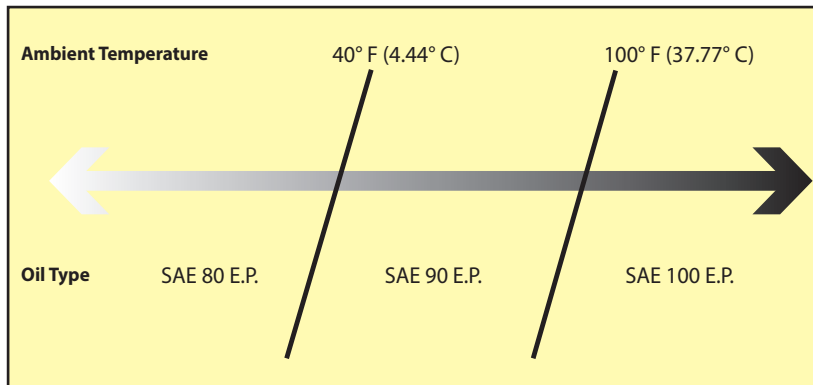

Grease Gun Lubricant

Use a waterproof ball and roller bearing lithium base lubricant with a minimum melting point of 300°F (148.8° C). This lubricant should have a viscosity which assures easy handling in the pressure gun at prevailing atmospheric temperatures. The grease should conform to NLGI No. 2 consistency.

⚠ WARNING

Shut off all power and allow all moving parts to come to rest before performing any maintenance operation. Failure to comply with this warning could result in death or serious injury.

The spreader should be regularly lubricated with the lubricants recommended in this manual in accordance with the following chart:

Location	Places	Method	Frequency
Auger			
Front Bearings	2	Grease Gun	Weekly
Gearcase	1	Gear Oil	Check Monthly; Change Annually
Spinner			
Spinner Assembly/Chute Pivot Shaft	1	Grease Gun	Weekly

NOTE: Unusual conditions, such as excessive dust, temperature extremes or excessive moisture may require more frequent lubrication of specific parts.

*See "Lubricant and Hydraulic Oil Specifications" for types of lubricants and oil to be used.



Lubrication Points

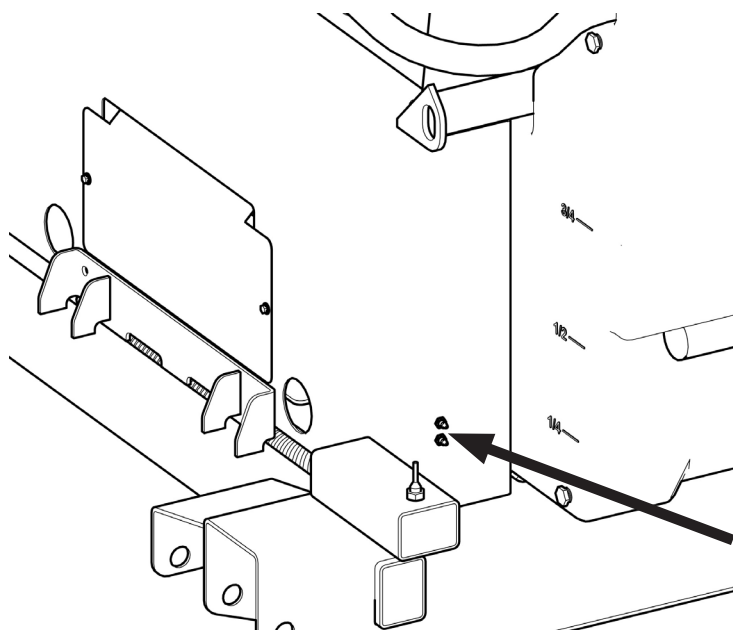
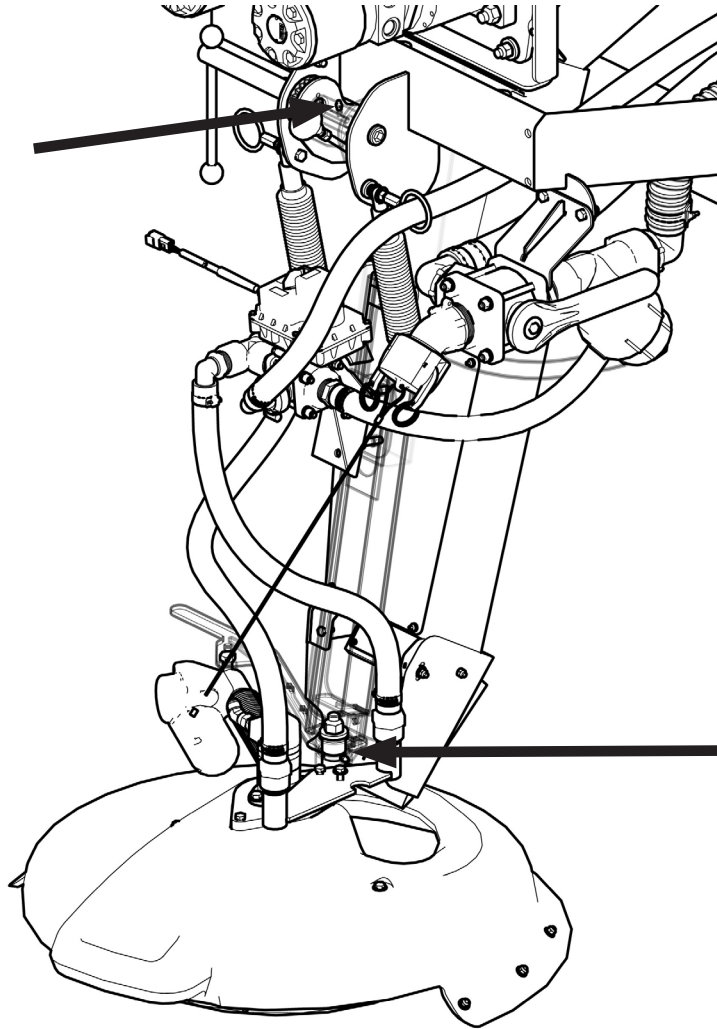

CAP SCREW GRADE IDENTIFICATION - MARKINGS ON HEAD

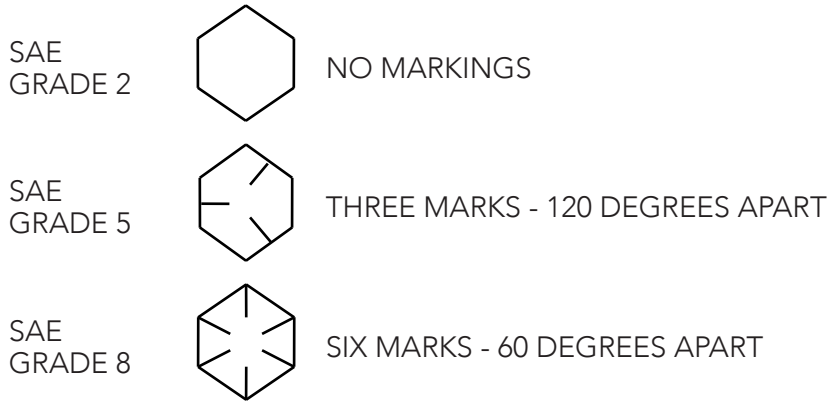

USE GRADE 2 TORQUES FOR STAINLESS STEEL FASTENERS AND CARRIAGE BOLTS.

CAP SCREW SIZE	TORQUE - FOOT-POUNDS					
	GRADE 2		GRADE 5		GRADE 8	
	DRY	LUBE	DRY	LUBE	DRY	LUBE
1/4"	5	4	8	6	12	9
5/16"	11	8	17	13	25	18
3/8"	20	15	30	23	45	35
7/16"	30	24	50	35	70	55
1/2"	50	35	75	55	110	80
9/16"	65	50	110	80	150	110
5/8"	90	70	150	110	220	170
3/4"	100	120	260	200	380	280
7/8"	140	110	400	300	600	460
1"	220	160	580	440	900	650

This page is intentionally left blank.

PARTS

Instructions For Ordering Parts



Order from the **AUTHORIZED DEALER** in your area.

1. Always give the pertinent model and serial number.
2. Give part name, part number and the quantity required.
3. Give the correct address to where the parts are to be shipped, and the carrier if there is a preference.

Unless claims for shortages or errors are made immediately upon receipt of goods they will not be considered. Any part returns should be directed through the dealer from which they were purchased.

When broken goods are received, a full description of the damage should be made by the carrier agent on the freight bill. If this description is insisted upon, full damage can always be collected from the transportation company.

No responsibility is assumed for delay or damage to merchandise while in transit. Our responsibility ceases upon delivery of shipment to the transportation company from whom a receipt is received showing that shipment was in good condition when delivered to them, therefore, claims (if any) should be filed with the transportation company and not with New Leader Manufacturing.

If your claims are not being handled (by the transportation company) to your satisfaction, please call our Product Sales & Support Department at New Leader Manufacturing at 888-363-8006 for assistance.

In the parts list the following symbols and abbreviations stand for:

* - Not Shown
 AR – As Required
 CS – Carbon Steel
 SS – Stainless Steel
 NS – Not Serviced

The parts listed under the different steel types (CS and 304 SS) are for that type of unit and do not necessarily mean the part is made of that type of steel.



Body

Screen

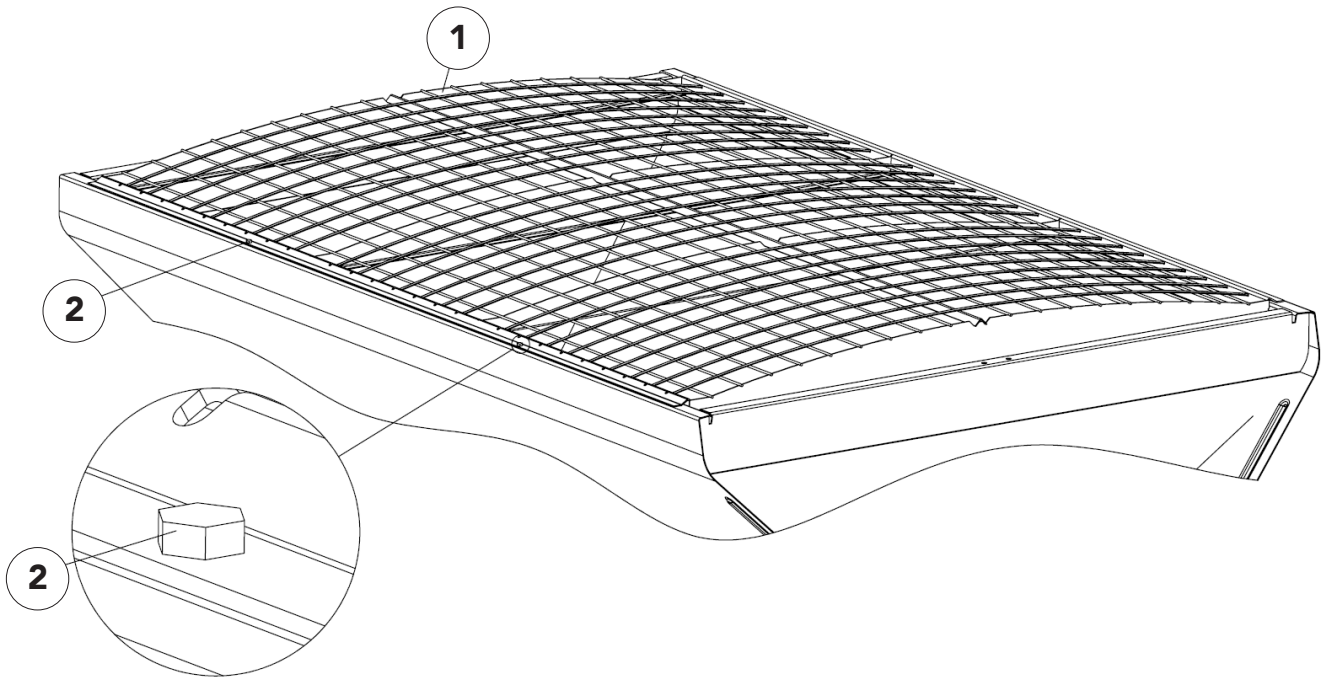

ITEM	PART NO.	DESCRIPTION	QTY
1	308228	Screen - 10' x 82" Galvanized	1
	308324	Screen - 12' X 82 Galvanized	1
	308325	Screen - 14' X 82 Galvanized	1
2	36293	Cap Screw - .375-16NC x .75 SS	AR

AR - As Required

Body

Rear Ladder

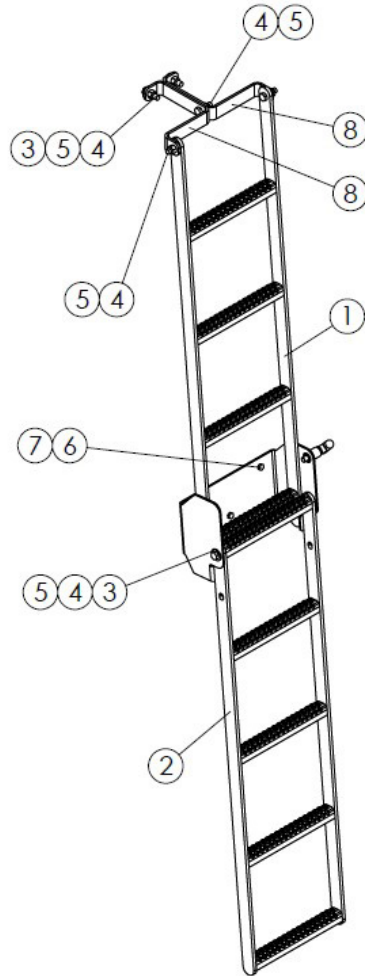

ITEM	PART NO.	DESCRIPTION	QTY
1	319165	Ladder - Wldmt Rear Upper 304	1
2	319166	Ladder - Wldmt Rear Lower 304	1
3	36426	Washer - Flat .5 SS	4
4	36539	Capscrew - .5-13nc X 1.5 SS	7
5	39016	Nut - Lock .5-13nc SS	7
6	36398	Capscrew - .375-16nc X 1 SS	3
7	36414	Nut - Hex .375-16nc SS	3
8	319171	Brace - Ladder 304	2



Body

Side Ladder

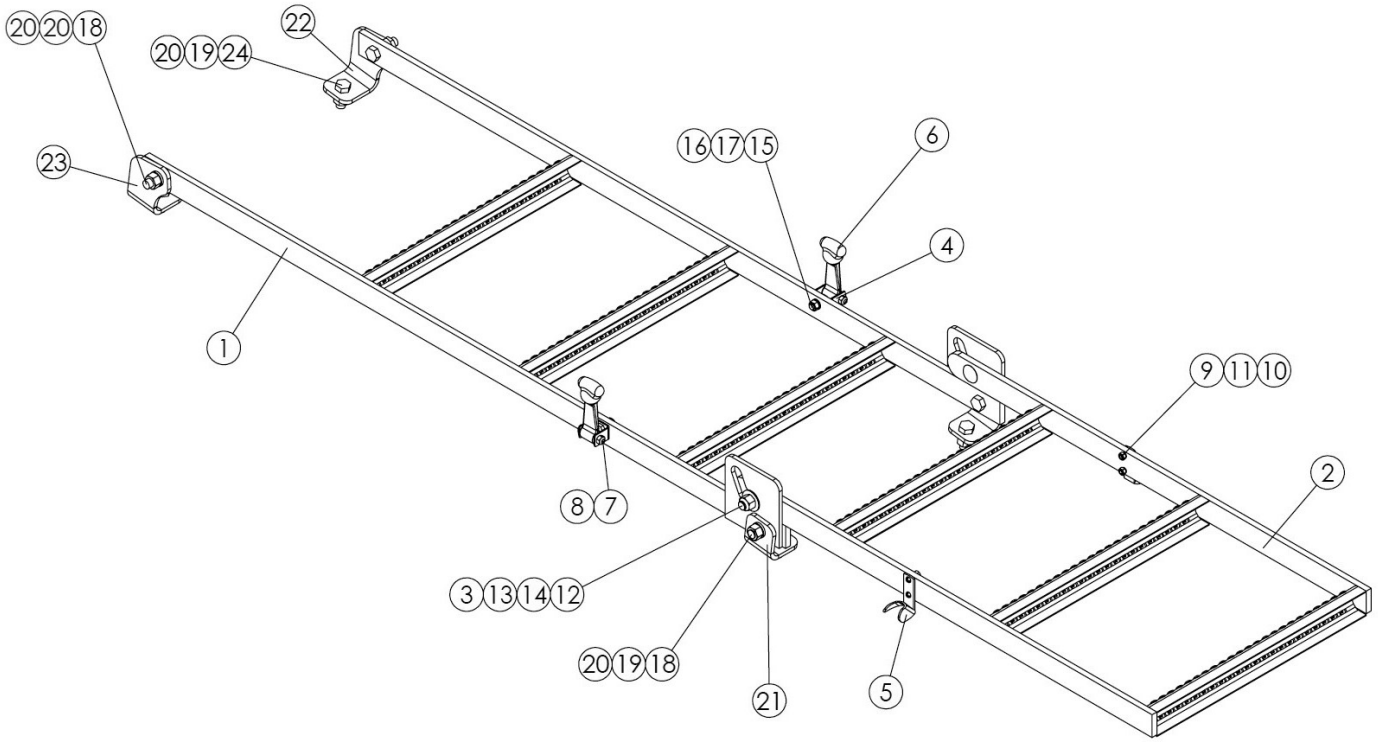

Body**Side Ladder**

<u>ITEM</u>	<u>PART NO.</u>	<u>DESCRIPTION</u>	<u>QTY</u>
1	319147	Ladder - Wldmt Side Upper 304	1
2	300456	Ladder - Wldmt Insp Lower 304	1
3	88638	Tube - .75od X .75 X .375 SS	2
4	73344	Bracket - Anchor	2
5	150043	Bracket - Hood	2
6	73343	Hook - Rubber	2
7	42448	Capscrew - .25-20nc X 1.5 SS	2
8	42034	Nut - Lock .25-20nc SS	2
9	44483	Screw - Round Head #10-24nc X .75 SS	4
10	44451	Washer - Lock #10 SS	4
11	47295	Nut - Hex #10-24nc SS	4
12	304484	Screw - Buttonhead .5-13NC X 1.5 SS	2
13	36426	Washer - Flat .5 SS	2
14	39016	Nut - Lock .5-13nc SS	2
15	300458	Capscrew - .313-18nc X .875 SS	2
16	36419	Washer - Lock .313 SS	2
17	36413	Nut - Hex .313-18nc SS	2
18	36539	Capscrew - .5-13nc X 1.5 SS	4
19	36422	Washer - Lock .5 SS	8
20	36416	Nut - Hex .5-13nc SS	8
21	318781	Bracket - Mount Ladder 304	2
22	318782	Bracket - Mount Ladder Rh 304	1
23	318783	Bracket - Mount Ladder Lh 304	1
24	36402	Capscrew - .5-13nc X 1.25 SS	4



Body

Side Ladder 12" Ext

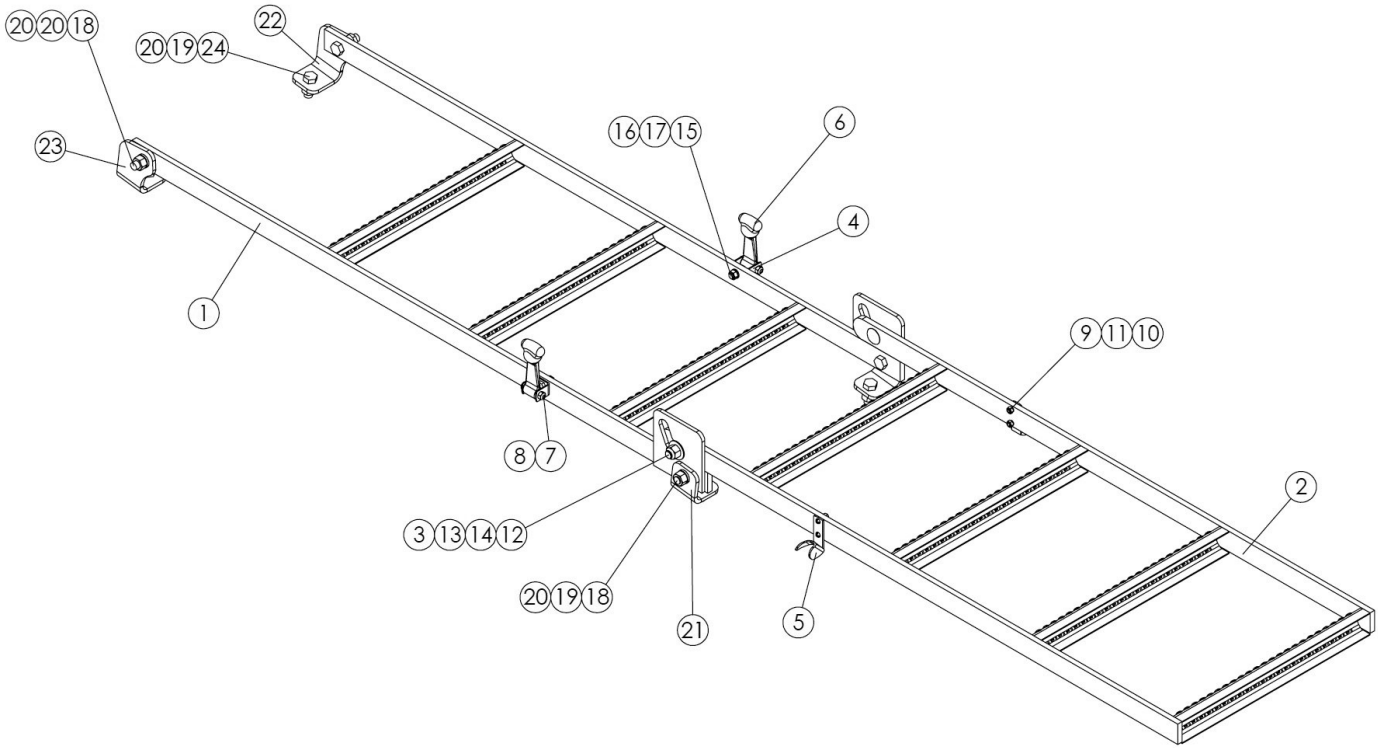

Body**Side Ladder 12" Ext**

<u>ITEM</u>	<u>PART NO.</u>	<u>DESCRIPTION</u>	<u>QTY</u>
1	319147	Ladder - Wldmt Side Upper 304	1
2	304096	Ladder - Wldmt Lower 44 304	1
3	88638	Tube - .75od X .75 X .375 SS	2
4	73344	Bracket - Anchor	2
5	150043	Bracket - Hood	2
6	73343	Hook - Rubber	2
7	42448	Capscrew - .25-20nc X 1.5 SS	2
8	42034	Nut - Lock .25-20nc SS	2
9	44483	Screw - Round Head #10-24nc X .75 SS	4
10	44451	Washer - Lock #10 SS	4
11	47295	Nut - Hex #10-24nc SS	4
12	304484	Screw- Buttonhead .5-13NC X 1.5 SS	2
13	36426	Washer - Flat .5 SS	2
14	39016	Nut - Lock .5-13nc SS	2
15	300458	Capscrew - .313-18nc X .875 SS	2
16	36419	Washer - Lock .313 SS	2
17	36413	Nut - Hex .313-18nc SS	2
18	36539	Capscrew - .5-13nc X 1.5 SS	4
19	36422	Washer - Lock .5 SS	8
20	36416	Nut - Hex .5-13nc SS	8
21	318781	Bracket - Mount Ladder 304	2
22	318782	Bracket - Mount Ladder Rh 304	1
23	318783	Bracket - Mount Ladder Lh 304	1
24	36402	Capscrew - .5-13nc X 1.25 SS	4



Body

Tarp

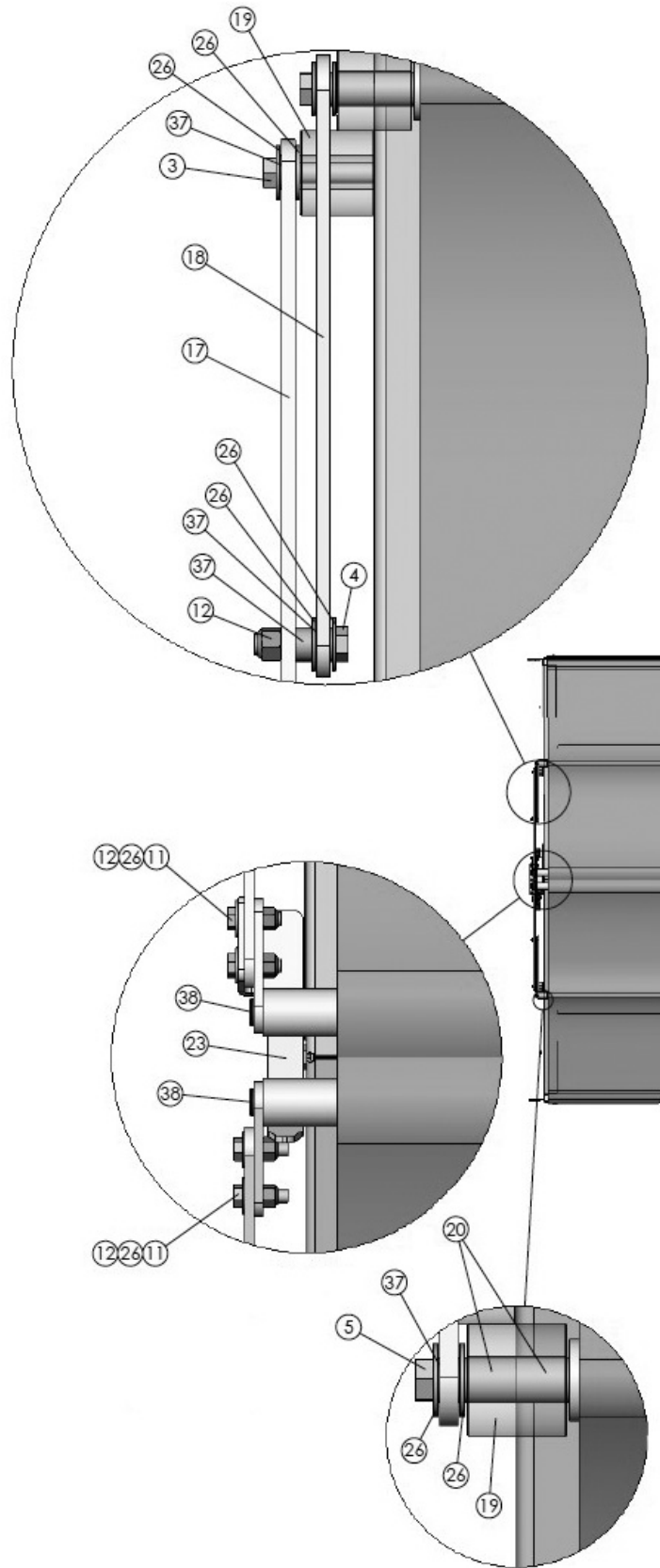

Body

Tarp

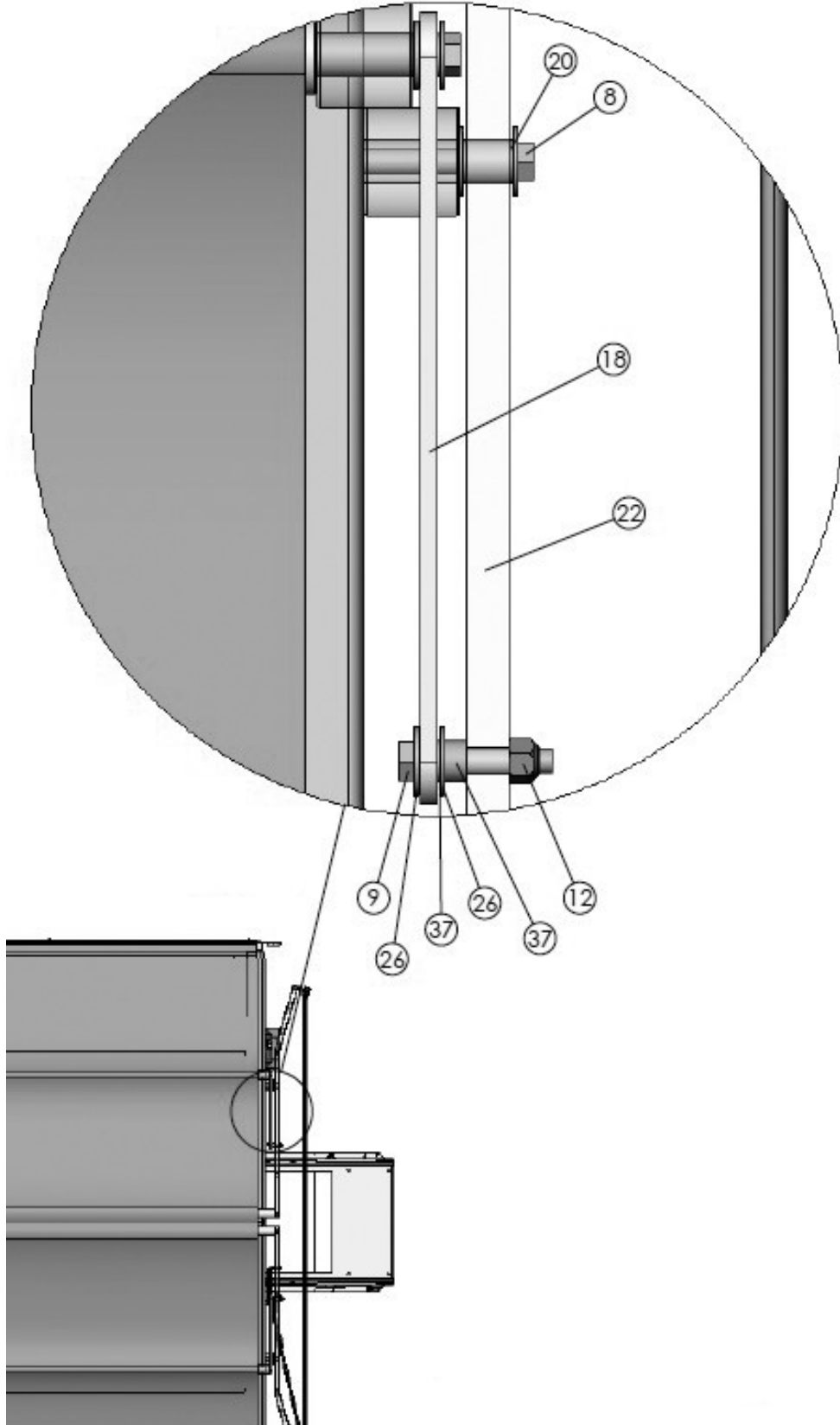

Body

Tarp

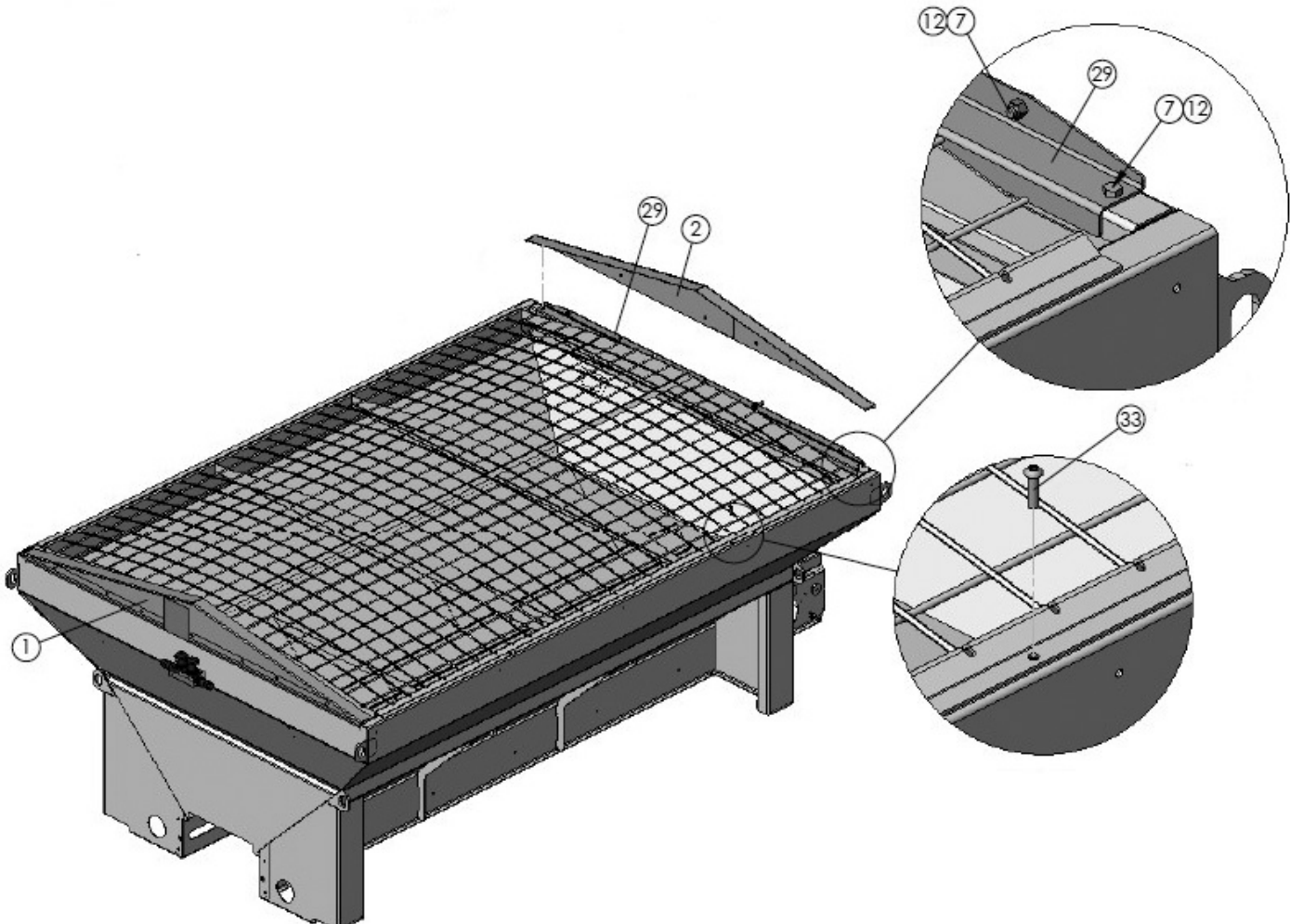
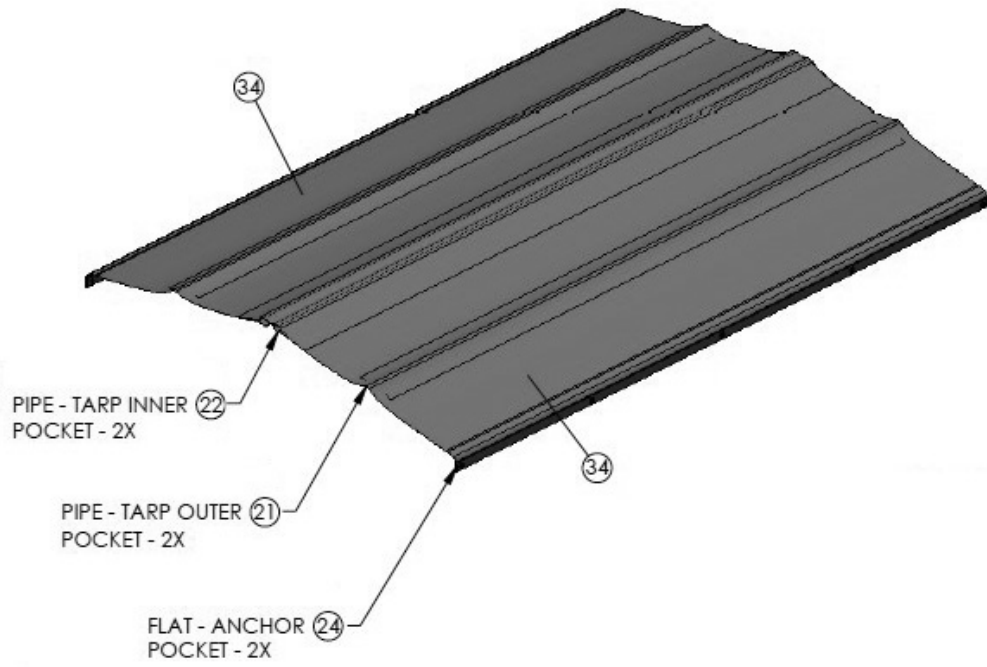

Body

Tarp

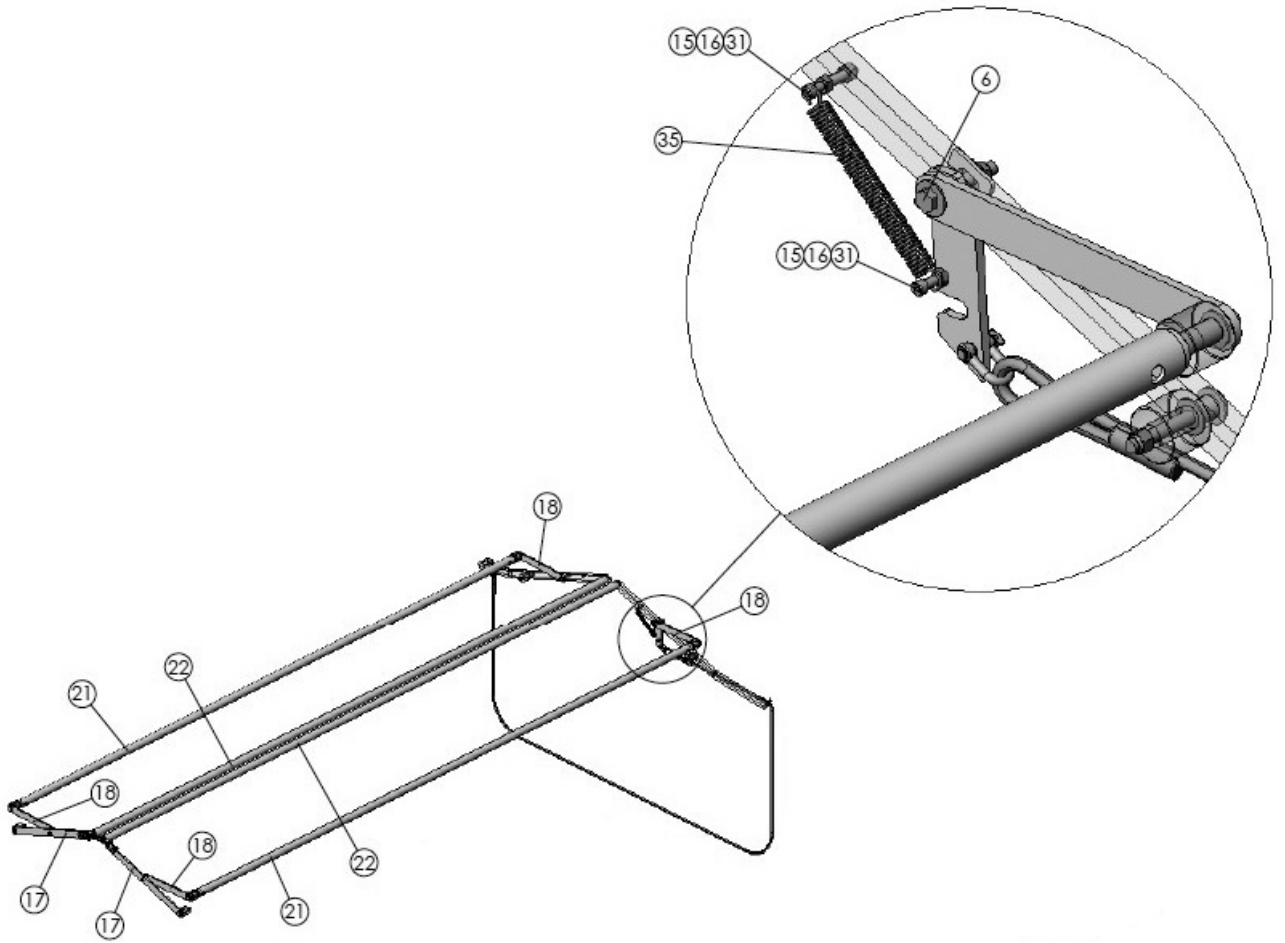

Body

Tarp

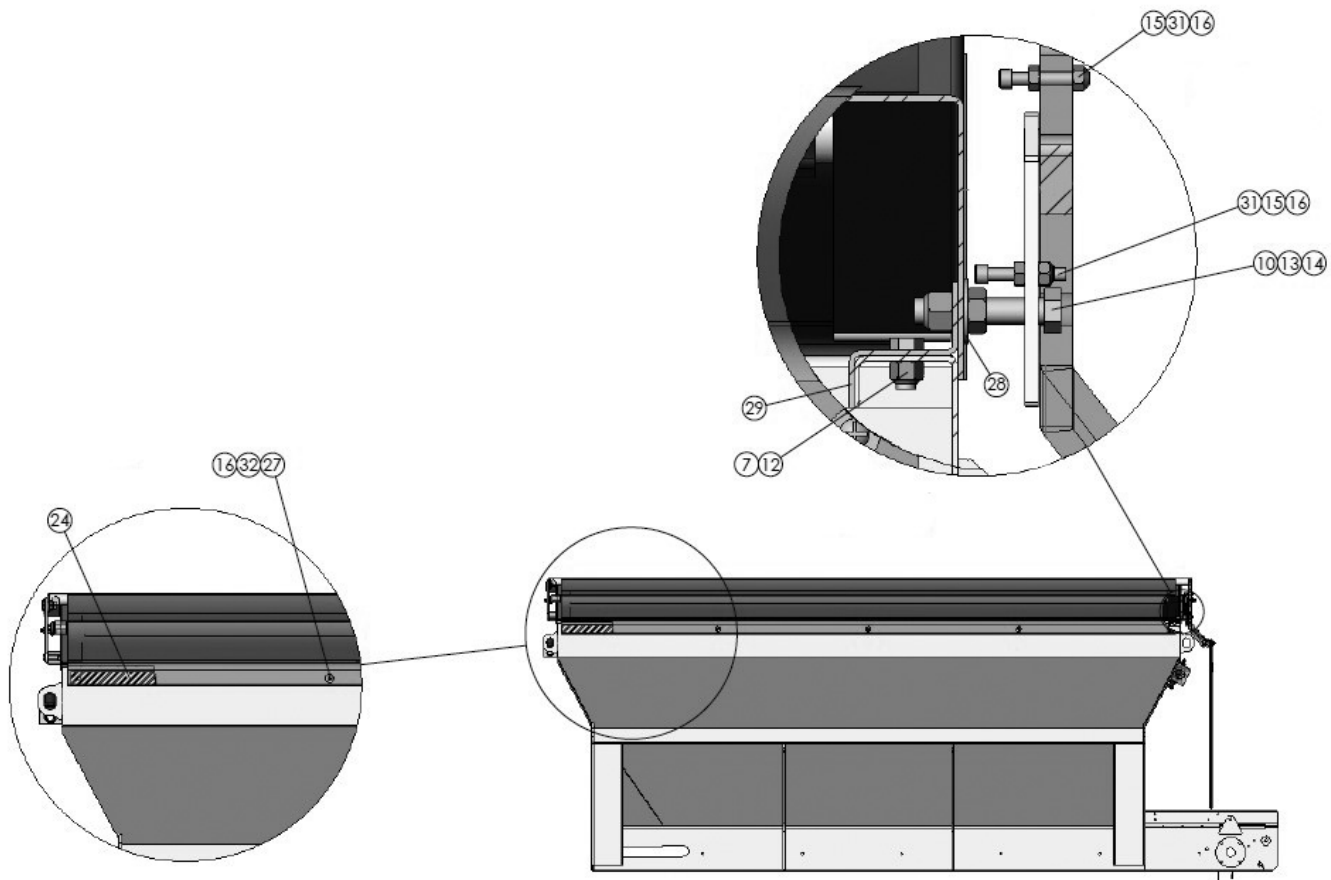

ITEM	PART NO.	DESCRIPTION	QTY
1	308407	Plate - Wldmt Tarp End Frnt	1
2	308408	Plate - Wldmt Tarp End Rear	1
3	36296	Capscrew - .3846 X 2.75 SS	2
4	34858	Capscrew - .375-16nc X 1.5 SS	2
5	36400	Capscrew - .375-16nc X 2.5 SS	4
6	71828	Capscrew - .375-16nc X 2.25 SS	1
7	36293	Capscrew - .375-16nc X .75 SS	14
8	71827	Capscrew - .375-16nc X 3 SS	2
9	34859	Capscrew - .375-16nc X 2 SS	1
10	42454	Capscrew - .5-13nc X 2.5 SS	1
11	36399	Capscrew - .375-16nc X 1.25 SS	4



Body**Tarp**

<u>ITEM</u>	<u>PART NO.</u>	<u>DESCRIPTION</u>	<u>QTY</u>
12	72054	Nut - Lock .375-16nc SS	26
13	36416	Nut - Hex .5-13nc SS	1
14	39016	Nut - Lock .5-13nc SS	1
15	42034	Nut - Lock .25-20nc SS	2
16	36412	Nut - Hex .25-20nc SS	12
17	309504	Linkage - Tarp Long Galv	2
18	309505	Linkage - Tarp Short Galv	4
19	308398	Roller - Tarp	8
20	308401	Spacer - .625od X .385id X .719 304	10
21	309501	Pipe - Tarp Outer 10' Galv	2
22	309498	Pipe - Tarp Inner 10' Galv	2
23	309506	Lock - Tarp Front Galvanized	1
24	309508	Flat - Anchor Tarp 10' Galv	2
25	309507	Lock - Tarp Rear Galvanized	1
26	36425	Washer - Flat .375 SS	29
27	21423-X1	Washer - Flat .25 Special SS	10
28	36426	Washer - Flat .5 SS	1
29	308404	Angle - Mounting Plate End 304	2
30	309497	Stop - Lock Galvanized	1
31	308047	Capscrew - .25-20nc X 1.5 SS	2
32	42033	Screw - Truss Head .25-20nc X 1 SS	10
33	71772	Screw - Buttonhead .375-16nc X 1.25 SS	2
34	308409	Tarp - 10'	2
	308373	Tarp - 12'	2
	308422	Tarp - 14'	2
35	308411	Spring - .625od X .4 X .063 SS	1
36	308412	Shackle - D .25 X .313 X .875	2
37	88050	Spacer - Dump Over Chute 304	14
38	308406	Plug - Plastic .75	4
39	308400	Rope - Tarp	1



Body

Spill Shield

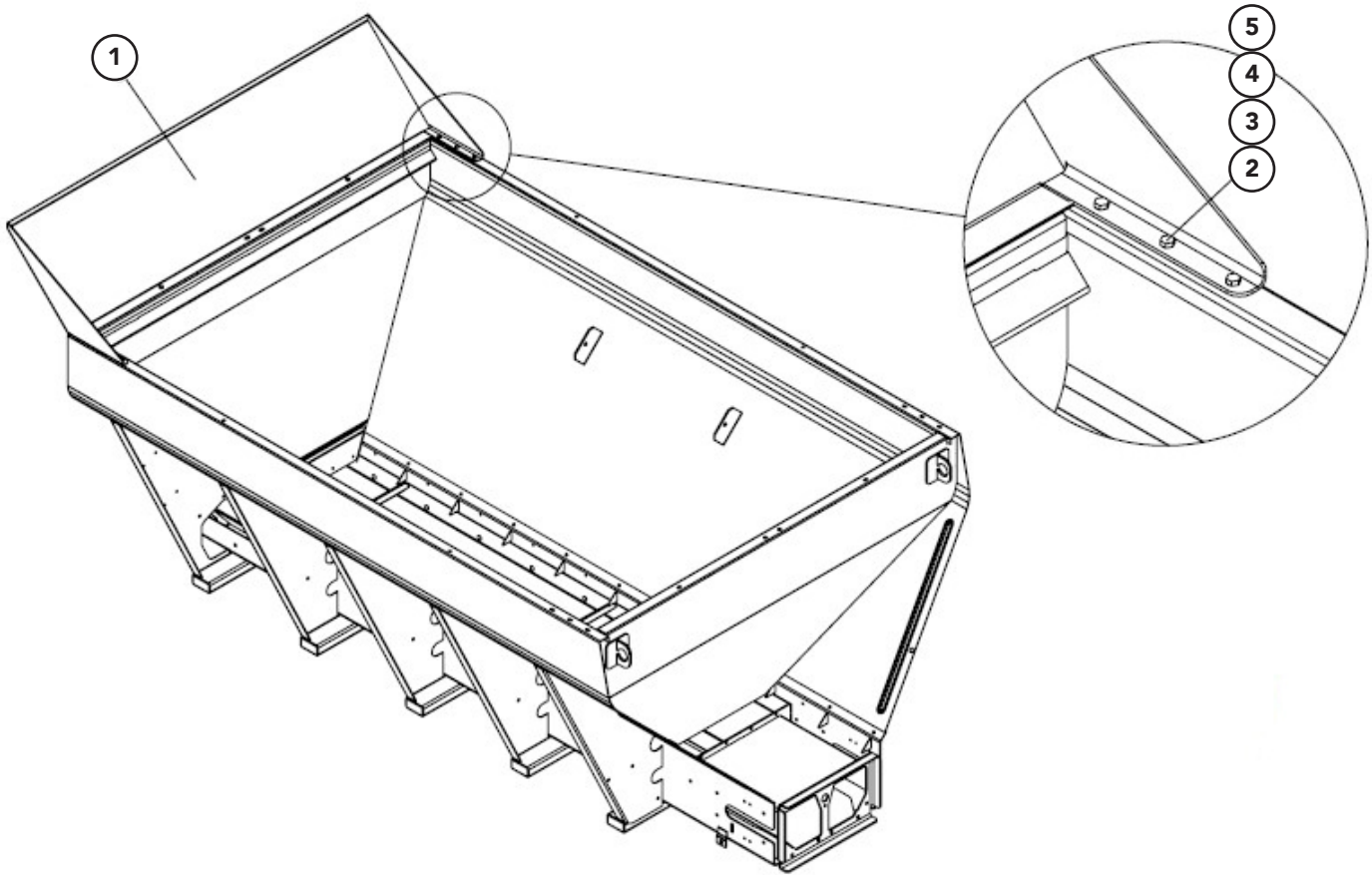

Body**Spill Shield**

<u>ITEM</u>	<u>PART NO.</u>	<u>DESCRIPTION</u>	<u>QTY</u>
1	318715	Shield - Wldmt Spill 304	1
2	36398	Capscrew - .375-16nc X 1 SS	8
3	36420	Washer - Lock .375 SS	8
4	36414	Nut - Hex .375-16nc SS	8
5	36425	Washer - Flat .375 SS	8



Body

Cab Shield

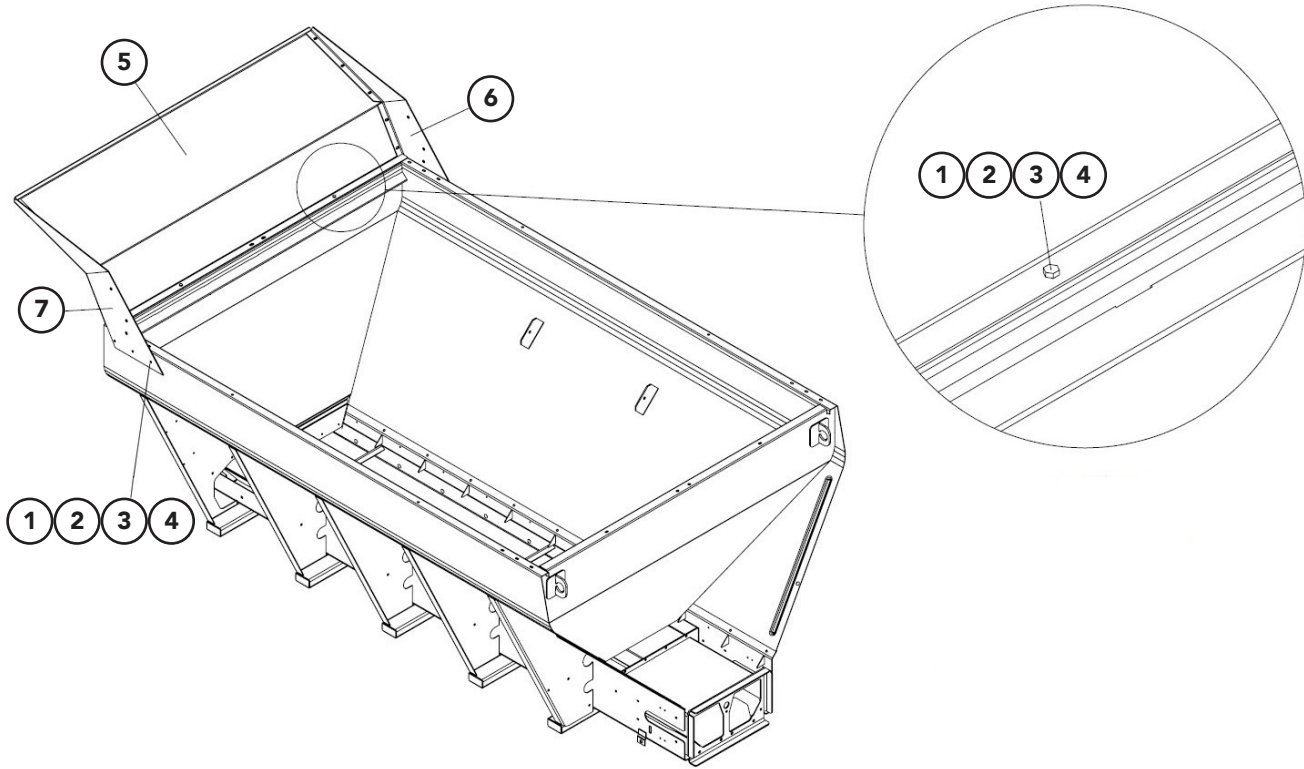

Body**Cab Shield**

<u>ITEM</u>	<u>PART NO.</u>	<u>DESCRIPTION</u>	<u>QTY</u>
1	36398	Cap Screw – 3/8 x 1	AR
2	36425	Washer – Flat 3/8	AR
3	36420	Washer – Lock 3/8	AR
4	36414	Nut – Hex 3/8	AR
5	318776	Panel – Shield 57" Cab Height	1
-	318777	Panel – Shield 63" Cab Height	1
-	318778	Panel – Shield 69" Cab Height	1
6	79170	Support – RH 57" Cab Height	1
-	79174	Support – RH 63" Cab Height	1
-	79178	Support – RH 69" Cab Height	1
7	79172	Support – LH 57" Cab Height	1
-	79176	Support – LH 63" Cab Height	1
-	79180	Support – LH 69" Cab Height	1



Truck Chassis Mount

Subframe

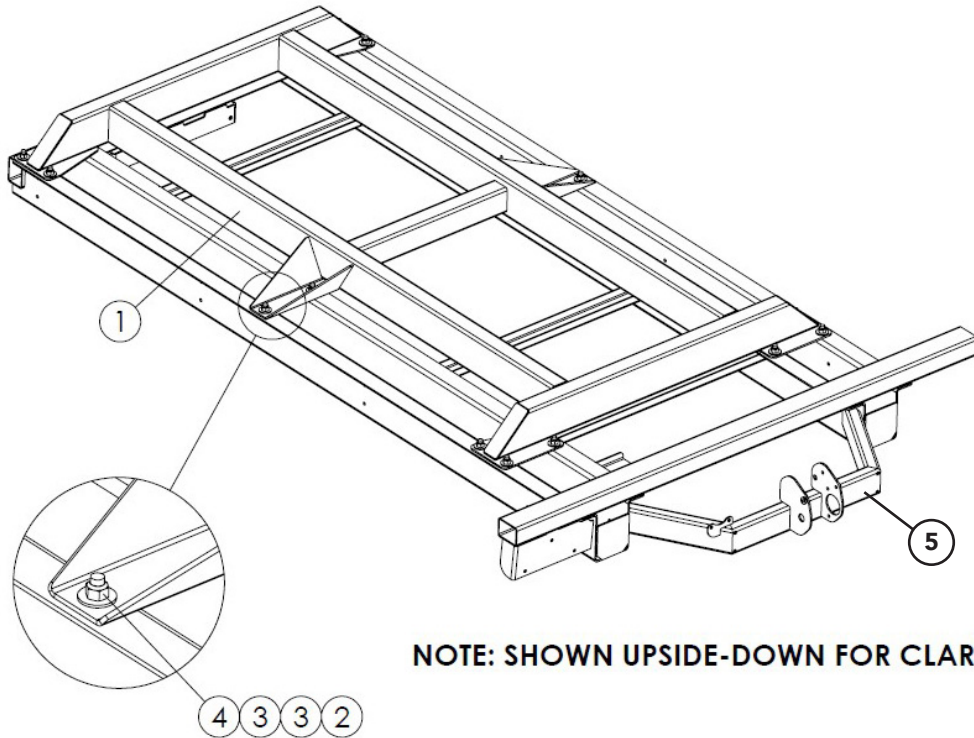

NOTE: SHOWN UPSIDE-DOWN FOR CLARITY

ITEM	PART NO.	DESCRIPTION	QTY
1	309487	Frame - Wldmt Tcmt 10'	1
	309482	Frame - Wldmt Tcmt 12'	1
	309466	Frame - Wldmt Tcmt 14'	1
2	20176	Capscrew - .625-11nc X 1.75	AR
3	20697	Washer - Flat .625 Zn	AR
4	20682	Nut - Lock .625-11nc Zn	AR
5	319158	Subframe - Galvanized TCMT 10'	1
	319160	Subframe - Galvanized TCMT 12'	1
	319162	Subframe - Galvanized TCMT 14'	1

AR - As Required

Truck Chassis Mount

Mount Kit

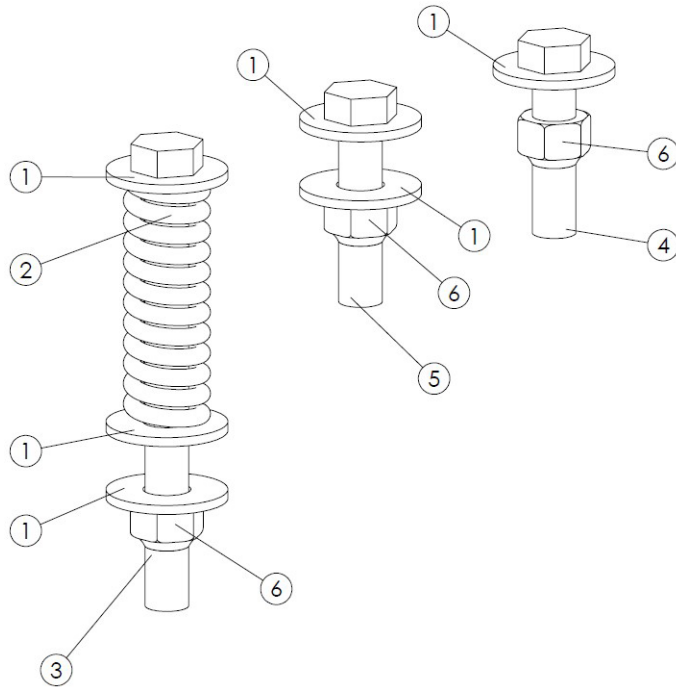
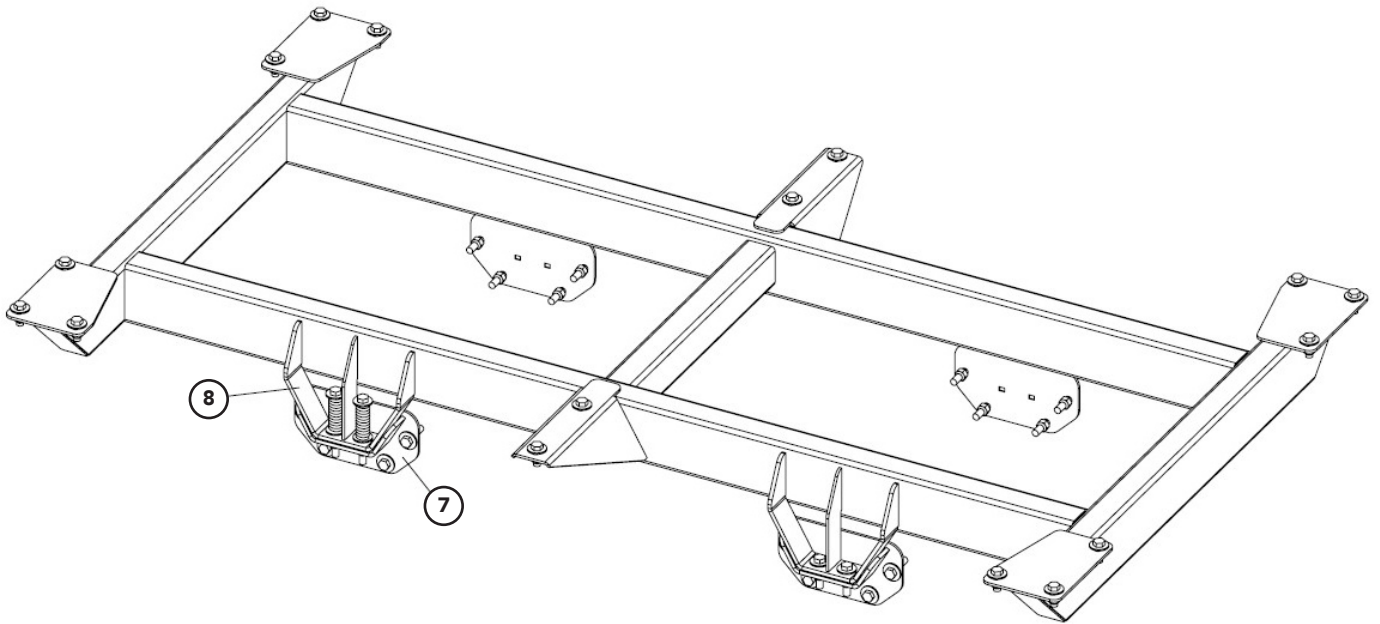

Truck Chassis Mount

Mount Kit

ITEM	PART NO.	DESCRIPTION	QTY		
			10'	12'	14'
1	20697	Washer - Flat .625 Zn	52	52	52
2	81000	Spring - Compression	4	4	4
3	20195	Capscrew - .625-11nc X 6.5 Gr5	4	4	4
4	20179	Capscrew - .625-11nc X 2.5 Gr5	24	24	24
5	20180	Capscrew - .625-11nc X 2.75	8	8	8
6	20682	Nut - Lock .625-11nc Zn	36	36	36
7	316963	Mount - Wldmt Chassis	4	6	6
8	316964	Tiedown - Wldmt Mount	4	6	6



Truck Chassis Mount

Fenders

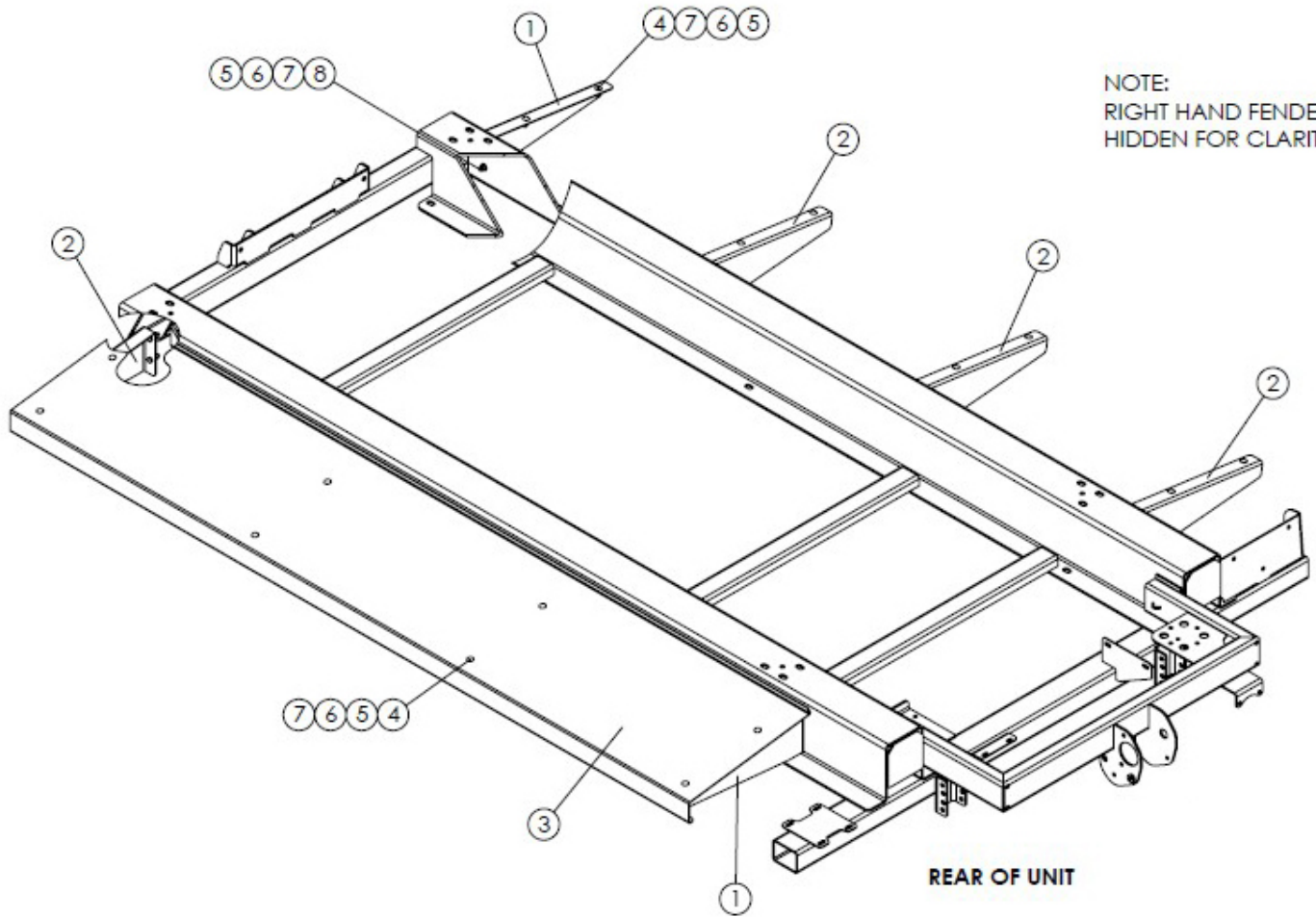

NOTE:
RIGHT HAND FENDER
HIDDEN FOR CLARITY

ITEM	PART NO.	DESCRIPTION	QTY		
			10'	12'	14'
1	309470	Bracket - Fender Rh 201	4	5	5
2	309471	Bracket - Fender Lh 201	4	5	5
3	319142	Fender - Panel 10' 201	2		
	319143	Fender - Panel 12' 201		2	
	319144	Fender - Panel 14' 201			2
4	36408	Bolt - Carriage .375-16nc X 1	16	20	20
5	36425	Washer - Flat .375 SS	48	60	60
6	36420	Washer - Lock .375 SS	32	40	40
7	36414	Nut - Hex .375-16nc SS	32	40	40
8	36399	Capscrew - .375-16nc X 1.25 SS	16	20	20
9	*39200	Decal - Warning Slippinghazard	2	2	2

* Not Shown



Dump Body Mount

Subframe

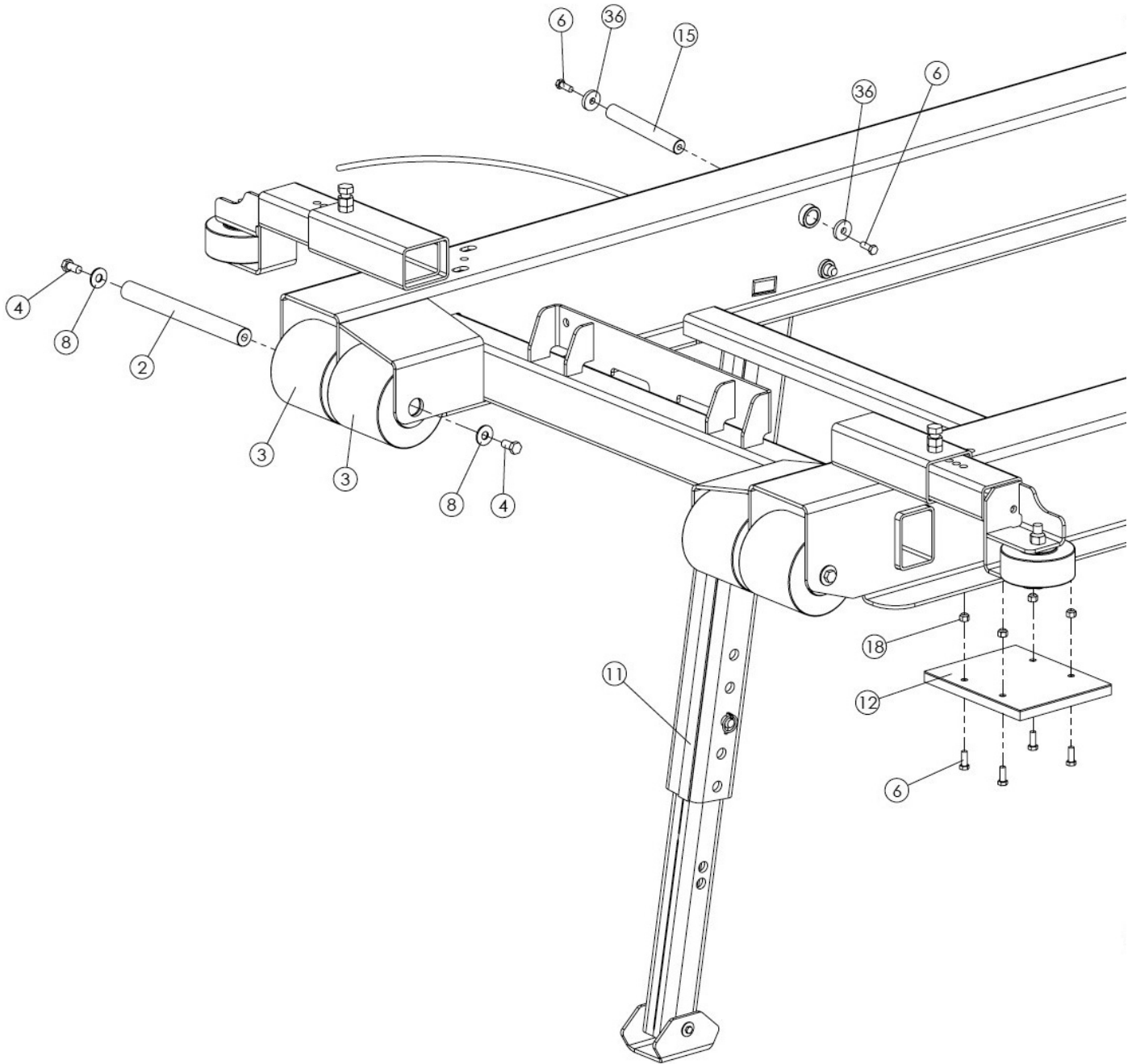

Dump Body Mount

Subframe

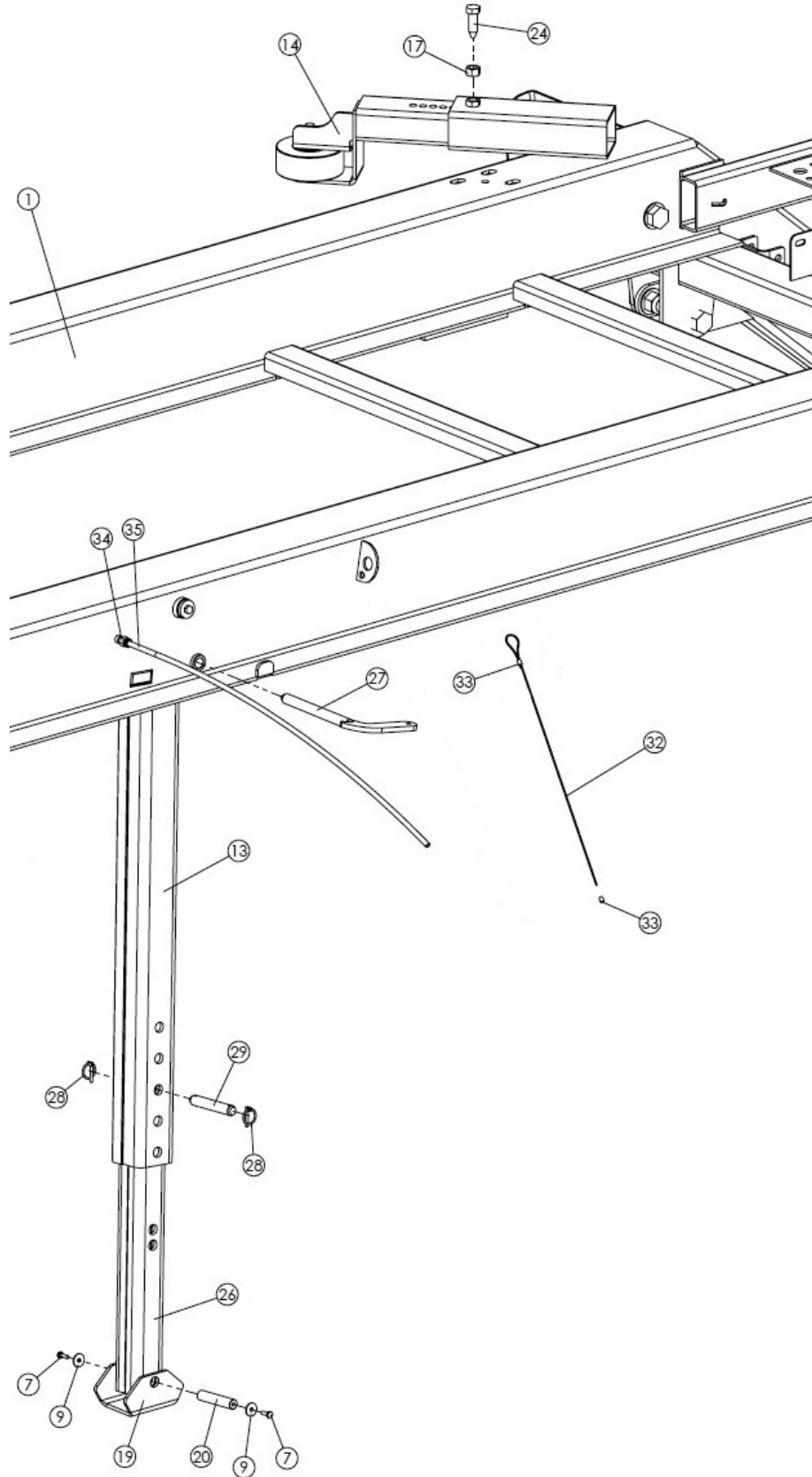

Dump Body Mount

Subframe

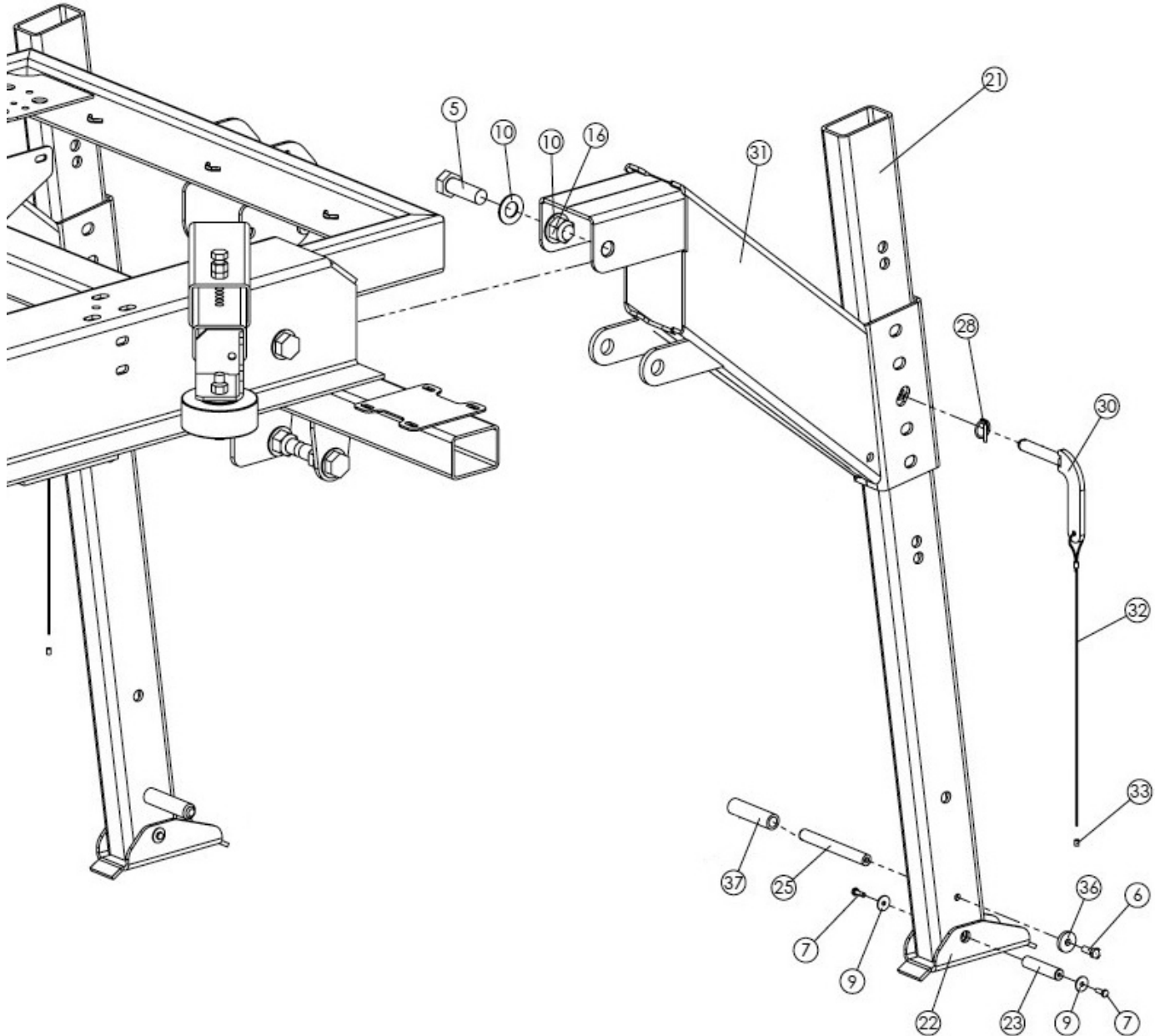

ITEM	PART NO.	DESCRIPTION	QTY
1	319150	Subframe - Galvanized 10'	1
	319153	Subframe - Galvanized 12'	1
	319156	Subframe - Galvanized 14'	1
2	307790	Axle - Wheel Sub-Frame 304	2
3	307764	Wheel - Mount Roll-On	4
4	36401	Capscrew - .5-13nc X 1 SS	4
5	308086	Capscrew - 1-8nc X 2.5 SS	8



Dump Body Mount**Subframe**

<u>ITEM</u>	<u>PART NO.</u>	<u>DESCRIPTION</u>	<u>QTY</u>
6	36398	Capscrew - .375-16nc X 1 SS	22
7	36393	Capscrew - .25-20nc X .75 SS	8
8	308089	Washer - Uss .5 X 1.375 Galv	4
9	308088	Washer - Fender .25 X 1 Galv	8
10	20700-X1	Washer - Flat 1 SS	16
11	308079	Leg - Assy Front Rh	1
12	307794	Pad - Mount Rubber	4
13	308078	Leg - Assy Front Lh	1
14	307766	Wheel - Assy Guide	4
15	307808	Pin - Hinge Leg 304	2
16	308087	Nut - Lock 1-8nc SS	8
17	36417	Nut - Hex .625-11nc SS	4
18	72054	Nut - Lock .375-16nc SS	16
19	308074	Foot - Front Galvanize	2
20	307809	Pin - Hinge Foot Front 304	2
21	308073	Leg - Rear Galvanized	2
22	308075	Foot - Rear Galvanized	2
23	307824	Pin - Hinge Rear Foot 304	2
24	307997	Capscrew - .625-11nc X 2 SS	4
25	308001	Handle - Leg 304	2
26	308072	Leg - Front Galvanized	2
27	308076	Pin - Lock Zinc Plated	2
28	308053	Pin - Lynch .188 X 1.25	6
29	308037	Pin - Leg Front Adjustment 304	2
30	308077	Pin - Rear Leg Zinc Plated	2
31	308069	Transition - Galvanize	2
32	308084	Cable - .094 X 24 Coated	4
33	308085	Ferrule - .185 X .374	8
34	9005-0-7818	Fitting - 6-2 630102b	2
35	9005-0-7797	Tube - .375od Air Brake Blue	6
36	307746	Spacer - .438id X .25 304	6
37	308246	Handgrip - Foam Tube	2



Dump Body Mount

Mount Kit

<u>ITEM</u>	<u>PART NO.</u>	<u>DESCRIPTION</u>	<u>QTY</u>
1	308215	Strap - Ratchet	4

This page is intentionally left blank.

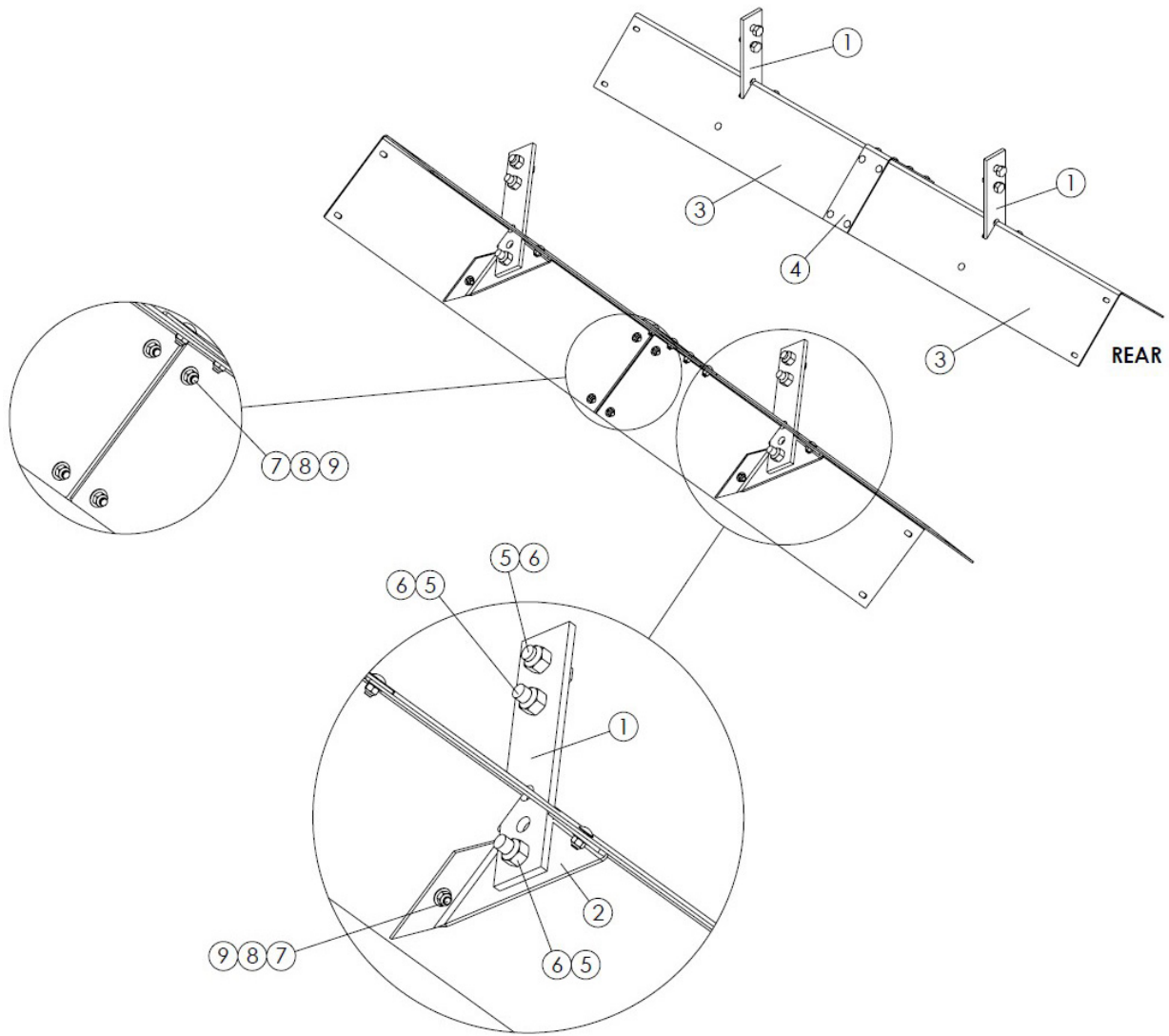

Inverted V-Assembly

ITEM	PART NO.	DESCRIPTION	QTY		
			10'	12'	14'
1	319217	Bar - Mounting 304	2	2	3
2	302371	Bracket - V Bolt-On 304	2	2	3
3	319214	V - Inverted 32.25 304 10'	2	-	-
	319215	V - Inverted 40.25 304 12'	-	2	-
	319216	V - Inverted 36 304 14'	-	-	3
4	319218	Angle - Splice 304	1	1	2
5	58800	Capscrew - .625-11nc X 1.75 SS	6	6	9
6	41762	Nut - Lock .625-11nc SS	6	6	9
7	96880	Bolt - Carriage .313-18nc X .75 SS	12	12	22
8	36424	Washer - Flat .313 SS	12	12	22
9	42221	Nut - Lock .313-18nc SS	12	12	22



Spinner

Spinner Pivot

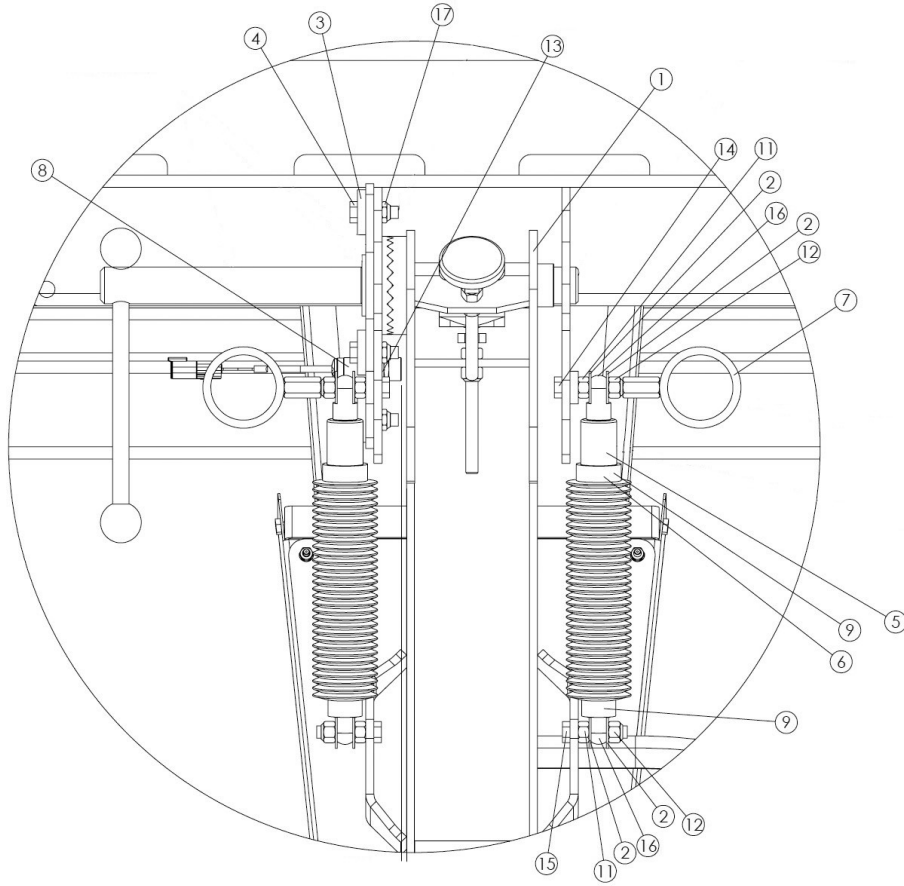

Spinner**Spinner Pivot**

<u>ITEM</u>	<u>PART NO.</u>	<u>DESCRIPTION</u>	<u>QTY</u>
1	316778	Spinner- Assy	1
2	36425	Washer- Flat .375 SS	8
3	307746	Spacer- .438id X .25 304	3
4	36399	Capscrew- .375-16nc X 1.25 SS	3
5	307972	Spring- Gas	2
6	307969	Bellows- Rod	2
7	307984	Ring- Wldmt 304	2
8	308179	Sensor- 18mm W/Dtm04-3p 57	1
9	99674	Strap- Zip Tie 8 Black	4
10	*301315	Loctite- 243	0
11	36414	Nut- Hex .375-16nc SS	4
12	72054	Nut- Lock .375-16nc SS	4
13	308237	Washer- Star Internal 18mm SS	2
14	308224	Capscrew- .375-16nc X 2.5 Gr8	2
15	308225	Capscrew- .375-16nc X 1.75	2
16	308315	Rod- End 304	4
17	307395	Nut- Lock Thin .375-16nc SS	3

* Not Shown



Spinner

Spinner Assembly

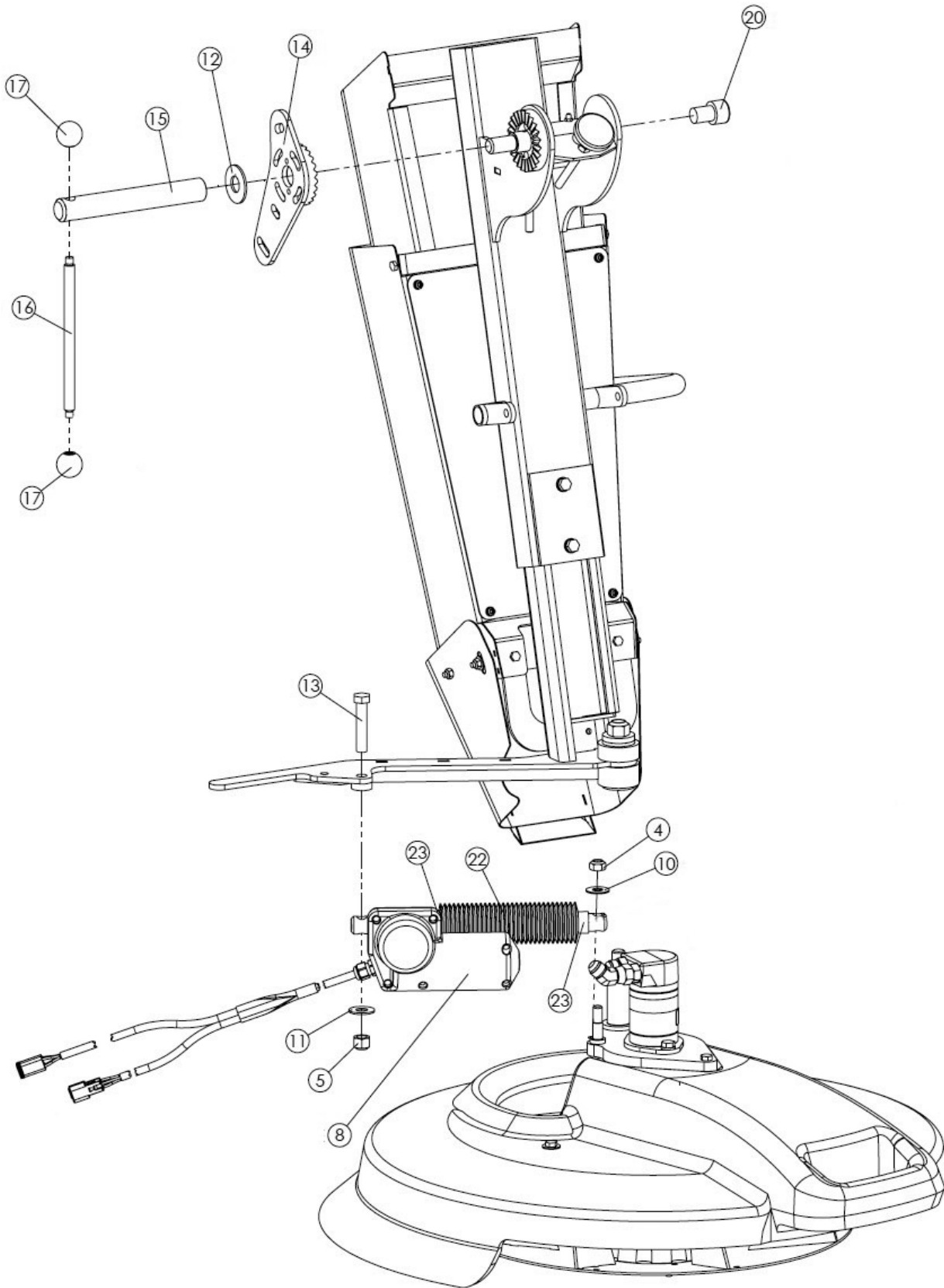

Spinner

Spinner Assembly

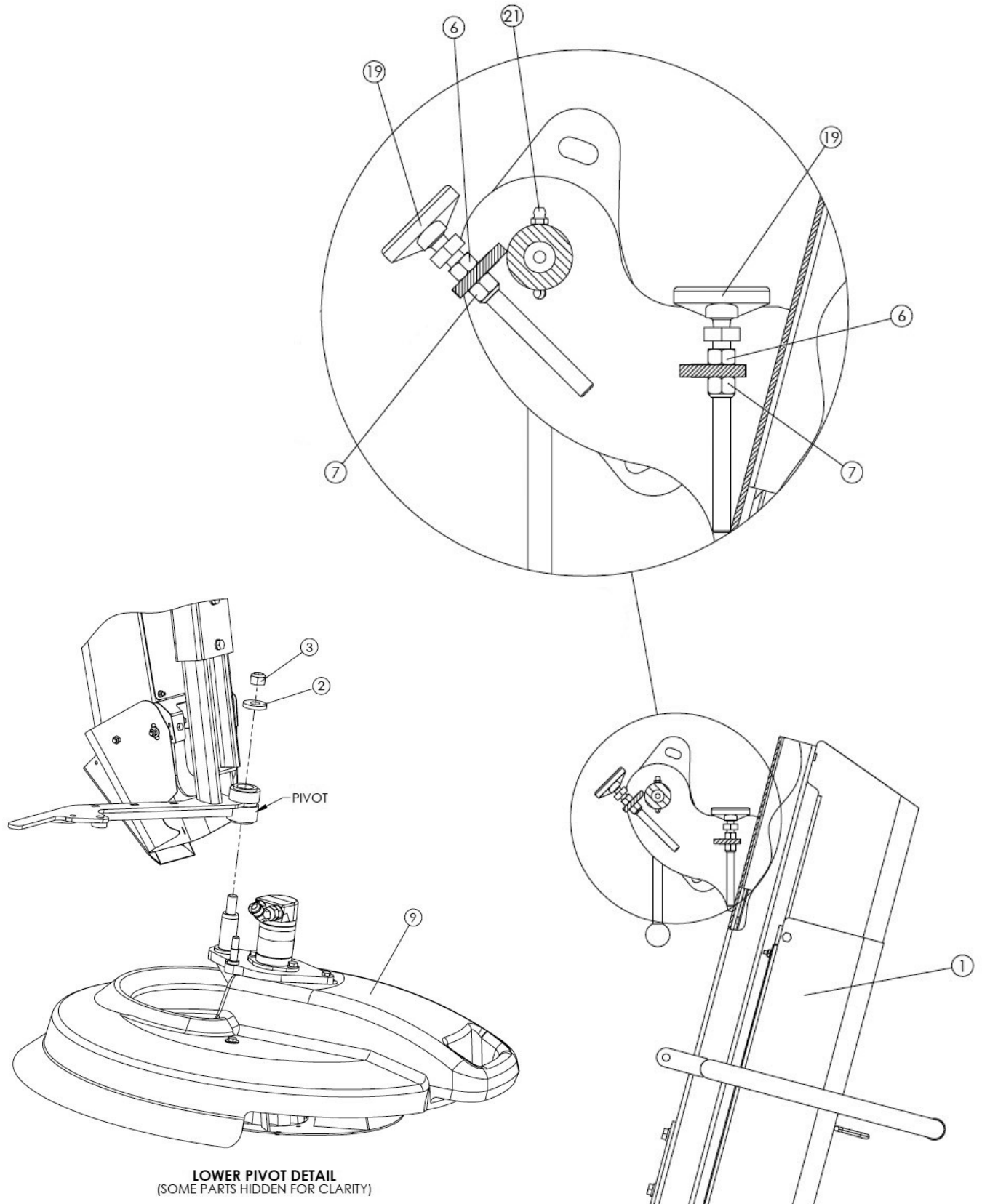

LOWER PIVOT DETAIL
(SOME PARTS HIDDEN FOR CLARITY)



Spinner

Spinner Assembly

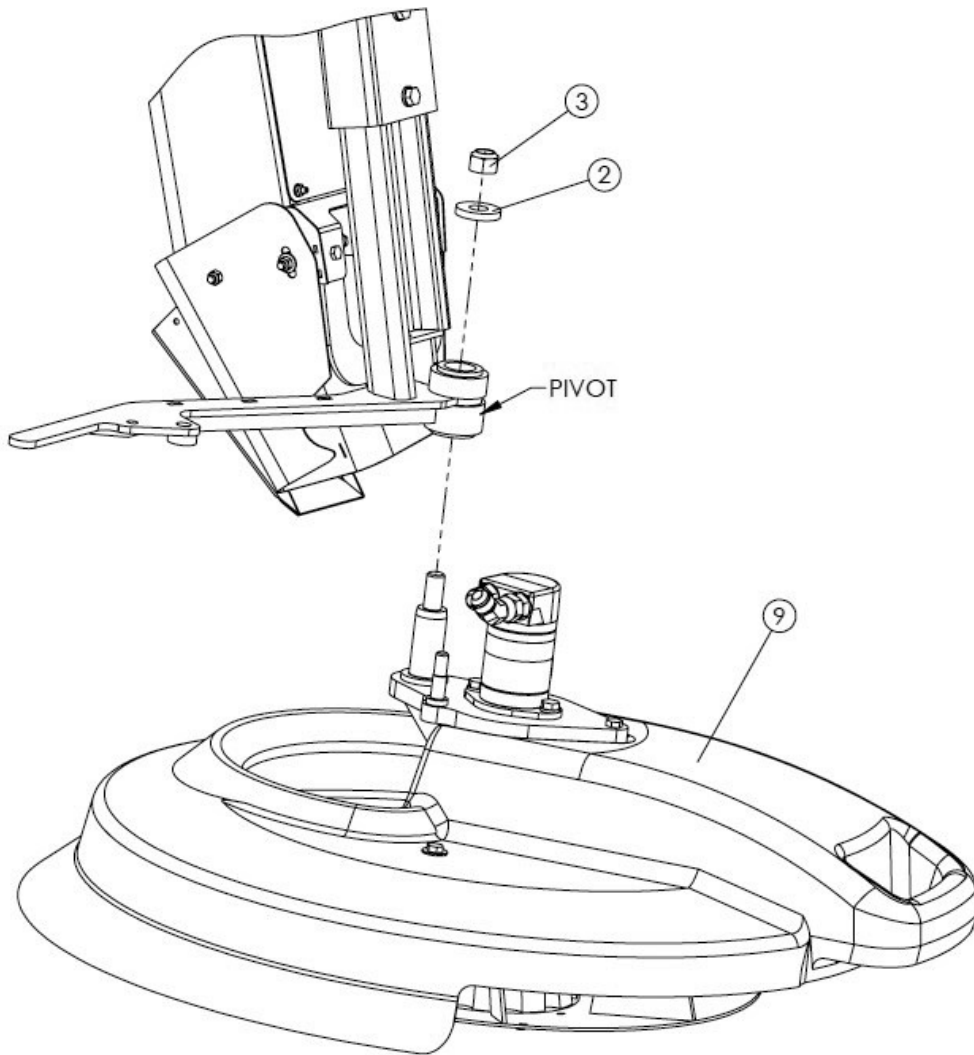

Spinner**Spinner Assembly**

<u>ITEM</u>	<u>PART NO.</u>	<u>DESCRIPTION</u>	<u>QTY</u>
1	316779	Chute - Assy 304	1
2	307935	Washer - 1.563OD X .656ID X .250 304	1
3	41762	Nut - Lock .625-11NC SS	1
4	307987	Nut - Lock .438-20NF SS	1
5	39016	Nut - Lock .5-13NC SS	1
6	36414	Nut - Hex .375-16NC SS	2
7	72054	Nut - Lock .375-16NC SS	2
8	310168	Actuator - Linear Electric	1
9	307861	Spinner - Assy Lower	1
10	36295	Washer - Flat .438 SS	1
11	36426	Washer - Flat .5 SS	1
12	56408	Washer - Flat .75 SS	1
13	42454	Capscrew - .5-13NC X 2.5 SS	1
14	316786	Lock - Wldmt Chute 304	1
15	307916	Bar - Chute Rotation Lock 304	1
16	307917	Handle - 304	1
17	307918	Knob - 1.25	2
18	307953	Grip - Round Vinyl	1
19	307973	Foot - Leveling Swivel SS	2
20	307920	Screw - Socket Hd .75-10NC X 1	1
21	6072	Zerk - Grease 1/4-28Nf Strght	1
22	307969	Bellows - Rod	1
23	99674	Tie - Zip 8" Black	2



Spinner

Lower Spinner Assembly

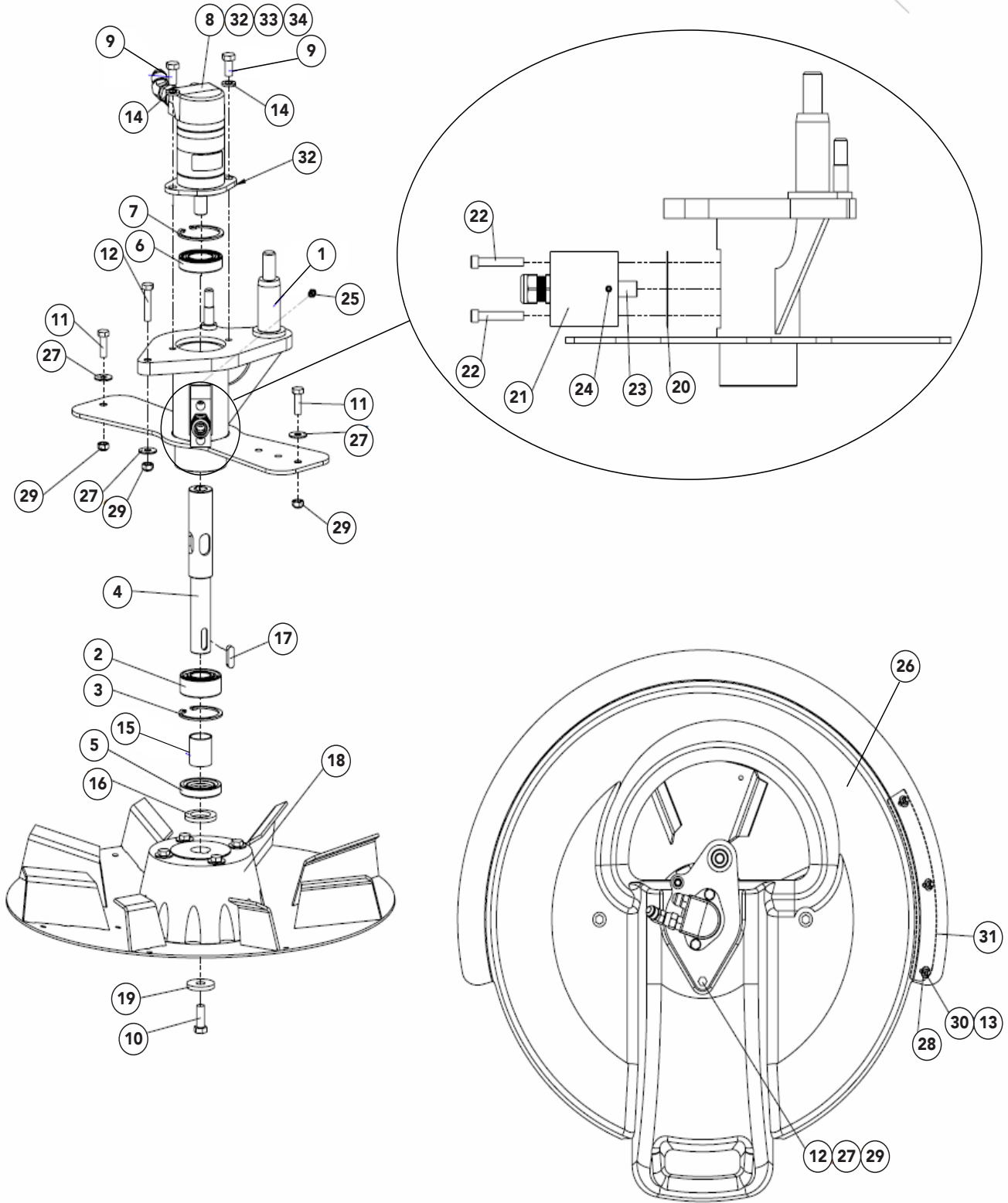

Spinner**Lower Spinner Assembly**

<u>ITEM</u>	<u>PART NO.</u>	<u>DESCRIPTION</u>	<u>QTY</u>
1	307883	OHLA - Wldmt 304	1
2	307876	Bearing - Ball Double Row 25mm	1
3	307877	Ring - Snap Internal 52mm	1
4	307873	Shaft - OHLA 304	1
5	307881	Seal - Shaft 28mm	1
6	307878	Bearing - Ball 30mm	1
7	307879	Ring - Snap Internal 55mm	1
8	307967	Motor - Assy Hyd includes items 32-34	1
9	36293	Cap Screw - .375-16NC x .75 SS	2
10	312456	Cap Screw - .375-16NC x 1 SS w/ Nylon Strip	1
11	34580	Cap Screw - .313-18NC x 1 SS	2
12	308056	Cap Screw - .313-18NC x 1.5 SS	1
13	36394	Cap Screw - .25-20NC x .875 SS	3
14	36420	Washer - Lock .375 SS	2
15	307882	Spacer - Spinner 304	1
16	307880	Spacer - 1.000 ID x 7 GA 304	1
17	307747	Key - Rect .313 x .25 x 1 SS	1
18	307773	Spinner - Disc Assy	1
19	307746	Spacer - .438 ID x 7GA 304	1
20	307885	Gasket - Mount Sensor	1
21	307884	Block - Sensor	1
22	308047	Cap Screw - Socket HD .25-20NC x 1.5 SS	2
23	308177	Sensor - 12mm	1
24	308048	Screw - Set Nylon Tip #10-24NC x .25 SS	1
25	6072	Zerk - Grease	1
26	307919	Shroud - Spinner	1
27	36424	Washer - Flat .313 SS	3
28	36423	Washer - Flat .25 SS	6
29	42221	Nut - Lock .313-18NC SS	3
30	42034	Nut - Lock .25-20NC SS	3



Spinner**Lower Spinner Assembly**

<u>ITEM</u>	<u>PART NO.</u>	<u>DESCRIPTION</u>	<u>QTY</u>
31	307961	Strip - Wear 304	1
32	307783	Motor - Hyd 1.21 CID	1
33	34809	Fitting - 8-6 070120	2
34	34805	Fitting - 8-8 070321	1



This page is intentionally left blank.

Spinner

Chute Assembly

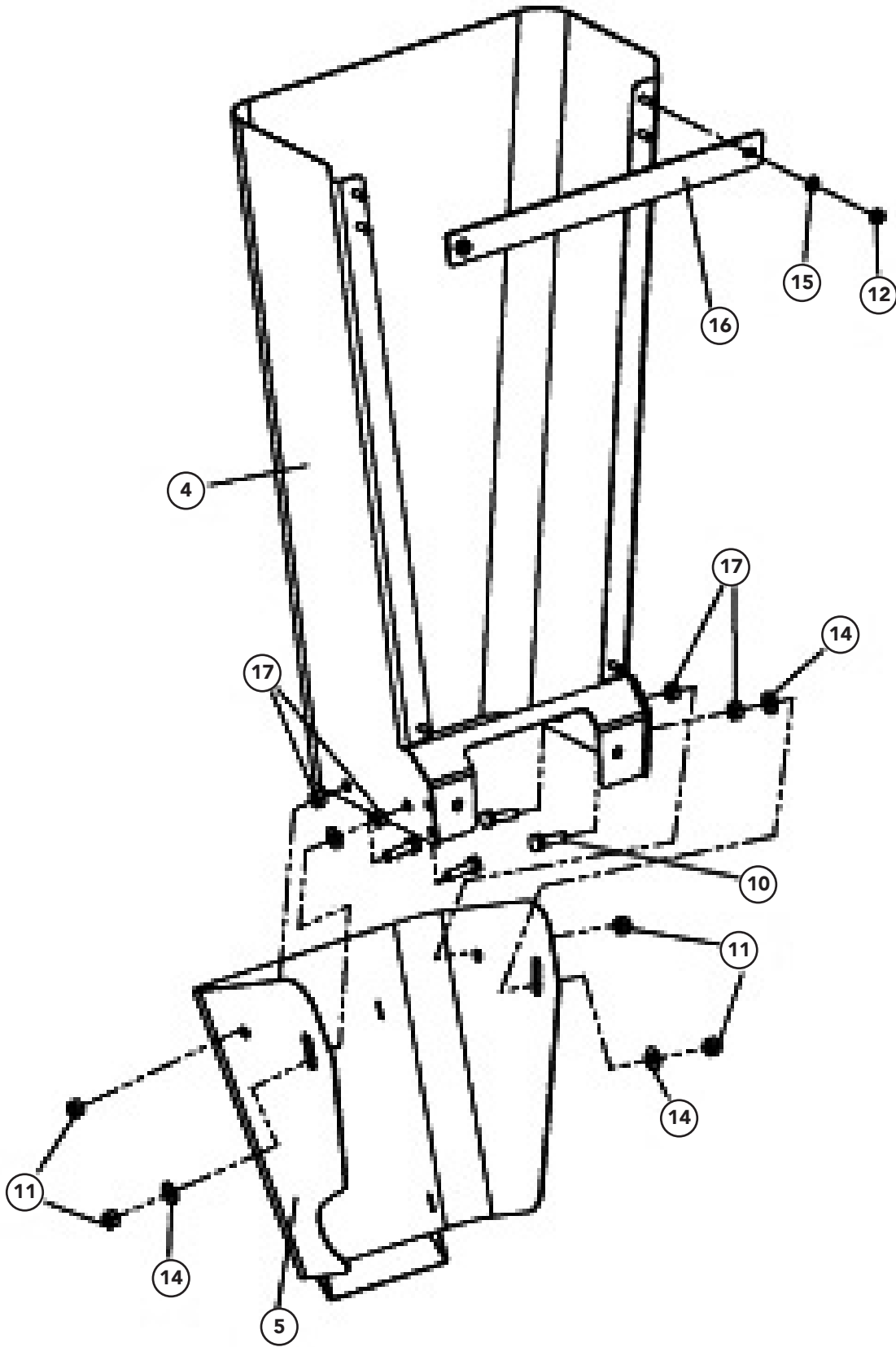

Spinner

Chute Assembly

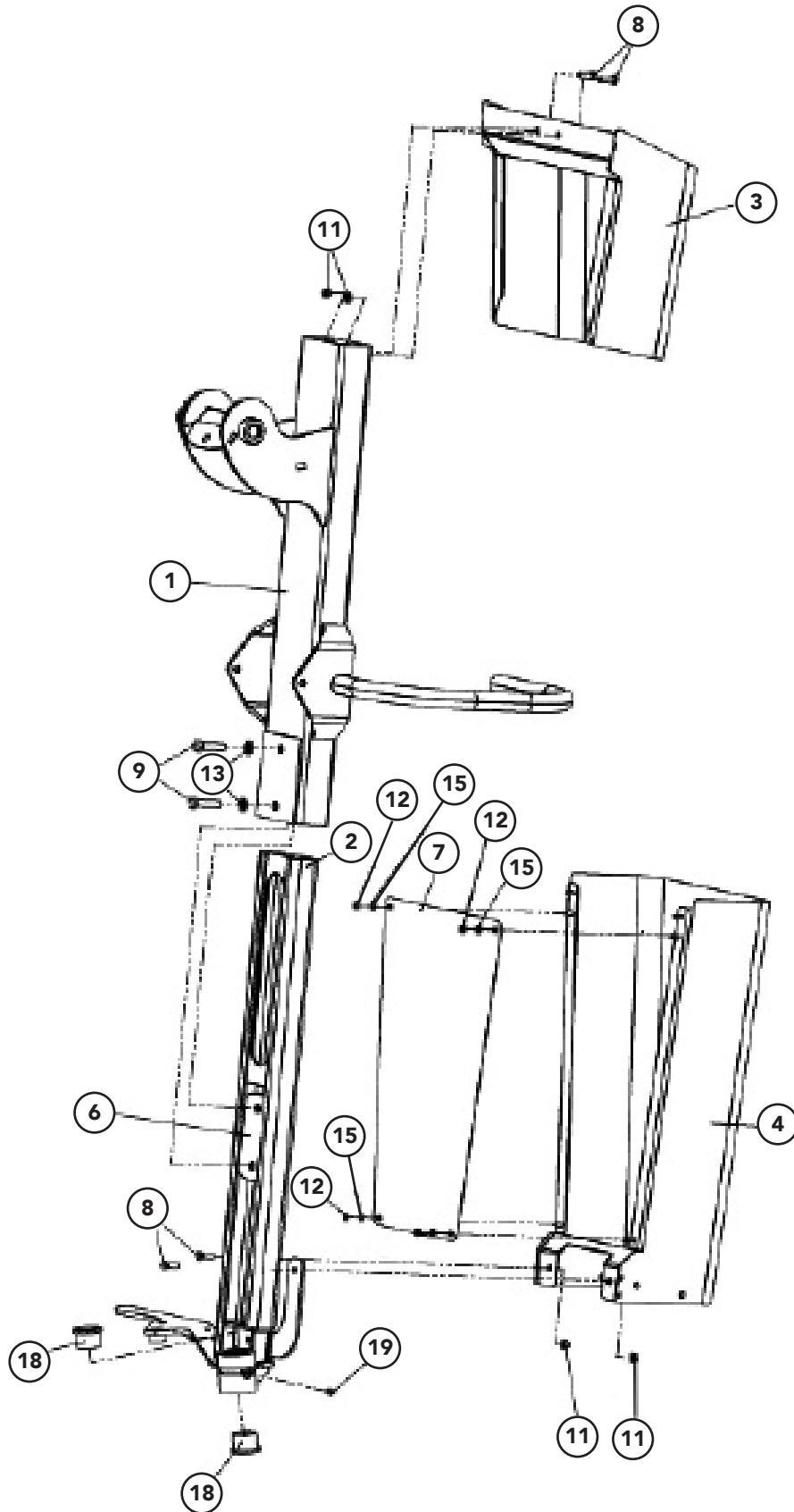

Spinner

Chute Assembly

<u>ITEM</u>	<u>PART NO.</u>	<u>DESCRIPTION</u>	<u>QTY</u>
1	316780	Support - Wldmt Chute Upper	1
2	316781	Chute - Wldmt Lower Support	1
3	316789	Chute - Wldmt Upper 304	1
4	316793	Chute - Wldmt Lower 304	1
5	307851	Chute - Wldmt Lower Deflector	1
6	307853	Chute - Wldmt Lock Plate 304	1
7	307856	Cover - Lower Chute 304	1
8	36393	Capscrew - .25-20NC X .75 SS	4
9	34858	Capscrew - .375-16NC X 1.5 SS	2
10	36394	Capscrew - .25-20NC X .875 SS	4
11	42034	Nut - Lock .25-20NC SS	8
12	307974	Nut - Locking #10-32Nf SS	6
13	36420	Washer - Lock .375 SS	2
14	36423	Washer - Flat .25 SS	4
15	171052	Washer - Flat #10 SS	6
16	316808	Bracket - Wldmt Lower Chute	1
17	36412	Nut - Hex .25-20NC SS	4
18	307887	Bearing - Flanged Bronze	2
19	311663	Zerk - Grease .25-28 Straight	1



Spinner

Spinner Disc Assembly

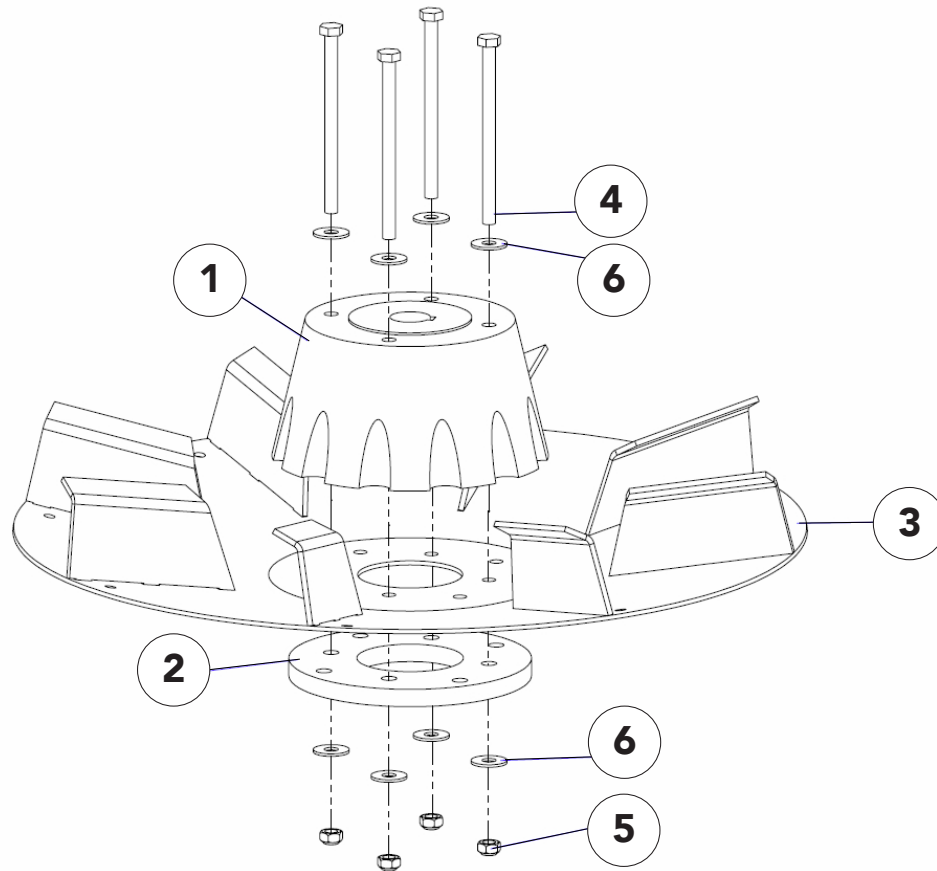

ITEM	PART NO.	DESCRIPTION	QTY
1	307776	Hub	1
2	307777	Hub - Bottom Doubler	1
3	307774	Spinner - Wldmt Disc 304	1
4	307921	Cap Screw - .313-18NC x 4.5 SS	4
5	42221	Nut - Lock .313-18NC SS	4
6	36424	Washer - Flat .313 SS	8

Liquid System

Liquid - Assy Prewet 25 GPM

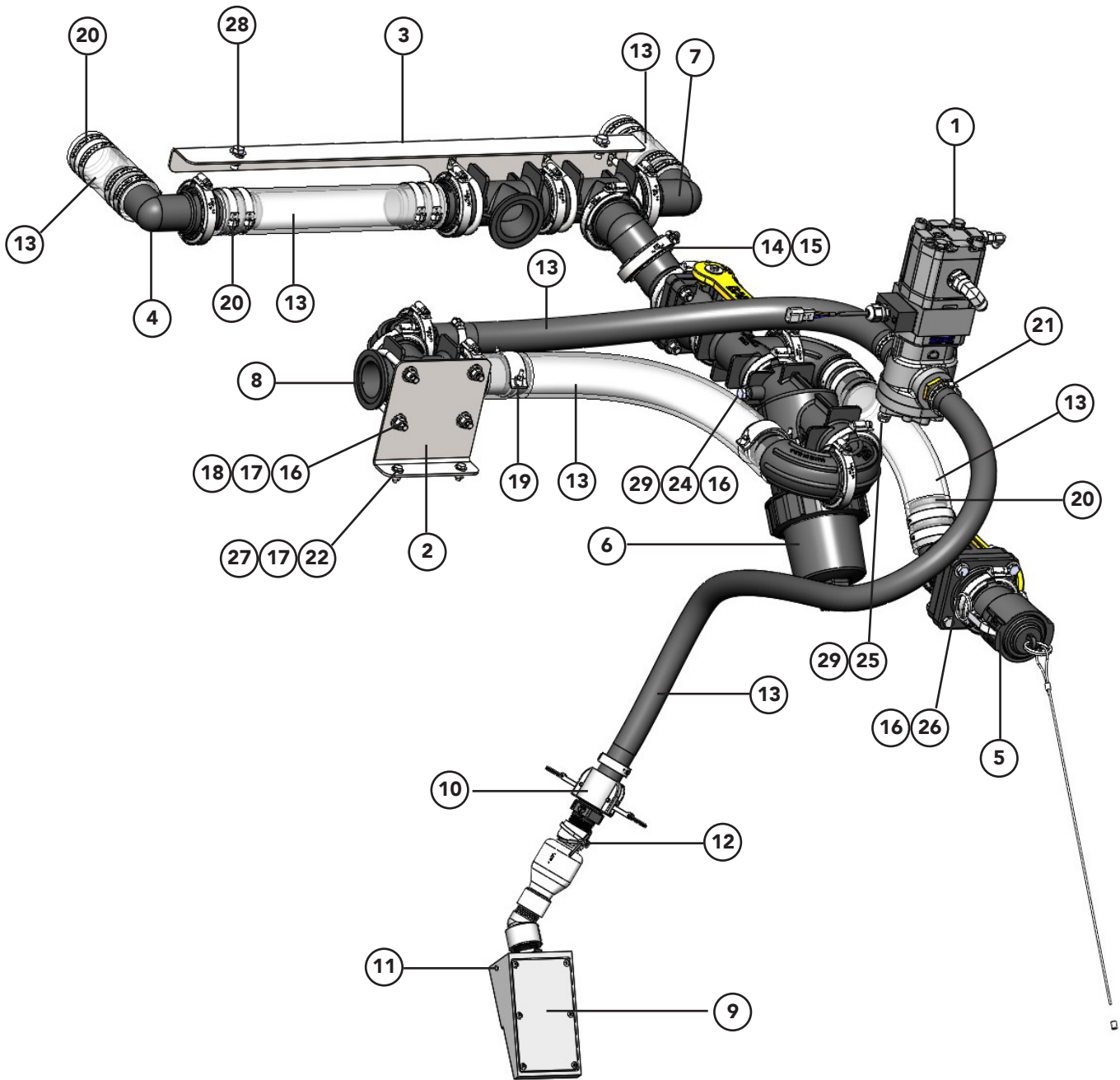

Liquid System**Liquid - Assy Prewet 25 GPM**

<u>ITEM</u>	<u>PART NO.</u>	<u>DESCRIPTION</u>	<u>QTY</u>
1	308043	Pump - Assy Prewet	1
2	316855	Bracket - Angle 304	1
3	316857	Bracket - Angle 304	1
4	316934	Elbow - Assy 2 Hose Barb Poly	1
5	316935	Valve - Assy Poly	1
6	316936	Valve - Assy Strainer Poly	1
7	319221	Tee - Assy Poly	1
8	319220	Tee - Assy Poly	1
9	316922	Diffuser - Assy	1
10	310675	Coupling - 1 Female X 1 Hose	1
11	56315	Screw - Self Drilling #6-20nc	2
12	99674	Strap - Zip Tie 8 Black	2
13	319219	Hose - Group Prewet 25 GPM	1
14	316885	Gasket - 2fp Epdm	1
15	316884	Clamp - Worm 2 300 Series SS	1
16	36425	Washer - Flat .375 SS	18
17	36423	Washer - Flat .25 SS	4
18	316889	U-Bolt - 2 18-8 SS	5
19	308170	Clamp - 2 Spiral Double Bolt	2
20	321848	Clamp- Hose T-Bolt SS	16
21	321799	Clamp - Hose Sae 24 SS	4
22	36393	Capscrew - .25-20nc X .75 SS	2
23	*6398	Bearing - Cartridge 1.5	2
24	36293	Capscrew - .375-16nc X .75 SS	2
25	308040	Capscrew - M8 X 20 SS	2
26	36400	Capscrew - .375-16nc X 2.5 SS	2
27	42034	Nut - Lock .25-20nc SS	2
28	72054	Nut - Lock .375-16nc SS	2
29	36420	Washer - Lock .375 SS	4
30	*308240	Loctite - Plastic Pipe Sealant	0
31	*308241	Sealant - Rtv 732	0

* Not Shown



Liquid System

Plug Group

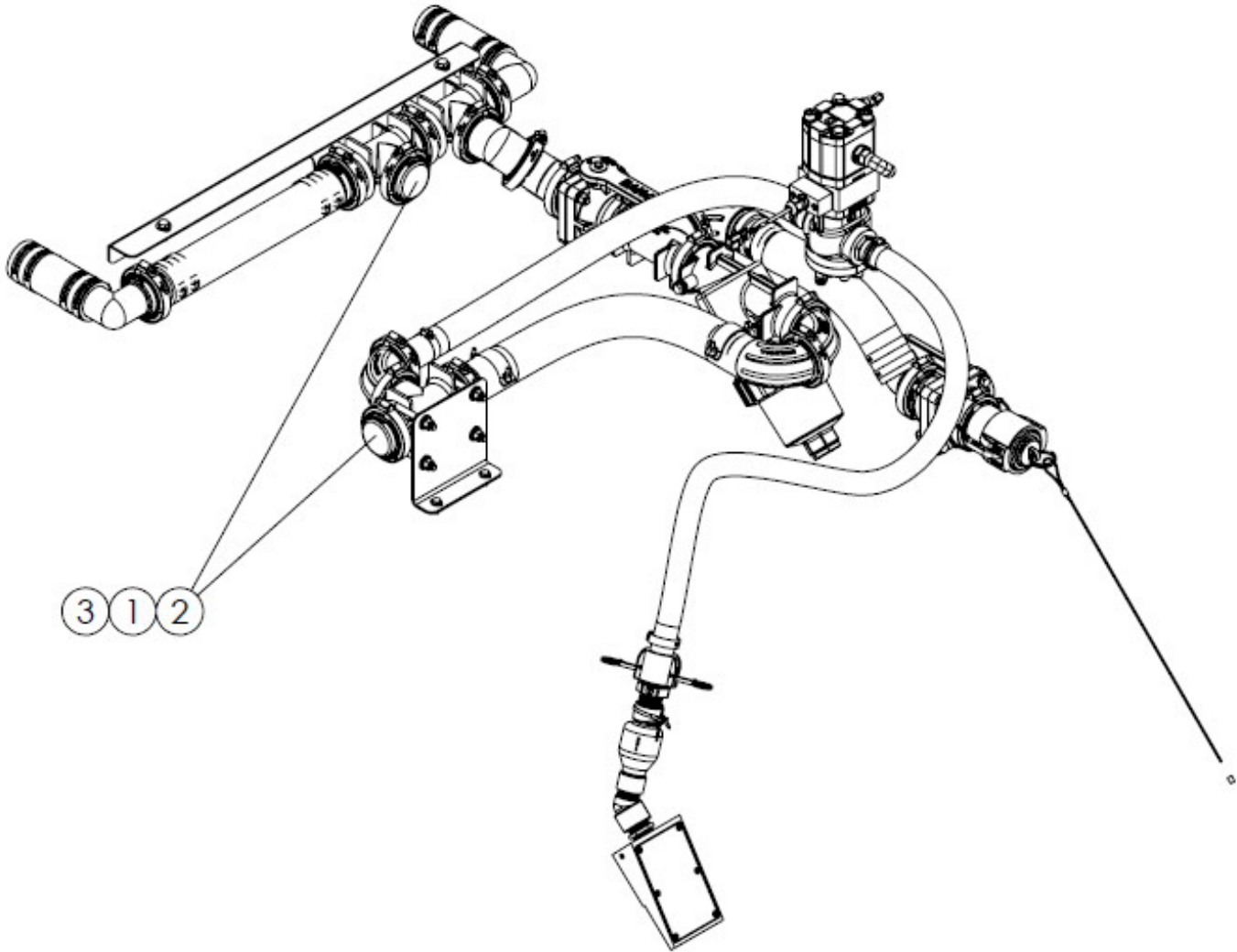

Liquid System

Plug Group

<u>ITEM</u>	<u>PART NO.</u>	<u>DESCRIPTION</u>	<u>QTY</u>
1	316885	Gasket - 2fp Epdm	2
2	319238	Fitting - Plug 2fp Manifold	2
3	316884	Clamp - Worm 2 300 Series SS	2



Liquid System

Liquid - Assy Prewet 50 GPM

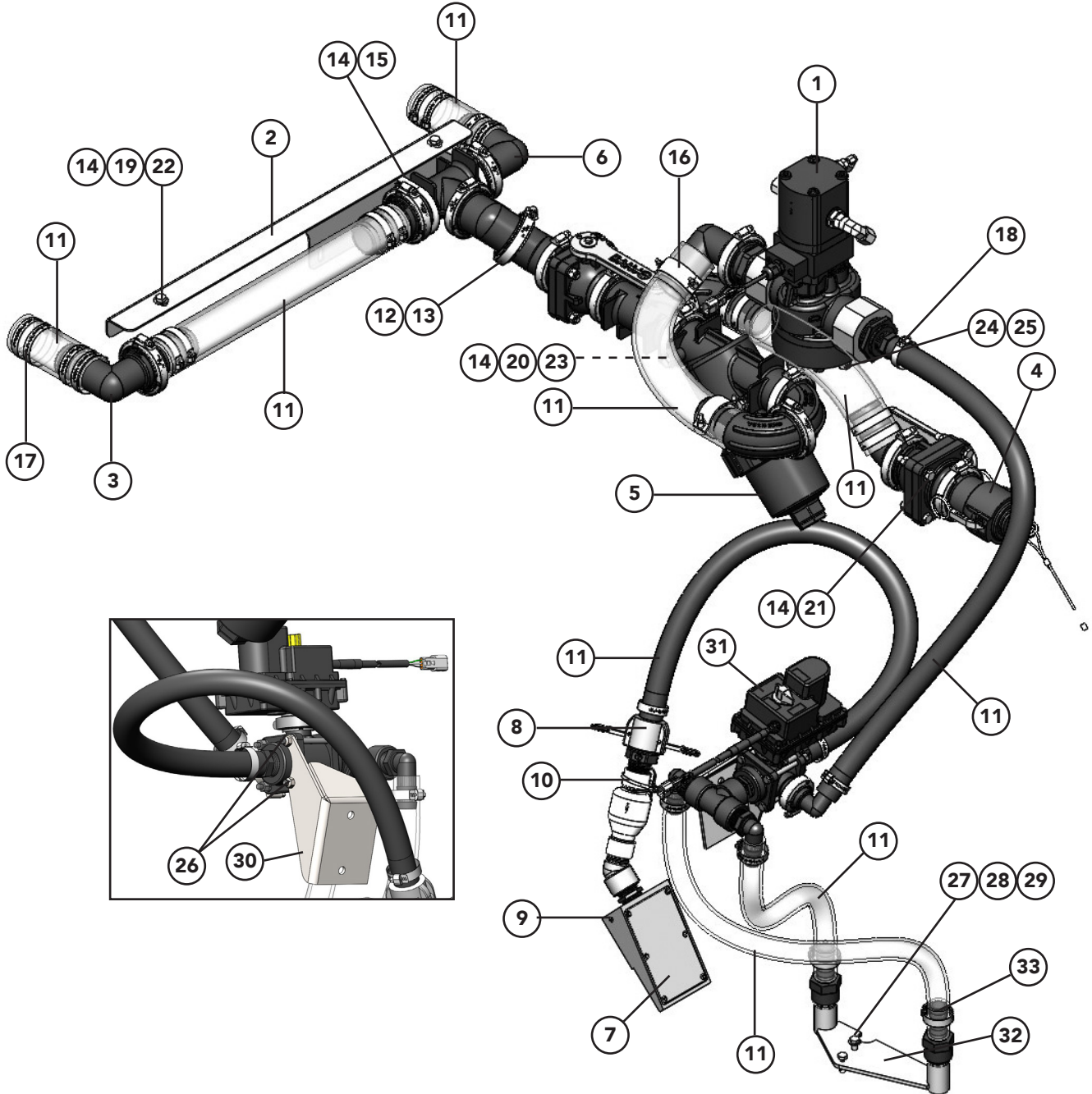

ITEM	PART NO.	DESCRIPTION	QTY
1	319236	Pump - Assy	1
2	316857	Bracket - Angle 304	1
3	316934	Elbow - Assy 2 Hose Barb Poly	1
4	316935	Valve - Assy Poly	1
5	316936	Valve - Assy Strainer Poly	1



Liquid System**Liquid - Assy Prewet 50 GPM**

<u>ITEM</u>	<u>PART NO.</u>	<u>DESCRIPTION</u>	<u>QTY</u>
6	319239	Tee - Assy Poly	1
7	316922	Diffuser - Assy	1
8	310675	Coupling - 1 Female X 1 Hose	1
9	56315	Screw - Self Drilling #6-20nc	2
10	99674	Strap - Zip Tie 8 Black	2
11	319237	Hose - Group	1
12	316885	Gasket - 2fp Epdm	1
13	316884	Clamp - Worm 2 300 Series SS	1
14	36425	Washer - Flat .375 SS	12
15	316889	U-Bolt - 2 18-8 SS	2
16	308170	Clamp - 2 Spiral Double Bolt	2
17	321848	Clamp- Hose T-Bolt SS	16
18	321799	Clamp - Hose Sae 24 SS	8
19	36398	Capscrew - .375-16nc X 1 SS	2
20	36293	Capscrew - .375-16nc X .75 SS	2
21	36400	Capscrew - .375-16nc X 2.5 SS	2
22	72054	Nut - Lock .375-16nc SS	2
23	36420	Washer - Lock .375 SS	2
24	96921	Capscrew - M10 X 20 SS	4
25	36421	Washer - Lock .438 SS	4
26	42221	Nut - Lock .313-18nc SS	4
27	36397	Capscrew - .313-18nc X 1.25 SS	1
28	36424	Washer - Flat .313 SS	1
29	34580	Capscrew - .313-18nc X 1 SS	1
30	309936	Bracket - Valve 304	1
31	309938	Valve - Assy 3-Way Motorized	1
32	309932	Bracket - Wldmt 304	1
33	309926	Fitting - Hose Barb 1.00 Hose	2
34	*308240	Loctite - Plastic Pipe Sealant	0
35	*308241	Sealant - Rtv 732	0

* Not Shown



Liquid System

3-Way Motorized Valve Assembly

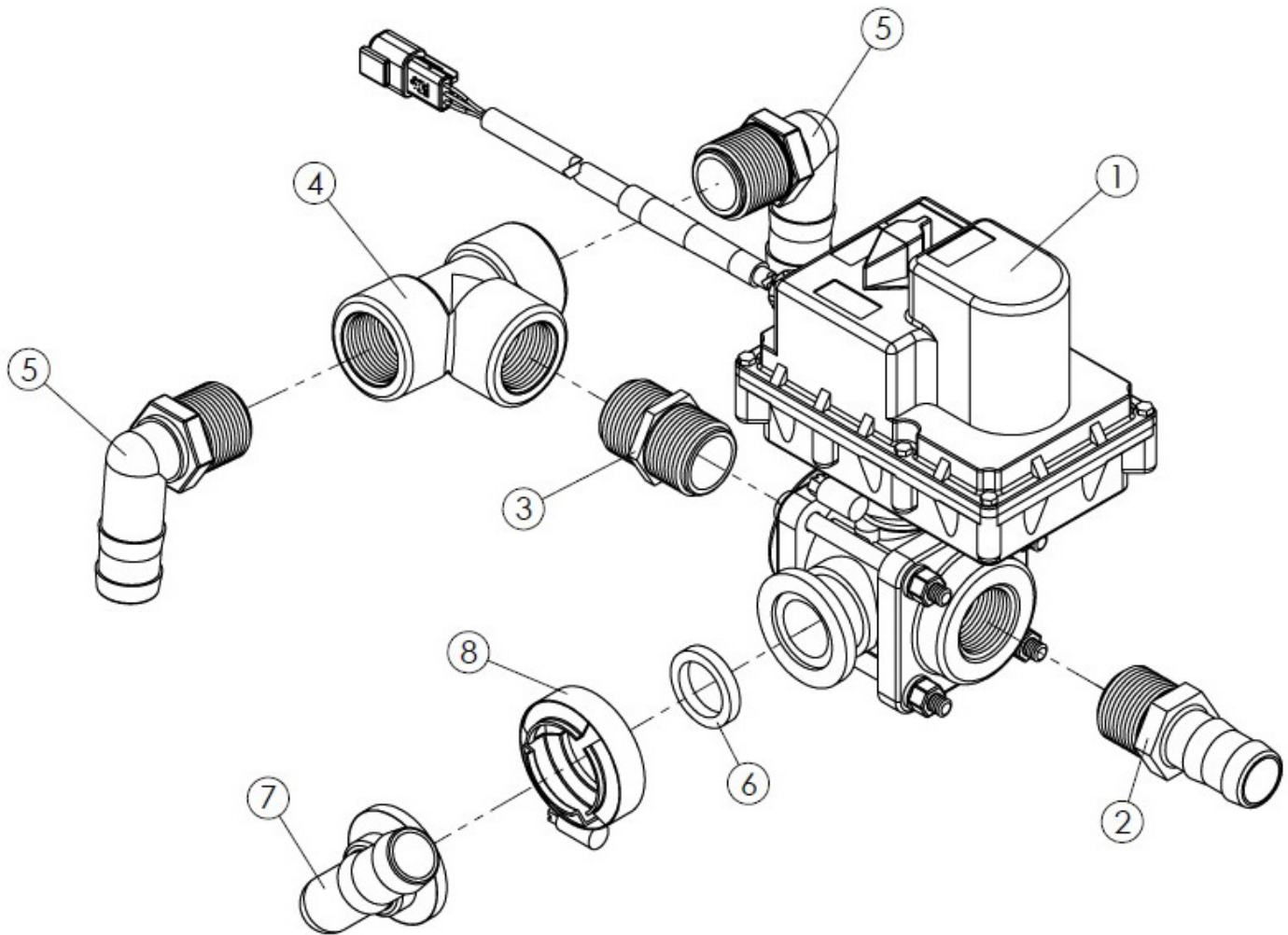

ITEM	PART NO.	DESCRIPTION	QTY
1	309918	VALVE - 1 ELEC 3-WAY W/	1
2	307895	FITTING - HOSE BARB 1 HOSE X	1
3	309923	FITTING - NIPPLE SHORT 1.00NPT	1
4	309924	FITTING - TEE 1.00 NPT POLY	1
5	309925	FITTING - HOSE BARB 90° 1.00	2
6	309929	GASKET - 1.00 FLANGE EPDM	1
7	309927	FITTING - HOSE BARB 90° 1.00	1
8	309928	CLAMP - FLANGE	1
9	*308240	LOCTITE - PLASTIC PIPE SEALANT	0

* Not Shown

Liquid System

Hose Group 25 GPM

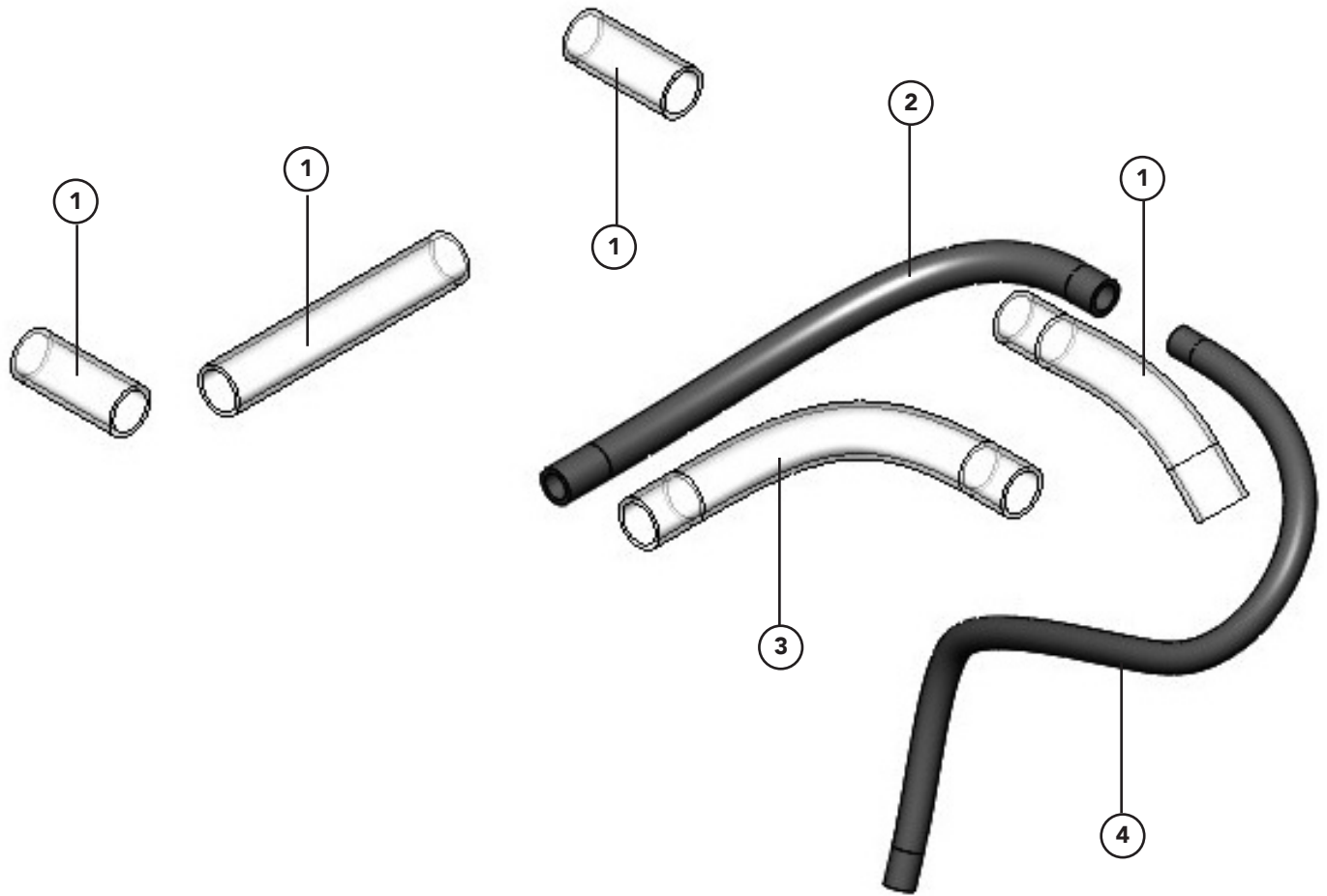

ITEM	PART NO.	DESCRIPTION	QTY
1	307905	Hose - 2 Vaccum/Transfer Pvc	3.3'
2	307906	Hose - 1.25 Vac/Transfer Pvc	2.5'
3	308169	Hose - 2 Pvc	2'
4	307909	Hose - 1 Epdm Suction	4.5'

Liquid System

Hose Group 50 GPM

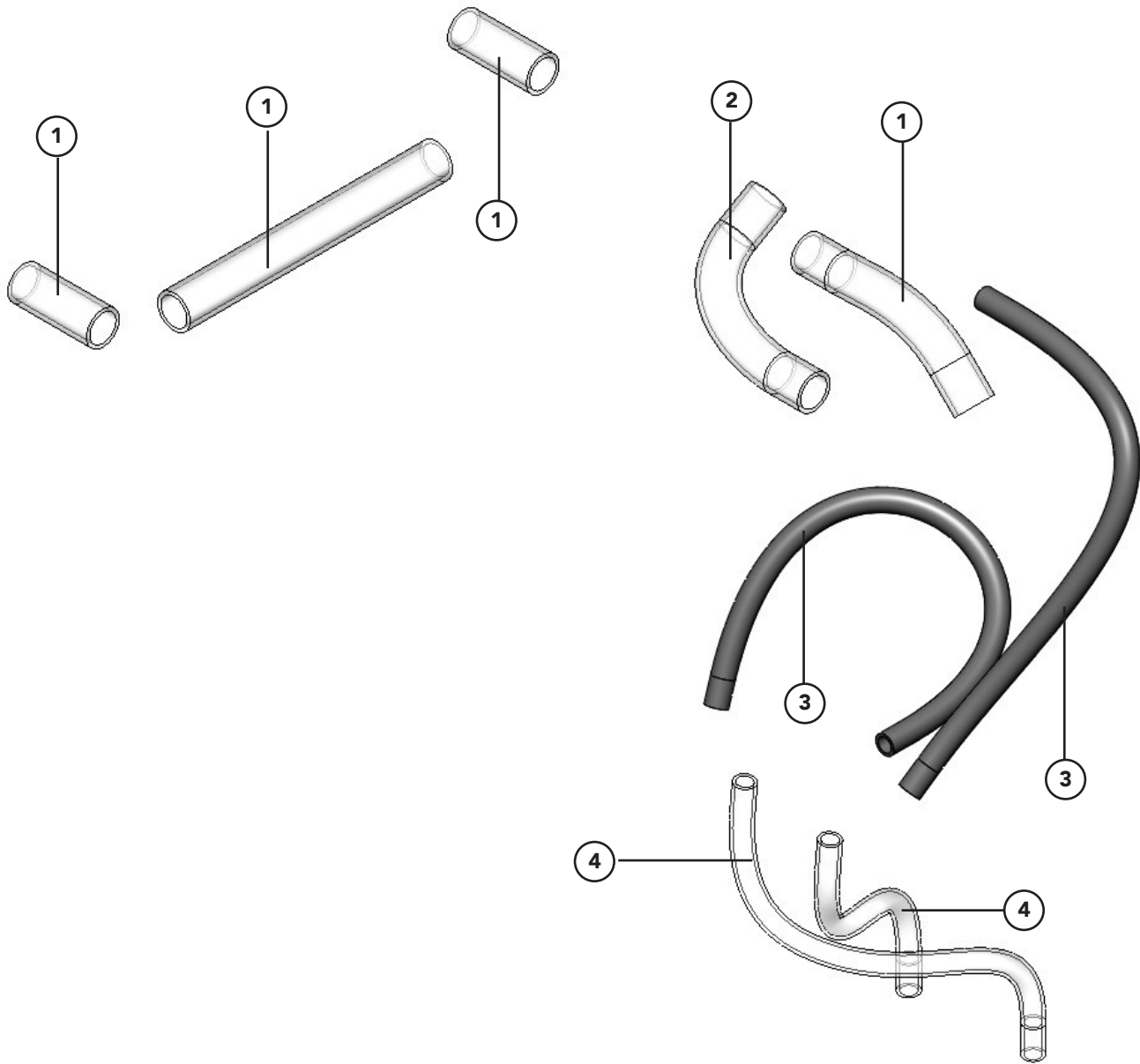

ITEM	PART NO.	DESCRIPTION	QTY
1	307905	Hose - 2 Vaccum/Transfer Pvc	3.8'
2	308169	Hose - 2 Pvc	1.3'
3	307909	Hose - 1 Epdm Suction	4.5'
4	307907	Hose - 1 Vaccum/Transfer Pvc	6.0'

Liquid System

Pump Assembly 25 GPM

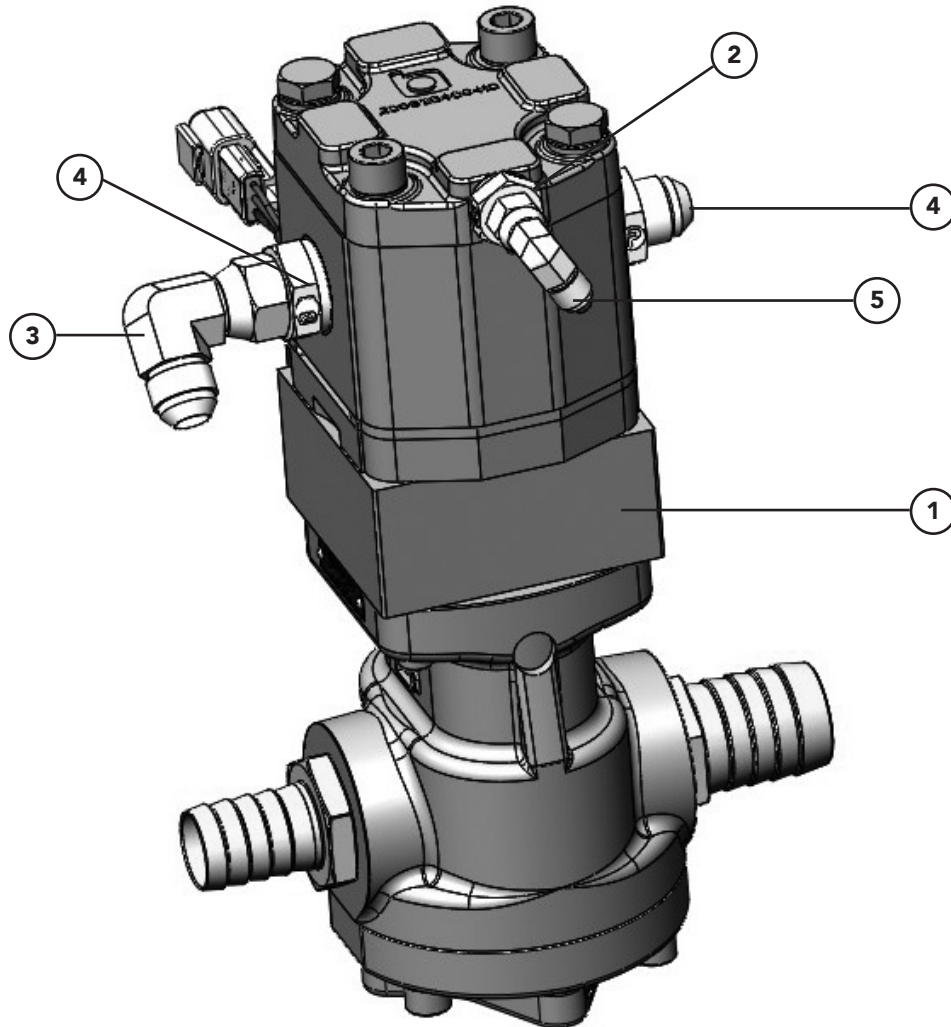

ITEM	PART NO.	DESCRIPTION	QTY
1	308181	Pump - Assy Prewet W/Dt04-3p	1
2	308045	Fitting - .25 Bsp Male X .25	1
3	308044	Fitting - .5 Bsp Male X .5jic	2
4	34803	Fitting - 8-8- 070221	1
5	34868	Fitting - 4-4 070221	1



Liquid System

Pump Assembly 50 GPM

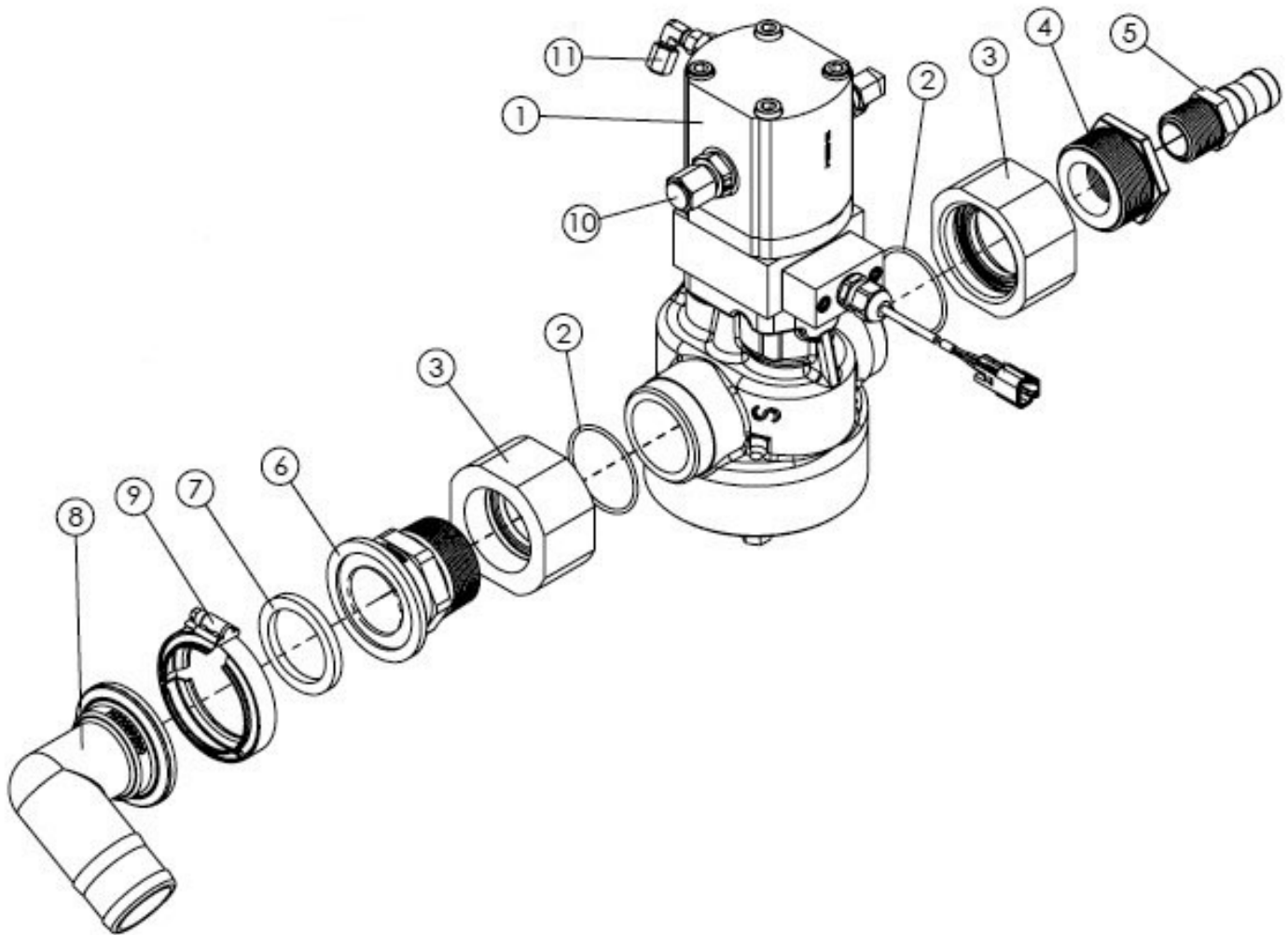

Liquid System**Pump Assembly 50 GPM**

<u>ITEM</u>	<u>PART NO.</u>	<u>DESCRIPTION</u>	<u>QTY</u>
1	309914	Pump - Assy Hi Liquid	1
2	309916	O-Ring - 139	2
3	309915	Adapter - 2.25 Bsppf X 2 Nptf	2
4	309922	Fitting - Bushing 2.00mnpt X 1.00 Fnpt Poly	1
5	307895	Fitting - Hose Barb 1 Hose X 1 Mnpt Poly	1
6	317161	Fitting - Adapter 2fp Manifold	1
7	316885	Gasket - 2fp Epdm	1
8	317117	Fitting - Hose Barb 90° 2fp	1
9	316884	Clamp - Worm 2 300 Series SS	1
10	311754	Fitting - 8 070112	2
11	34855	Cap - 4 070112 Cap - Jic	1



Liquid System

Elbow Assembly

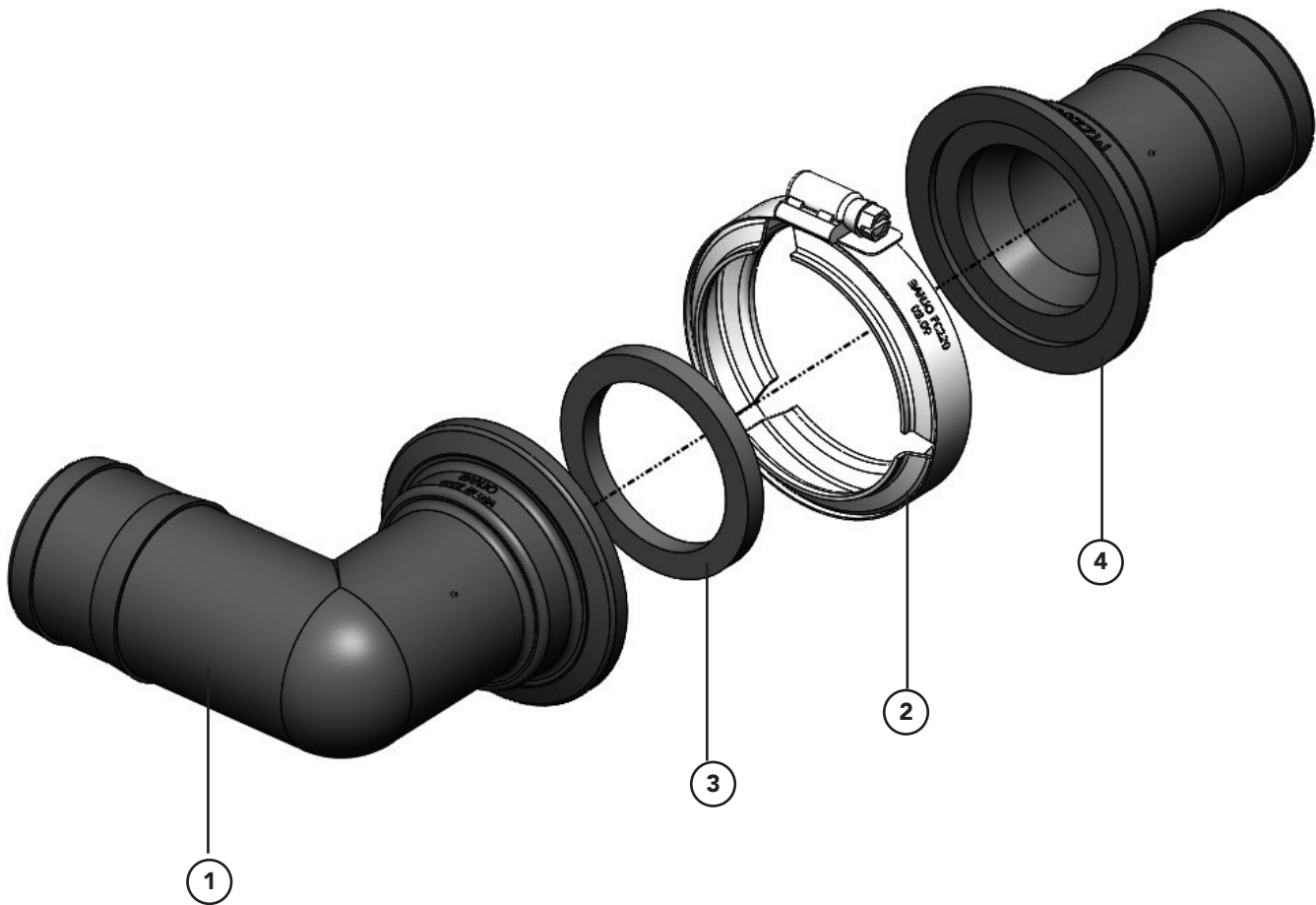

ITEM	PART NO.	DESCRIPTION	QTY
1	317117	Fitting - Hose Barb 90° 2fp	1
2	316884	Clamp - Worm 2 300 Series SS	1
3	316885	Gasket - 2fp Epdm	1
4	316876	Fitting - Hose Barb 2fp	1

Liquid System

Strainer Valve Assembly

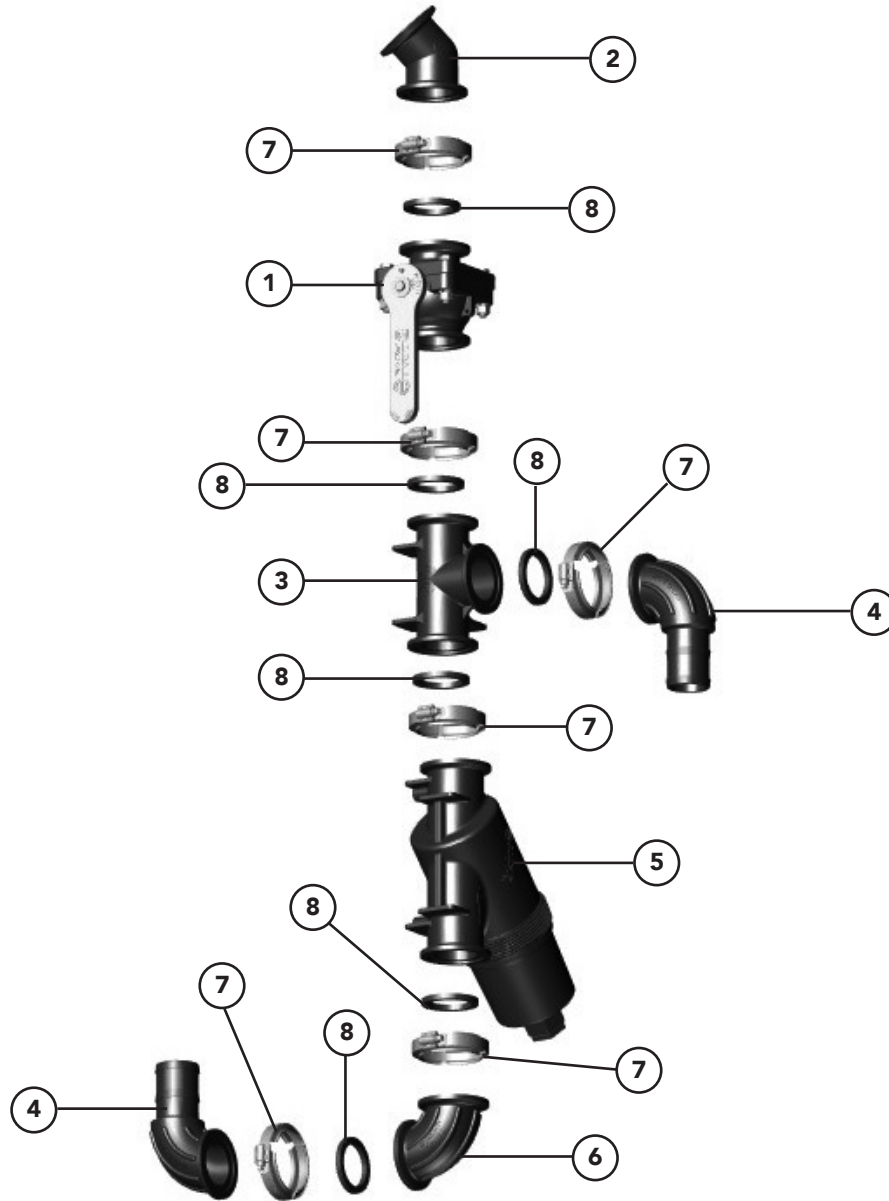

ITEM	PART NO.	DESCRIPTION	QTY
1	316880	Valve - Stubby 2fp Manifold	1
2	316879	Fitting - Coupling 45° 2fp	1
3	316875	Fitting - Tee 2fp Manifold	1
4	316878	Fitting - Hose Barb Sweep	2
5	316881	Y Strainer - 2fp Manifold	1
6	316874	Fitting - Sweep 90° 2fp	1
7	316884	Clamp - Worm 2 300 Series SS	6
8	316885	Gasket - 2fp Epdm	6



Liquid System

Fill/Pump Valve Assembly

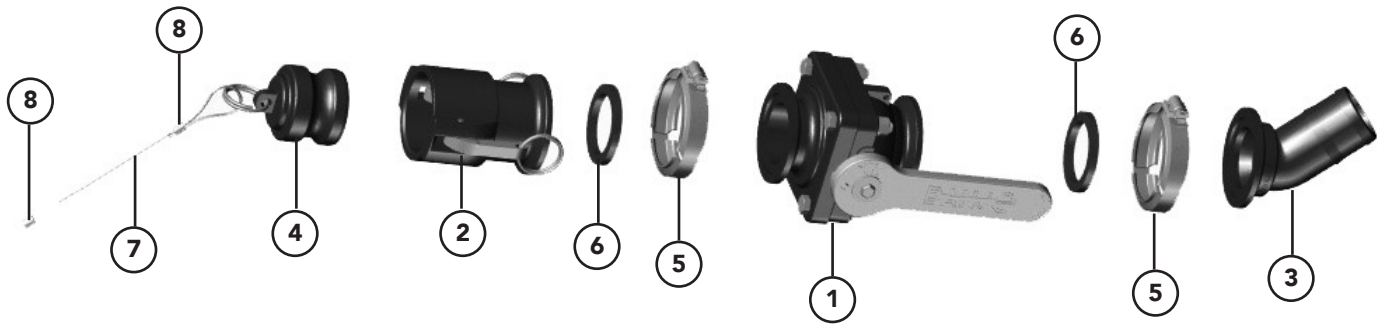

ITEM	PART NO.	DESCRIPTION	QTY
1	316880	Valve - Stubby 2fp Manifold	1
2	316899	Fitting - Adapter 2fp Manifold	1
3	316882	Fitting - Hose Barb 45° 2fp	1
4	316900	Plug - 2 Qdc	1
5	316884	Clamp - Worm 2 300 Series SS	2
6	316885	Gasket - 2fp Epdm	2
7	308084	Cable - .094 X 24 Coated	1
8	308085	Ferrule - .185 X .374	2

Liquid System

Tee Assembly #1

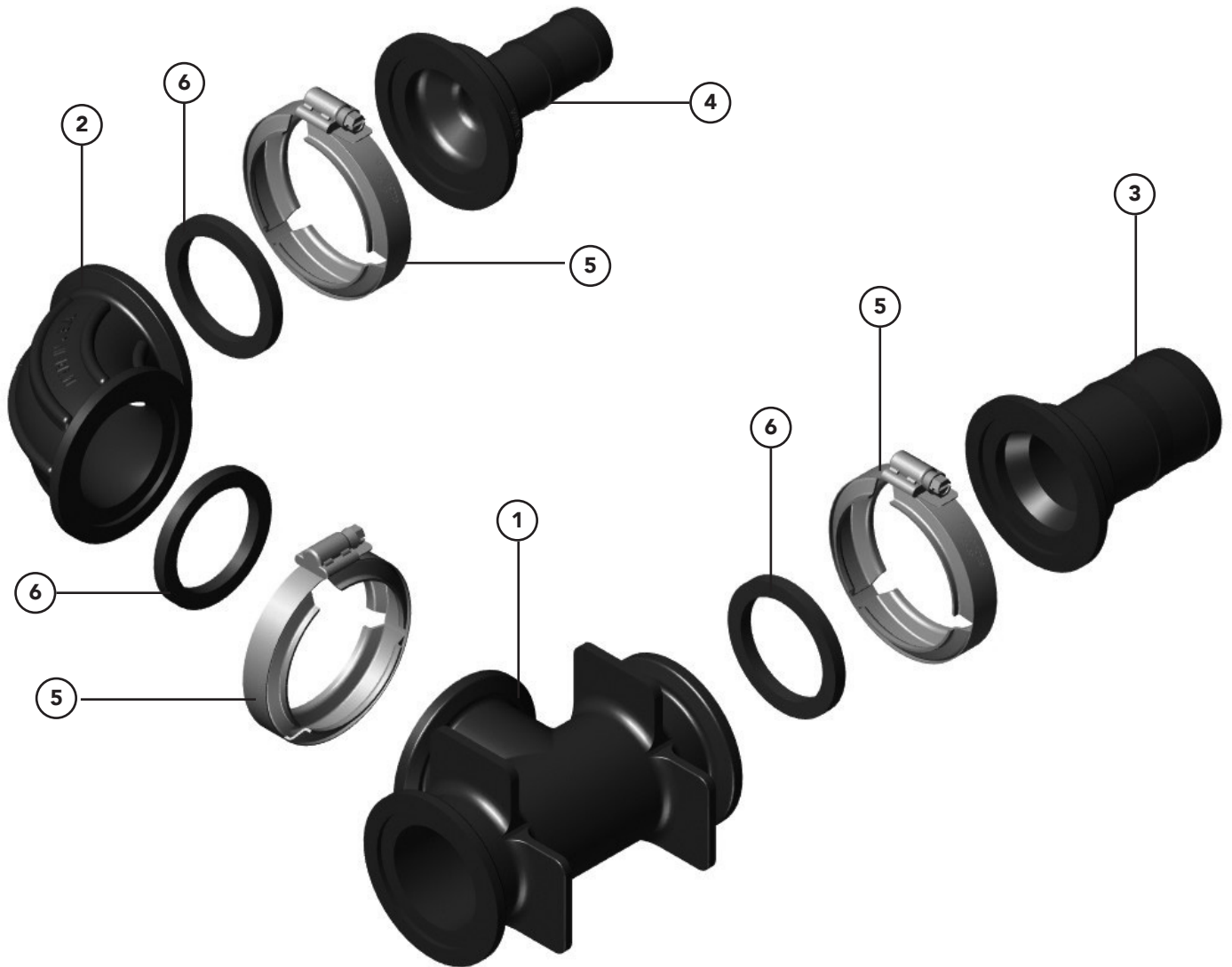

ITEM	PART NO.	DESCRIPTION	QTY
1	316875	Fitting - Tee 2fp Manifold	1
2	316874	Fitting - Sweep 90° 2fp	1
3	316876	Fitting - Hose Barb 2fp	1
4	316877	Fitting - Hose Barb 1.25 X 2fp	1
5	316884	Clamp - Worm 2 300 Series SS	3
6	316885	Gasket - 2fp Epdm	3



Liquid System

Tee Assembly #2

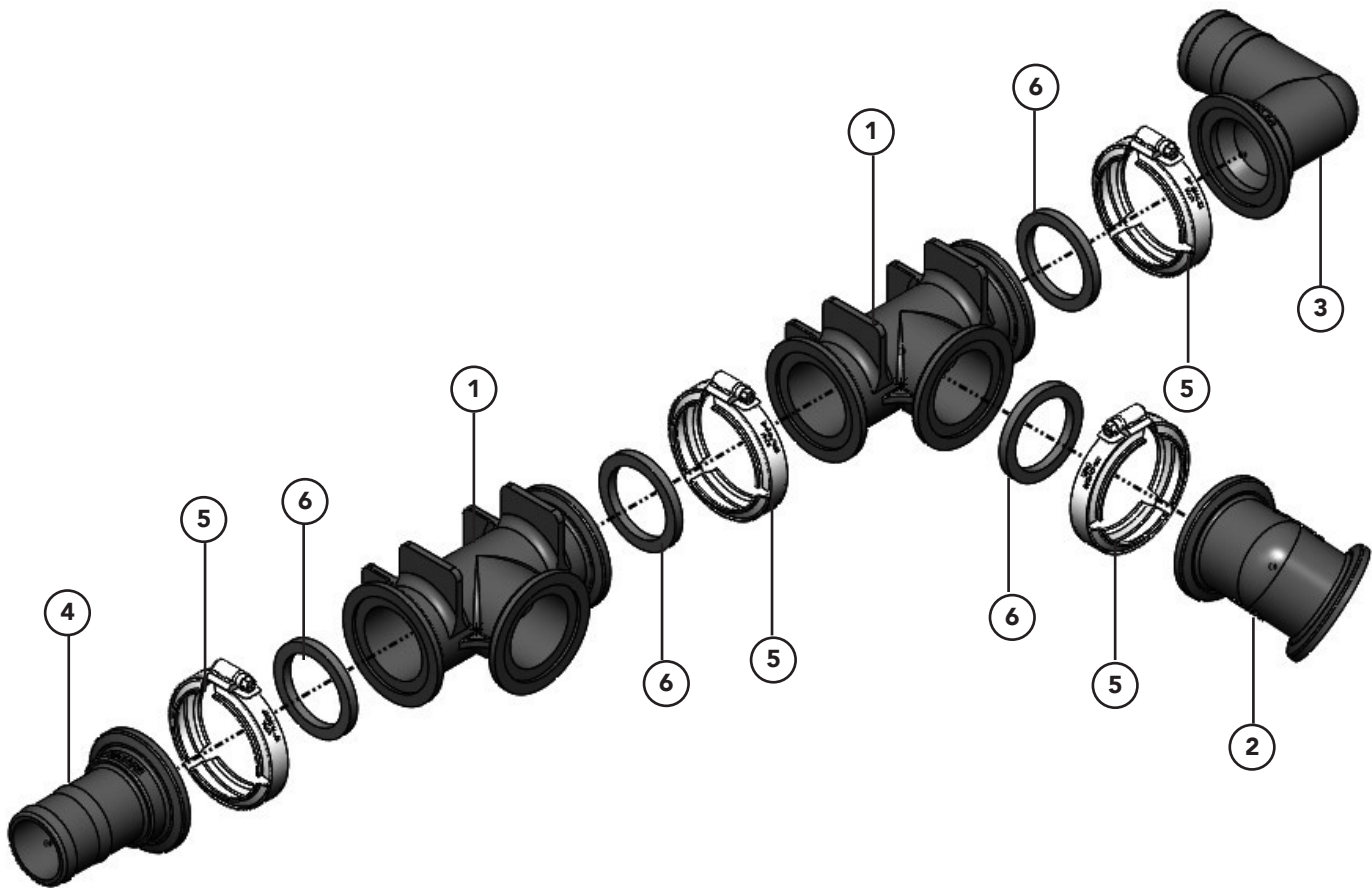

<u>ITEM</u>	<u>PART NO.</u>	<u>DESCRIPTION</u>	<u>QTY</u>
1	316875	Fitting - Tee 2fp Manifold	2
2	316879	Fitting - Coupling 45° 2fp	1
3	317117	Fitting - Hose Barb 90° 2fp	1
4	316876	Fitting - Hose Barb 2fp	1
5	316884	Clamp - Worm 2 300 Series SS	4
6	316885	Gasket - 2fp Epdm	4

Liquid System

Diffuser Assembly

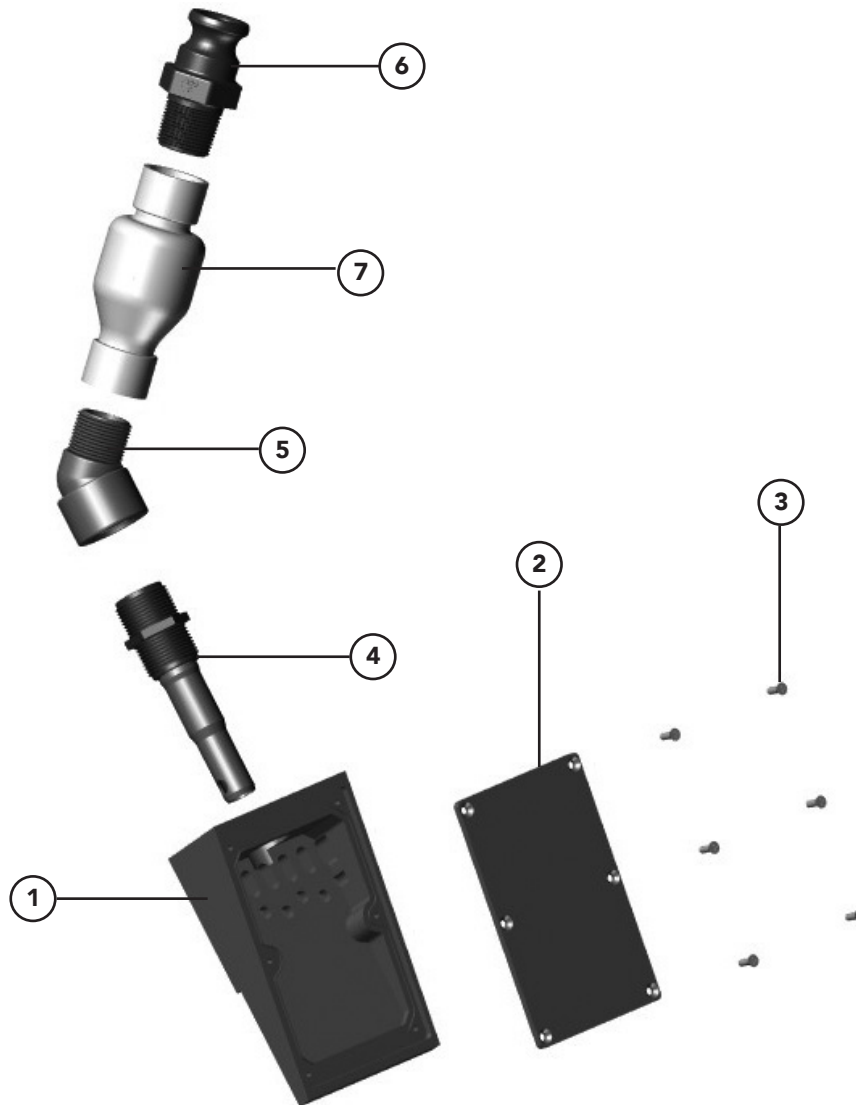

ITEM	PART NO.	DESCRIPTION	QTY
1	307948	DIFFUSER -	1
2	307949	COVER - DIFFUSER	1
3	307947	SCREW - SELF-TAPPING #8-15 X	6
4	310677	INSERT - ASSY DIFFUSER	1
5	310673	ELBOW - 45° 1 NPT POLY	1
6	317172	FITTING - ADAPTER 1 QDC MALE X	1
7	319207	VALVE - CHECK 4.125-17LBS 1FPT	1
8	*308240	LOCTITE - PLASTIC PIPE SEALANT	0
9	*308241	SEALANT - RTV 732	0

* Not Shown



Liquid System

Liquid Tank Group

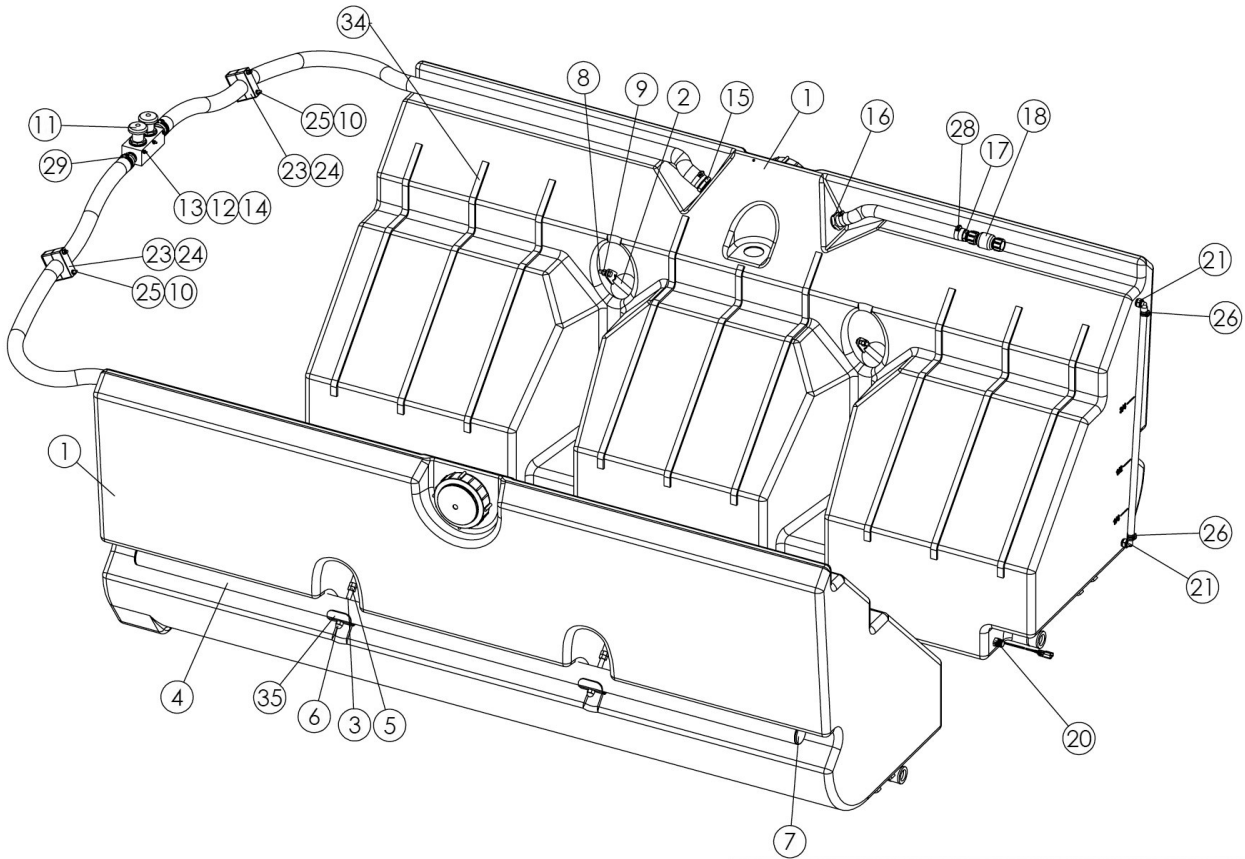
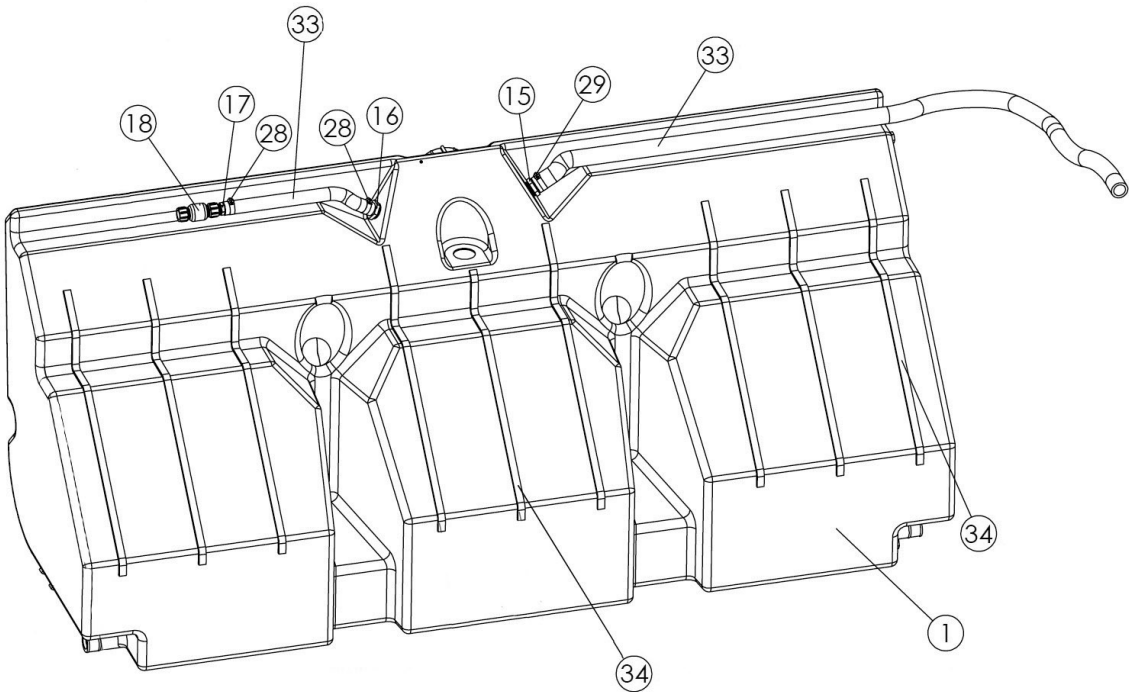

Liquid System

Liquid Tank Group

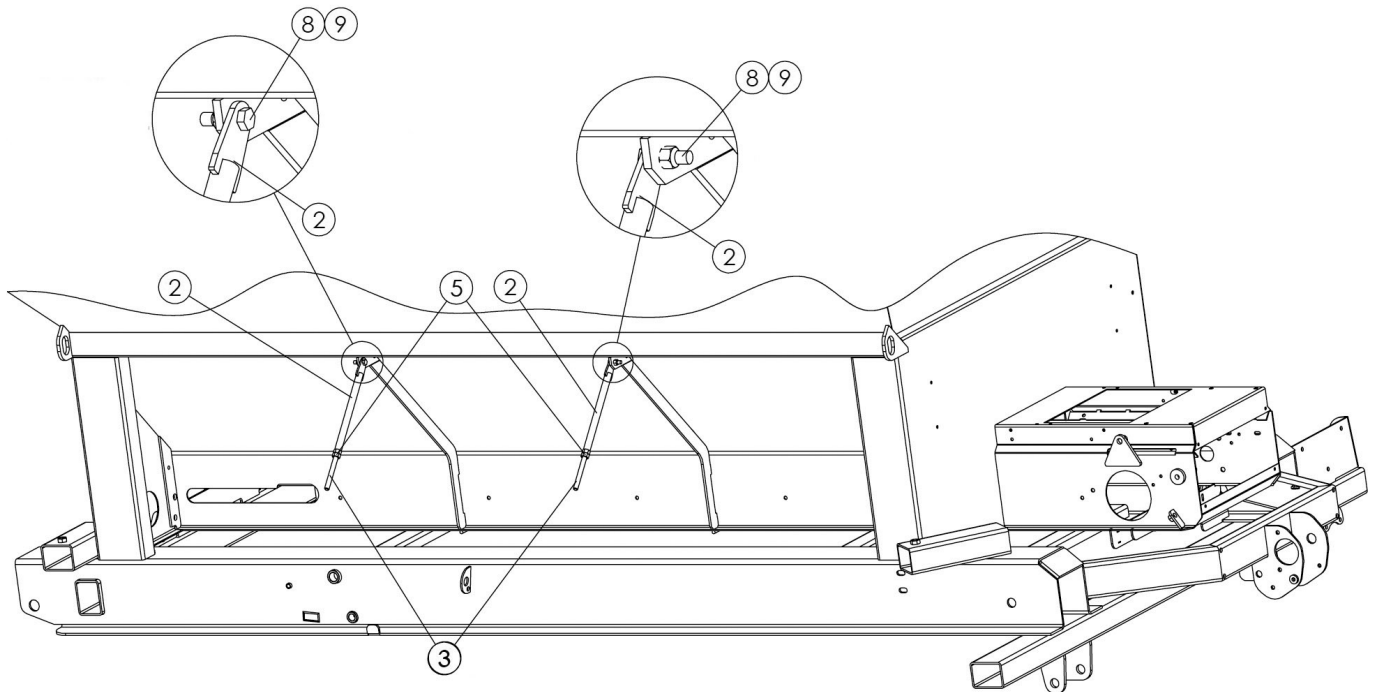
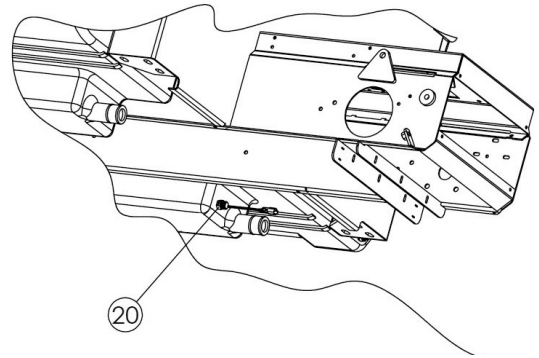
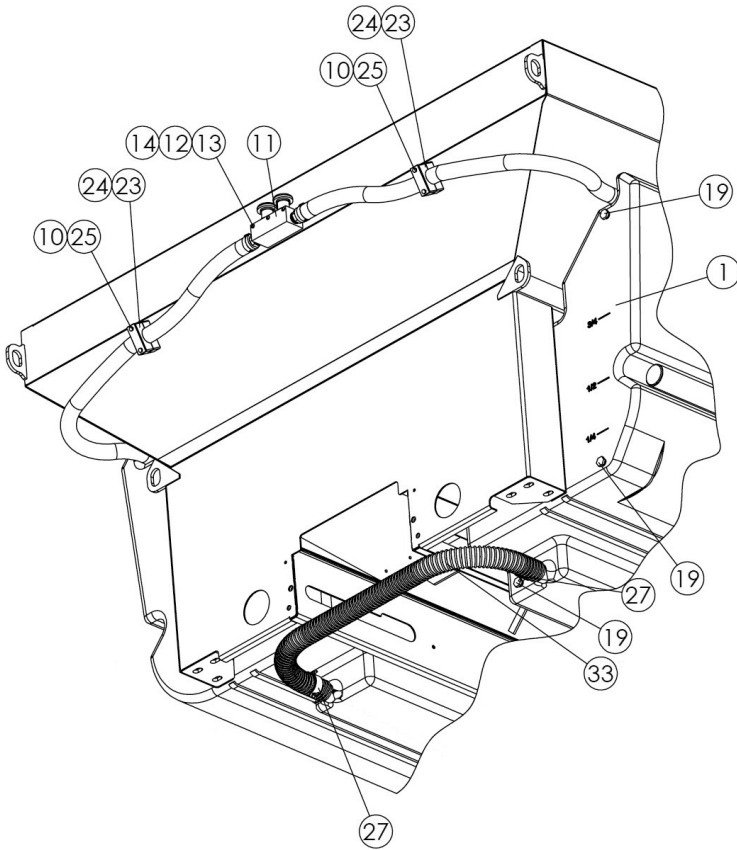

Liquid System

Liquid Tank Group

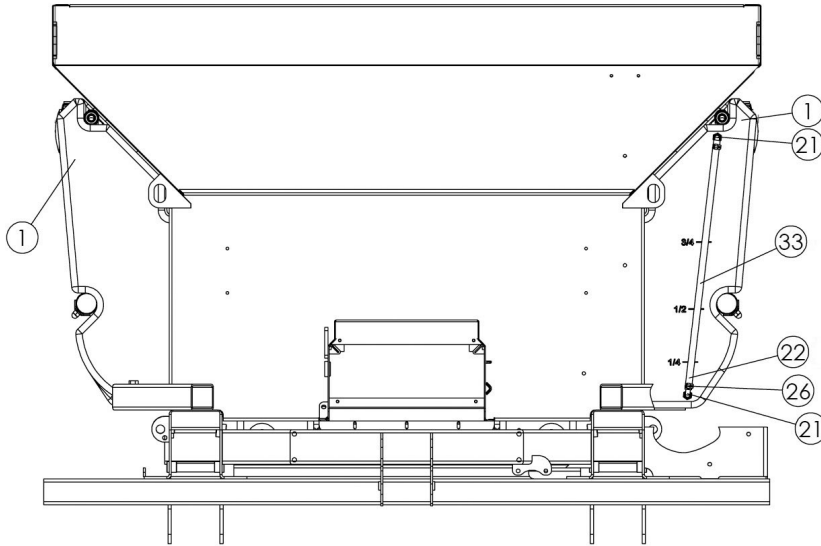
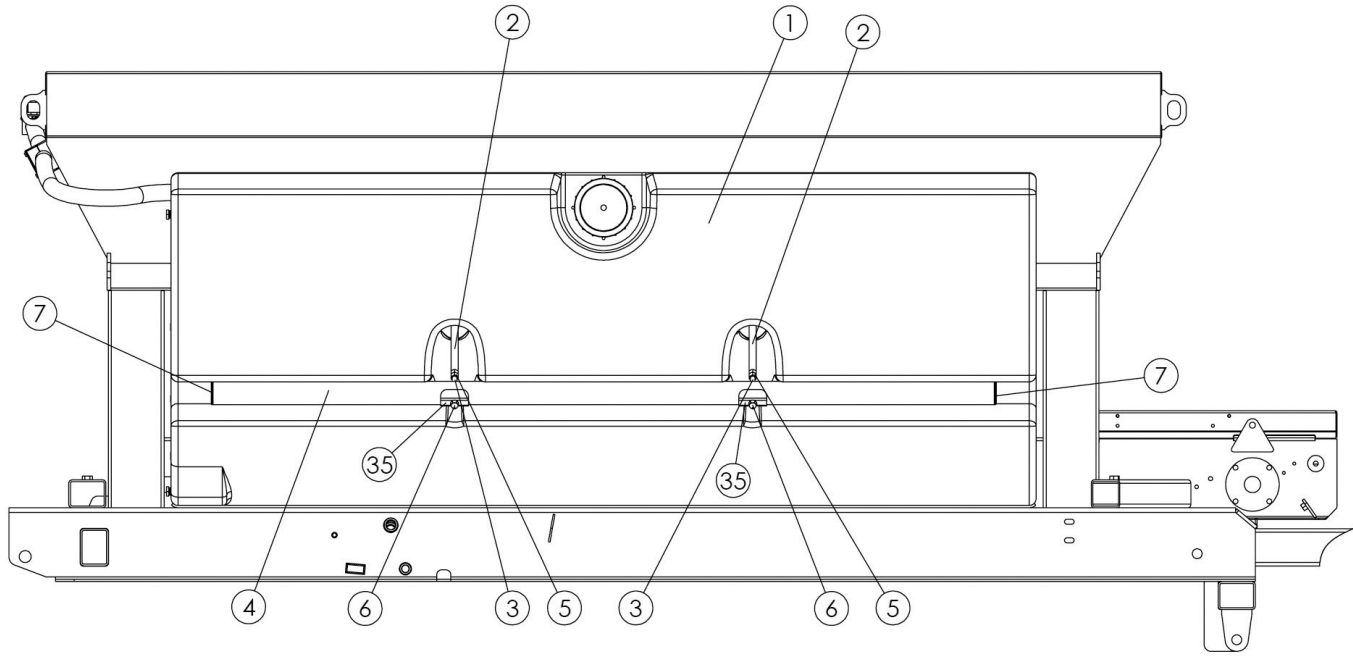

Liquid System

Liquid Tank Group

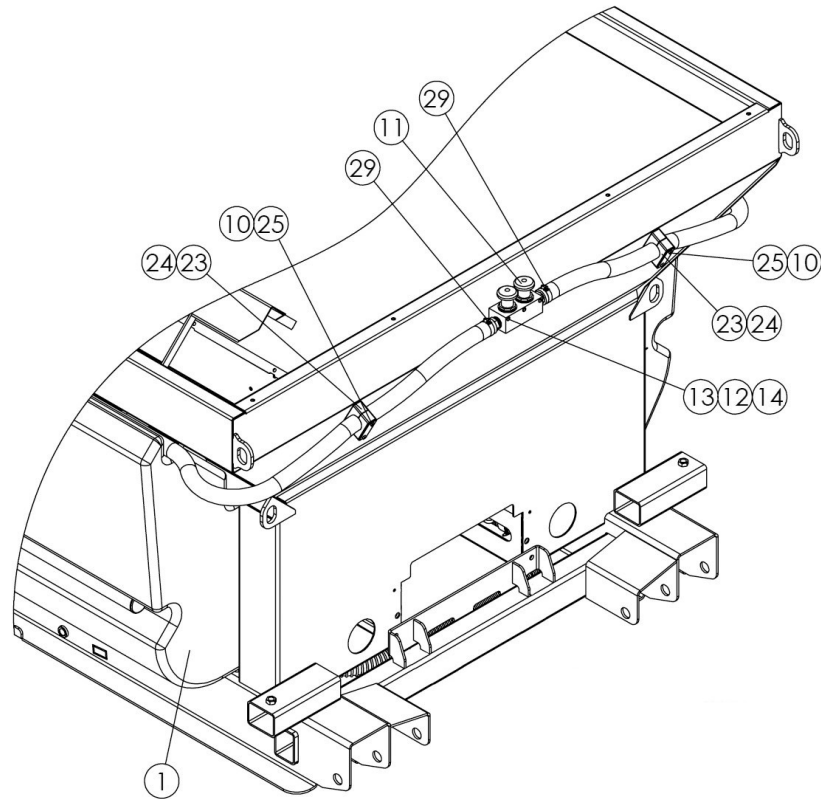

ITEM	PART NO.	DESCRIPTION	QTY
1	307937	Tank - 232gal 10'	2
	307938	Tank - 292gal 12'	2
	307939	Tank - 350gal 14'	2
2	308005	Buckle - Wldmt Turn 304	AR
3	308008	Rod - Threaded .50-13nc X 6 SS	AR
4	308009	Tube - 2.5od X 11ga X 84 10'	2
	308316	Tube - 2.5od X 11ga X 108 12'	2
	308317	Tube - 2.5od X 11ga X 132 14'	2
5	36416	Nut - Hex .5-13nc SS	AR
6	308010	Nut - Acorn .5-13nc SS	AR
7	308024	Plug - Poly 2.5od	4
8	36399	Capscrew - .375-16nc X 1.25 SS	AR



Liquid System

Liquid Tank Group

<u>ITEM</u>	<u>PART NO.</u>	<u>DESCRIPTION</u>	<u>QTY</u>
9	72054	Nut - Lock .375-16nc SS	AR
10	42034	Nut - Lock .25-20nc SS	4
11	308014	Vent - Assy Tank Poly	1
12	171052	Washer - Flat #10 SS	3
13	44398	Screw - Round Head #10-24nc X 3 SS	3
14	56355	Nut - Lock #10-24nc SS	3
15	307896	Fitting - Hose Barb 1.25 Hose	2
16	308021	Fitting - Hose Barb 1 Hose X 1.25 Mnpt Poly	2
17	308022	Fitting - Hose Barb 1 Hose X .75 Mnpt Poly	2
18	307922	Valve - Check 5 Psi 3/4 Fnpt	2
19	307902	Fitting - Plug .5 Npt Hex Head	3
20	308183	Float Switch - .5mnpt Side Mtg	1
21	307898	Fitting - Hose Barb 90° .5	2
22	308023	Float - Ball Poly	1
23	308165	Clamp Pair - 1.75 Tube	2
24	308164	Plate - Cover Clamp 1.75od	2
25	56396	Capscrew - .25-20nc X 3.25 SS	4
26	308027	Clamp - Hose Sae 8 SS	2
27	308170	Clamp - 2 Spiral Double Bolt	2
28	321849	Clamp - Hose Sae 16 SS	4
29	321799	Clamp - Hose Sae 24 SS	4
30	*96942	Tie - Wire Hd 29 Long	4
31	*308240	Loctite - Plastic Pipe Sealant	AR
32	*308241	Sealant - Rtv 732	AR
33	319192	Hose - Group 10'	1
	319193	Hose - Group 12'	1
	319194	Hose - Group 14'	1
34	84280	Strip - Rubber	AR
35	312454	Washer - Formed 304	4

AR - As Required



Liquid System

Liquid Tank Hose Group

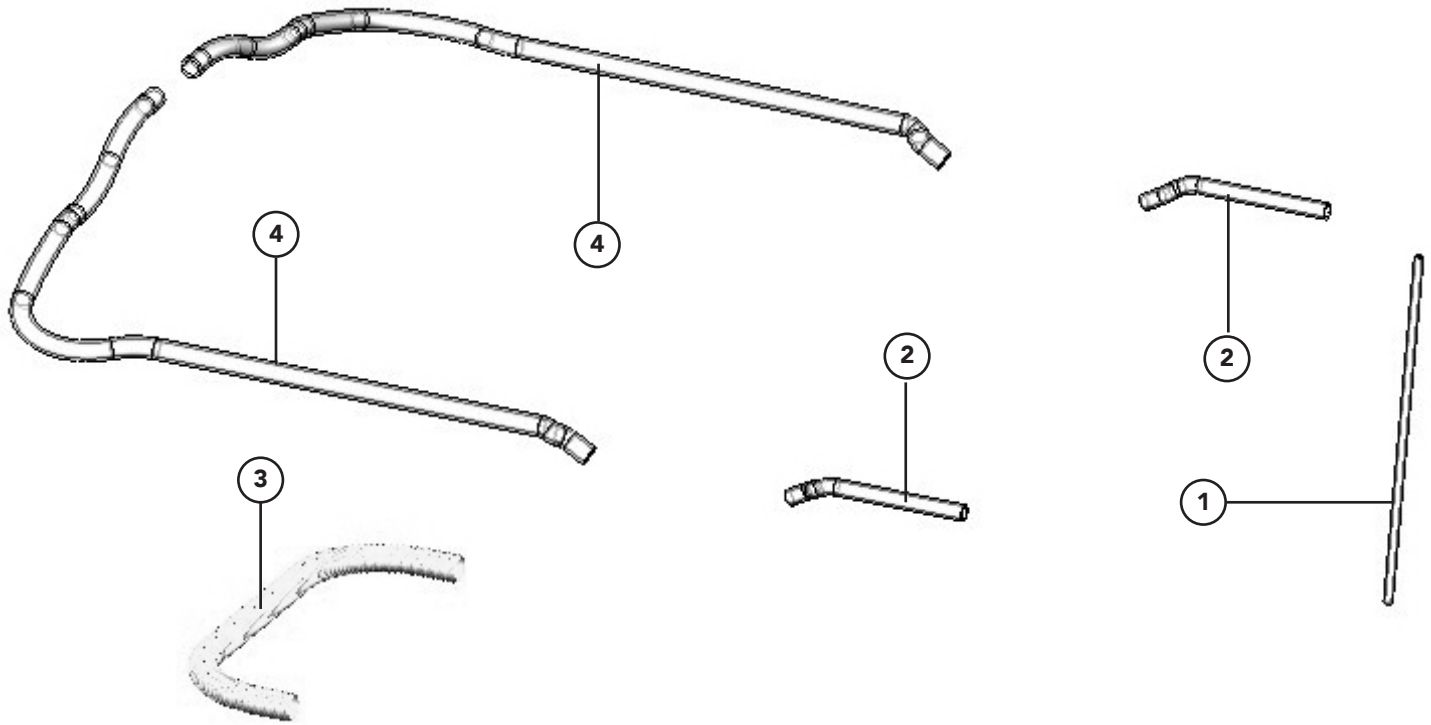

ITEM	PART NO.	DESCRIPTION	QTY		
			10'	12'	14'
1	307908	Hose - .5 Clear Pvc Sight	2.5'	2.5'	2.5'
2	307907	Hose - 1 Vaccum/Transfer Pvc	2.75'	2.75'	2.75'
3	308169	Hose - 2 Pvc	4'	4'	4'
4	307906	Hose - 1.25 Vac/Transfer Pvc	14.25'	16.2'	18.2'



Liquid System

Liquid - Assy Anti-ice

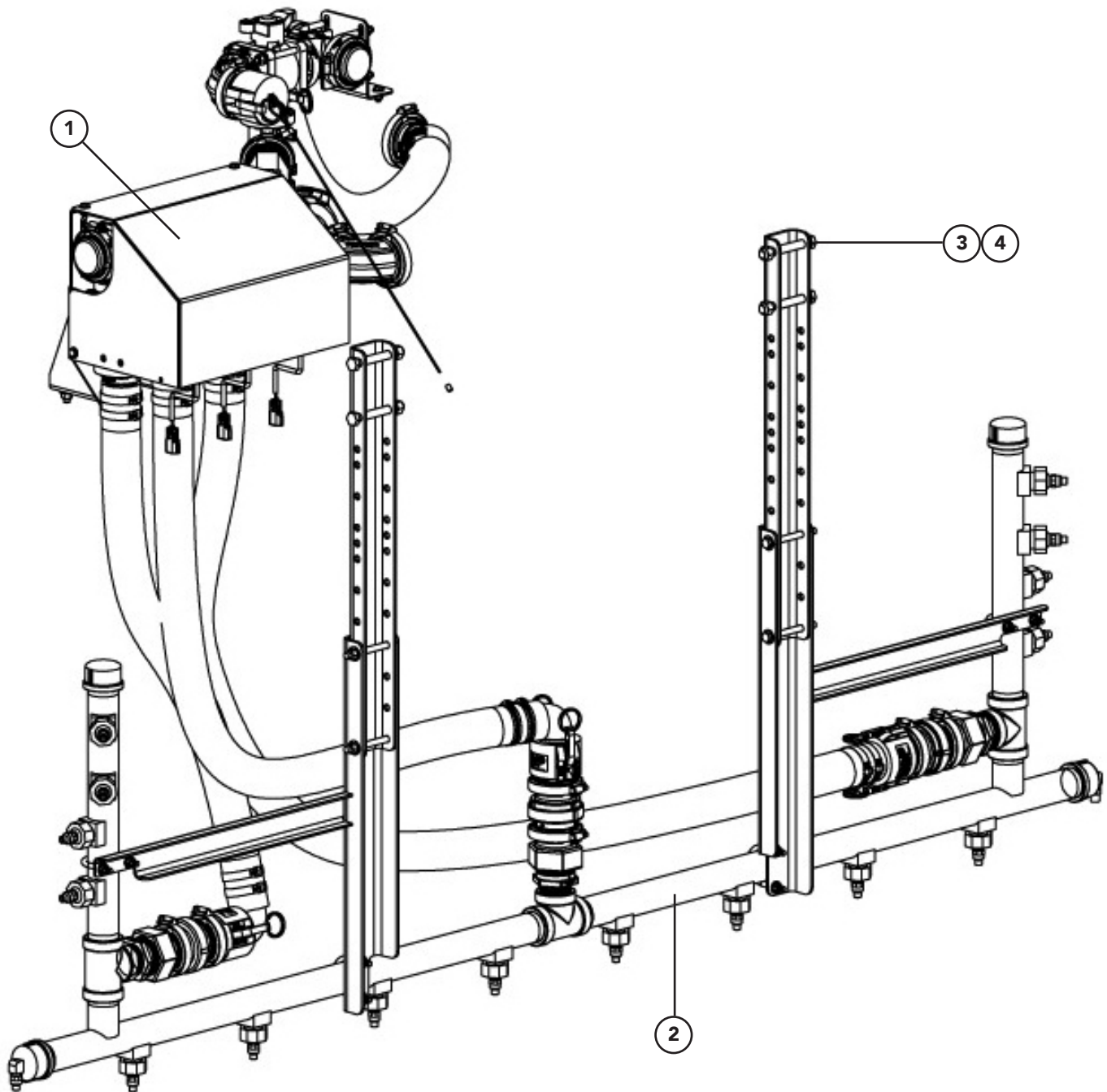

ITEM	PART NO.	DESCRIPTION	QTY
1	319199	Liquid - Assy Antiice	1
2	316942	Liquid - Group Spray Bar	1
3	36404	Capscrew - .5-13NC X 4 SS	4
4	39016	Nut - Lock .5-13NC SS	4



Liquid System

Liquid - Assy Anti-ice

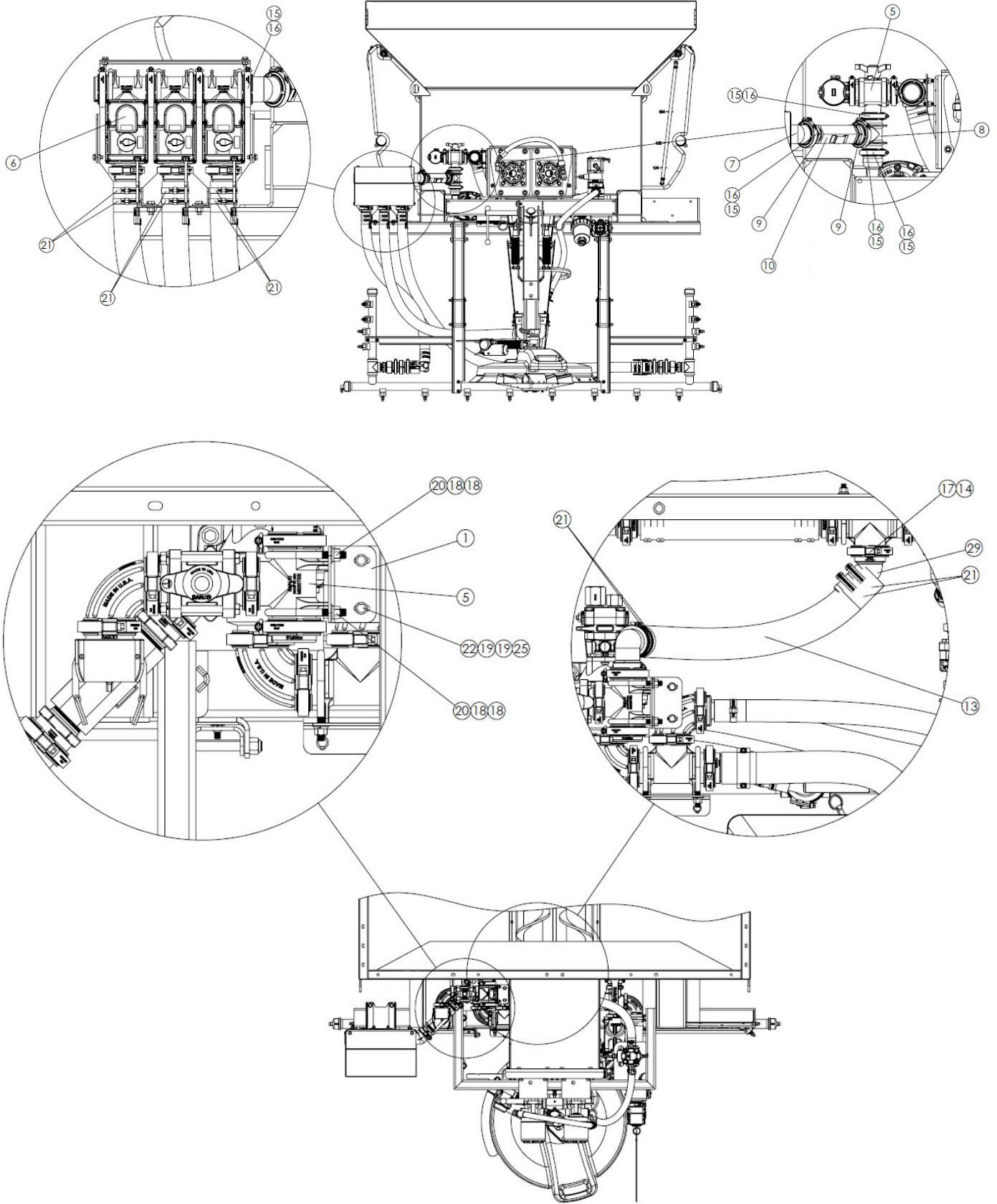

Liquid System

Liquid - Assy Anti-ice

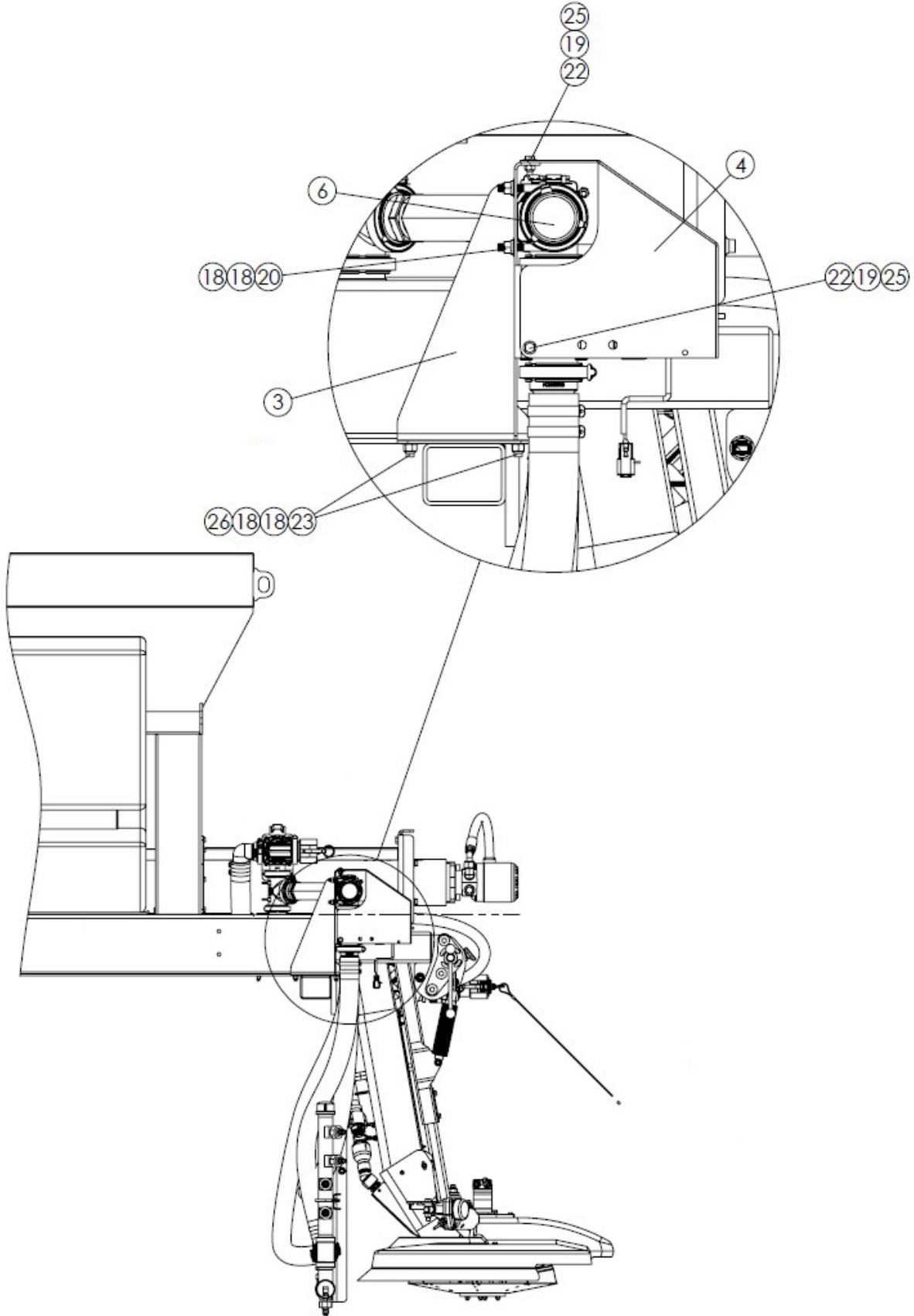

Liquid System

Liquid - Assy Anti-ice

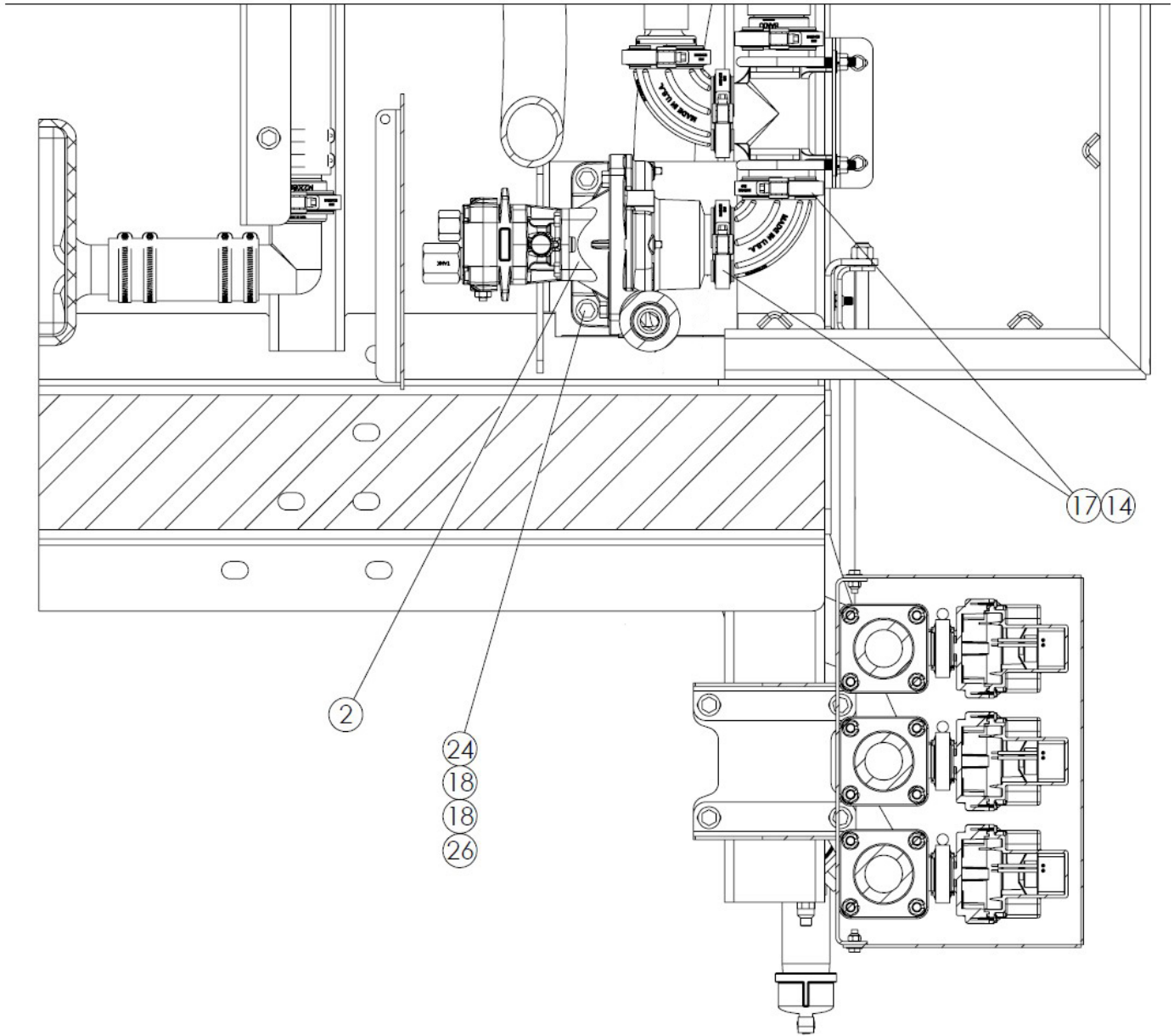

Liquid System

Liquid - Assy Anti-ice

ITEM	PART NO.	DESCRIPTION	QTY
1	316856	Bracket - Angle 304	1
2	322085	Pump - Centrifugal	1
3	316858	Mount - Wldmt Valve 304	1
4	317112	Cover - Wldmt	1
5	319200	Valve - Assy 3-Way Poly	1
6	316938	Valve - Assy Electric Poly	1
7	316827	Fitting - Elbow 45° Poly	1
8	316825	Fitting - Tee 2 Poly Manifold	1
9	316866	Fitting - Adapter 2 Manifold	2
10	316864	Sensor - Flowmeter	1
11	316906	Coupling - 2 Female X 2 Hose	1
12	316907	Coupling - 90° 2 Female X 2	2
13	319222	Hose - Group Antiice	1
14	316885	Gasket - 2fp Epdm	3
15	316829	Gasket - 1.5 Epdm	5
16	316830	Clamp - Worm 2 300 Series SS	5
17	316884	Clamp - Worm 2 300 Series SS	3
18	36425	Washer - Flat .375 SS	24
19	36423	Washer - Flat .25 SS	8
20	316831	U-Bolt - 2 18-8 SS	6
21	321848	Clamp- Hose T-Bolt SS	16
22	36393	Capscrew - .25-20nc X .75 SS	6
23	36398	Capscrew - .375-16nc X 1 SS	4
24	34858	Capscrew - .375-16nc X 1.5 SS	2
25	42034	Nut - Lock .25-20nc SS	6
26	72054	Nut - Lock .375-16nc SS	6
27	308240	Loctite - Plastic Pipe Sealant	AR
28	316874	Fitting - Sweep 90° 2fp	1
29	316882	Fitting - Hose Barb 45° 2fp	1

AR - As Required



Liquid System

Liquid - Assy Anti-ice Spraybar

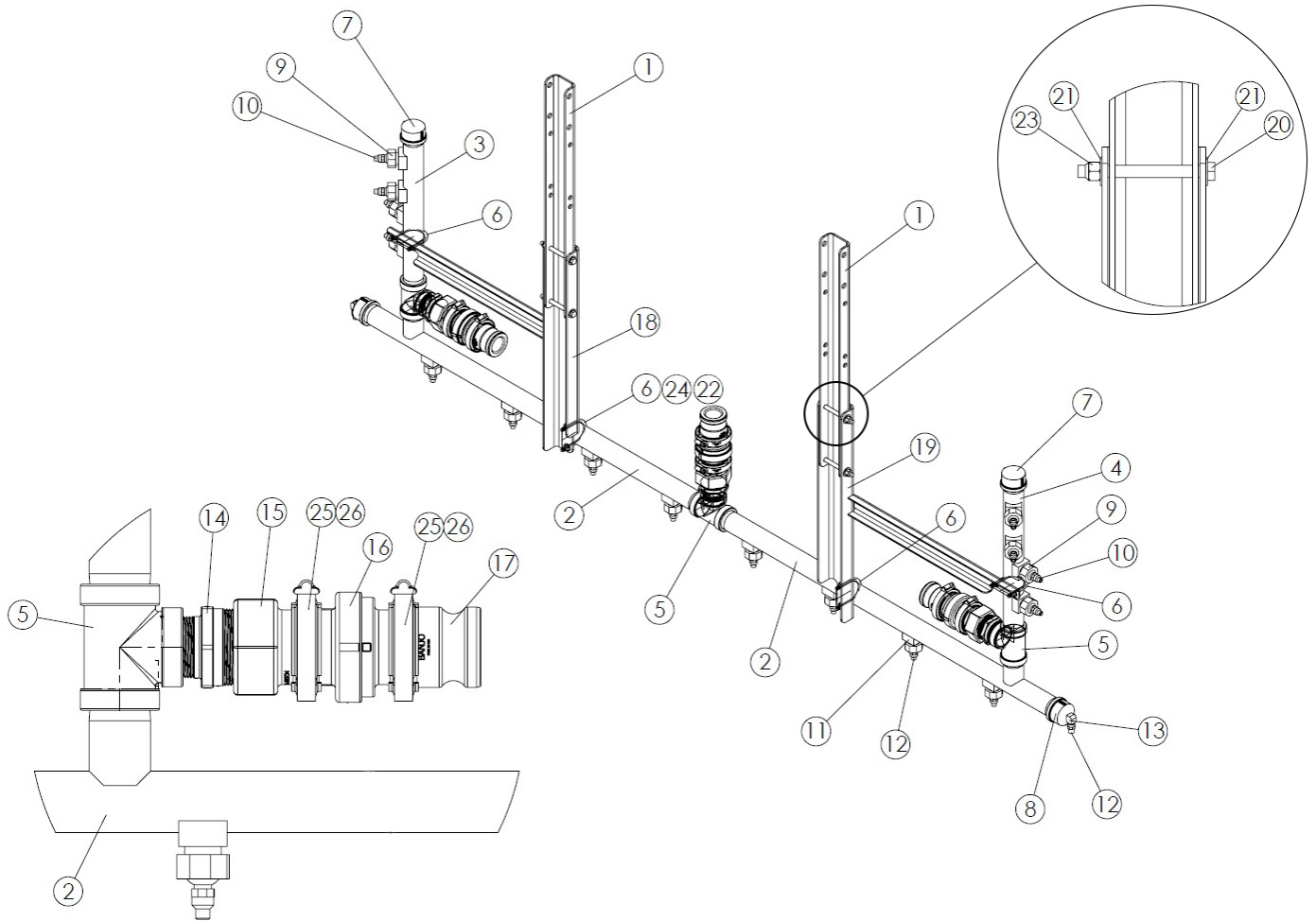

Liquid System

Liquid - Assy Anti-ice Spraybar

ITEM	PART NO.	DESCRIPTION	QTY
1	316715	Leg - Upper 304	2
2	316917	Spray Bar - Wldmt 304	2
3	316706	Pipe - Spray Lh 304	1
4	316707	Pipe - Spray Rh 304	1
5	316711	Pipe - Tee 304	3
6	316727	U-Bolt - 2 304	4
7	316708	Pipe - Cap 304	2
8	316709	Cap - Pipe Tapped 304	2
9	316730	Nozzle - Quick Attach .375	8
10	316728	Nozzle - .375 Brass	8
11	316731	Nozzle - Quick Attach .25	8
12	316729	Nozzle - .25 Brass	10
13	316732	Elbow - .25 Brass	2
14	316909	Fitting - Nipple Reducing 2	3
15	316826	Fitting - 2 Fnpt Poly	3
16	316908	Valve - Check .5 Pso 2	3
17	316870	Fitting - Adapter 2 Manifold	3
18	316916	Support - Wldmt Lh 304	1
19	316915	Support - Wldmt Rh 304	1
20	34860	Capscrew - .375-16nc X 4 SS	4
21	36425	Washer - Flat .375 SS	8
22	36424	Washer - Flat .313 SS	8
23	72054	Nut - Lock .375-16nc SS	4
24	42221	Nut - Lock .313-18nc SS	8
25	316830	Clamp - Worm 2 300 Series SS	6
26	316829	Gasket - 1.5 Epdm	6
27	*308240	Loctite - Plastic Pipe Sealant	AR
28	*00166	Loctite - Thread Sealant #565	AR
* Not Shown AR - As Required			

Liquid System

Valve - Assy 3-Way Poly

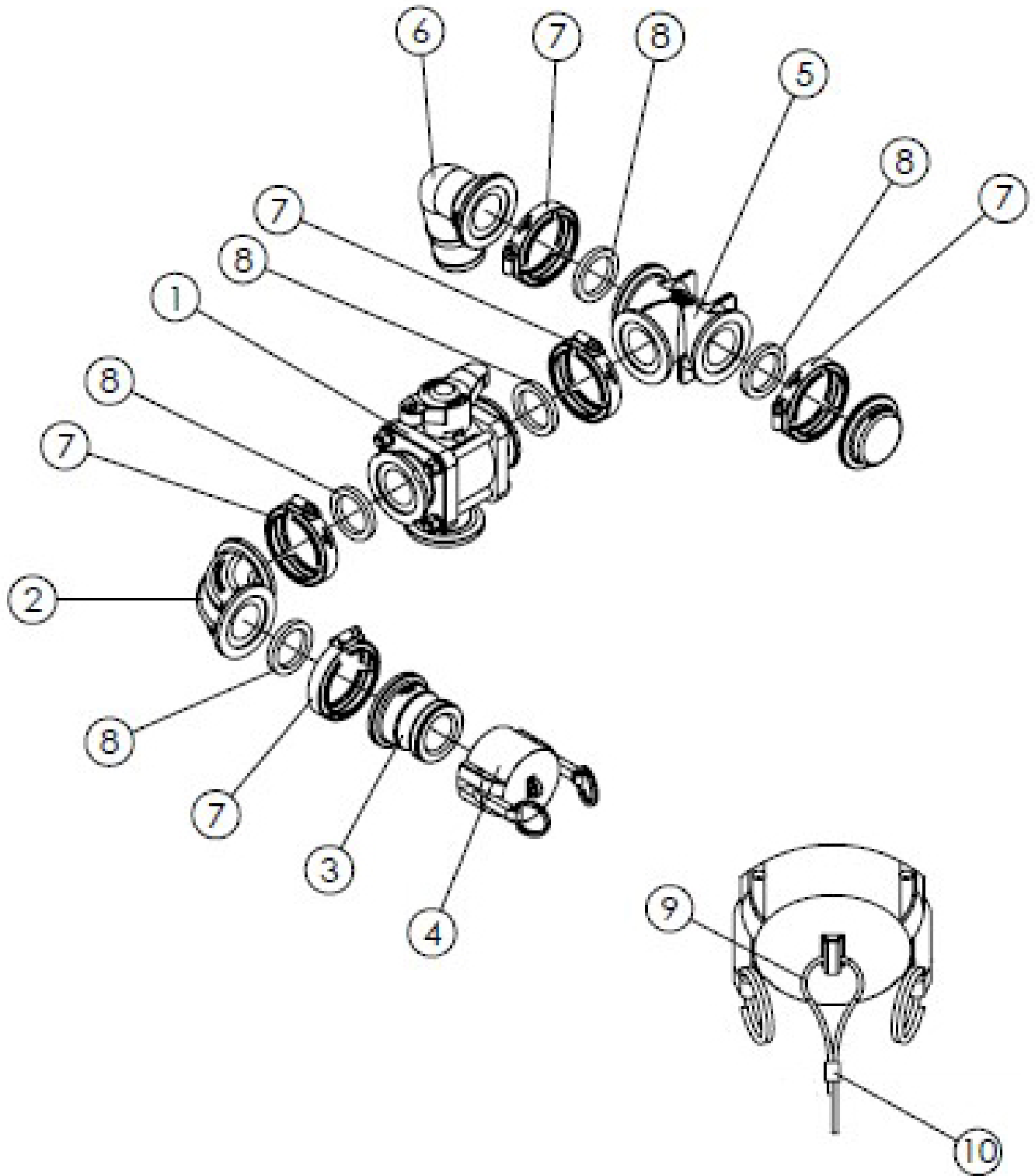

Liquid System

Valve - Assy 3-Way Poly

ITEM	PART NO.	DESCRIPTION	QTY
1	316715	Leg - Upper 304	2
2	316917	Spray Bar - Wldmt 304	2
3	316706	Pipe - Spray Lh 304	1
4	316707	Pipe - Spray Rh 304	1
5	316711	Pipe - Tee 304	3
6	316727	U-Bolt - 2 304	4
7	316708	Pipe - Cap 304	2
8	316709	Cap - Pipe Tapped 304	2
9	316730	Nozzle - Quick Attach .375	8
10	316728	Nozzle - .375 Brass	8
11	316731	Nozzle - Quick Attach .25	8
12	316729	Nozzle - .25 Brass	10
13	316732	Elbow - .25 Brass	2
14	316909	Fitting - Nipple Reducing 2	3
15	316826	Fitting - 2 Fnpt Poly	3
16	316908	Valve - Check .5 Pso 2	3
17	316870	Fitting - Adapter 2 Manifold	3
18	316916	Support - Wldmt Lh 304	1
19	316915	Support - Wldmt Rh 304	1
20	34860	Capscrew - .375-16nc X 4 Ss	4
21	36425	Washer - Flat .375 Ss	8
22	36424	Washer - Flat .313 Ss	8
23	72054	Nut - Lock .375-16nc Ss	4
24	42221	Nut - Lock .313-18nc Ss	8
25	316830	Clamp - Worm 2 300 Series Ss	6
26	316829	Gasket - 1.5 Epdm	6
27	*308240	Loctite - Plastic Pipe Sealant	AR
28	*00166	Loctite - Thread Sealant #565	AR
* Not Shown AR - As Required			



Liquid System

Valve - Assy Electric Poly

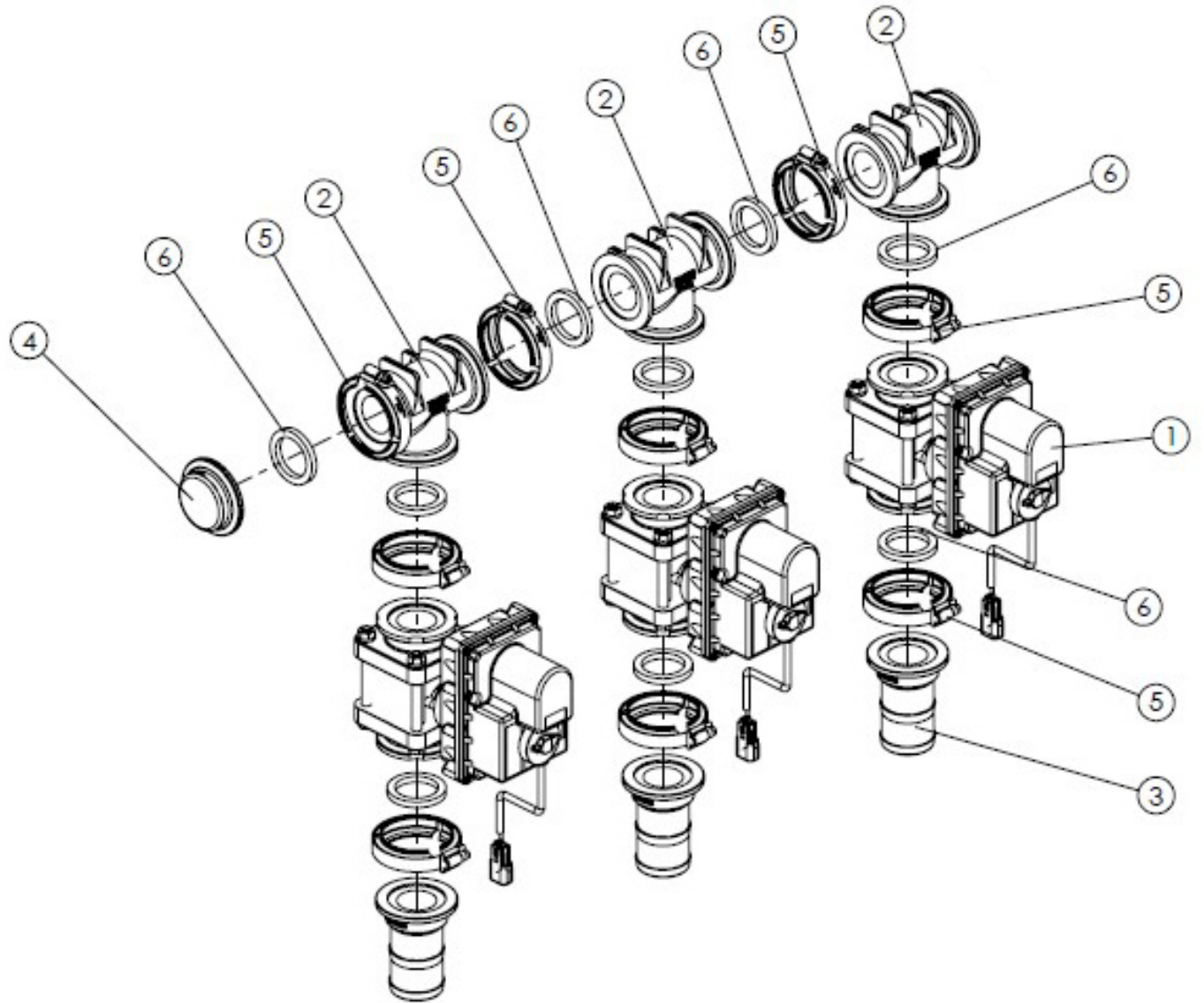

Liquid System**Valve - Assy Electric Poly**

<u>ITEM</u>	<u>PART NO.</u>	<u>DESCRIPTION</u>	<u>QTY</u>
1	316868	Valve - 3-Way 2 Manifold	1
2	316869	Fitting - Adapter 90° 2	1
3	316870	Fitting - Adapter 2 Manifold	1
4	307913	Dust Cap - 2 Camlock Poly	1
5	316825	Fitting - Tee 2 Poly Manifold	1
6	316871	Fitting - Hose Barb 90° 2	1
7	316830	Clamp - Worm 2 300 Series SS	5
8	316829	Gasket - 1.5 Epdm	5
9	308084	Cable - .094 X 24 Coated	1
10	308085	Ferrule - .185 X .374	2
11	316883	Fitting - Plug 2 Manifold	1



Liquid System

Hose Group

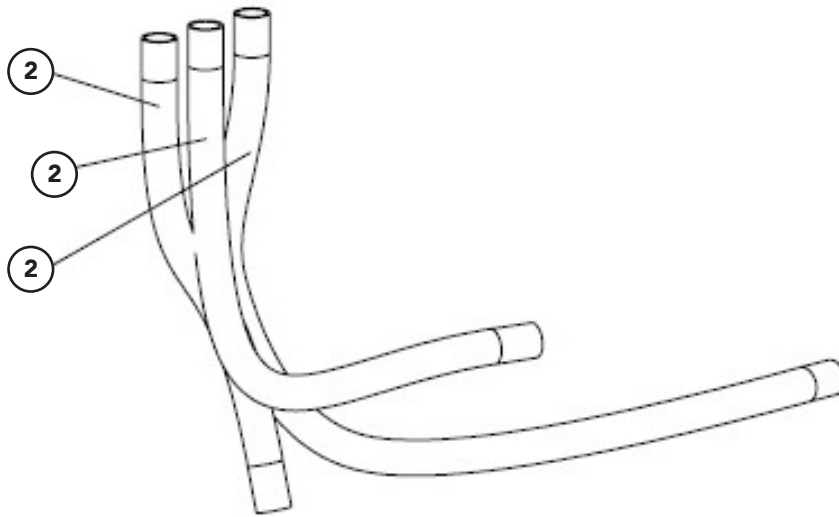

<u>ITEM</u>	<u>PART NO.</u>	<u>DESCRIPTION</u>	<u>QTY</u>
1	307905	Hose - 2 Vaccum/Transfer Pvc	2.3'
2	316923	Hose - 2 Suction/Descharge	16'



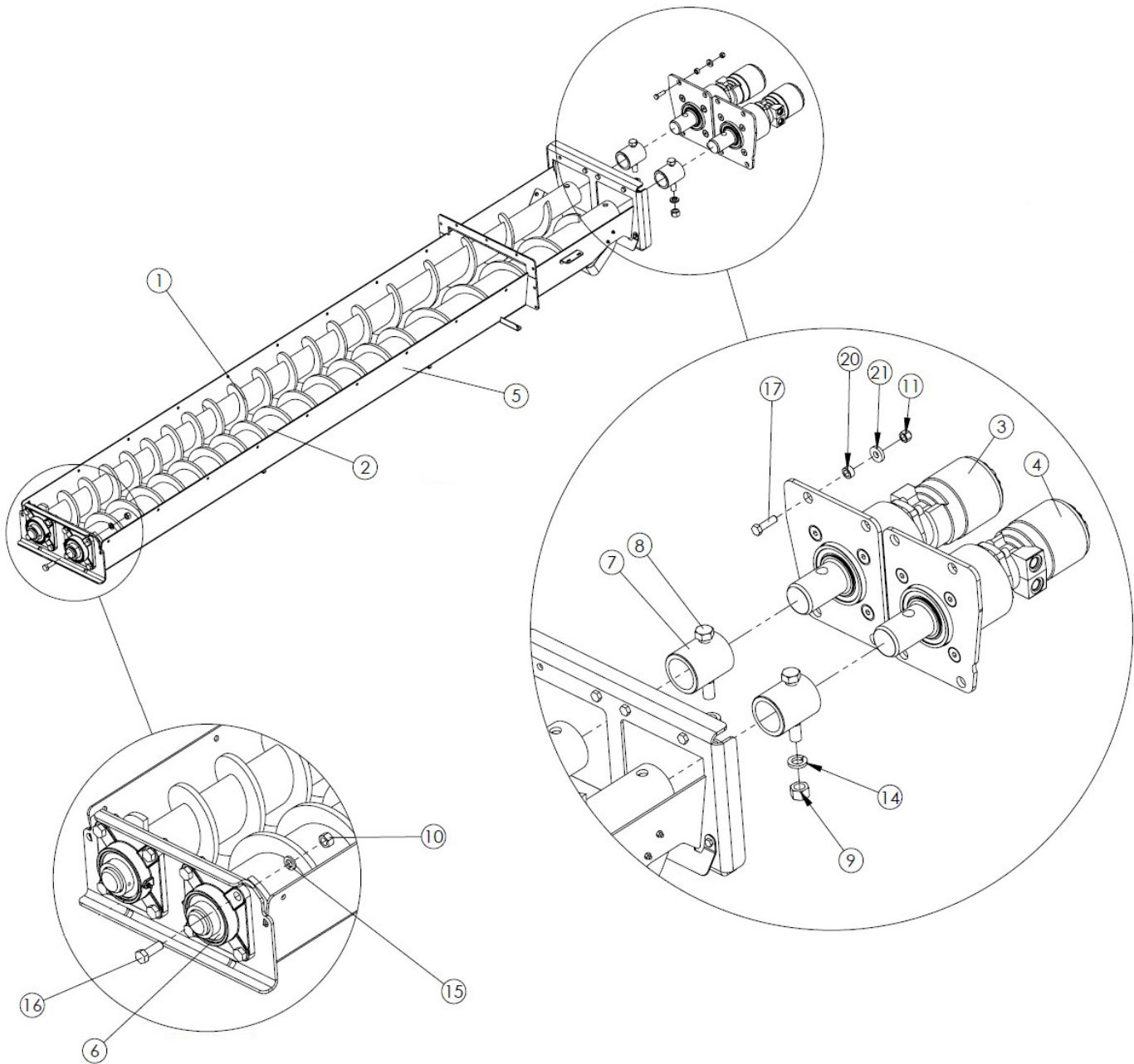

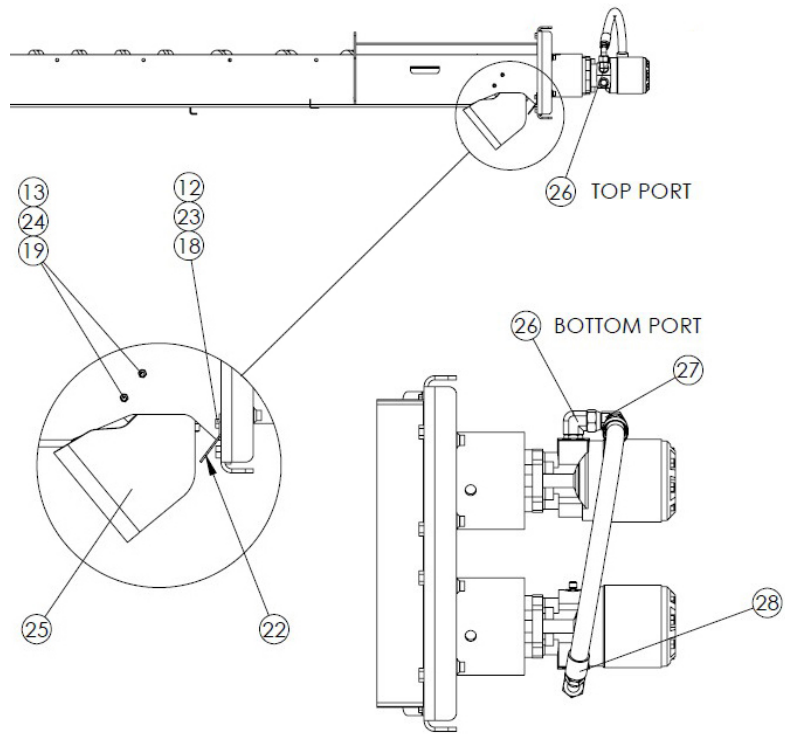

Auger Drive Assembly

ITEM	PART NO.	DESCRIPTION	QTY
1	317497	RH Auger - Wldmt 10' X 7OD	1
	317913	RH Auger - Wldmt 12' X 7OD	1
	316567	RH Auger - Wldmt 14' X 7OD	1
2	317496	LH Auger - Wldmt 10' X 7OD	1
	317912	LH Auger - Wldmt 12' X 7OD	1
	316568	LH Auger - Wldmt 14' X 7OD	1
3	316622	Drive - Assy Auger RH	1
4	316621	Drive - Assy Auger LH	1
5	319130	Bottom - 10' 304	1
	319134	Bottom - 12' 304	1
	316634	Bottom - 14' 304	1
6	6465	Bearing - 4bf 2 Bore	2
7	314143	Insert - Drive Auger Tube	2
8	314138	Bolt - Coupling .875 -9 Unc X 5.5 304	2
9	314139	Nut - Lock .875-9nc SS	2
10	36417	Nut - Hex .625-11nc SS	8
11	39016	Nut - Lock .5-13nc SS	8
12	72054	Nut - Lock .375-16nc SS	2
13	42034	Nut - Lock .25-20nc SS	4
14	314140	Washer - Lock .875 SS	2
15	40597	Washer - Lock .625 SS	8
16	58800	Capscrew - .625-11nc X 1.75 SS	8
17	71832	Capscrew - .5-13nc X 1.75 SS	8
18	36398	Capscrew - .375-16nc X 1 SS	2
19	36393	Capscrew - .25-20nc X .75 SS	4
20	314142	Bushing - Drive 304	8
21	314144	Washer - Drive Plate 304	8
22	316769	Lip - Rear Deflector 304	1
23	36425	Washer - Flat .375 SS	2
24	36423	Washer - Flat .25 SS	4
25	316801	Chute - Conveyor 304	1



Auger Drive Assembly

<u>ITEM</u>	<u>PART NO.</u>	<u>DESCRIPTION</u>	<u>QTY</u>
26	29773	Fitting - 12-10 070220	2
27	34709	Fitting - 12-12 070221	1
28	318223	Hose - Assy .75 X 26 100r12	1



Auger Drive Assembly Installation

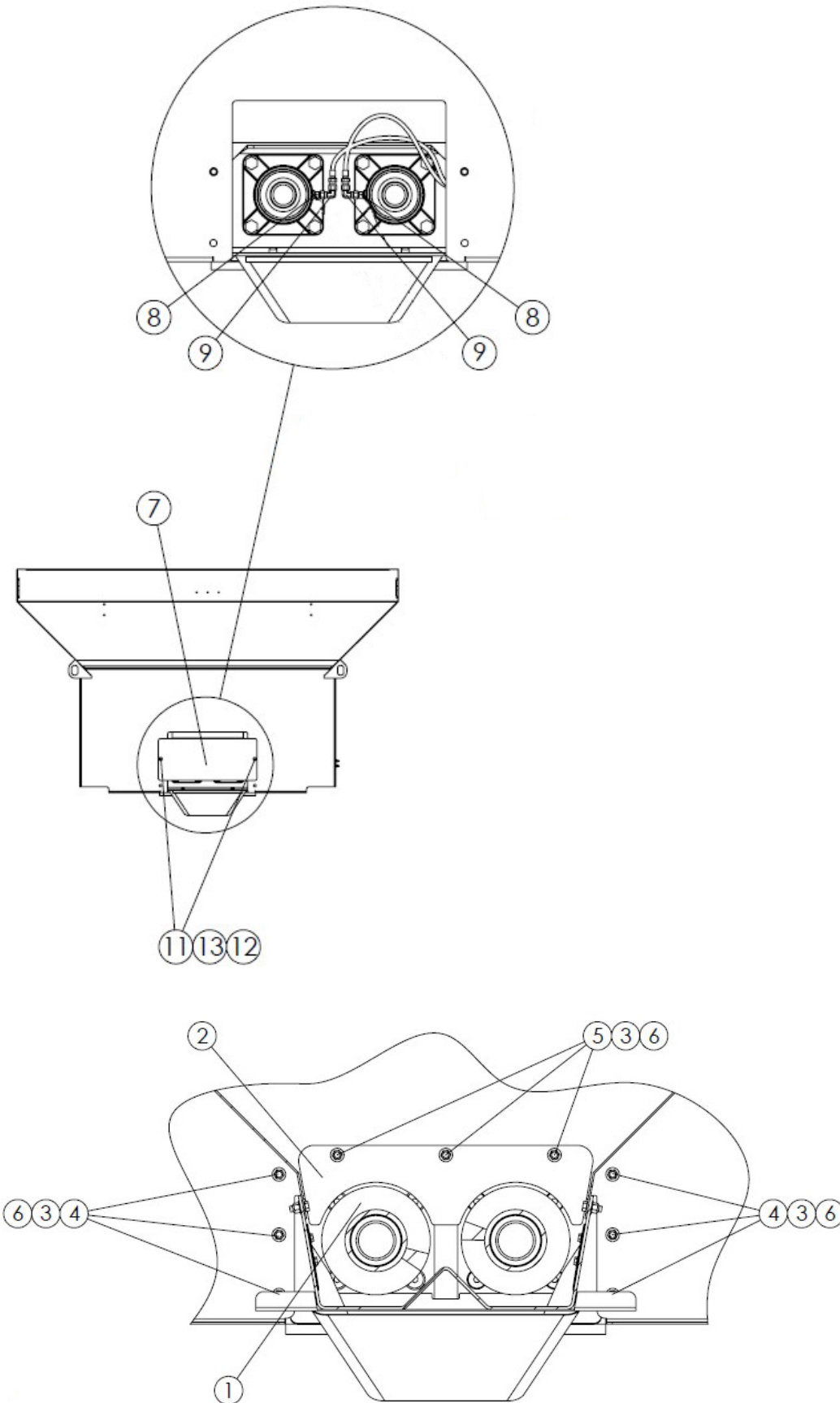

Auger Drive Assembly Installation

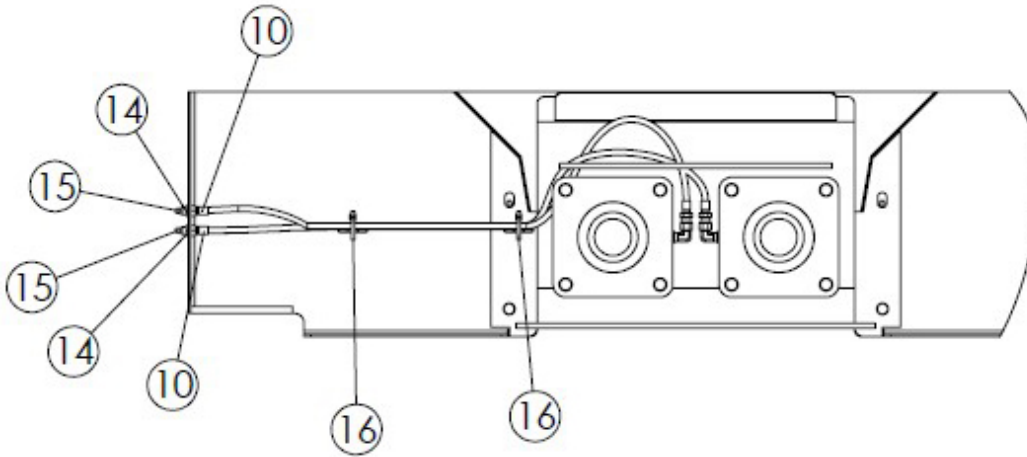

ITEM	PART NO.	DESCRIPTION	QTY
1	319129	Auger - Assy 10'	1
	319133	Auger - Assy 12'	1
	316626	Auger - Assy 14'	1
2	316813	Plate - Weir 304	1
3	36425	Washer - Flat .375 SS	27
4	36398	Capscrew - .375-16nc X 1 SS	24
5	36399	Capscrew - .375-16nc X 1.25 SS	3
6	72054	Nut - Lock .375-16nc SS	27
7	316843	Cover - Bearing Access 304	1
8	34787	Fitting - 4-2 070102	2
9	34868	Fitting - 4-4 070221	2
10	316849	Hose - Assy .125 X 33 Hlb	2
11	36393	Capscrew - .25-20nc X .75 SS	2
12	36423	Washer - Flat .25 SS	2
13	36418	Washer - Lock .25 SS	2
14	310471	Nut - Bulkhead .125-27	2
15	311663	Zerk - Grease .25-28 Straight	2
16	99674	Strap - Zip Tie 8 Black	2

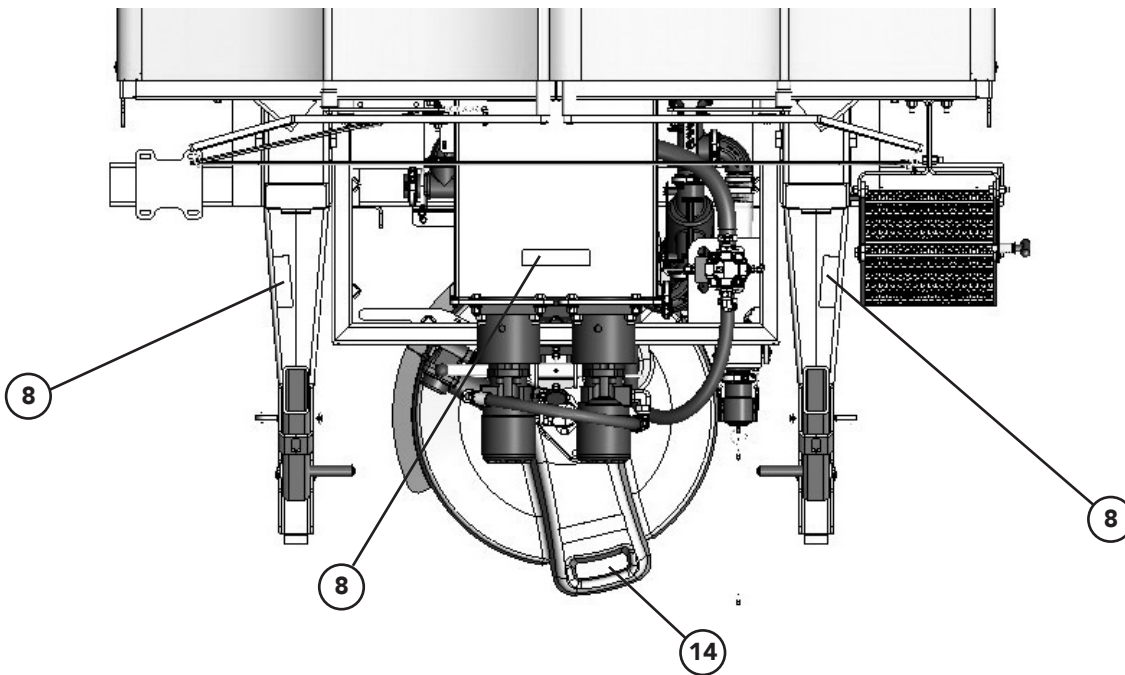
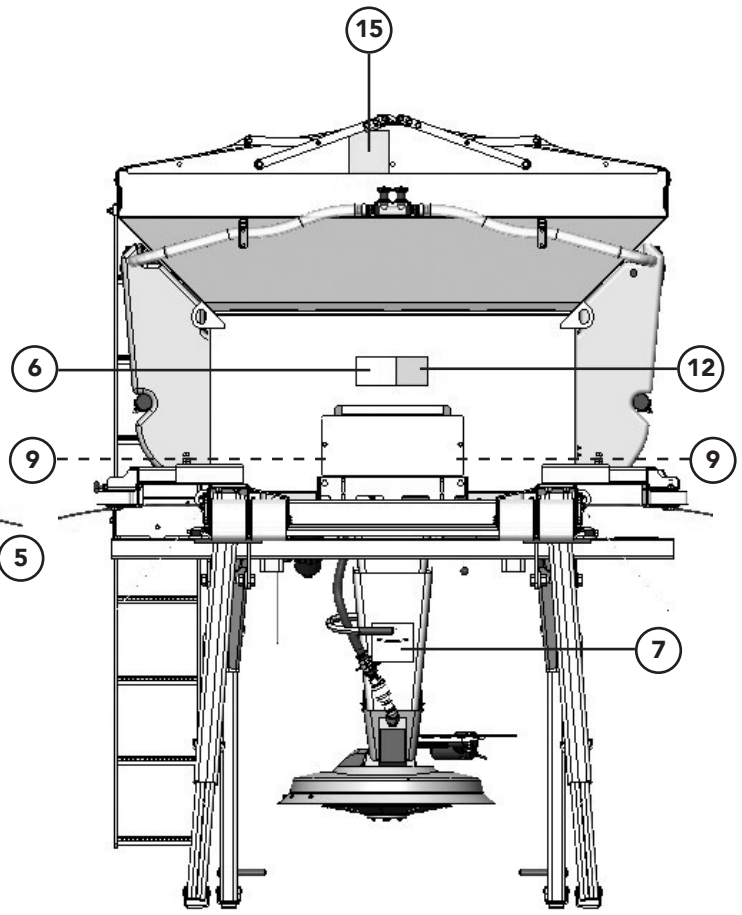
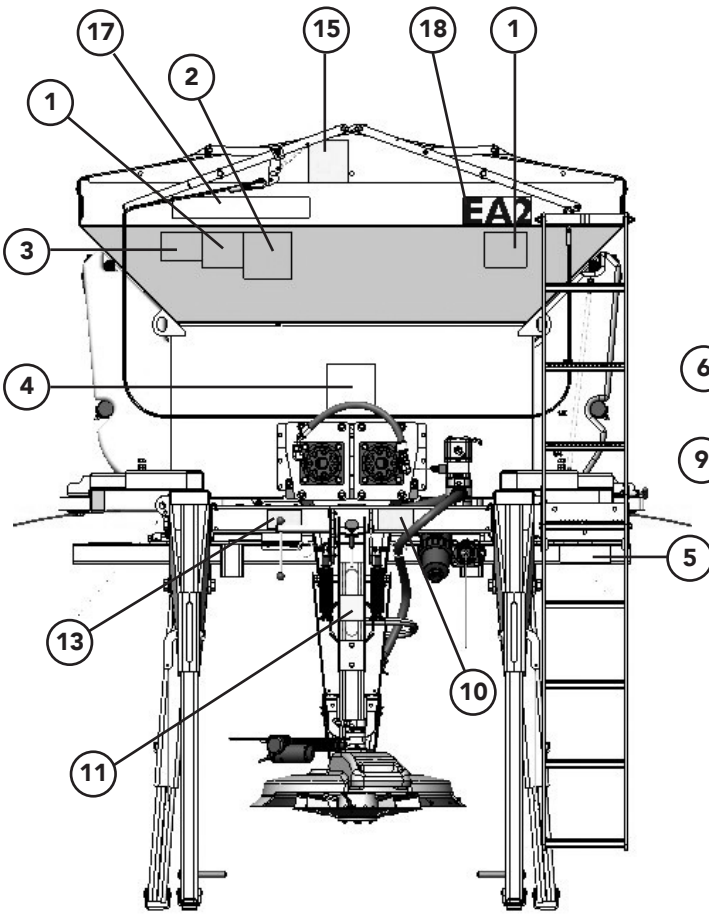

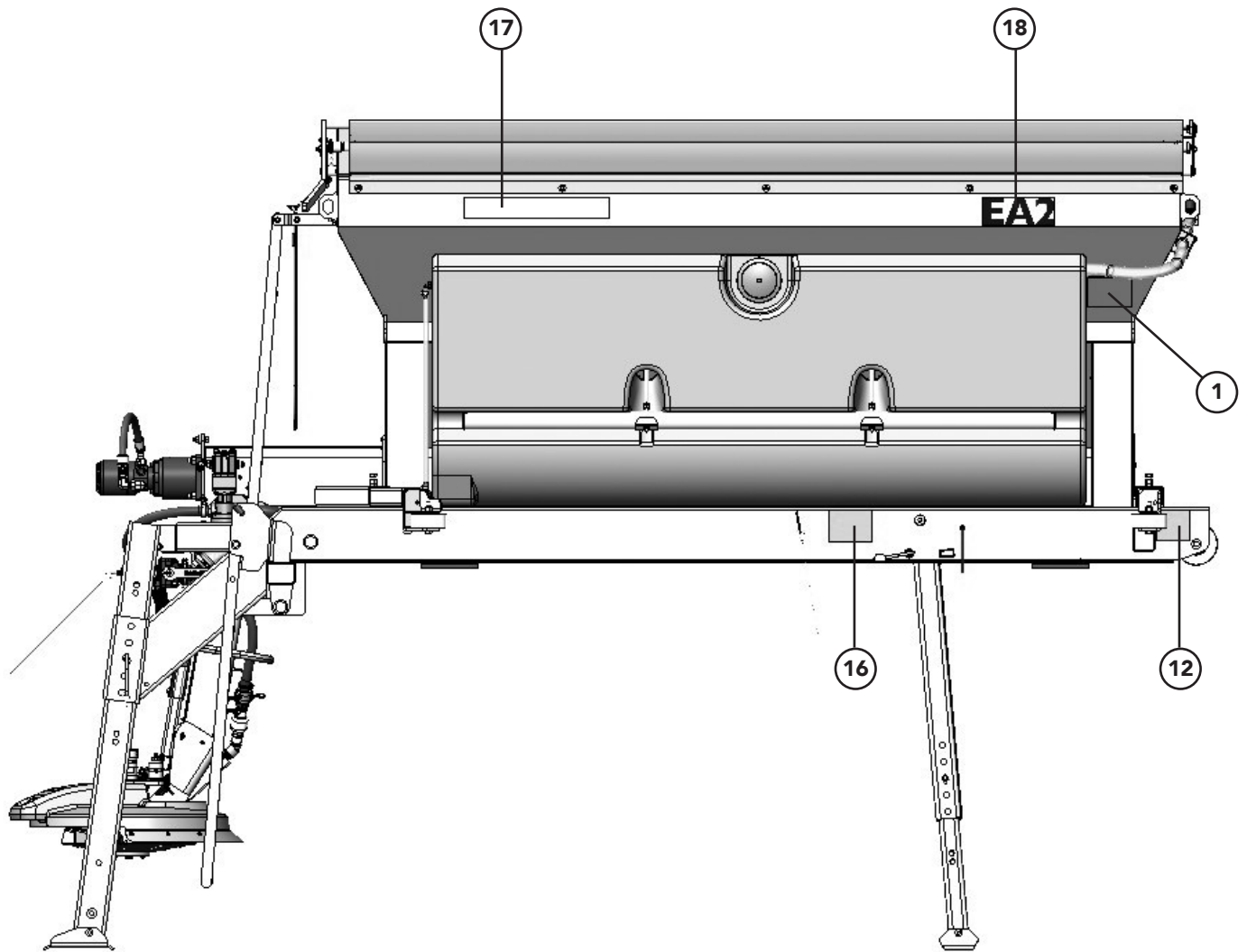

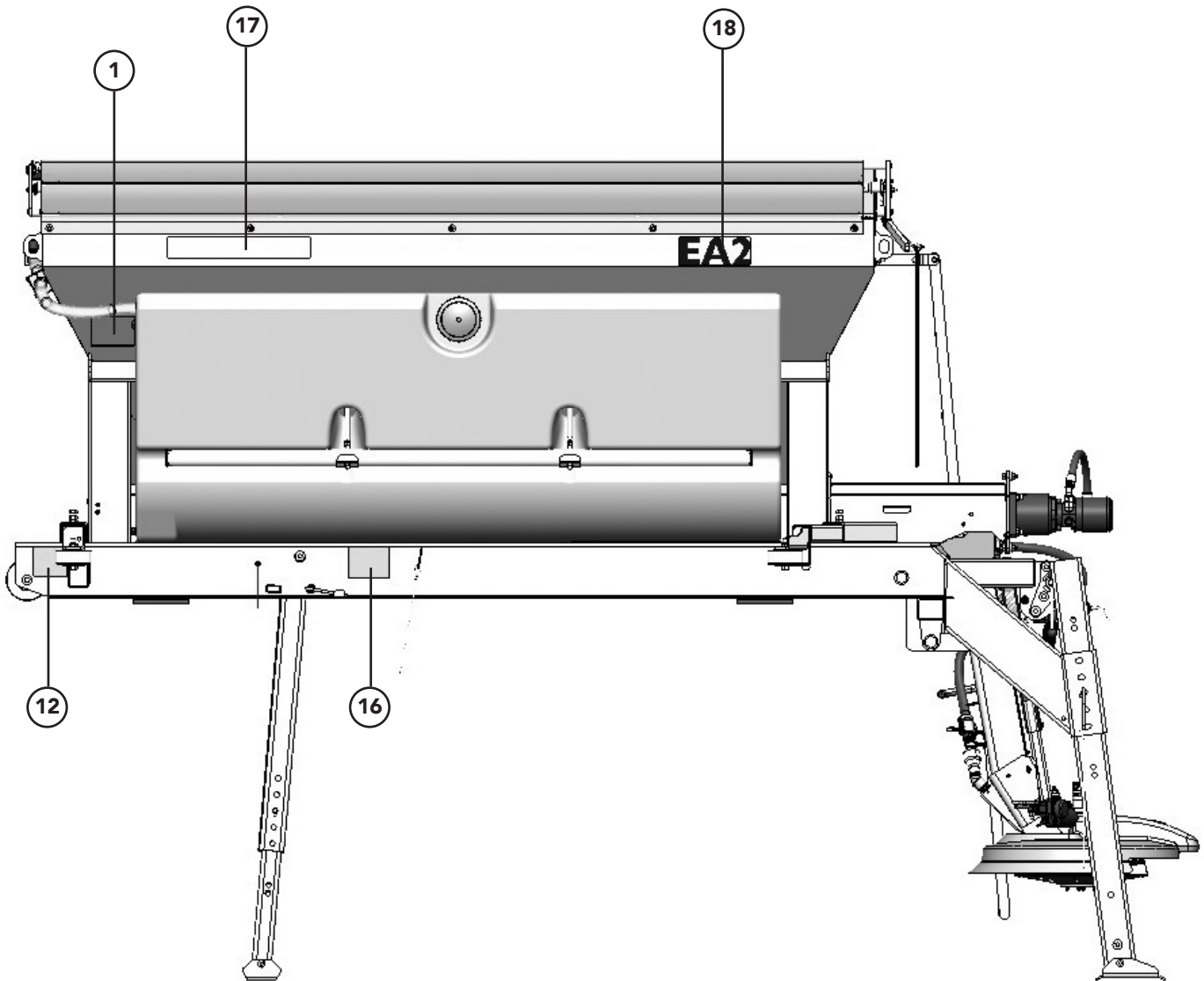

Decals

ITEM	PART NO.	DESCRIPTION	QTY
1	55997	Decal - Danger Moving Part	4
2	150034	Decal - Caution Oper & Maint	1
3	321	Decal - Caution Hazard Matl	1
4	39138	Decal - Warning High Pressure	1
5	305274	Decal - Warning Falling Hazard	1
6	55631	Decal - Warning Moving Part	1
7	71807	Decal - Warning Falling	1
8	39017	Decal - No Step	3
9	308191	Decal - Guard Is Missing	2
10	308192	Decal - Danger Flying Material	1
11	308193	Decal - Falling Hazard	1
12	308194	Decal - Danger Crushing Hazard	1
13	308196	Decal - Read Manual	1
14	308199	Decal - No Step	1
15	55241	Decal - Danger Pinch Point Hazard	2
16	308195	Decal - Lock Leg	2
17	315810	Decal - Hiway 3 Black	3
18	319223	Decal - Decor Ea2	3



This page is intentionally left blank.