



L4000 G4
Operator's/Parts Manual

UNIT SERIAL NO. _____

MULTAPPLIER/MULTIBIN SERIAL NO. _____

MANUAL NUMBER: 307074-K

EFFECTIVE 01/2025



1330 76TH AVE SW
CEDAR RAPIDS, IA 52404-7052
PHONE (800) 363-1771 | FAX (319) 286-3350
www.newleader.com

Copyright 2025 New Leader Manufacturing

Table of Contents

Interactive Features	6
Warranty	8
Preface	9
Safety	10
Important Safety Information	10
Safety Alert Symbols	10
General Safety Rules	11
Safety Decals	21
Safety Decal Maintenance	21
Safety Decal Installation	21
Installation Instructions	27
Hydraulic Requirements	27
Truck Requirements	27
Lifting the Spreader	28
Installing Body	29
Securing to Frame	30
Fender Installation	31
Hydraulic Hose Installation	33
Hydraulic Pump Installation	33
Hydraulic Hose Installation Guide	34
Filling Hydraulic System	35
Hydraulic Drain Lines	35
Electrical Connections	35
Light Installation	35
Insert Installation	36
Hydraulic Requirements	36
Spreader Preparation	37
Feedgate Adjustment	40
Insert Installation	41
Lower Divider - Multibin	44
Hillside Divider & Conveyor Cover - MultApplier	46
Micro Cover Installation	47
Hydraulics	49
Hydraulic Hose Installation	50
Install Valve Bracket	51
Install Valve	51
Install Clamp Assemblies	52
Insert Removal/Endgate Installation	56
Operations	59
Introduction	60
Initial Startup	70
G4 Spinner Squaring	71
Field Testing	75
General Operating Procedures	76

Maintenance 77

- Preventative Maintenance Pays! 77
- Hydraulic System 77
- Service Schedule 77
- Conveyor Gearcase 78
- Hydraulic Hose 78
- Conveyor Chain 79
- Conveyor Belt Maintenance 80
- Bin Sensor 81
- Lubrication of Bearings 81
- Fasteners 81
- Clean-Up 81
- Spinner Fins 82
- Spinner Deflectors 82
- Material & Hillside Flow Dividers 82
- Lubricant & Hydraulic Oil Specifications 83

 - Hydraulic System 83
 - Gearcase Lubricant 83
 - Grease Gun Lubricant 83

- Lubrication & Maintenance Chart 84

 - Chain Conveyors 84

- Troubleshooting 86

 - MultiBin Cover Air Schematic 88

- Standard Torques 89
- Pre- and Post-Season Check Lists 90

Hydraulics 91

- MultApplier Ready Hydraulic Schematic 92
- MultApplier Ready Hydraulic Flow Diagram 93
- Hi Performance MultApplier Ready Hydraulic Schematic 94
- Hi Performance MultApplier Ready Hydraulic Flow Diagram 95
- MultApplier Complete Hydraulic Schematic 96
- MultApplier Complete Hydraulic Flow Diagram 97
- Hi Performance MultApplier Complete Hydraulic Schematic 98
- Hi Performance MultApplier Complete Hydraulic Flow Diagram 99
- MultiBin Complete Hydraulic Schematic 100
- MultiBin Complete Hydraulic Flow Diagram 101

Spread Pattern 103

- Catch Test 103
- Spread Pattern 104
- Spread Pattern Test Kit 104
- Spinners 105
- Spreader Preparation 105
- Test Procedure 107
- Test Results 109
- Troubleshooting 110
- Determining Driving Centers 111
- Verifying Driving Centers 112

Table of Contents

Parts	113
Mounting Angle.....	114
Pads-Group.....	116
Body.....	117
Inverted "V"	117
Sight Window	118
Side Boards - Single Bin	119
Endgate, Feedgate & Jack	121
Fenders- Full Flotation Tires.....	123
Fenders - Super Flotation Tires.....	129
Fenders - Super Flotation Tires w/ 120" Straight Flare.....	131
Gauge Kit	133
Bin Sensor	135
Body Hydraulics.....	137
Standard Hydraulics	137
Hi Performance Hydraulics.....	143
Hydraulic Reservoir w/Cooler.....	149
Hydraulic Reservoir	153
Hydraulic Cooler	155
Standard Hydraulics - 4.38 CID Pump	157
Standard Hydraulics - 4.46 CID Tandem Pump.....	159
Hi Performance Pump Hydraulics	161
Spinner Hydraulics.....	163
Assembly.....	163
Spinner Control Valve - Style B	165
Conveyor	167
#3 PintleChain Conveyor	167
#4 Belt-Over-Chain Conveyor	168
Conveyor Chain Shields.....	169
Conveyor Idler	172
Conveyor Drive.....	174
Gearcase - Dual Pinion Assembly Standard Hydraulics.....	176
Gearcase - Dual Pinion Assembly Hi Performance Hydraulics.....	177
Gear Case Breather Tube	179
Encoder.....	180
Cover	181
Conveyor Chain Oiler	182
Wiper Front.....	188
Rear Wiper - #3 Conveyor	189
Decals	190
Spinner	192
Spinner - Material Divider.....	192
Hillside Divider	193
Anti-Slab.....	194
Spinner Assembly.....	196
Disc Assembly.....	202
Spinner Guards & Deflectors.....	204
Spinner Speed Sensors.....	205

Table of Contents

MultiApplier	207
Body	207
Rear Feedgate - Style I	208
Rear Feedgate - Style II	209
Front Feedgate & Wiper - Style I	210
Front Feedgate & Wiper- Style II	211
Sealer - Style I	212
Sealer - Style II	213
Hillside Divider & Cover - Style I	214
Hillside Divider & Cover - Style II	215
#4 Belt-Over-chain Conveyor	216
Chain Shields	217
Conveyor Drive & Encoder	218
Idler	219
Idler Grease Zerks	220
Mounts	221
Hydraulics	222
Decals	225
Multibin	227
Mounting Hardware	227
Mounting Pads	227
Feedgate	228
Front Feedgate & Wiper	230
Sealer-Front	231
#4 Belt-Over-Chain Conveyor	232
Conveyor Drive & Encoder	233
Conveyor Idler	234
Chain Shields	235
Divider Panel - Single Micro	236
Divider Panel - Dual Micro	237
Hydraulics	238
Idler Zerk	242
Divider	243
Rear Feedgate	244
Micro Group	245
Micro Assembly-Single	247
Micro Assembly-Dual	249
Micro Assembly-Meter Wheels	251
Micro Screens	253
Cover Group	254
Cover Assembly	255
Air Cylinder - Cover	258
Tarp Transition	259
Lid Pneumatics	260
Decals	262

Interactive Features

NOTE:

This manual incorporates several interactive features to provide supplemental information and ease of navigation. The information below is to aid in the identification and use of these features.

Hyperlinks

Hyperlinks provide direct access to a specific destination when clicked. The entire Table of Contents of this manual is hyperlinked to provide quick access to all sections of this manual when viewing the electronic version.

Hyperlinks within the content are denoted by **blue, bold underlined text**. Electronic format viewers can click these links for direct access to New Leader online features. Internet access is required.

Insert Current New Leader Warranty

SAFETY

PLEASE ! ALWAYS THINK SAFETY FIRST !!

The purpose of this manual is to familiarize the person (or persons) using this unit with the information necessary to properly install, operate, and maintain this system. The safety instructions indicated by the safety alert symbol in the following pages supersede the general safety rules. These instructions cannot replace the following: the fundamental knowledge that must be possessed by the installer or operator, the knowledge of a qualified person, or the clear thinking necessary to install and operate this equipment. Since the life of any machine depends largely upon the care it is given, we require that this manual be read thoroughly and referred to frequently. If for any reason you do not understand the instructions, please call your authorized dealer or our Product Sales and Support Department at 1-888-363-8006.

It has been our experience that by following these installation instructions, and by observing the operation of the spreader, you will have sufficient understanding of the machine enabling you to troubleshoot and correct all normal problems that you may encounter. Again, we urge you to call your authorized dealer or our Product Sales and Support Department if you find the unit is not operating properly, or if you are having trouble with repairs, installation, or removal of this unit.

We urge you to protect your investment by using genuine NLM parts and our authorized dealers for all work other than routine care and adjustments.

New Leader Manufacturing reserves the right to make alterations or modifications to this equipment at any time. The manufacturer shall not be obligated to make such changes to machines already in the field.

This Safety Section should be read thoroughly and referred to frequently.

ACCIDENTS HURT !!!

ACCIDENTS COST !!!

ACCIDENTS CAN BE AVOIDED !!!

Important Safety Information

▲ WARNING

Before using this equipment, read, understand and follow all instructions in the Operator's Manual provided with this equipment. If the user and/or assistants cannot read or understand the warnings and instructions, the employer of the user and/or assistants must provide adequate and necessary training to ensure proper operation and compliance with all safety procedures pertaining to this equipment. If Operator's Manual has been lost, visit www.newleader.com or call your authorized dealer or our Product Sales & Support Department at (800) 363-1771 for replacements. Serious injury or death can result from the failure to read, understand, and follow instructions provided in this manual.

Figure 1.1 - The need for safety cannot be stressed strongly enough in this manual. At New Leader Manufacturing, we urge you to make safety your top priority when operating any equipment. We firmly advise that anyone allowed to operate this machine carefully read, learn and understand all messages and information in this manual and on machine's safety decals before operating machine, as well as familiarize themselves with the location and function of all machine controls.

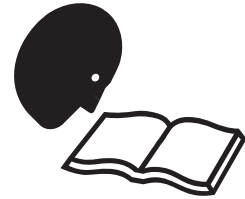

Figure 1.1

The following guidelines are intended to cover general usage and to assist you in avoiding accidents. There will be times when you will run into situations that are not covered in this section. At those times the best standard to use is common sense. If, at any time, you have a question concerning these guidelines, please call your authorized dealer or our Product Sales & Support Department at (800) 363-1771.

Safety Alert Symbols



Take note! This safety alert symbol found throughout this manual is used to call your attention to instructions involving your personal safety and that of others. Failure to follow these instructions can result in injury or death.

In this manual and on the safety signs placed on the unit, the words "DANGER," "WARNING," "CAUTION," and "NOTICE" are used to indicate the following:



DANGER indicates a hazardous situation which, if not avoided, will result in death or serious injury.



WARNING indicates a hazardous situation which, if not avoided, could result in death or serious injury.



CAUTION indicates a hazardous situation which, if not avoided, could result in minor or moderate injury.



NOTICE is used to address practices not related to physical injury.

NOTE:

Provides additional information to simplify a procedure or clarify a process.

General Safety Rules

Operations

PREPARE FOR EMERGENCIES

Figure 1.2 - Be prepared if a fire starts. Keep a fully charged fire extinguisher and first aid kit in accessible place on the vehicle at all times.

Fire extinguisher must be Type ABC or Type BC.

Keep emergency numbers for doctors, ambulance service, hospital and fire department available at all times.



Figure 1.2

INSPECT HARDWARE BEFORE USE

Figure 1.3 - Inspect all bolts, screws, fasteners, keys, chain drives, body mounts and other attachments periodically. Immediately replace any missing or damaged parts with NLM specified parts.

Inspect spinner fins, spinner frame mounting and spinner fin hardware daily. Look for missing or loose fasteners, wear and cracks. Replace immediately with NLM specified parts.

Tighten all bolts, nuts and screws to specified torques. Refer to "Standard Torques" in Maintenance section of this manual.

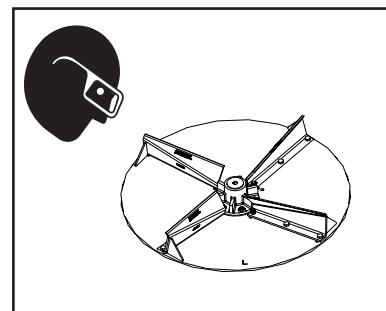

Figure 1.3

HANDLE FLAMMABLE MATERIALS SAFELY

Figure 1.4 - Handle fuel and hydraulic oil with care. They are highly flammable.

Exposure to toxic fluids or fumes may occur during the normal operation of this system. Before attempting to fill, use, or service this system, read Safety Data Sheets (SDS) to know the specific hazards of the fluids you are using. Always use proper Personal Protective Equipment when attempting to fill, use, or service this system.

Always stop engine before refueling machine or filling hydraulic reservoir.

Never smoke while adding fuel or oil to machine. Add fluids in a safe place away from open flame and sparks.

Do not allow overflow. Clean up spilled fuel and oil immediately.

Always have a multipurpose dry chemical fire extinguisher filled and available during machine operation and when adding fuel. Know how to use it.

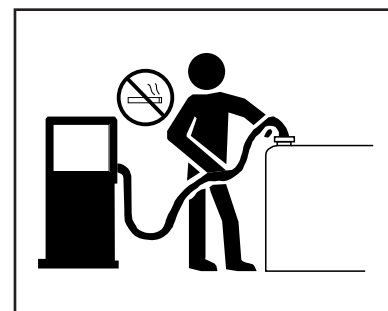

Figure 1.4

General Safety Rules

Operations

HANDLE HAZARDOUS MATERIALS SAFELY

Figure 1.5 - Materials to spread can be dangerous.

Improper selection, application, use or handling may be a hazard to persons, animals, plants, crops or other property.

A Safety Data Sheet (SDS) provides specific details on chemical products: physical and health hazards, safety procedures and emergency response techniques.

Check all SDS's before starting any job using a hazardous material. Follow all instructions and precautions given by the material manufacturer.



Figure 1.5

WORK IN WELL-VENTILATED AREAS

▲ WARNING	Never run machine engine inside a building unless adequate ventilation is provided to safely and properly remove exhaust fumes. Failure to comply with this requirement could result in death or serious injury.
------------------	--

Figure 1.6 - Always work in a properly ventilated area.

Engine exhaust fumes can cause sickness or death. If it is necessary to run an engine in an enclosed area, use proper equipment to safely remove exhaust fumes from the working area.

Open building doors and get fresh air into the working area whenever possible.



Figure 1.6

PROTECT AGAINST NOISE

Figure 1.7 - Long periods of exposure to high decibels or loud noise can cause hearing impairment or loss.

Wear proper hearing protection such as earmuffs or earplugs during periods of exposure to high decibels or loud noise.

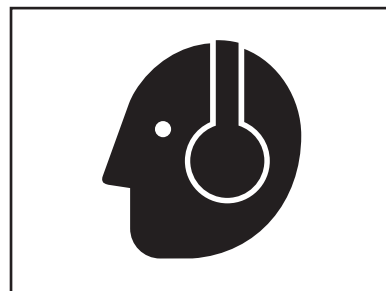

Figure 1.7

General Safety Rules

Operations

AVOID MOVING PART HAZARDS

Figure 1.8 - Entanglement in rotating drive lines or moving parts will cause serious injury or death.

Stay clear of all moving parts, such as shafts, couplings and universal joints.

Make sure all personnel are clear of machine before starting.



Figure 1.8

Figure 1.9 - Do not operate machine without all guards and shields closed and secured.

Disconnect and lock out power source before removing guards.

Disconnect and lock out power source before adjusting or servicing.

Keep hands, feet, hair and clothing away from moving parts.

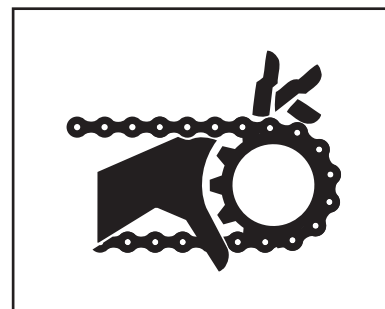

Figure 1.9

Figure 1.10 - Keep away from spinners while they are turning.

Rocks, scrap metal and other material can be thrown from the spinners violently. Stay away from discharge area.

Stop machine before servicing or adjusting. Wear eye protection.

Make sure discharge area is clear before spreading.

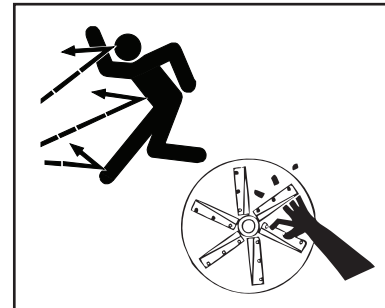

Figure 1.10

Figure 1.11 - Stay out of spreader.

If necessary to enter the spreader, return to shop, empty body, turn off all power, engage brakes, shut down engine and remove keys before entering.

Tag all controls to prohibit operation. Tags should be placed, and removed, by the person working in the body.

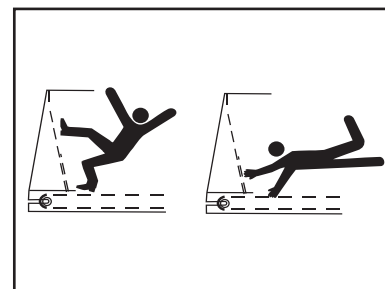

Figure 1.11

General Safety Rules

Operations

DO NOT CLIMB OR STAND ON MACHINE

Figure 1.12 - Never allow any personnel to ride in or on the machine.

Use inspection ladder or portable ladder to view the unit. Use caution when getting on and off the ladder, especially in wet, icy, snowy or muddy conditions. Clean mud, snow and ice from steps and footwear.

Always maintain three-point contact with steps, ladders and handholds. Face the machine when mounting and dismounting inspection ladder. Do not jump off machine.



Figure 1.12

OPERATE MACHINE SAFELY

Always walk around and visually inspect machine before using. Check the immediate vicinity of machine for people and obstructions. Ensure adequate visibility.

Avoid distractions such as reading, eating or operating personal electronics while operating machine. Never operate the machine under the influence of alcohol, drugs or while otherwise impaired.

Always come to a complete stop before reversing. Be sure that all personnel are clear of machine path. Turn around and look directly for best visibility. Ensure all rear view mirrors are properly installed and adjusted. Use a signal person when backing if view is obstructed or when in close quarters.

Always disengage hydraulics before shutting down engine. DO NOT start engine with hydraulics engaged.

General Safety Rules

Transportation & Handling

TRAVELING & TRANSPORTING ON PUBLIC ROADS

Always walk around and visually inspect the machine before traveling on public roads. Check for damage and/or faulty components that can fail and create a hazard or unsafe condition. Make sure all machine systems operate properly, including but not limited to: headlights, tail and brake lights, hazard warning lights, turn indicators, parking brake, horn and rear view mirrors. Repair or replace any component that is not in proper working order.

Never drive machine at a speed that causes it to bounce or cause loss of control.

Obey all traffic safety laws and regulations. Operate the machine with hazard warning lights on, unless prohibited by law. It is the operator's responsibility to activate and use road lights properly while traveling on public roads.

Cover all loads that may spill or blow away. Environmental damage may result. Do not spread dusty materials where dust may create pollution, visibility issues or interfere with traffic on public roads.

When transporting equipment or machine on a trailer, ensure it is properly secured. Be sure that SMV signs on equipment or machine are covered while in transport on a trailer.

Be aware of overhead structures and power lines. Make sure machine can safely pass under. Refer to "Dimensions & Capacities" pages in the Operations section of this manual.

NAVIGATING ROUGH & UNEVEN TERRAIN

Figure 2.1 - Turn slowly and be careful when traveling on rough surfaces and side slopes. Avoid holes, ditches and obstructions that may cause machine to roll over, especially with a loaded spreader.

Never drive near the edge of a gully or steep embankment.

Load may shift, causing vehicle to tip.

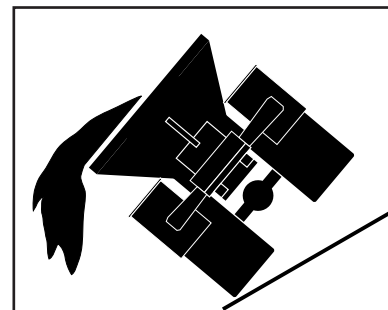

Figure 2.1

General Safety Rules

Maintenance

READ AND UNDERSTAND MAINTENANCE PROCEDURES

Figure 3.1 - Read the maintenance and safety instructions and understand them before performing any maintenance procedure.

Never perform any maintenance procedure or repair if the instructions and safety procedures are not fully understood. Only trained and qualified personnel should perform any maintenance procedure or repair.

Never modify any equipment or add attachments not approved by New Leader Manufacturing.

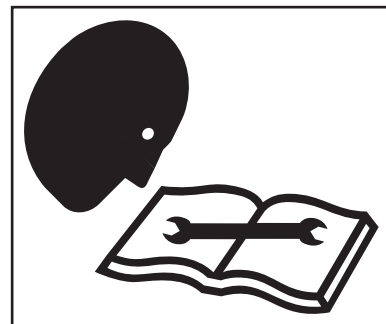

Figure 3.1

DO NOT SERVICE OR ADJUST MACHINE WHILE IN MOTION

Figure 3.2 - Never lubricate, service or adjust the machine or any of its components while they are moving.

Never wear loose clothing or jewelry when working near machine tools or moving parts.

Remove rings and other jewelry to prevent electrical shorts and other personal injury when in contact with machine tools or moving parts.

Close and secure all guards removed for service. Check all screws, bolts, nuts and fasteners for proper torques before operating machine.

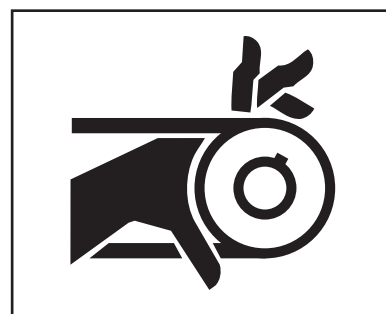

Figure 3.2

WEAR PROPER PROTECTIVE EQUIPMENT

Figure 3.3 - Wear close-fitting clothing and proper safety equipment for the job.

Always wear eye protection when working on or around the machine.

Wear a suitable hearing protection device such as earmuffs or earplugs to protect against high decibels or loud noises.

Prolonged exposure to high decibels or loud noise can cause hearing impairment or loss of hearing.

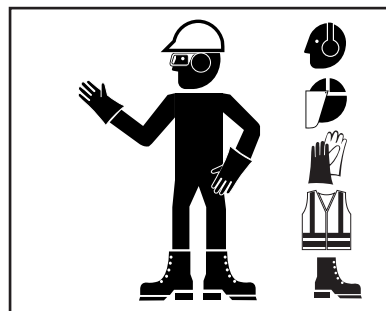

Figure 3.3

Wear protective gloves to protect hands from cuts, abrasions and minor burns.

General Safety Rules

Maintenance

HANDLE FLAMMABLE SOLVENTS SAFELY

Figure 3.4 - Never use diesel fuel, kerosene, gasoline or any flammable solvents for cleaning.

Exposure to toxic fluids or fumes may occur during the normal operation of this system. Before attempting to fill, use, or service this system, read Safety Data Sheets (SDS) to know the specific hazards of the fluids you are using. Always use proper Personal Protective Equipment when attempting to fill, use, or service this system.

Perform work using flammable fluids and solvents in a safe place away from open flame and sparks. Do not smoke.

Do not weld, grind or flame cut on any tank containing oil, fuel, fumes or any other flammable material, or any container that contents or previous contents are unknown. Move all flammable materials and containers away from work area.

Clean up spilled fuel and oil immediately.

Always have a multipurpose dry chemical fire extinguisher filled and available. Know how to use it.

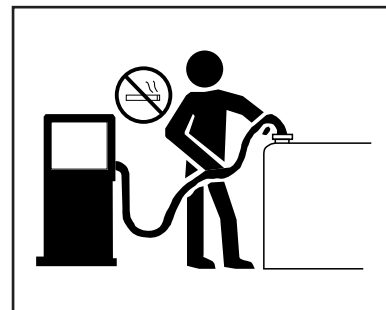

Figure 3.4

USE PROPER LIFTING EQUIPMENT

Figure 3.5 - Use only lifting devices that meet or exceed OSHA standard 1910.184 or ASME B30.20-2013.

Never lift equipment over people.

Never lift a loaded unit. Never lift unit with any loose objects or persons in the body. Loads may shift or fall if improperly supported, causing death, serious injury or machine damage.

Before unfastening heavy parts or assemblies, support with adequate hoist or other device to prevent falling, tipping, swinging or any other movement that may cause injury or damage.



Figure 3.5

USE PROPER TOOLS FOR THE JOB

Figure 3.6 - Use of improper tools (such as a screwdriver instead of a pry bar, pliers instead of a wrench, a wrench instead of a hammer) can cause serious injuries or machine damage.

Use power tools only to loosen threaded parts and fasteners. Using power tools to tighten may cause over-tightening and component damage.

Use only service parts meeting New Leader specifications.

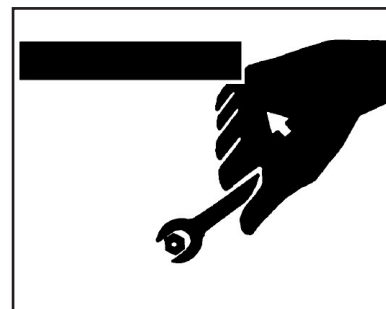

Figure 3.6

General Safety Rules

Maintenance

HIGH PRESSURE FLUID HAZARDS

Figure 3.7 - Escaping fluid under pressure can penetrate the skin causing serious injury.

Always stop machine, allow to cool and relieve pressure before servicing hydraulic system. Never open hydraulic lines under pressure. Make sure all connections are tight and all hoses are in good condition before pressurizing system.

Always use a piece of cardboard or wood to search for leaks instead of hand. Wear impervious gloves and eye protection when servicing system.

Seek medical attention immediately if fluid penetrates your skin. Gangrene may result if wound is left untreated.



Figure 3.7

AVOID HEATING NEAR HIGH PRESSURE FLUID LINES

Figure 3.8 - Flammable spray can be generated by heating near pressurized fluid lines, resulting in burns to yourself and bystanders.

Do not heat by welding, soldering or using a torch near pressurized fluid lines or other flammable materials.

Pressure lines can suddenly burst when heat goes beyond the immediate flame area.

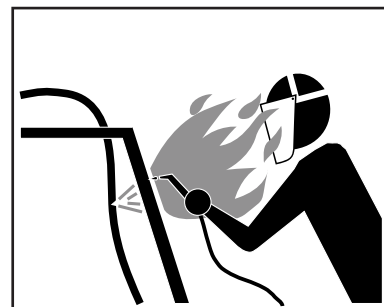

Figure 3.8

AVOID TOXIC FUMES & DUST

Figure 3.9 - Hazardous fumes can be generated when paint is heated from welding, soldering or using a torch.

Remove paint before heating:

- Remove a minimum of 4 in (100 mm) from area to be affected by heating. If paint cannot be removed, wear an approved respirator while heating or welding.
- Avoid breathing dust from sanding or grinding on paint.
- If a solvent or paint stripper is used, wash stripper away with soap and water before heating or welding. Remove solvent or paint stripper containers and other flammable material from area. Allow fumes to disperse for at least 15 minutes before heating or welding.

Do not use chlorinated solvents in areas where welding will take place.

Perform all work in a well-ventilated area that will carry all toxic fumes and dust away.



Figure 3.9

General Safety Rules

Maintenance

CLEAN MACHINE OF HAZARDOUS CHEMICALS

CAUTION

During application of hazardous chemicals, residue can build up on the inside or outside of the vehicle. Clean vehicle according to use instructions of hazardous chemical. Failure to comply with this requirement may result in minor or moderate injury.

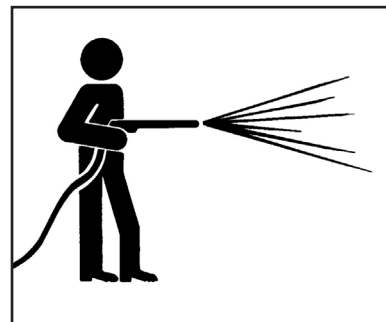

Figure 3.10

Figure 3.10 - When exposed to hazardous chemicals, clean exterior and interior of vehicle daily to keep free of the accumulation of visible dirt and contamination.

1. Clean operator's station to maintain unobstructed visibility of all windows and mirrors, and safe operation of all controls.

NOTICE

Directing pressurized water at electronic/ electrical components, bearings and hydraulic seals or other sensitive parts and components may cause product malfunctions. Reduce pressure and spray at 45 to 90 degree angles.

2. Wash entire exterior of vehicle.
3. Dispose of any wash water with hazardous concentrations of active or non-active ingredients according to published regulations or directives.

HANDLE BATTERIES SAFELY

WARNING

Sulfuric acid in battery electrolyte is poisonous. It can burn skin, eat holes in clothing, and cause blindness if it contacts eyes. Keep sparks and flame away from batteries. Wear proper safety equipment. Failure to comply with this requirement could result in death or serious injury.

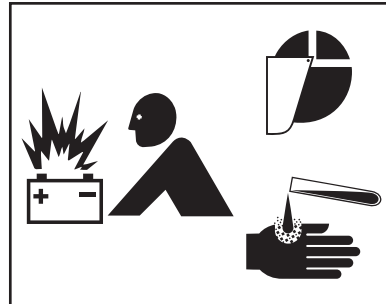

Figure 3.11

Figure 3.11 - Lead acid batteries generate flammable and explosive gases. Keep sparks and flame away from batteries. Do not smoke.

If acid contacts eyes, skin or clothing, flush with water immediately. Seek immediate medical attention if acid contacts eyes.

PROPER TIRE MAINTENANCE

Figure 3.12 - Never weld on a wheel or rim that has a tire on it.

Never attempt to mount or remove a tire unless using the proper equipment, tire safety cage, instructions, training, and you are qualified to perform the work safely. Failure to follow the correct procedures when mounting a tire on a wheel or rim can cause an explosion and serious injury.

Tire service procedures must be performed by trained and qualified personnel.



Figure 3.12

General Safety Rules

Storage

PARK VEHICLE SAFELY

Figure 4.1 - When leaving the vehicle unattended for any reason, be sure to:

- Shut down PTO.
- Shut off vehicle's engine, and unit's engine if applicable.
- Place vehicle transmission in "Neutral" or "Park".
- Set parking brake firmly.
- Remove ignition key and take it with you.
- Block wheels.

These actions are recommended to avoid unauthorized use, runaway, vandalism, theft and unexpected operation during startup.

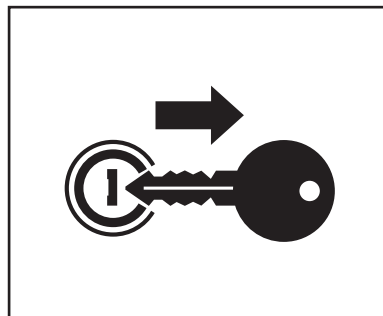

Figure 4.1

SUPPORT MACHINE PROPERLY

Figure 4.2 - When machine is removed from vehicle, always store on adequate supports on a firm level surface. Improper supporting or storage of spreader may cause machine to fall, resulting in serious injury or death.

Never use lifting device to free machine from a chassis, storage stands or frozen ground, or to lift the chassis in any way. Shock loading is prohibited and sudden accelerations must be avoided. Lifting in such a manner could result in injury or machine damage.



Figure 4.2

DISPOSE OF WASTE PROPERLY

Figure 4.3 - Improper disposal of waste can threaten the environment and ecology. Potentially harmful waste used with equipment include items such as fuel, oil, filters and batteries.

Use leakproof containers when draining fluids. Do not use food or beverage containers that may mislead someone into drinking from them. Do not pour waste onto the ground, down a drain, or into any water source.

Comply with all OSHA, local, City, State, Province, Country and jurisdiction regulations, ordinances and standards, related to your particular work area and environment. Inquire on proper disposal methods from your local environmental or recycling center, or from your local dealer.

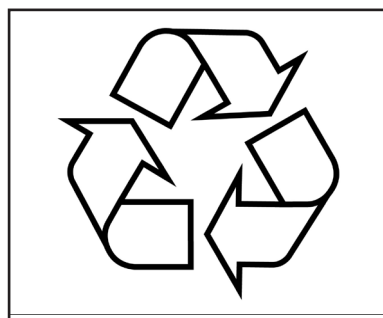

Figure 4.3

Safety Decal Maintenance

Keep safety decals and signs clean and legible at all times.

Replace safety decals and signs that are missing or have become illegible.

Replaced parts that displayed a safety sign should also display the current sign.

Safety decals or signs are available from your dealer's Parts Department or from New Leader Manufacturing by calling (800) 363-1771.

Safety Decal Installation

Clean Surface

Wash the installation surface with a synthetic, free-rinsing detergent. Avoid washing the surface with a soap containing creams or lotion. Allow to dry.

Position Safety Decal

Decide on the exact position before application. Application marks may be made on the top or side edge of the substrate with a lead pencil, marking pen, or small pieces of masking tape. NOTE: Do not use chalk line, china marker, or grease pencil. Safety decals will not adhere to these.

Remove the Liner

A small bend at the corner or edge will cause the liner to separate from the decal. Pull the liner away in a continuous motion at a 180-degree angle. If the liner is scored, bend at score and remove.

Apply Safety Decal

Tack decal in place with thumb pressure in upper corners. Using firm initial squeegee pressure, begin at the center of the decal and work outward in all directions with overlapping strokes. NOTE: Keep squeegee blade even—nicked edges will leave application bubbles. Pull up tack points before squeegeeing over them to avoid wrinkles.

Remove Pre-mask

If safety decal has a pre-mask cover remove it at this time by pulling it away from the decal at a 180 degree angle. NOTE: It is important that the pre-mask covering is removed before the decal is exposed to sunlight to avoid the pre-mask from permanently adhering to the decal.

Remove Air Pockets

Inspect the decal in the flat areas for bubbles. To eliminate the bubbles, puncture the decal at one end of the bubble with a pin (never a razor blade) and press out entrapped air with thumb moving toward the puncture.

Re-Squeegee All Edges

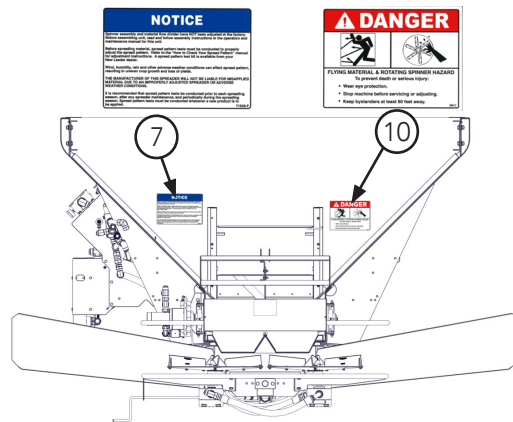
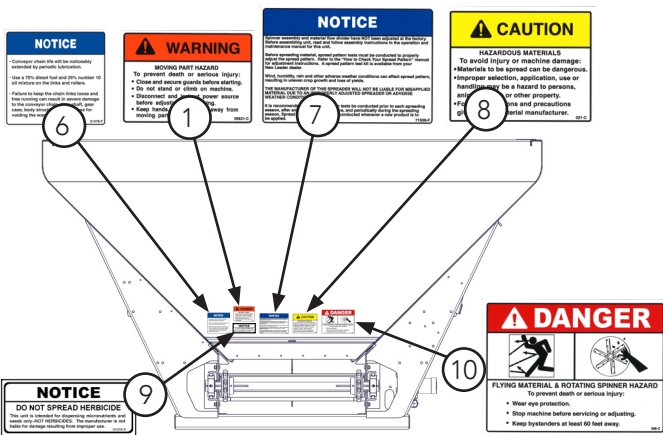
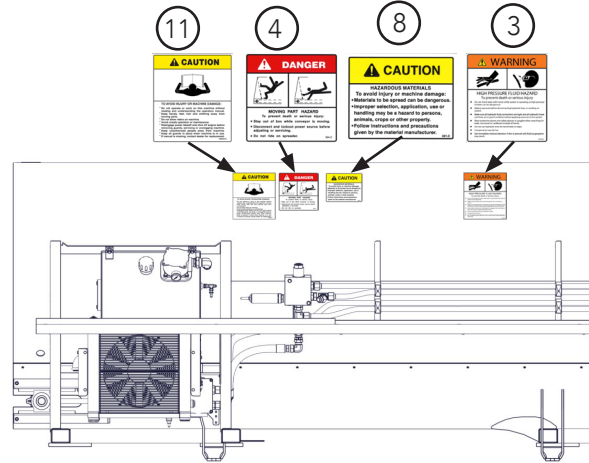
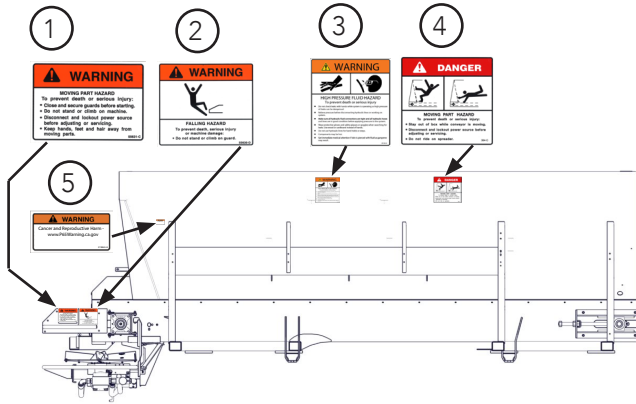

1. WARNING: MOVING PART HAZARD**To prevent death or serious injury:**

- Close and secure guards before operating machine.
- Do not stand or climb on machine.
- Disconnect and lockout power source before adjusting or servicing.
- Keep hands, feet and hair away from moving parts.

2. WARNING: FALLING HAZARD**To prevent death, serious injury or machine damage:**

- Do not climb or stand on guard.

3. WARNING: HIGH-PRESSURE FLUIDS**To prevent death or serious injury:**

- Do not check for leaks with hands while system is operating as high pressure oil leaks can be dangerous!
- Relieve system pressure before disconnecting hydraulic lines or working on system.
- Make sure all hydraulic fluid connections are tight and all hydraulic hoses and lines are in good condition before applying pressure to the system.
- Wear protective gloves and safety glasses or goggles when searching for leaks. Use wood or cardboard instead of hands.
- Do not use hydraulic lines for hand holds or steps.
- Components may be hot.
- Get immediate medical attention if skin is pierced with fluid as gangrene may result.

4. DANGER: MOVING PART HAZARD**To prevent death or serious injury:**

- Stay out of box while conveyor is moving.
- Disconnect and lock out power source before adjusting or servicing.
- Do not ride on the spreader.

5. WARNING: HAZARDOUS MATERIALS**To avoid injury:**

- Cancer and Reproductive Harm - www.P65Warning.ca.gov

6. NOTICE: CONVEYOR CHAIN LUBRICATION**To avoid machine damage and premature wear:**

- Conveyor chain life will be noticeably extended by periodic lubrication.
- See "Lubricant & Hydraulic Oil Specifications" in this manual for details.
- Failure to keep the chain links loose and free running can result in severe damage to the conveyor chain, drag shaft, gearcase and body structure, and is cause for voiding the warranty.

7. NOTICE: SPREAD PATTERN TESTING**To obtain optimal machine performance:**

- Spinner assembly and material flow divider have NOT been adjusted at the factory. Before assembling unit, read and follow assembly instructions in the operation and maintenance manual for this unit.
-
- Before spreading material, spread pattern tests must be conducted to properly adjust the spread pattern. Refer to the "How to Check your Spread Pattern" manual for adjustment instructions. A spread pattern test kit is available from your New Leader dealer.
-
- Wind, humidity, rain and other adverse weather conditions can affect spread pattern, resulting in uneven crop growth and loss of yields.
-
- THE MANUFACTURER OF THIS SPREADER WILL NOT BE LIABLE FOR MISAPPLIED MATERIAL DUE TO AN IMPROPERLY ADJUSTED SPREADER OR ADVERSE WEATHER CONDITIONS.
-
- It is recommended that spread pattern tests be conducted prior to each spreading season, after any spreader maintenance, and periodically during the spreading season. Spread pattern tests must be conducted whenever a new product is to be applied.

8. CAUTION: HAZARDOUS MATERIALS**To avoid injury or machine damage:**

- Materials to be spread can be dangerous.
- Improper selection, application, use or handling may be hazardous to persons, animals, crops or other property.
- Follow instructions and precautions given by material manufacturer.

9. NOTICE: DO NOT SPREAD HERBICIDE**To avoid machine damage and premature wear:**

- This unit is intended for dispensing micronutrients and seeds only--NOT HERBICIDES. The manufacturer is not liable for damage resulting from improper use.

10. DANGER: FLYING MATERIAL AND ROTATING SPINNER HAZARD**To prevent death or serious injury:**

- Wear eye protection.
- Stop machine before servicing or adjusting.
- Keep bystanders at least 60 feet away.

11. CAUTION: TO AVOID INJURY OR MACHINE DAMAGE:

- Do not operate or work on this machine without reading and understanding the operator's manual.
- Keep hands, feet, hair and clothing away from moving parts.
- Do not allow riders on machine.
- Avoid unsafe operation or maintenance.
- Disengage power takeoff and shut off engine before removing guards, servicing or unclogging machine.
- Keep unauthorized people away from machine.
- Keep all guards in place when machine is in use.
- If operator's manual is missing, contact your local New Leader dealer or print a new copy from www.highwayequipment.com.

This page is intentionally left blank.

INSTALLATION

INSTALLATION

Recommended sequence of installation is:

1. Mounting of PTO and pump.
2. Installation of radar (if applicable)
3. Mounting of spreader.
4. Installation of controller.
5. Installation of chassis hydraulic hose and electrical wiring to spreader.
6. Installation of optional parts.
7. Filling of hydraulic reservoir and lubrication.
8. Checking for leaks and proper functioning.

NOTICE

Pump and truck requirements must be determined prior to installation of the spreader.

Hydraulic Requirements

Hydraulics		GPM (LPM) (Gallons/Liters per Minute)	Maximum Pressure (PSI)
L4000G4	Spinner & Conveyor	40 (151.4)	3100
	MultApplier	9 (34.1)	1500
L4000G4 HP	Spinner	40 (151.4)	3100
	Conveyor	20 (75.7)	3400
	MultApplier	20 (75.7)	1500

HECO Pump Part Numbers	Pump CID	Theoretical Pump GPM (LPM) 100% Efficiency	Pump RPM
86665	4.38	40 (151.4)	2100
304424 (Front Tandem Section)	4.46	40 (151.4)	2075
304425 (Rear Section for Insert)	0.93	9 (34.1)	
304426 (Rear Section for HP Hydraulics)	2.17	20 (75.7)	

*Requires higher RPM to achieve GPM

Truck Requirements

Before mounting the spreader on a truck, the following major questions must be considered:

1. Is the CA (Cab to Axle) dimension of the truck correct for the length of the spreader?
2. The Dimensions and Capacities chart in the operator's manual will assist in matching spreader to truck.
3. Is the truck's GAWR (Gross Axle Weight Rating) and the GVWR (Gross Vehicle Weight Rating) adequate to carry the fully loaded spreader?
4. Refer to your New Leader dealer to find the GAWR and GVWR for most trucks, and how to calculate the weight distribution on each axle and total loaded vehicle weight.

Truck Frame Length

Refer to “Dimensions & Capacities” section in the operator’s manual for approximate length from the rear of the cab to the rear end of the frame. Shorten truck frame as necessary, making sure to follow truck manufacturer’s specifications so as not to void truck warranty.

NOTICE

Do not weld to truck frame; it may void truck warranty.

A level top surface is necessary for mounting. Add steel shim bars or strips the same thickness as fish plates or other obstructions and as wide as the truck frame channel top flange. Shims must be drilled to

Lifting the Spreader

WARNING

Use only lifting devices that meet or exceed OSHA standard 1910.184 or ASME B30.20-2006. Never lift equipment over people. Never lift unit with anything or anybody in the body. Loads may shift or fall if improperly supported. Failure to comply with this requirement could result in death or serious injury.

CAUTION

Do not use lifting device to free unit from a chassis, storage stands or frozen ground, or to lift the chassis in any way. Shock loading is prohibited and sudden accelerations should be avoided. Failure to follow this requirement may result in injury or machine damage.

Always inspect unit lift points for signs of wear, cracking, corrosion, gouges, alterations, or distortion.

Always use a sling, spreader bar, or lifting bar that attaches to the lifting points with a minimum of 60 degrees from horizontal. It is preferable to use an “H” style lifting bar that keeps the attaching chains in a near vertical orientation as shown in Figure 1. Operators of lifting devices must be qualified and knowledgeable in their use and application.

Position the chassis with adequate room around the unit. Work in an environment that permits clear communication to others nearby. Keep area clear of persons when loads are to be lifted and suspended. Do not allow the lifted load to come in contact with any obstruction.

Store units on a solid surface using appropriate storage stands when not installed.

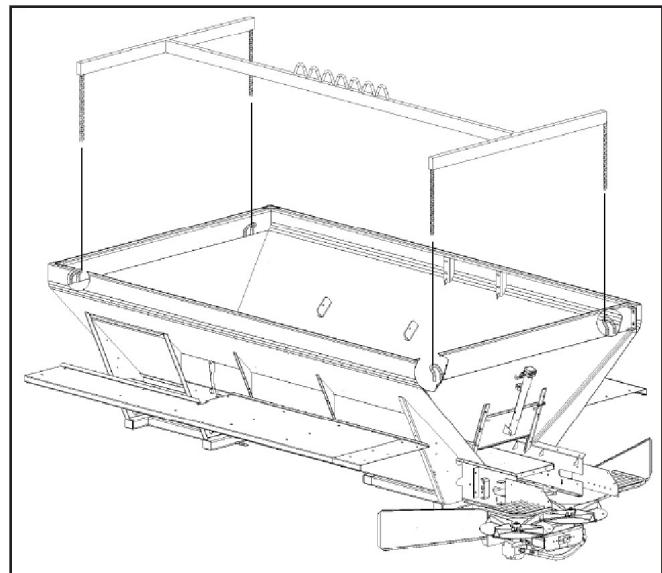

Figure 1 - Lifting Bar

Installing Body**⚠ CAUTION**

Be careful when drilling so as to not damage truck frame, fuel tank, or any other important components.

NOTICE

DO NOT WELD ON VEHICLE FRAME! Such welding can lead to fatigue cracking and must be avoided.

NOTICE

DO NOT PUT HOLES INTO TOP OR BOTTOM FLANGES—to do so may void truck manufacturer's warranty. When drilling holes in frame member, drill only through vertical web portions.

NOTICE

Connect welders ground directly to one of the items being welded anytime an arc welder is used on the vehicle or anything connected to the vehicle. Refer to Manufacturer's instructions.

IMPORTANT!

Disconnect electrical components from electrical system when welding on equipment to prevent component damage due to power surges or excessive current.

Front Mount Angles

Assemble two front mounting angle springs and hardware. Use a 3/8" (10mm) shim between cross tube mounting plate and truck frame mounting angle. Position assembly under second cross tube from front and against truck frame, make sure springs do not contact cross tube. Mark position of mounting angle holes on truck frame. Drill 9/16" (14mm) holes where marked and install mounting assembly using 1/2" hardware supplied. Weld mounting plate to bottom of cross tube on three sides, and remove 3/8" (10mm) shim (Figure 2). Tighten spring assembly until spring compressed height is 4" (102cm). There should be a 3/8" (10mm) space between cross tube mounting plate and truck frame mounting angle (Figure 2). Repeat this procedure on other side of truck frame, on same cross tube.

NOTE: It may be necessary to mount front mounting angle springs on first cross tube on some vehicles due to obstructions such as spring shackles, etc.

Center Mount Plates

Position center mounting plates at second cross tube from rear with slotted faces against truck frame and mark location of slots on truck frame. Drill 9/16" (14mm) diameter holes through truck frame, approximately (19mm) from bottom of slots (Figure 2). Weld mounting angle to bottom of cross tube on 3 sides (Figure 4). Install hardware and tighten to recommended torque.

Rear Mount Angles

Position rear mounting angles with the slotted faces against the side of the truck frame and centered on rear cross sill. Mark slot locations on truck frame. Drill 9/16" (14mm) diameter holes through truck frame at bottom end of slots (Figure 3). Weld mounting angle to bottom of cross tube on three sides (Figure 4). Install hardware and tighten to recommended torque.

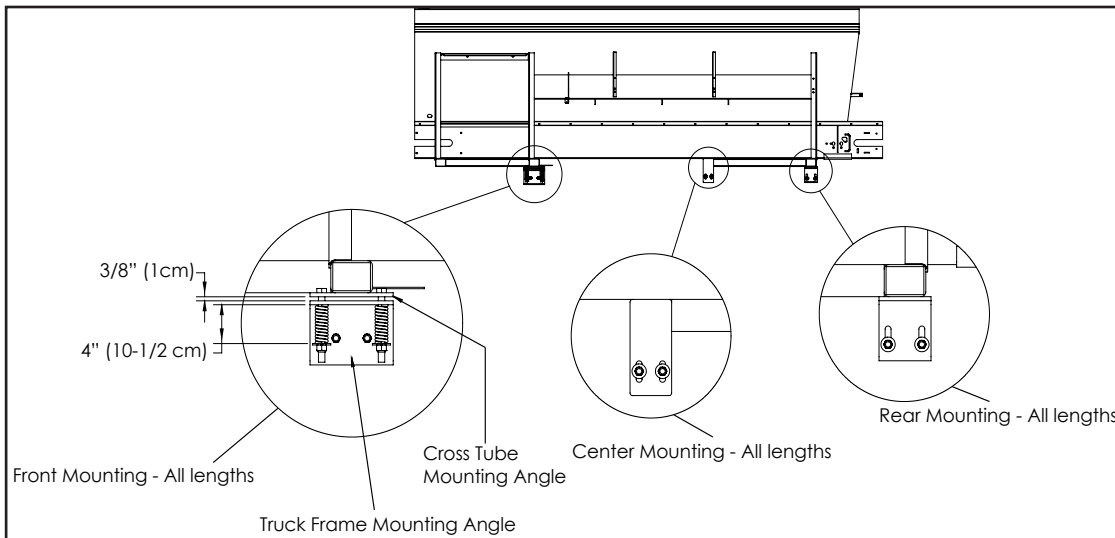

Figure 2 - Mounting Angle Installation - NL4500G4 Edge

Securing to Frame

Install mounting angles and tighten mounting bolts to recommended torque. Weld mounting angles to spreader cross tubes by welding on front, outer and rear sides (Figure 3). Make sure welds between mounting angles and spreader cross tubes are sound full fillet welds. Center mounting angles on tubes (as shown in Figure 3) so full fillet welds can be made on three sides. An edge bead weld is not a satisfactory weld for this service. Use E70S rod/wire for carbon steel to carbon steel and 309 rod/wire for carbon steel to stainless steel. Use 309 rod/wire to weld stainless steel to stainless steel.

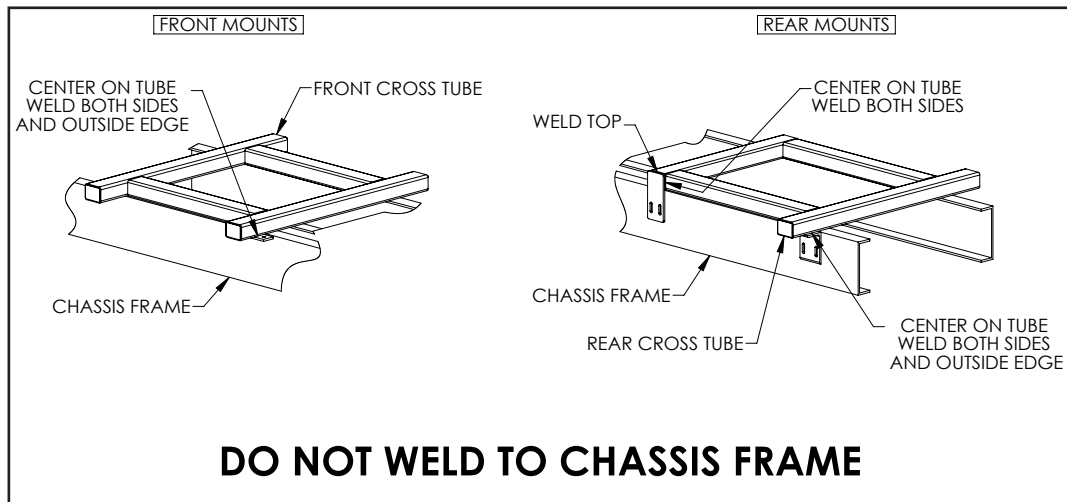
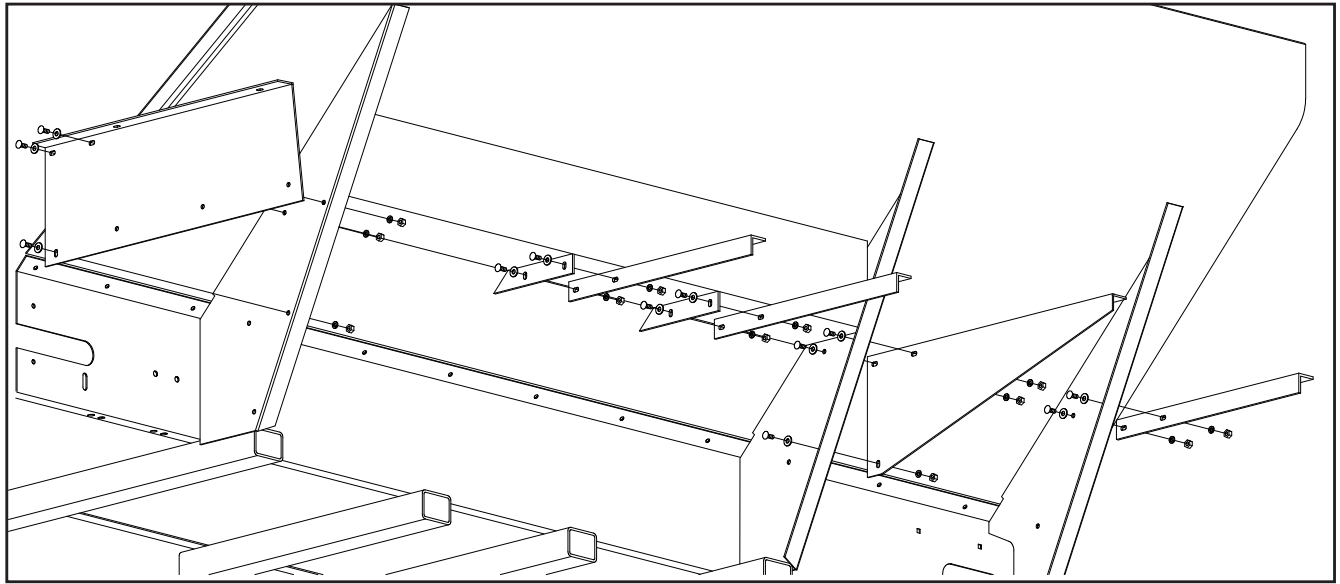
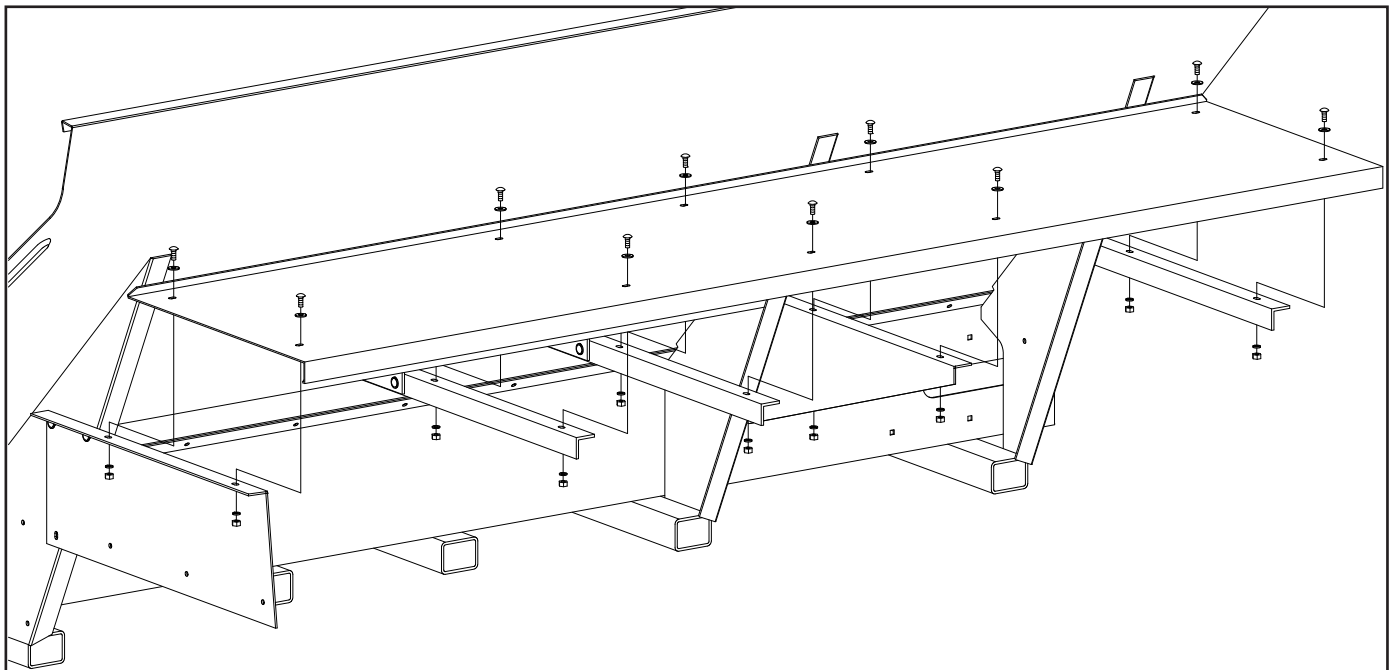

Figure 3 - Welding Instructions

Fender Installation



*Figure 4 - Fender Angle Installation



*Figure 5 - Fender Installation

* - Fenders may not be as shown

Attach fender angles and panels on spreader body stakes as shown in Figure 4. Do not tighten hardware at this time.

Attach fenders on top of angles/panels as shown in Figure 5. Tighten all hardware.

This page is intentionally left blank.

Hydraulic Hose Installation

CAUTION

Do not overtighten a threaded connection, the fitting or housing into which the fitting is placed could be distorted and an unstoppable leak could occur. Failure to follow this requirement may result in injury or machine damage.

WARNING

Do not use one manufacturer's hose with another manufacturer's fittings! Such will void any warranty and may cause premature burst or leak of hydraulic fluids! Failure to comply with this requirement could result in death or serious injury.

Determine pressure port of pump. Install pressure hose into this port as shown in Figure 6. Connect suction hose to opposite port and to tank outlet on hydraulic tank. Use plastic tie straps as necessary to

Hydraulic Pump Installation

HECO pumps are direct mount. See "Pump Hydraulics" in the spreader parts manual for assembly instructions.

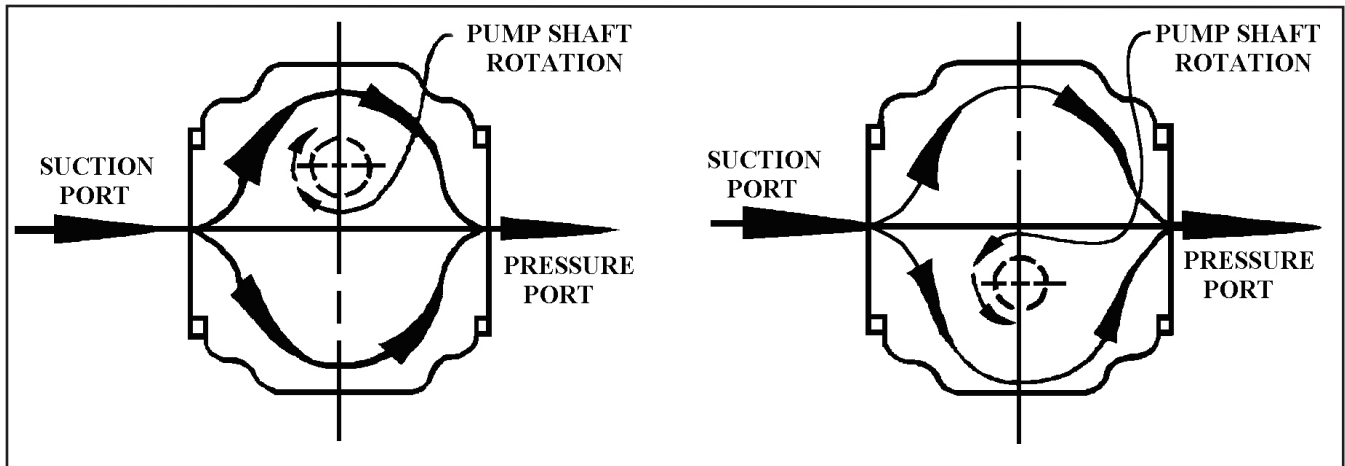

Figure 6 - Hydraulic Pump Installation

Use thread sealer on all NPT fittings. When using thread sealer, do not put it on the first three threads of the fitting. Too much on the fitting or on the first three threads will force it into the oil stream where it could damage the system.

Assemble system as shown in "Hydraulics" parts list in the parts manual. Place hose clamps as needed to keep hoses away from hot or moving parts. Do not let hoses hang so low as to be snagged. Do not stretch hoses tight.

Hydraulic hoses are as follows:

- Pressure Line: High pressure hose supplied by dealer. Hose must have minimum pressure rating that corresponds to the maximum pressure setting of the hydraulic system. Refer to "Hydraulic Requirements" on page 27.
- Suction Line: Suction hose supplied by dealer. Hose must meet or exceed SAE 100R4 requirements.

Hydraulic Hose Installation Guide

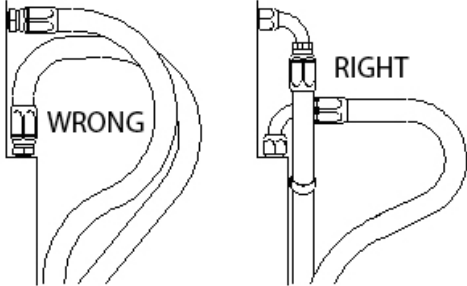
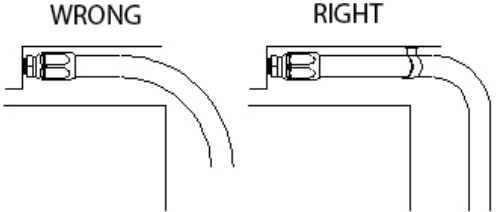
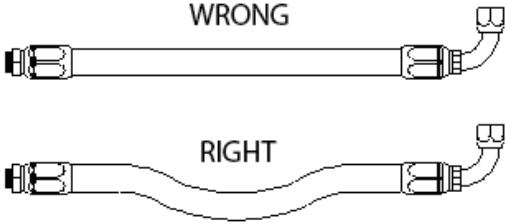
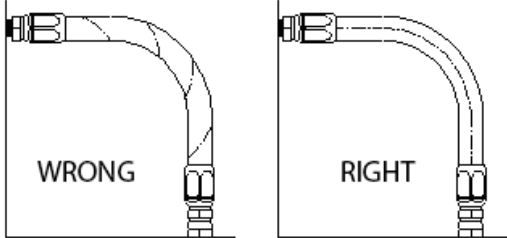
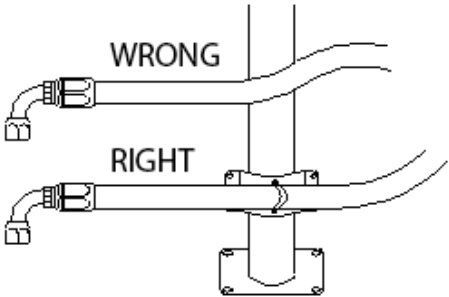
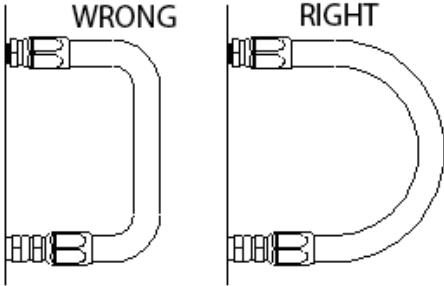
	
<p>1. Use elbows and adapters in the installation to relieve strain on the assembly, and to provide easier and neater installations that are accessible for inspection and maintenance. Remember that metal end fittings cannot be considered as part of the flexible portion of the assembly.</p>	<p>2. Install hose runs to avoid rubbing or abrasion. Clamps are often needed to support long runs of hose or to keep hose away from moving parts. It is important that the clamps be of the correct size. A clamp that is too large will allow the hose to move in the clamp causing abrasion at this point.</p>
	
<p>3. In straight hose installations allow enough slack in the hose line to provide for changes in length that will occur when pressure is applied. This change in length can be from +2% to -4%.</p>	<p>4. Do not twist hose during installation. This can be determined by the printed layline on the hose. Pressure applied to a twisted hose can cause hose failure or loosening of the connections.</p>
	
<p>5. Keep hose away from hot parts. High ambient temperature will shorten hose life. If you cannot route it away from the heat source, insulate it.</p>	<p>6. Keep the bend radii of the hose as large as possible to avoid hose collapsing and restriction of flow. Follow catalog specs on minimum bend radii.</p>

(Used with the permission of The Weatherhead Company.)

Hydraulic Drain Lines

See "Hydraulic Reservoir" and "Pump Hydraulics" in the parts manual for illustrations.

Filling Hydraulic System

NOTICE DO NOT attempt to run pump without first filling hydraulic reservoir and opening suction line valve, or damage to pump may occur.

Fill reservoir with hydraulic oil as specified in the "Lubrication and Maintenance" section in the operator's manual. Be sure oil is clean, free from dirt, water and other contaminants.

Lubricate all points necessary per Lubrication Chart in "Lubrication and Maintenance" section of operator's manual.

Electrical Connections

Connect all electrical control circuits. All wiring should be approved automotive insulated wire, supported adequately with insulating ties or straps, and located where it will not interfere with any control or access. Make sure wiring does not contact any moving parts or sharp edge and is kept away from any hydraulic line or any heated part.

Light Installation



All holes in truck cab walls, floor and firewall are to be grommeted, plugged and sealed to prevent entrance of engine fumes, dust, dirt, water and noise. Failure to comply with this requirement could result in death or serious injury.

Light installation must comply with all applicable requirements prescribed by FMVSS/CMVSS 108, ASABE S279, state and local regulations. See "Lights" parts page in the operator's manual for illustrations if applicable.

_Recommended sequence of installation is:

1. Spreader preparation.
2. Insert preparation.
3. Mounting of insert.
4. Connecting hydraulic hoses.
5. Installation of hillside divider and conveyor cover.
6. Checking installation.
7. Checking for leaks and proper functioning.

Hydraulic Requirements

Refer to "Hydraulic Requirements" on page 27 for hydraulic pump part numbers and specifications required for insert installation.

Recommended sequence of installation is:

1. Spreader preparation.
2. Insert preparation.
3. Mounting of insert.
4. Connecting hydraulic hoses.
5. Installation of hillside divider and conveyor cover.
6. Checking installation.
7. Checking for leaks and proper functioning.

Spreader Preparation

⚠ WARNING

Use only lifting devices that meet or exceed OSHA standard 1910.184. Never exceed work load limits or lift equipment over people. Empty spreader before lifting. Loads may shift or fall if improperly supported. Failure to comply with this requirement could result in death or serious injury.

1. Figure 1A - Remove Hardware (1) and Inverted "V" (2).
2. Remove Hardware (3) and Hillside Divider (4).
3. Replace chain shield hardware (3) from Hillside Divider and torque to specification.
4. Remove Hardware (5) and Side Boards (6) from the spreader, if so equipped, and set hardware aside. Replace chain shield hardware (3) from Hillside Divider and torque to specification.

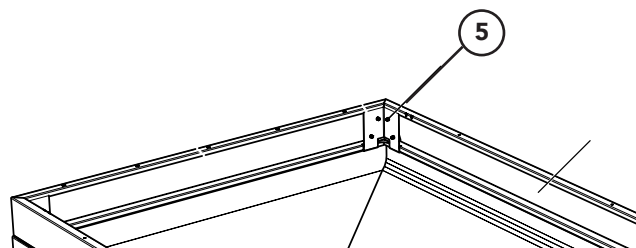
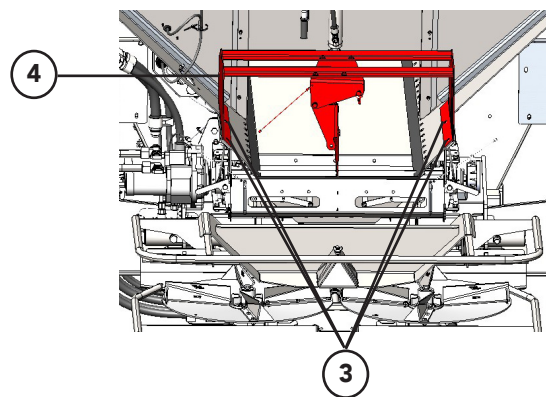
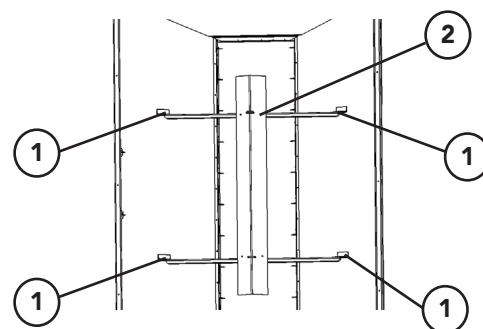

Figure 1

Insert Installation

5. Figure 2 - Remove the Grease Lines (7) from Bracket (8).
6. Figure 3 - Support endgate by attaching a hoist to the lift hooks. Remove hardware (9) from both sides of the endgate and carefully remove from the spreader.

NOTE: Always use a sling, spreader bar, or lifting bar that attaches to the lifting points with a minimum of 60 degrees from horizontal. It is preferable to use a straight style lifting bar that keeps the attaching chains in a near vertical orientation.

NOTE: Always inspect unit lift hooks for signs of wear, cracking, corrosion, gouges, alterations, or distortion before use.

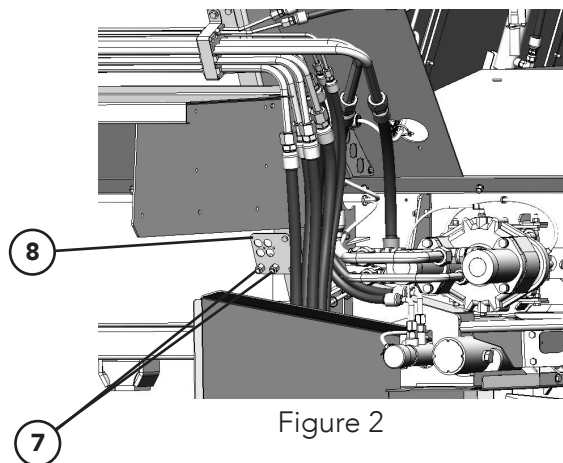

Figure 2

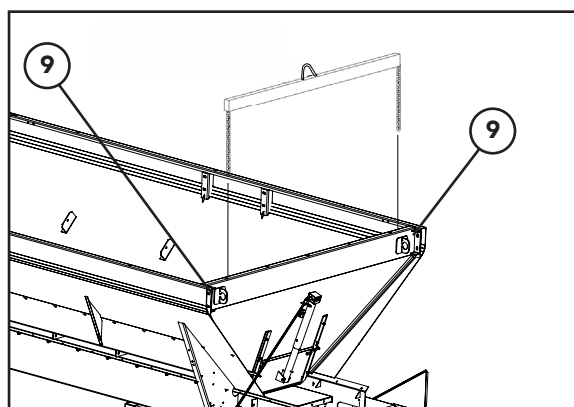
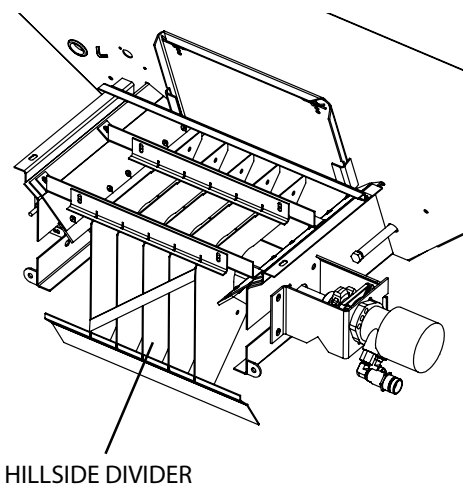
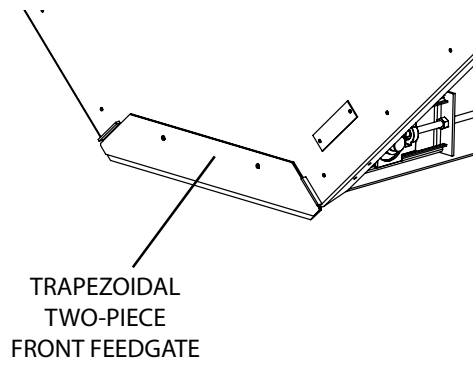
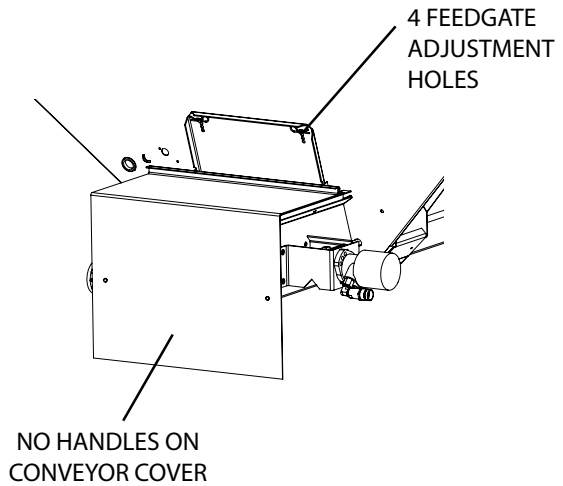

Figure 3

NOTICE The MULTAPPLIER is available in two different styles; Style I and Style II. The Style II MULTAPPLIER provides higher output capabilities. Refer to next page to determine your style of MULTAPPLIER insert.

Style I



Style II

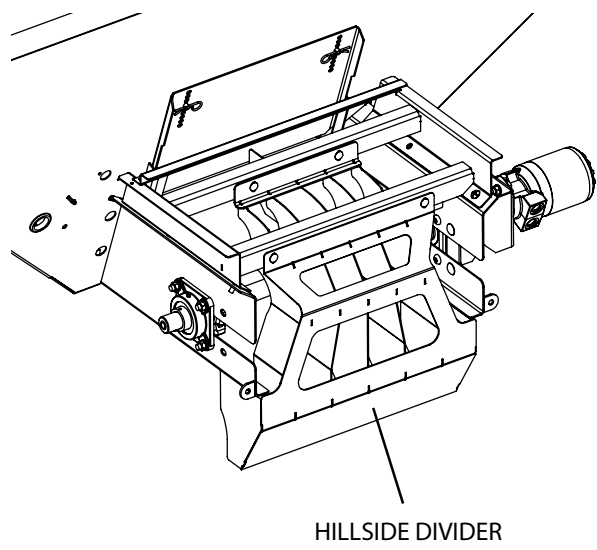
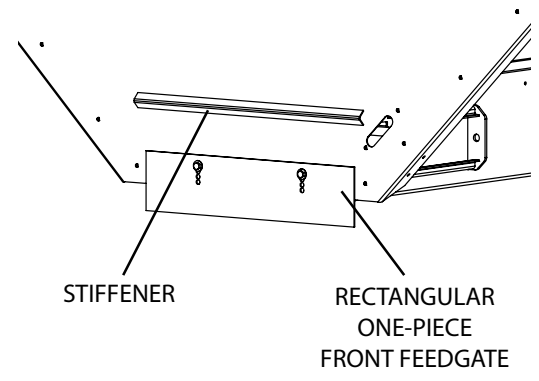
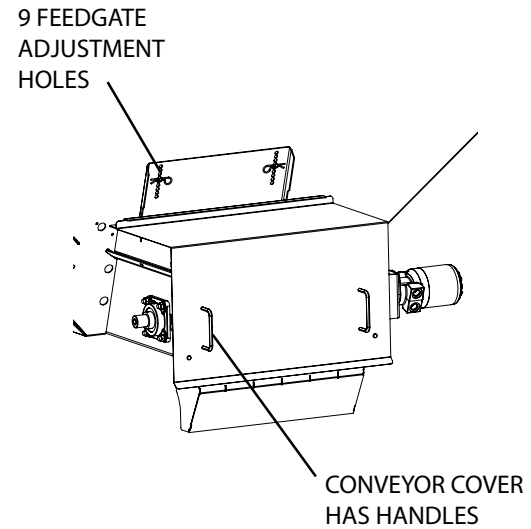

Feedgate Adjustment

WARNING

Stay out of the spreader. If it's necessary to enter the spreader, return to the shop, empty body, turn off all power, set vehicle brakes, lock engine starting switch and remove keys before entering. Tag all controls to prohibit operation. Tags should be placed, and later removed, only by person working in the body.

Adjust the insert's front feedgate prior to installation.

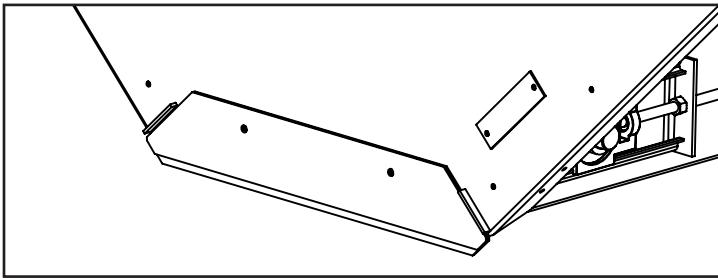

Figure 2A - 1 1/2" (3.81 cm) or 2" (5.08 cm) Opening
(Style I MULTAPPLIER)

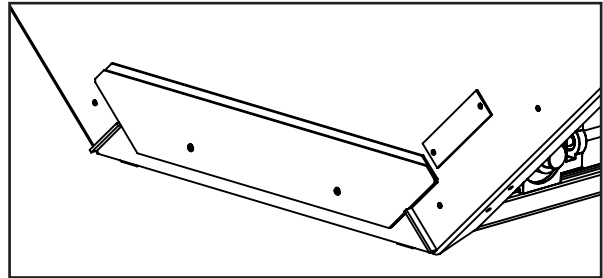

Figure 2B - 3" (7.62 cm) Opening
(Style I MULTAPPLIER)

Style I MultApplier - To adjust main bin's feedgate opening on a Style I MultApplier-equipped unit: position front feedgates on MultApplier as necessary to achieve a 1-1/2 inch (3.81 cm), 2 inch (5.08 cm) (Figure 2A) or 3 inch (7.62 cm) (Figure 2B) opening. Position both feedgates with short side down for a 3" (7.62 cm) opening. NOTE: Both feedgates are installed for shipping.

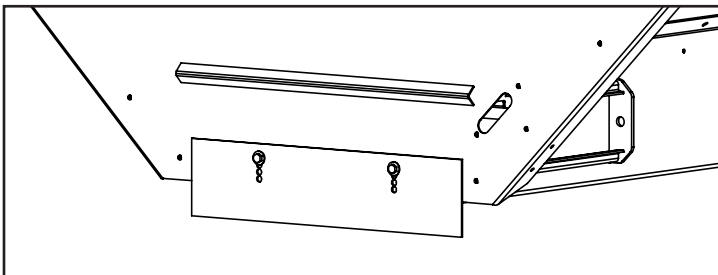

Figure 3A - 2 1/2" (3.81 cm) or 2" (5.08 cm) Opening
(Style II MULTAPPLIER/MULTIBIN)

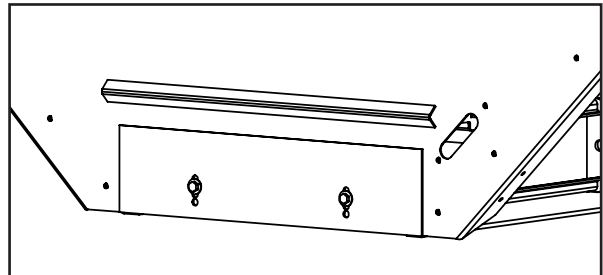

Figure 3B - 4" (10.16 cm) Opening
(Style II MULTAPPLIER/MULTIBIN)

Style II MultApplier/MultiBin - To adjust main bin's feedgate opening on a Style II MultApplier or MultiBin-equipped unit: position front feedgate on insert as necessary to achieve a 1 1/2 inch (3.81 cm) (Figure 3A) to 4 inch (10.16 cm) (Figure 3B) opening in 1/2 inch increments.

NOTE:

Visit www.newleadervip.com and enter parameters to determine minimum and maximum application rates and feedgate openings for optimal performance of your spreader.

Insert Installation

⚠ WARNING

Use only lifting devices that meet or exceed OSHA standard 1910.184. Never exceed work load limits or lift equipment over people. Empty spreader before lifting. Loads may shift or fall if improperly supported. Failure to comply with this requirement could result in death or serious injury.

Before installing the insert:

Parts Needed:

Description	Qty
MultApplier	1
Capscrew - 1/2 x 1 1/4 Grade 8	8
Flat Washer - 1/2 Grade 8	16
Lock Washer - 1/2 Grade 8	8
Hex Nut - 1/2 Grade 8	8

1. Make sure rubber sealer hardware (1) is loose. If not, loosen.

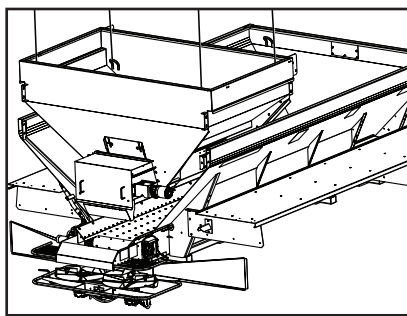
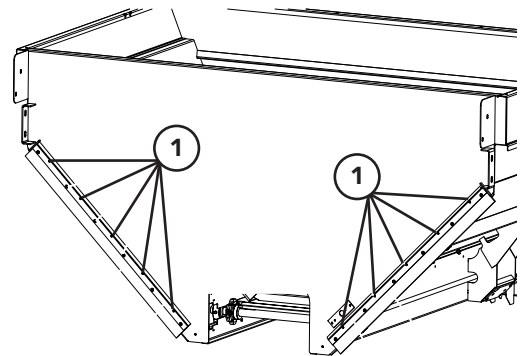

Figure 4A



Figure 4B

2. To install insert:
 - a. Figure 4A - Hoist insert into position and slide between main bin's side sheets.
 - b. Figure 4B - Align insert's and main bin's front and rear mount brackets.
 - c. Make sure insert is resting on inside of main bin, and not resting on tops of side sheets.
 - d. Release tension on hoist but do not remove.

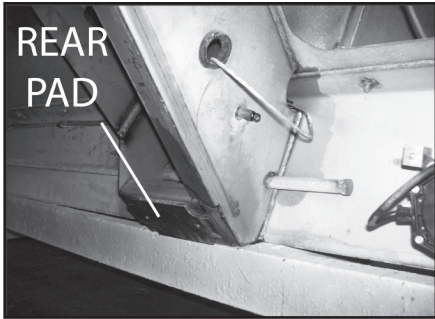

Figure 5A (uninstalled)

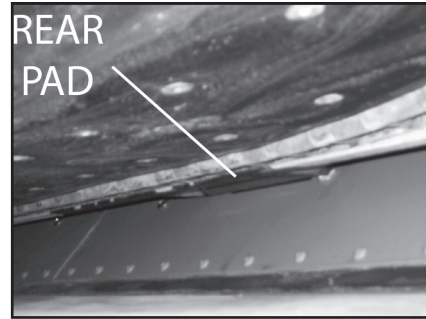

Figure 5B (shown installed)
View from rear of unit.

Figures 5A-5B - Visually make sure insert is centered from side to side in main bin and rear pads are resting on main bin.

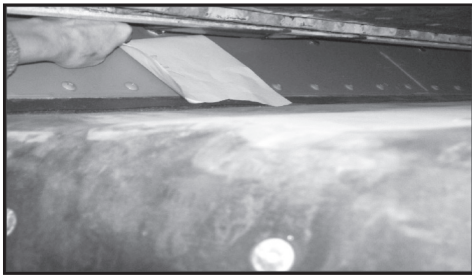

Figure 6

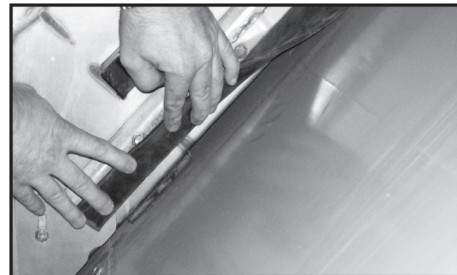

Figure 7

Figure 6 - There must be contact between rear pads and main unit. Check for contact by trying to slide paper between pads and main bin. If no contact, adjust insert.

Figure 7 - Inside main unit, locate front pads by lifting rubber sealers on front endgate.

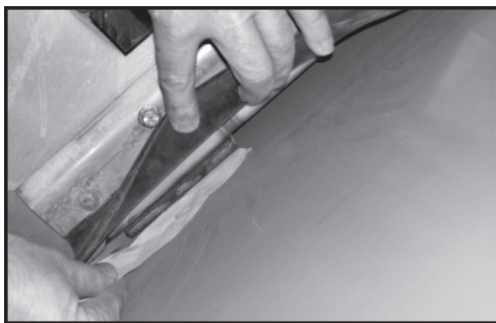

Figure 8A



Figure 8B

1. Figures 8A-8B - There must be contact between front pads and main bin. Check for contact by trying to slide paper between pads and main bin. If no contact, adjust insert.

NOTE: Pry insert at mount brackets if necessary.

Insert Installation



Figure 9



Figure 10



Figure 11

2. Figure 9 - Once both front pads make contact, insert hardware in front mount brackets' lower holes. Shim between main bin and insert brackets if distance is larger than 1/8" (.32cm). Tighten hardware per torque recommendations in this manual.
3. Figure 10 - Make sure front feedgate is level. Lower endgate sealers so flush with chain shields and tighten hardware.

NOTICE

Leakage of material may occur if the sealer belts are not set properly on the front of the insert. Highway Equipment Company is not liable for lost material due to improperly installed sealer belts.

4. Figure 11 - Make sure there is a complete seal covering the gap between the insert and the main bin's side sheets. Tighten all hardware on rubber sealers at front of insert. Make sure rear pads are still in place against main bin. Install hardware in lower holes of rear mount brackets. Shim between main bin and insert brackets if distance is larger than 1/8" (.32cm). Tighten hardware per torque recommendations in this manual.
5. Make sure insert's side sheets are not resting on top of main bin's side sheets.
6. Install hardware in all four mount brackets' upper holes. Tighten hardware per torque recommendations.
7. Remove hoist.
8. Inspect unit for foreign debris in conveyor area.

Lower Divider - Multibin

The following steps apply to MULTIBIN units only. Continue to "Hydraulics" for MULTAPPLIER units.

NOTICE

Highway Equipment Company will not be liable for misapplied material due to an improperly adjusted divider, spreader or both.

Parts Needed:

Description	Qty
Divider - Lower Weldment	1
Capscrew - 5/16 x 1	4
Washer - Flat 5/16	8
Nut - Lock 5/16 SS	4

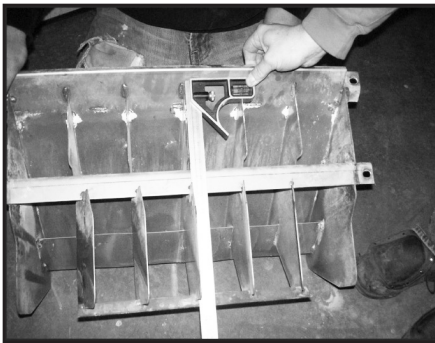

Figure 12

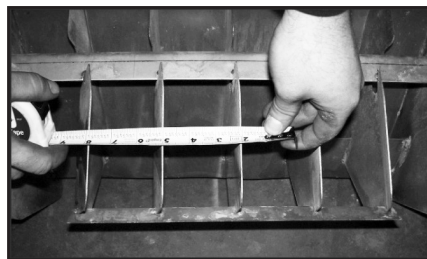

Figure 13



Figure 14

1. Figure 12 - Make sure center fin is square to rear panel.
2. Figure 13 - Measure distance between Lower Divider fins to make sure they are all 3" (8cm) apart. Adjust top of fin as necessary.
3. Figure 14 - Slide Lower Divider between bottom of MULTIBIN and Spinner Divider as shown.
4. Figure 15 - Lift Lower Divider to bottom of MULTIBIN, align holes and loosely install front and rear hardware.
5. Figure 16 - Verify Lower Divider is square by measuring from each side to main bin's chain shields. Make sure distances are equal.
6. Make sure Lower Divider is centered over Material Divider. Contact Highway Equipment Company if they cannot be aligned.
7. Tighten front and rear hardware per torque recommendations. Refer to "Standard Torques" in the "Lubrication and Maintenance" section of the spreader manual.



Figure 15

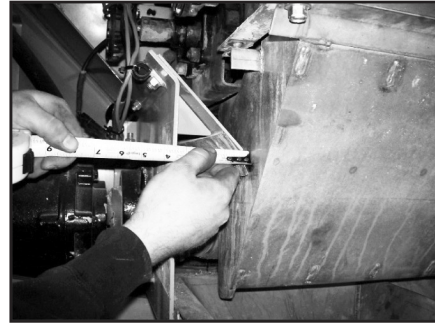

Figure 16

Insert Installation

Hillside Divider & Conveyor Cover - MultiApplier

The following steps apply to MULTAPPLIER units only. Continue to "Micro Cover Installation" for MULTIBIN units.

NOTICE

Highway Equipment Company will not be liable for misapplied material due to an improperly adjusted divider, spreader or both.

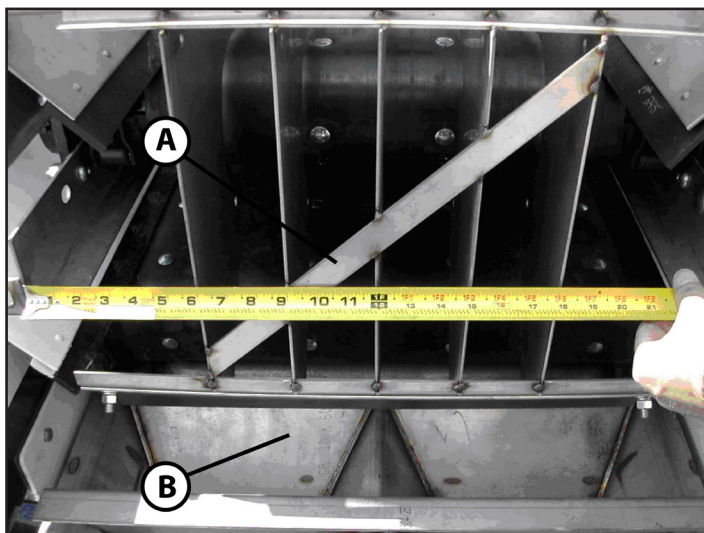
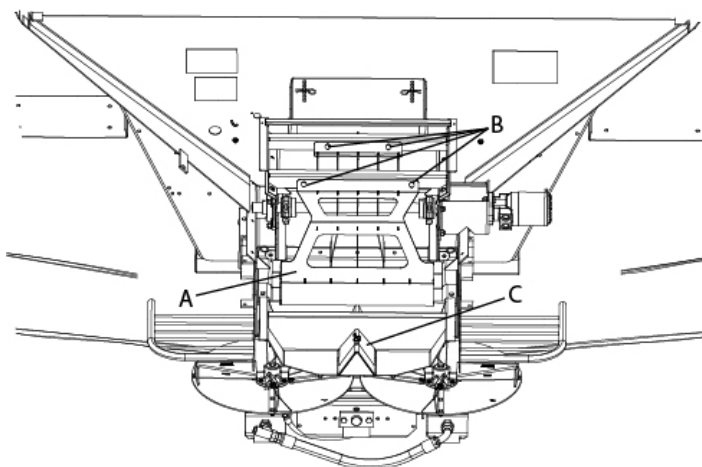

Figure 19A - MULTAPPLIER Hillside Divider (Style I)

Style I MultiApplier - Remove hardware from rear two chain shield holes on each side of MultiApplier and set aside. Install MultiApplier Hillside Divider (A) over conveyors and attach using chain shield hardware. Adjust Hillside Divider so that the middle divider is centered over both conveyors and the Material Divider (B) as shown in Figure 19A. Tighten hardware to recommended torque.

Figure 19B - MULTAPPLIER Hillside Divider (Style II)



Style II MultiApplier - Loosen hardware from rear two chain shield holes on each side of MultiApplier. Install MultiApplier Hillside Divider (A) and fasten to Support using single bin Hillside Divider hardware removed before MultiApplier installation (B). Adjust Hillside Divider so that the middle divider is centered over both conveyors and the Material Divider (C) as shown in Figure 19B. Tighten all hardware to recommended torque.

Micro Cover Installation

Air Supply and Electrical Requirements

Auxiliary Supply Line	Electrical Connections
Dry Air - 85 PSIG (5.86 Bar)	Red = 12 V (+) Black = Ground (-)

Refer to "MultiBin Lid Pneumatics" in the spreader parts manual for air line connections.

Make sure all hardware on insert is torqued before installing cover.



WARNING

Pressurized air may cause sudden movement of parts. Do not service cover components until safety precautions have been performed.

Take preventative measures to prevent falling or runaway of cylinder or mechanism before maintenance and restart of spreader.

Exhaust all residual air and cut the pressure supply for components before servicing. Injury can occur if precautions are not taken. Failure to comply with this requirement could result in death or serious injury.



WARNING

Open cover lid with air prior to removing actuator pin and block cover lid to prevent closing. Unintentional closing could cause injury. Failure to comply with this requirement could result in death or serious injury.

Fasten a three-point lifting device to two lift hooks and one hole in guide mount as shown in Figure 20. Hoist cover onto MULTI BIN as shown in Figure 21. Align slots and attach hardware. Tighten to recommended torque. Secure fittings and airline tubing on MULTI BIN with wire ties as shown in Figure 22. Connect to air and electrical systems. Open lid and install additional hardware inside cover. Install screens.

Refer to "Air Schematic" page in the Troubleshooting section for air supply requirements.

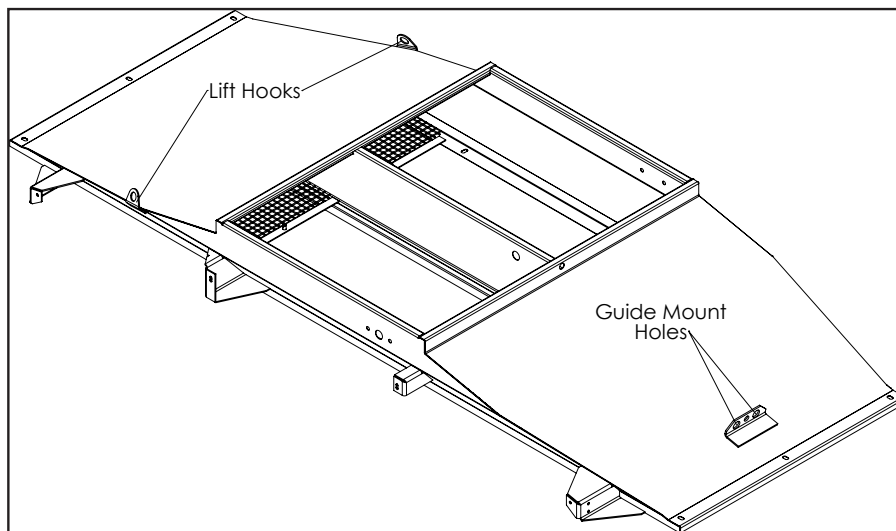

Figure 20 - Lift Hooks & Guide Mount

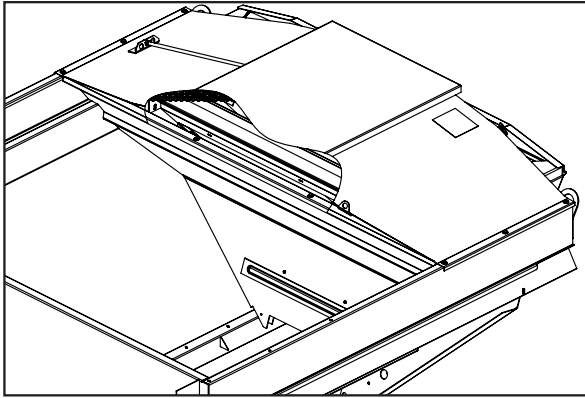

Figure 21 - Cover Placement

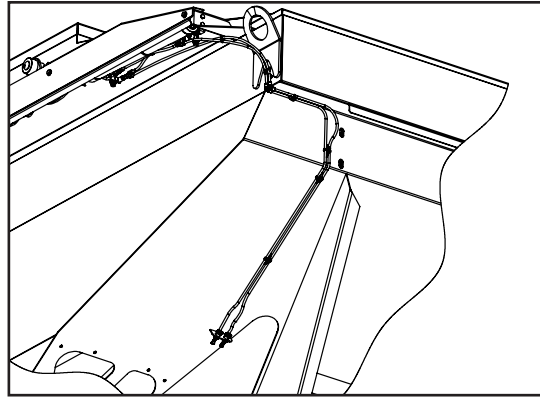

Figure 22 - Cover Airline Tubing

Hydraulics

Attach insert hoses to spreader hoses as shown in Figures 17A - 17C as applicable. Plug in rate sensor.

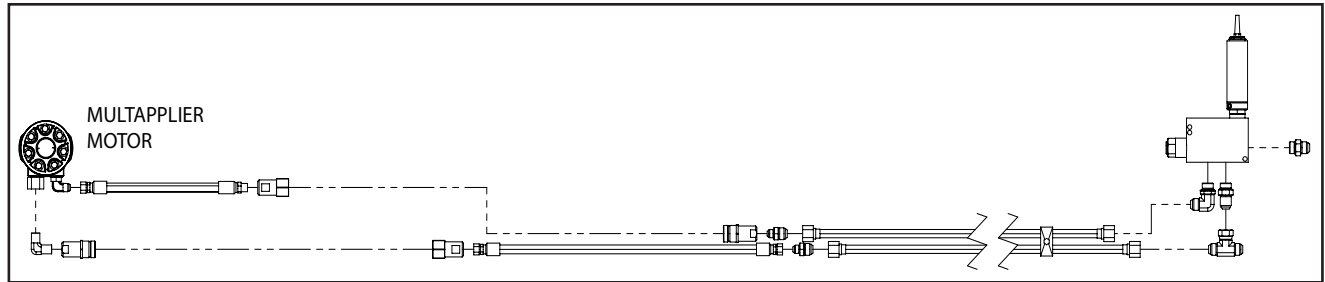

Figure 17A - MULTAPPLIER Operation

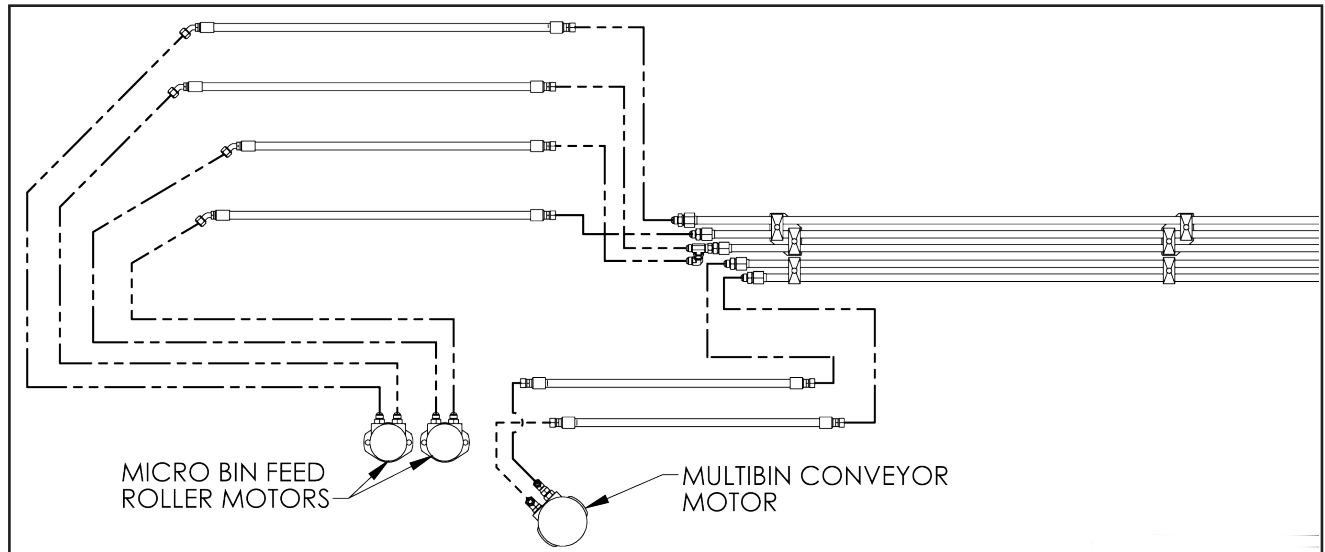

Figure 17B – MULTIBIN Operation Dual Micro

Insert Installation

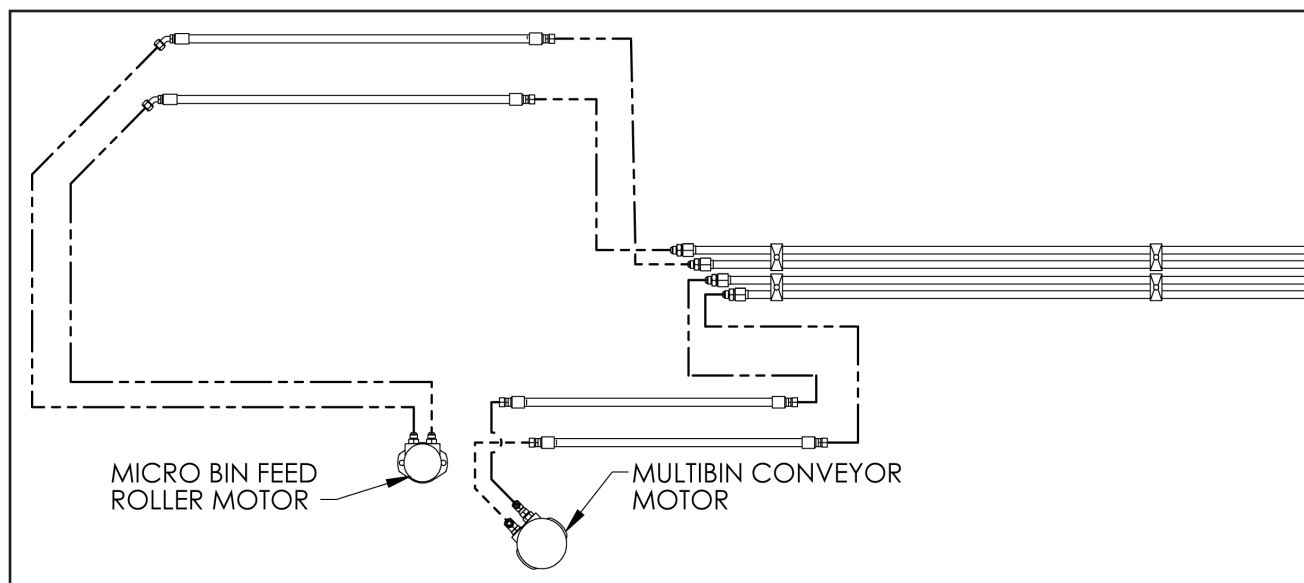

Figure 17C – MULTI BIN Operation Single Micro

Hydraulic Hose Installation

Refer to “Installation Guide” for proper hydraulic hose installation guidelines.

If insert was purchased separately from spreader, refer to parts pages for hydraulic installation. Install valve mounting bracket on two right hand front stakes as shown in Figure 18 (MultiBin installation shown).

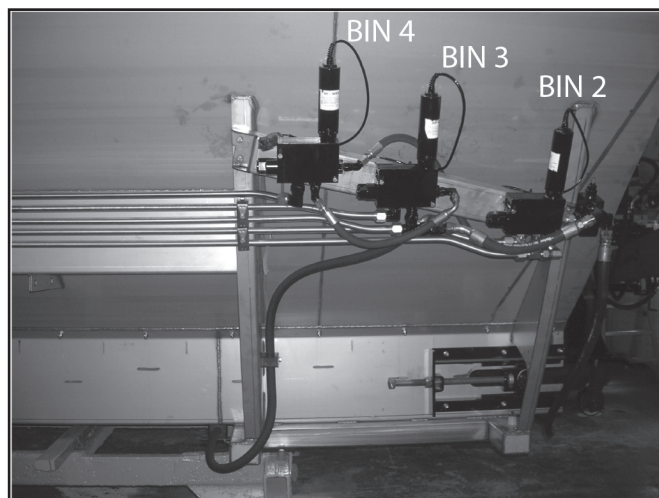

Figure 18 - Hydraulic Installation

Insert Installation

Install Valve Bracket

Parts Needed:	
Description	Qty
Mounting Bracket	1
Capscrew - .375-16NC X 1 SS	4
Flat Washer - .375 SS	4
Lock Nut - .375-16NC SS	4

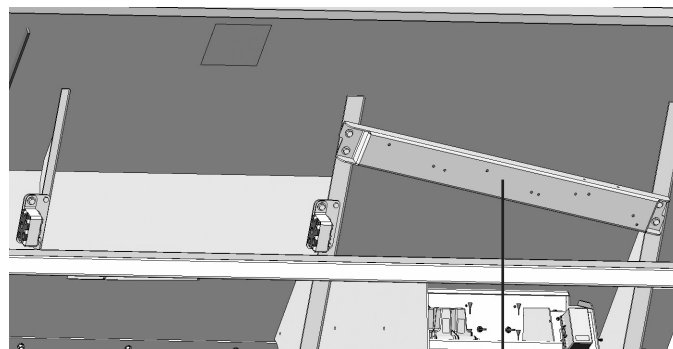

Figure 1 - Mounting Bracket

1

1. Install Bracket (1) using associated hardware.
2. Tighten hardware per torque recommendations.

NOTE: Procedure shown is for MultApplier. Multi Bin process is similar.

Install Valve

Parts Needed:	
Description	Qty
Valve	1
Capscrew - .25-20NC X 3.25 SS	2
Washer - .25 ID X .40 OD X .13 THK SS	2
Washer - .25 ID X .40 OD X .5 THK SS	2
Lock Nut - .25-20NC SS	2

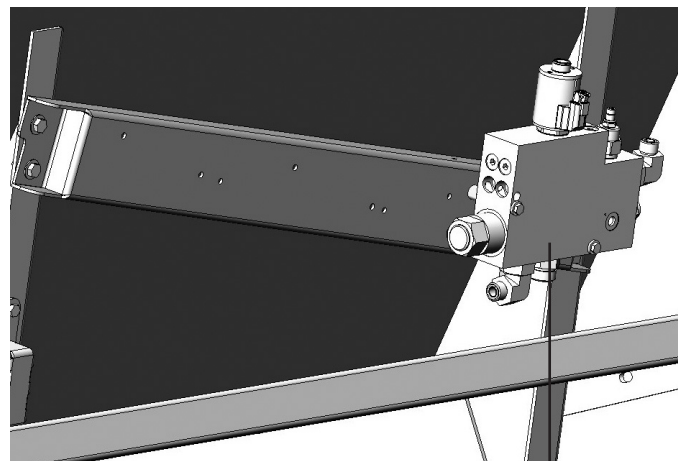

Figure 1 - Valve

1

1. Install Valve (1) using associated hardware.
2. Tighten hardware per torque recommendations.

NOTE: Procedure shown is for MultApplier. Multi Bin process is similar.

Install Clamp Assemblies

Parts Needed:	
Description	Qty
Plate	4
Bar Tube Clamp	4
Rubber Insert	4
Capscrew - .313-18NC X 1 SS	8
Capscrew - .375-16NC X 1.25 SS	4
Flat Washer - .313 SS	8
Flat Washer - .375 SS	4
Lock Nut - .313-18NC SS	8
Lock Nut - .375-16NC SS	4

1. Install Plate (1) using associated hardware.
2. Insert tubing into Rubber Insert (2).
3. Secure in place with Bar Tube Clamp (3).
4. Tighten hardware per torque recommendations.

NOTE: Procedure shown is for MultiApplier. Multi Bin process is similar.

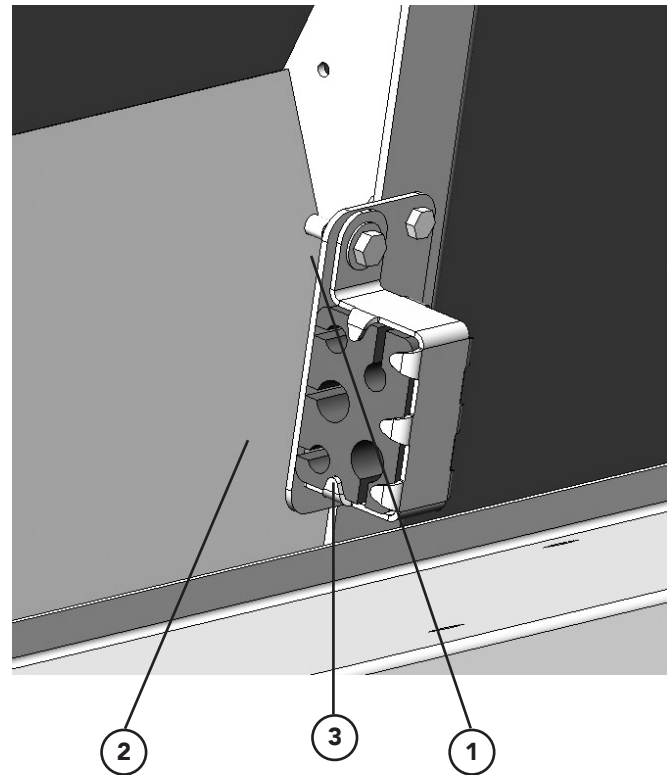

Figure 1 - Clamp Assembly

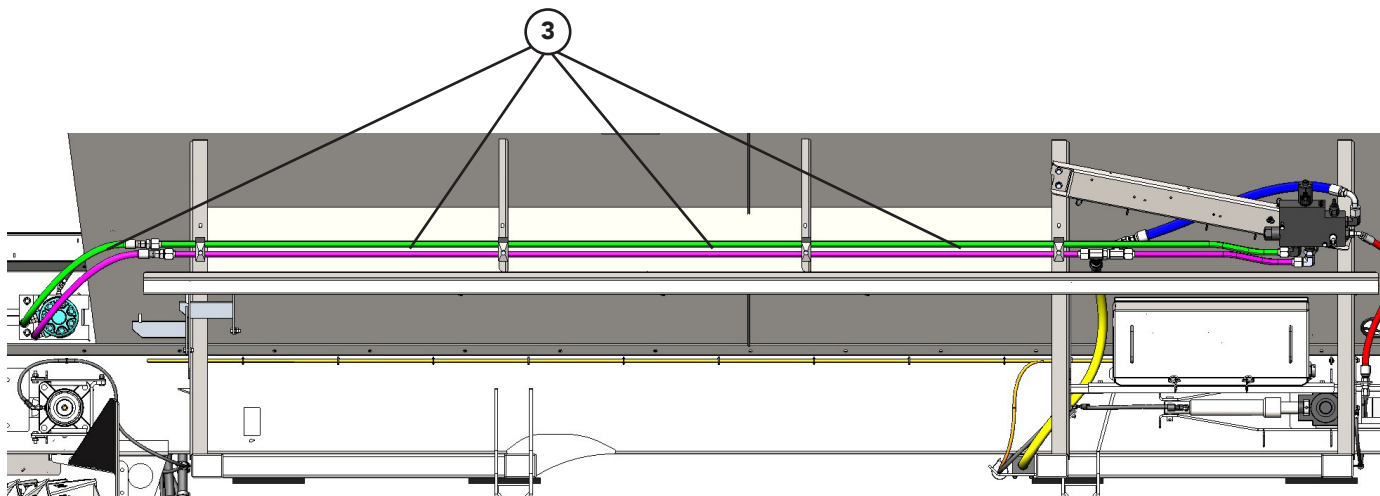

Figure 2 - Clamp Assemblies

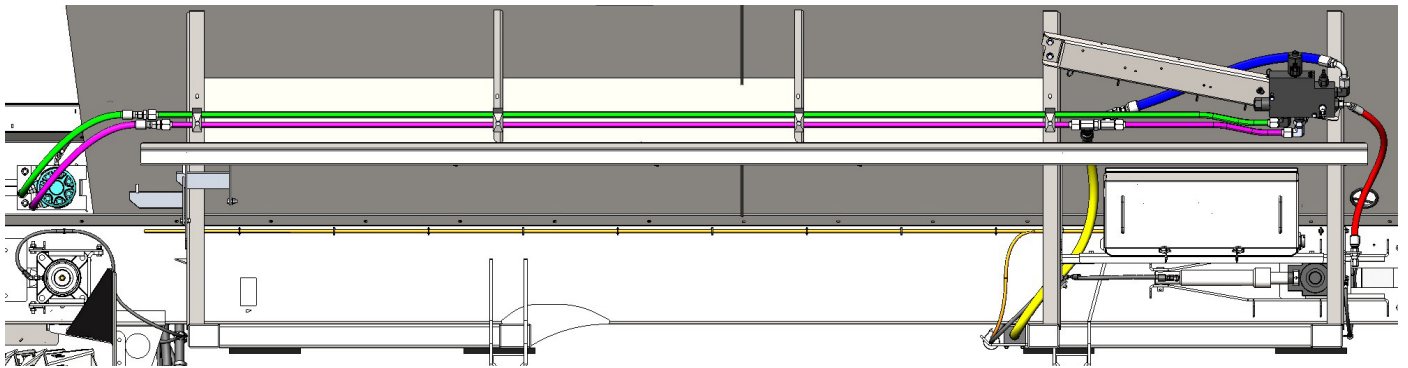

Figure 1A - MULTAPPLIER Right Side

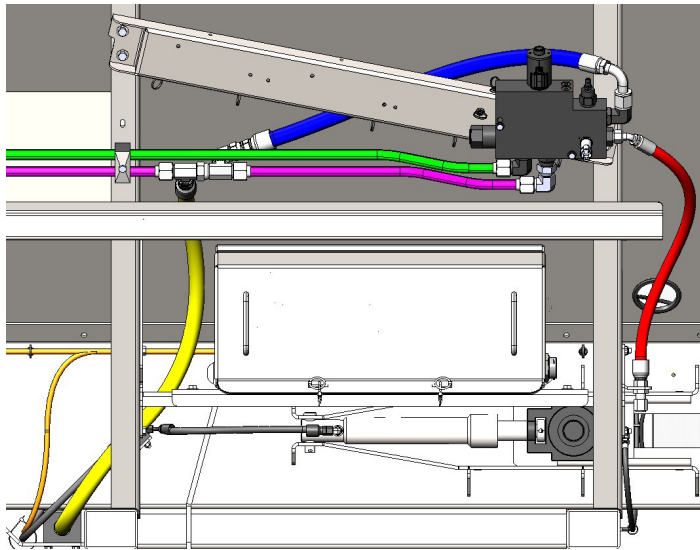

Figure 1B - MULTAPPLIER Valve Assy Connections

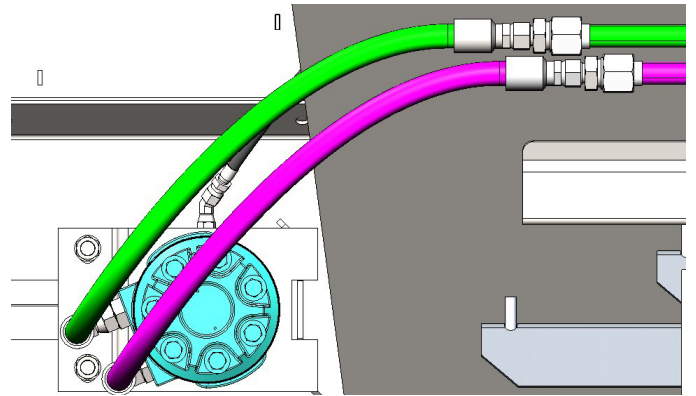

Figure 1C - MULTAPPLIER Motor Connections

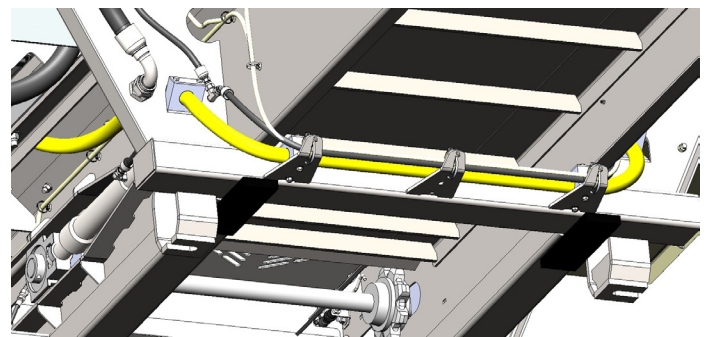

Figure 1D- MULTAPPLIER/MULTIBIN Front Underneath Tank Routing

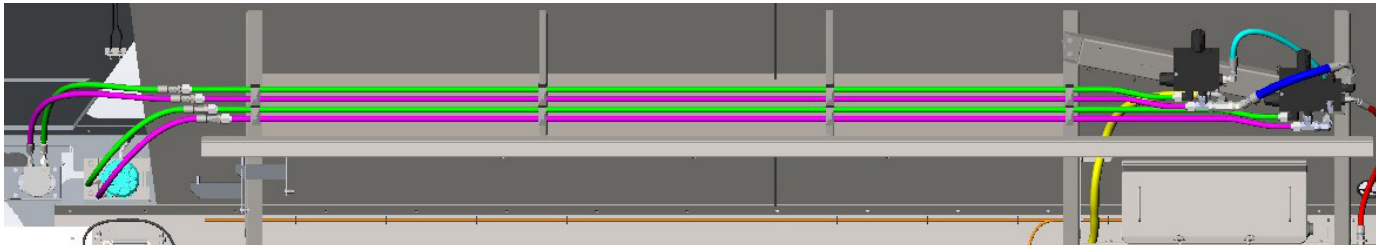

Figure 2A - 3-BIN Right Side

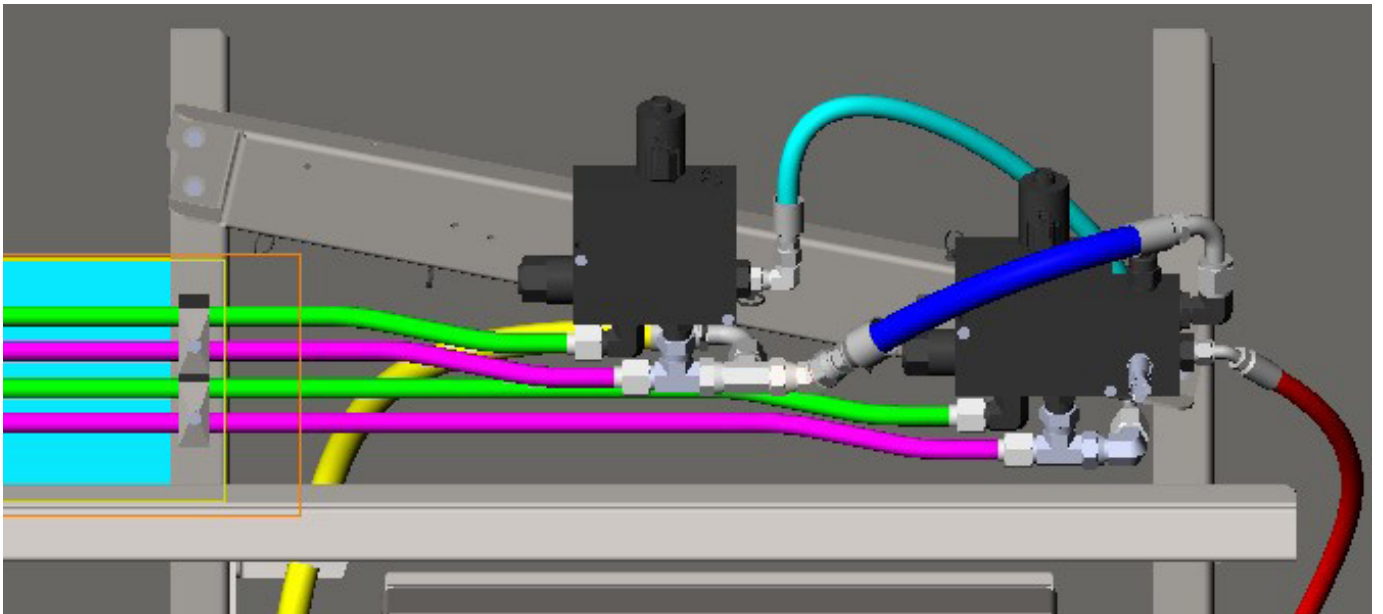

Figure 2B - 3-BIN Valve Assy Connections

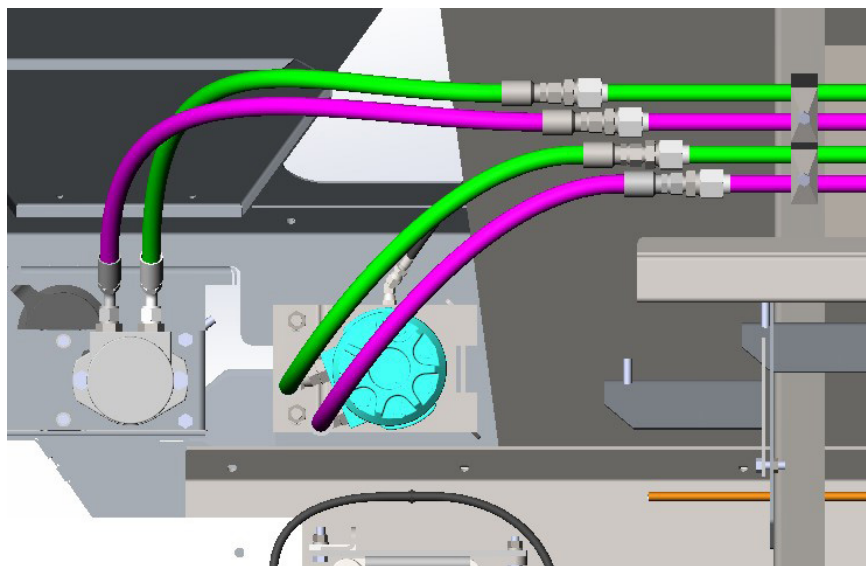

Figure 2C - 3-BIN Motor Connections

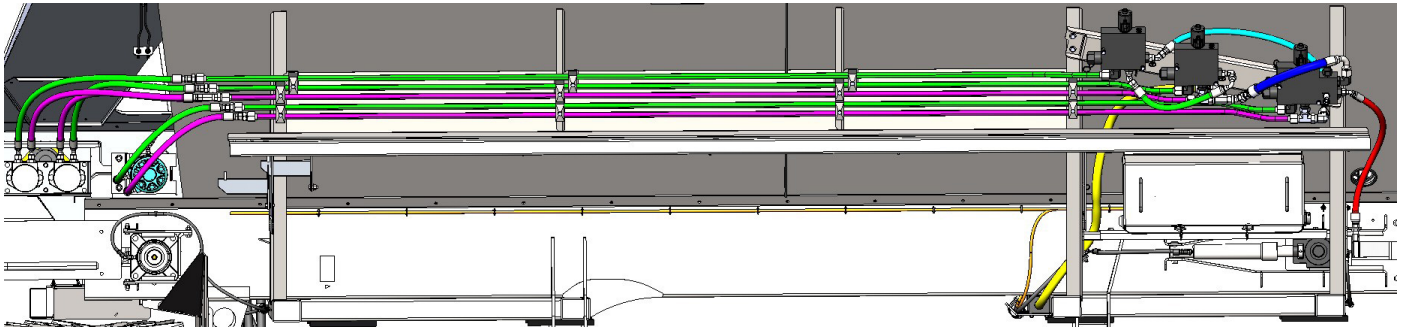

Figure 3A - 4-BIN Right Side

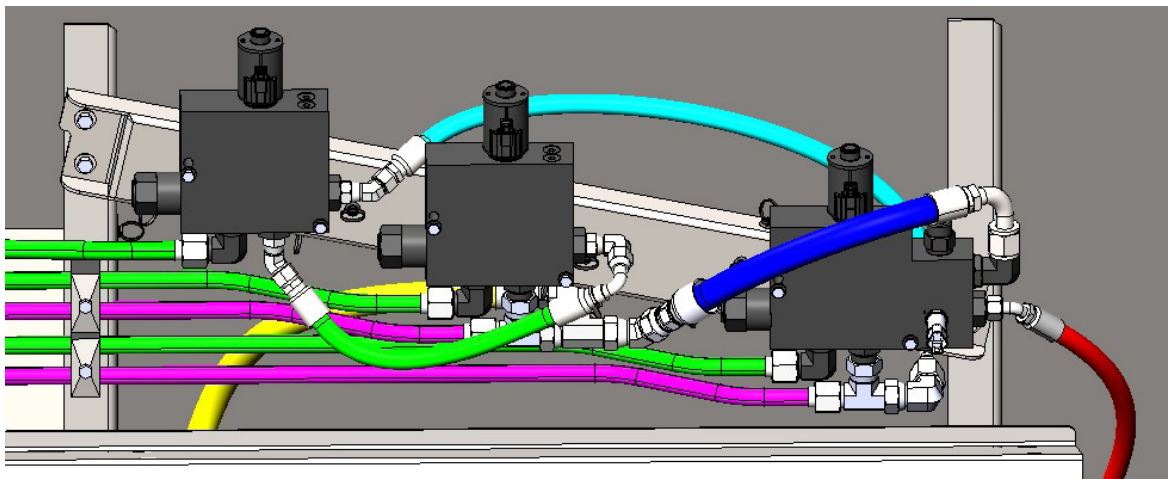

Figure 3B - 4-BIN Valve Assy Connections

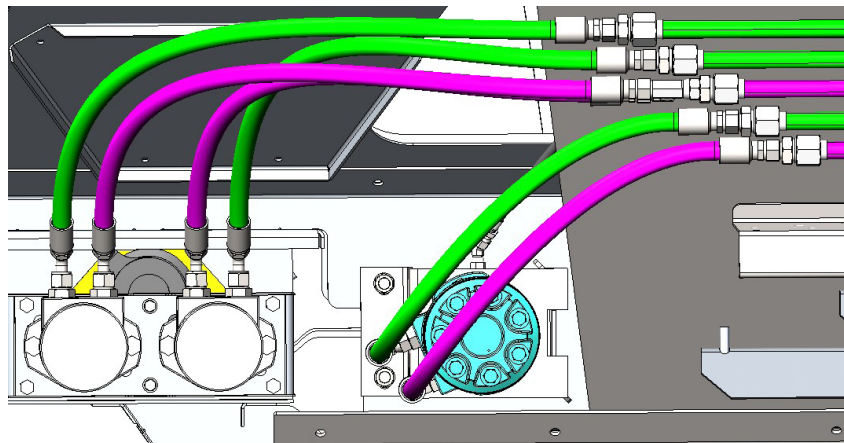

Figure 3C - 4-BIN Motor Connections

Insert Removal/Endgate Installation

Remove insert and reinstall endgate, Inverted "V", single conveyor Hillside Divider, etc. by following applicable installation instructions in reverse order. Make sure the insert hydraulics, electrical connections and air lines are disconnected from the spreader before removal. See "Inverted V" in spreader parts manual.

Hydraulics Removal

Route hydraulic hoses on the spreader and the insert as shown in Figures 23A - 23C as applicable.

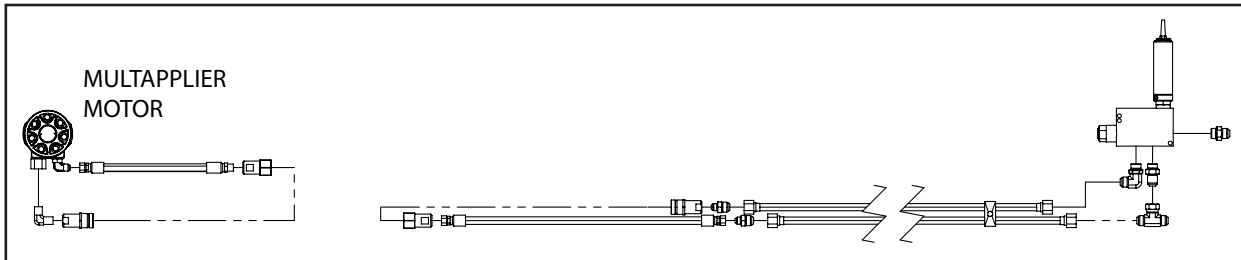

Figure 23A -Detach MULTAPPLIER

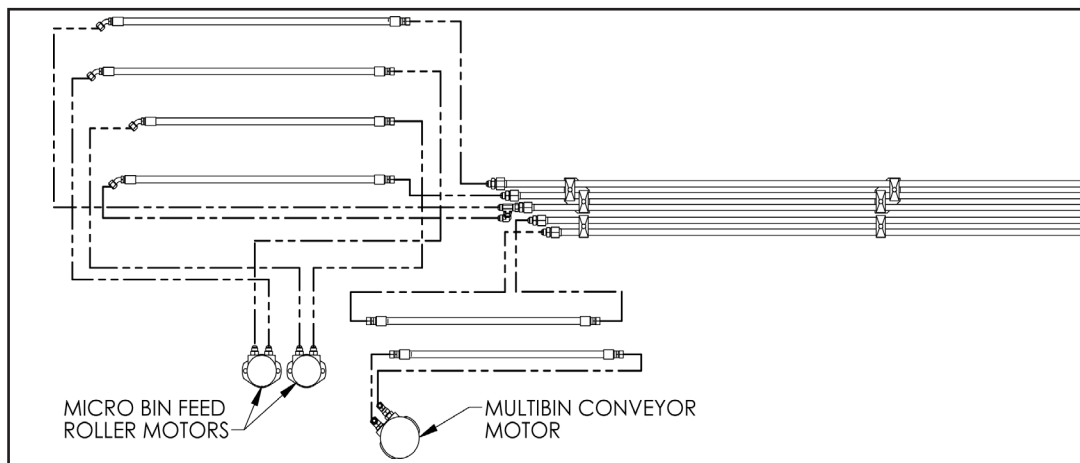

Figure 23B - Detach MULTIBIN Dual Micro

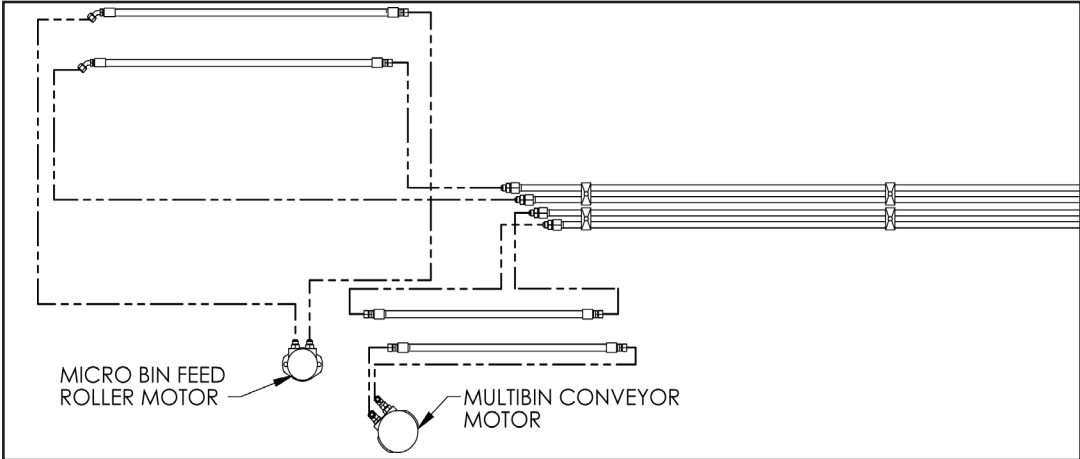

Figure 23C – Detach MULTIBIN Operation Single Micro

This page is intentionally left blank.

OPERATIONS

OPERATIONS

General Description

The L4000G4 is a hopper type spreader intended for spreading free flowing granular agricultural materials, such as chemical fertilizers, agricultural limestone, and gypsum. It is intended for agricultural vehicle mounting.

The unit is powered hydraulically and provides variable speed control for the spinner and full automatic ground speed control for the conveyor.

The conveyor delivers material to the spinners through an adjustable metering gate at the rear of the hopper body. Orbital type hydraulic motors mounted to 6 to 1 ratio spur gear case on the L4000G4 drive the conveyor. The conveyor options include a pintle type chain joined by cross bars every (#3) link or a belt-over-chain type having parallel strands of pintle type (#4) chain joined by cross bars every other link.

The spinner assembly has two 24-inch (610mm) diameter dished discs. Each disc has four formed and heat treated fins that are adjustable to radial angle. The spinner is fully adjustable by means of a rotating handle.

The optional 304 stainless steel hopper style spreader MultApplier or MultiBin may be inserted in the main bin.

Inserting the MultApplier allows for two materials to be spread simultaneously. It features a 24-inch (610mm) belt-over-chain type conveyor having parallel strands of pintle type (#4) chain joined by cross bars every other link. The direct driven conveyor is also controlled independently enabling the delivery of material at variable rates through the adjustable gate at the rear of the hopper body. The hillside divider improves material placement on the spinner for a more effective spread pattern.

Inserting the MultiBin will convert the spreader to a 3 or 4 hopper unit, which can be used independently or together for straight and variable rate applications. The front two hoppers dispense fertilizer products while the single or dual hopper at the rear dispense(s) micronutrients or seeding products. The rear bin(s) are sloped forward to improve chassis weight distribution. Material is delivered from the front bin by conveyor and from the rear bin(s) by passing through a meter wheel, material dividers and main spinner assembly with 24-inch (610mm) diameter dished discs. Bin sensors are installed to warn when materials are low in each micronutrient bin.

The MultiBin also comes equipped with an upper and lower material divider which improves material placement on the spinner for a more effective spread pattern.

An optional micronutrient stainless steel cover which opens and closes with a stainless steel air cylinder is available.

Screens installed on micronutrient bins keep large chunks of material out of the bins by breaking the material up as it enters the bins.

This product is intended for commercial use only.

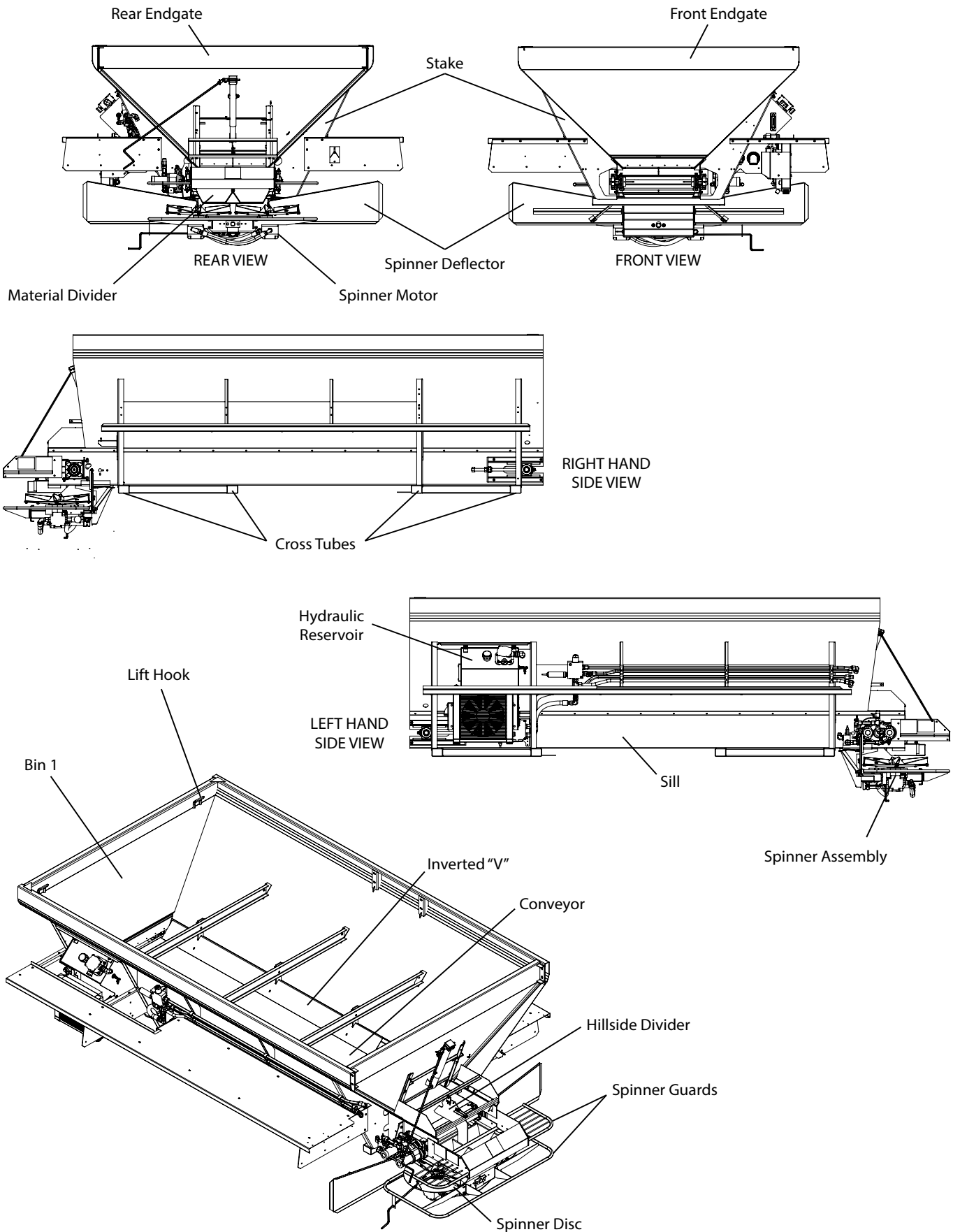

Stake: Side support for main hopper walls.

Rear Endgate: Welded or bolt-in endgate (depending on model) furthest from chassis cab (Rear based on direction of travel). Holds mounted Feedgate, allowing for rear release of material from bin.

Bin 1: Main holding bin for material or Insert. MultiApplier and MultiBin inserts (shown on following pages) are configured as Bins 2-4 depending on type used.

Feedgate: Adjustable gate mounted into Rear Endgate. Allows for variable rates of material flow by adjusting jack to desired height.

Conveyor: Conveys material to rear of unit.

Inverted "V": Mounted inside Main Hopper when Insert not installed. Distributes weight pressure across conveyor, allowing for consistent material flow to Feedgate, and promotes an improved blend when spreading fertilizer.

Material Divider: Ensures uniform spread pattern by directing material off of conveyor onto spinner discs.

Hillside Flow Divider: Ensures balanced flow of material across conveyor when on hillsides or uneven terrain.

Sill: Base of Main Hopper side walls. Contains Conveyor and supports machine walls.

Cross Tubes: Supports body, attaches to Chassis frame. Transfers weight from Main Hopper to Chassis.

Spinner Assembly: Contains adjustable G4 Spreader system, consisting of hydraulic spinners used for dispersal of various materials at different positioned settings allowing for consistent, even spread patterns across a wide variety of materials with a high rate of accuracy.

Spinner Guards: Upper and Lower guards, protects operators from spinner discs. Must be in place during any operation.

Spinner Deflectors: Deflect material away from machine.

Lift Hooks: Used to lift unit or insert with appropriately rated lifting device.

MULTAPPLIER

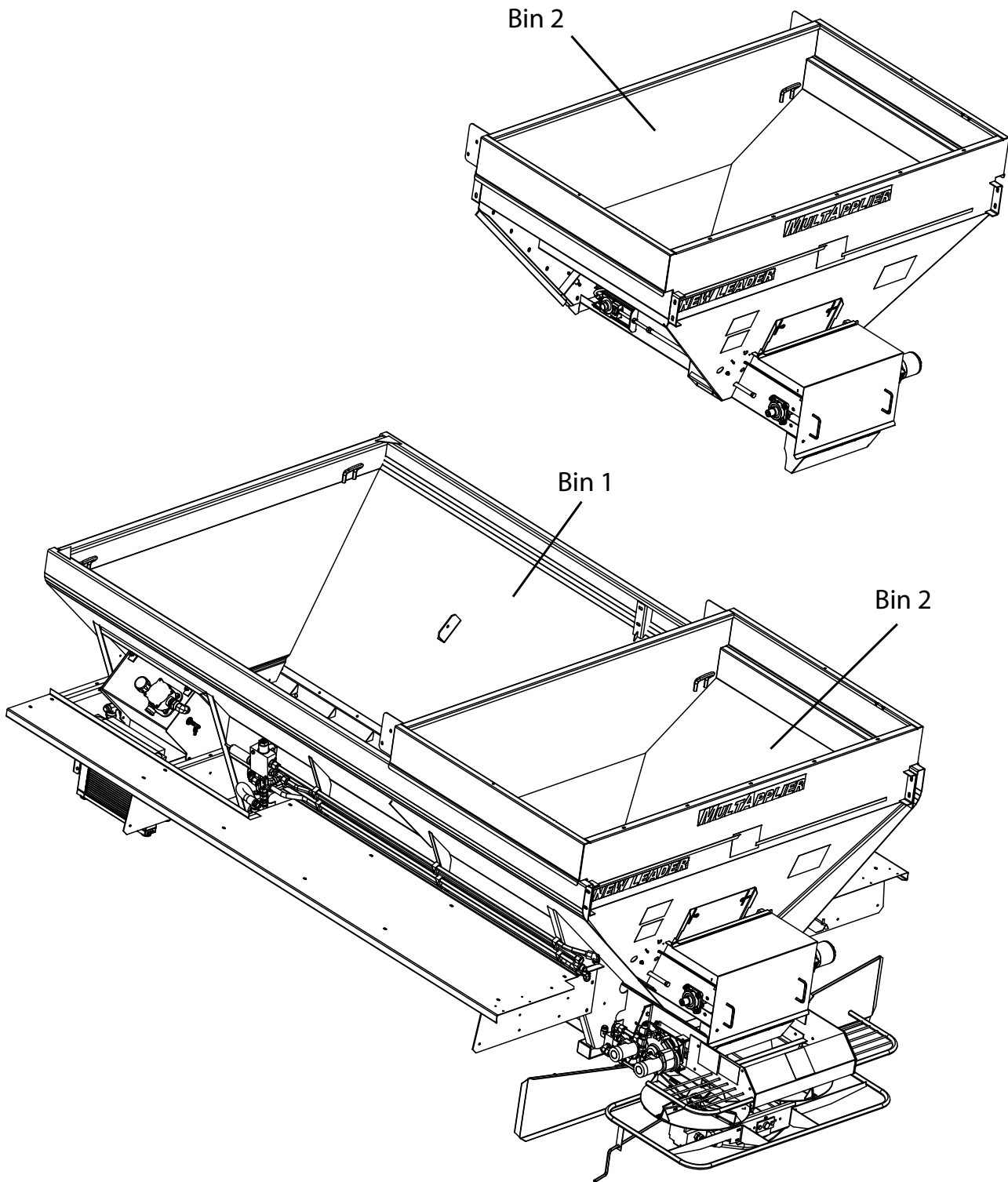

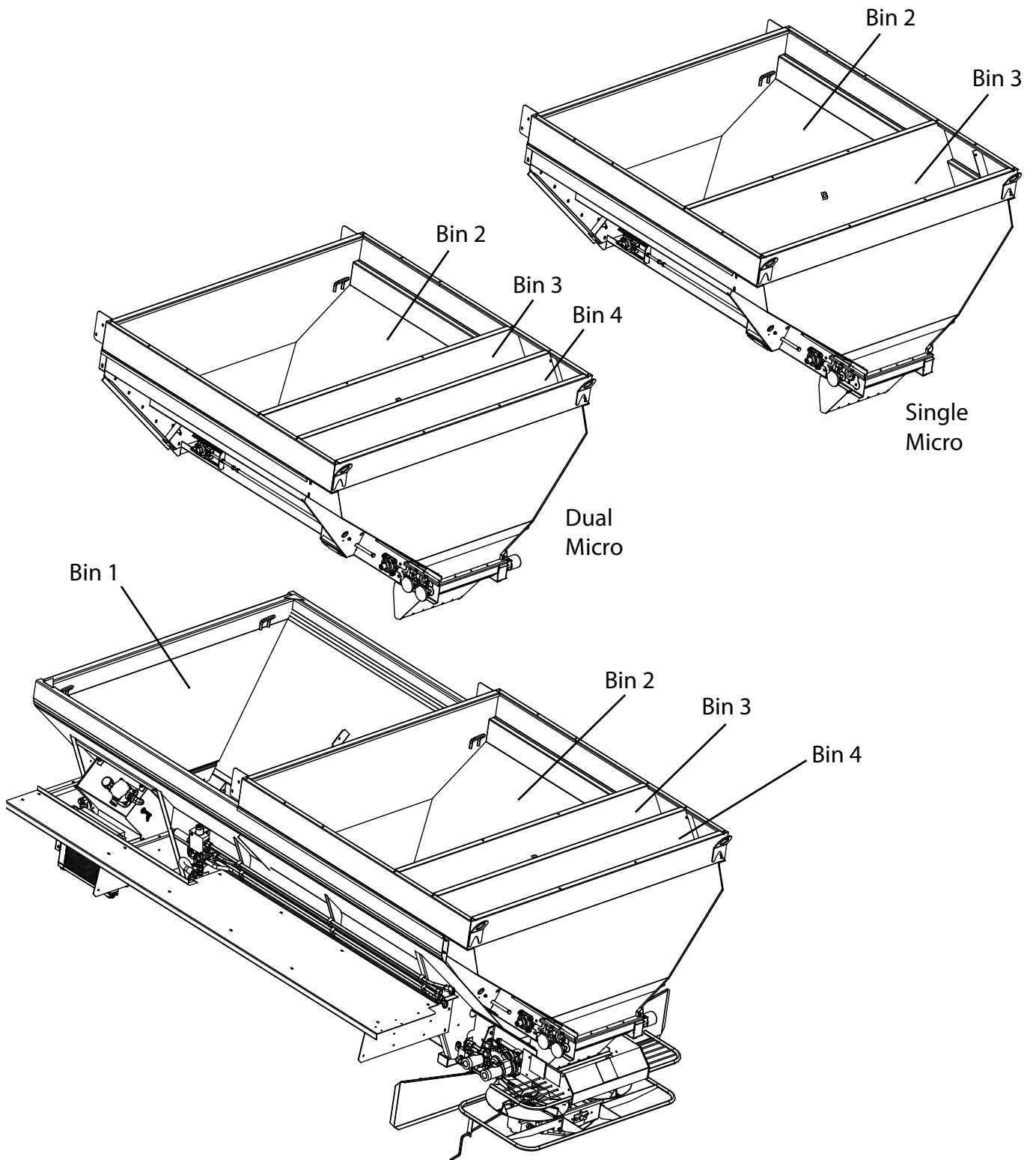

L4000G4, SINGLE BIN

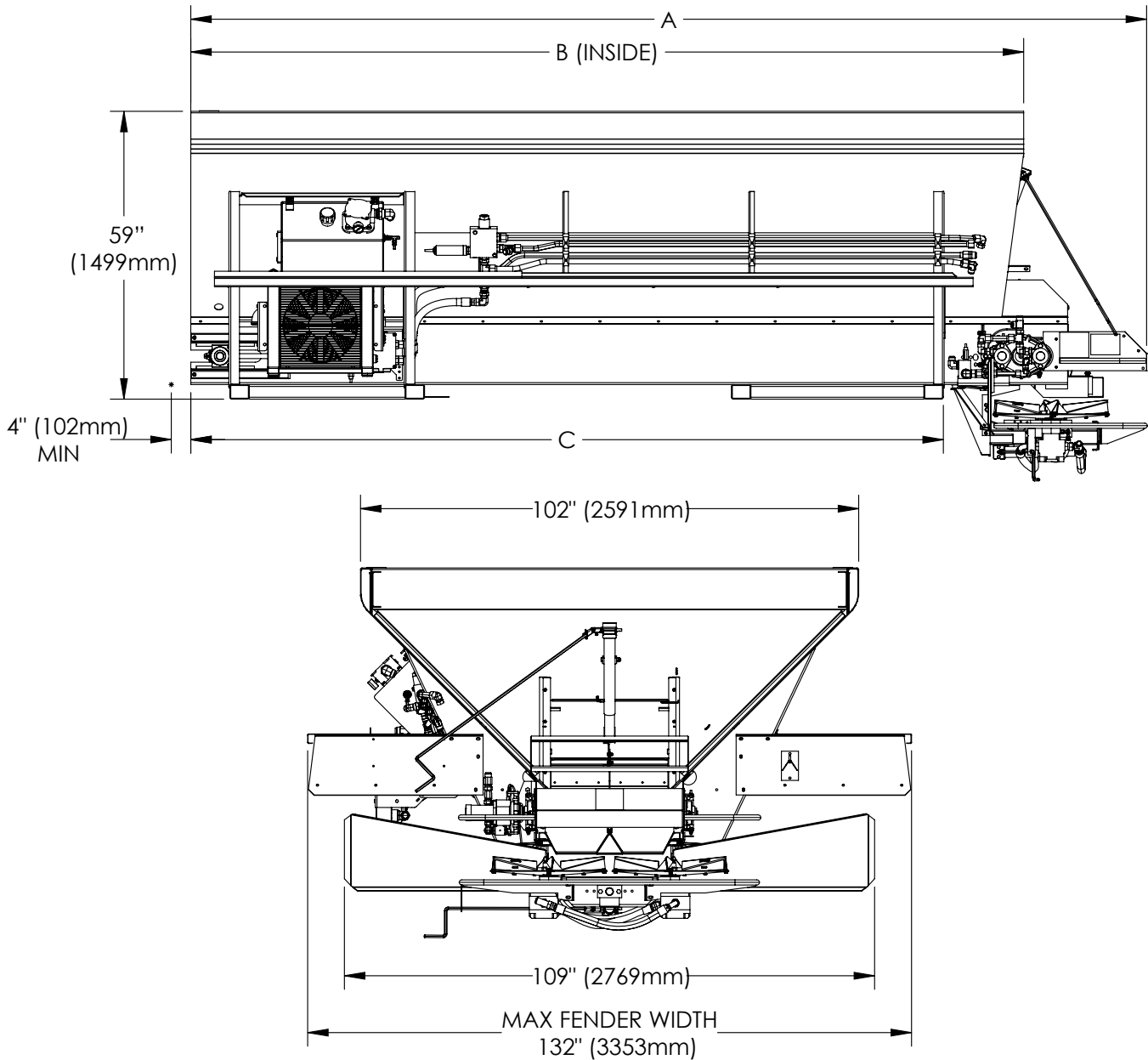

IMPORTANT!

Please consult federal, state, and local weight laws and chassis manufacturer's ratings to ensure neither government weight restrictions nor GVWR and GAWR's are exceeded. Tire and tandem axle size may require mounting modification of optional mud flaps.

L4000G4, SINGLE BIN WEIGHTS & CAPACITIES

Unit Length	Overall Length A	Inside Length B	Frame Length C	Approximate Weight Lbs (Kg)	Struck Capacity Cu Ft (Cu M)
13' (3.96m)	184" (4674mm)	156" (3962mm)	143" (3632mm)	3700 (1682)	278 (7.87)
14' (4.27m)	196" (4978cmm)	168" (4267mm)	155" (3937mm)	4000 (1819)	300 (8.50)

L4000G4 WITH MULTAPPLIER

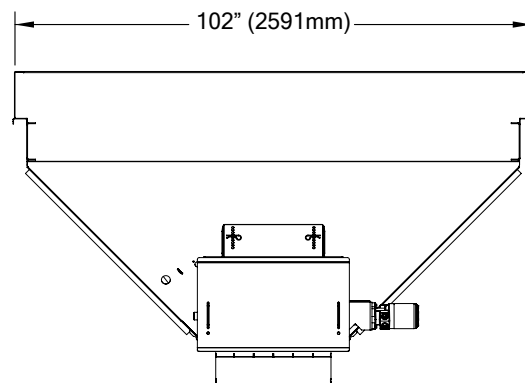
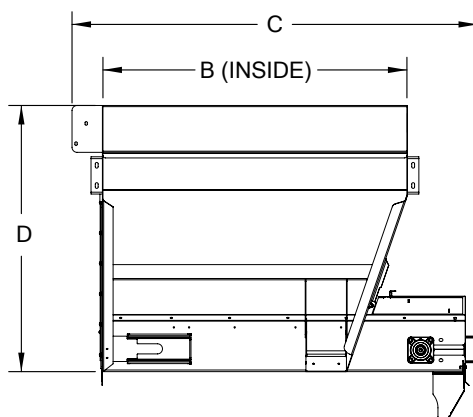
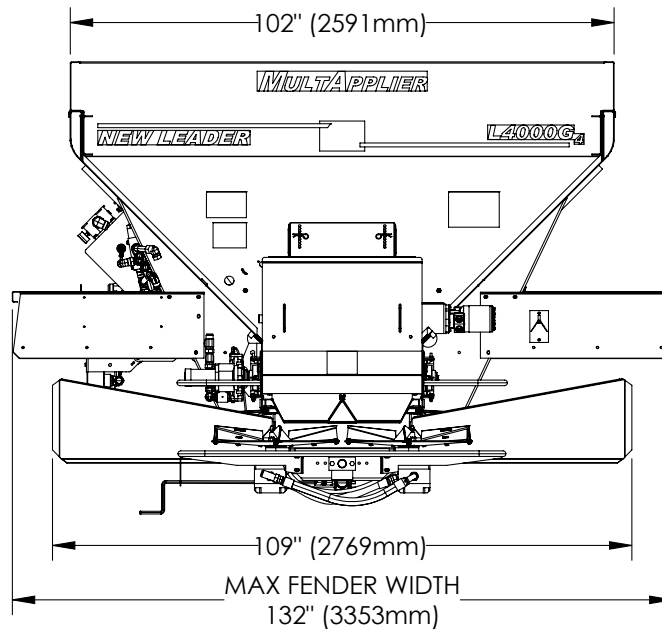
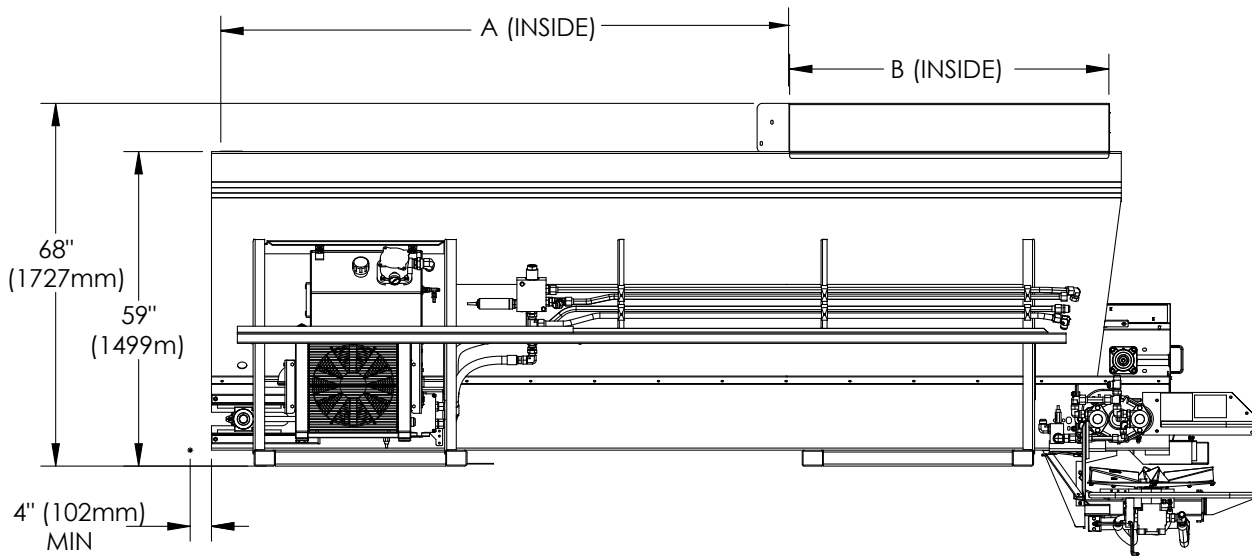

L4000G4 WITH MULTAPPLIER WEIGHTS & CAPACITIES

	With 5' MultApplier	With 5' * MultApplier	With 7' MultApplier	With 7' * MultApplier
Unit Length	Approximate Weight Lbs (Kg)	Struck Capacity Cu Ft (Cu M)	Approximate Weight Lbs (Kg)	Struck Capacity Cu Ft (Cu M)
13' (3.96m)	4400 (2000)	226 (6.40)	4600 (2091)	168 (4.76)
14' (4.27m)	4700 (2137)	255 (7.22)	4900 (2228)	197 (5.58)

STYLE I MULTAPPLIER ALONE DIMENSIONS & CAPACITIES

Insert Unit Length	Inside Length A	Inside Length B	Overall Length C	Height D	Approximate Weight Lbs (Kg)	Struck Capacity Cu Ft (Cu M)
5' (1.52m)	96" (2438mm)	60" (1524mm)	78" (1981mm)	54" (1372mm)	1000 (455)	115 (3.25)
7' (2.13m)	84" (2134mm)	84" (2134mm)	102" (2591mm)	54" (1372mm)	1200 (546)	161 (4.56)

STYLE II MULTAPPLIER ALONE DIMENSIONS & CAPACITIES

Insert Unit Length	Inside Length A	Inside Length B	Overall Length C	Height D	Approximate Weight Lbs (Kg)	Struck Capacity Cu Ft (Cu M)
5' (1.52m)	96" (2438mm)	60" (1524mm)	80" (2032mm)	53" (1346mm)	1100 (500)	115 (3.25)
7' (2.13m)	84" (2134mm)	84" (2134mm)	104" (2642mm)	53" (1346mm)	1300 (591.0)	161 (4.56)

* Struck Capacity Includes Sideboards

L4000G4 WITH MULTIBIN

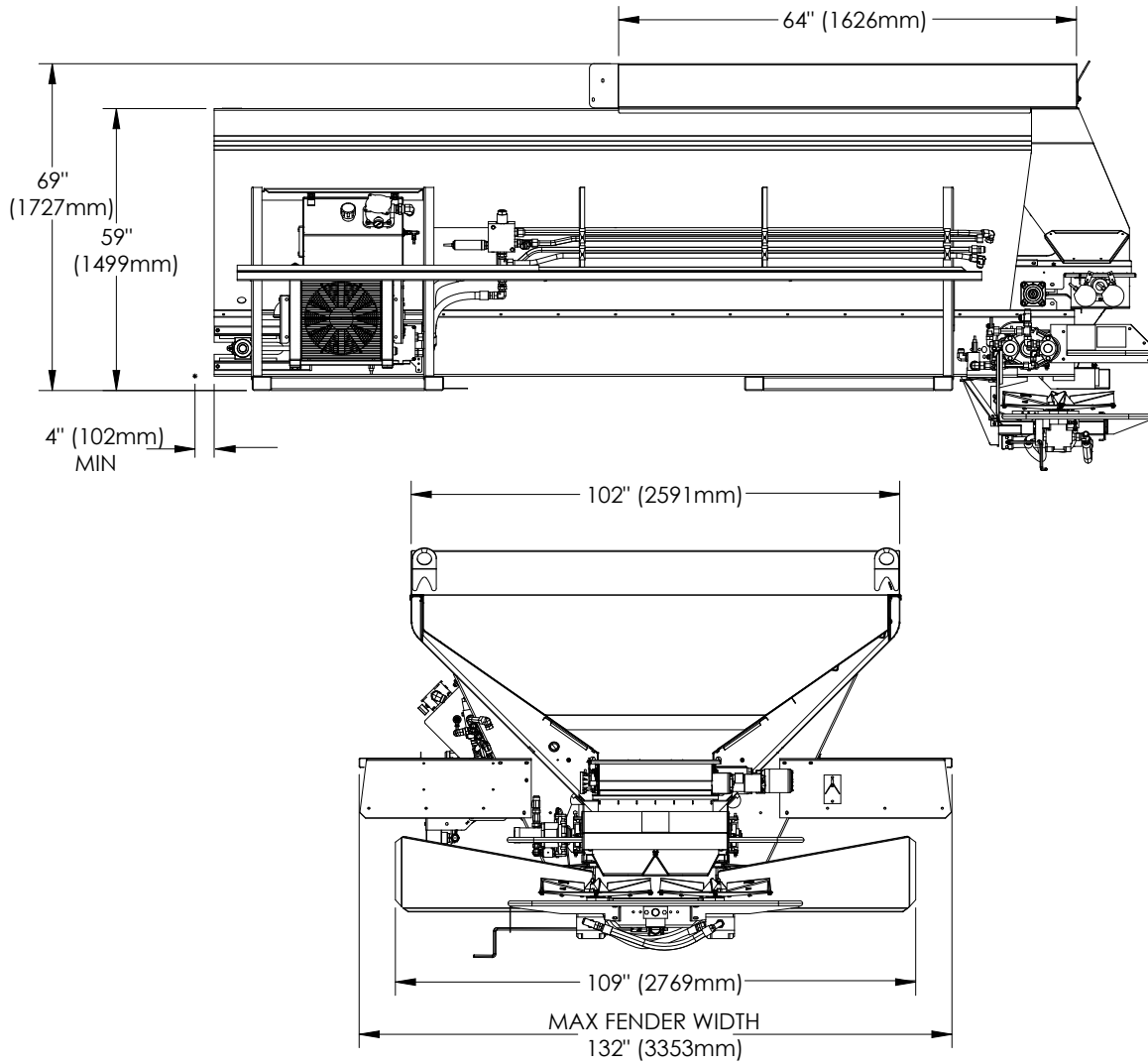

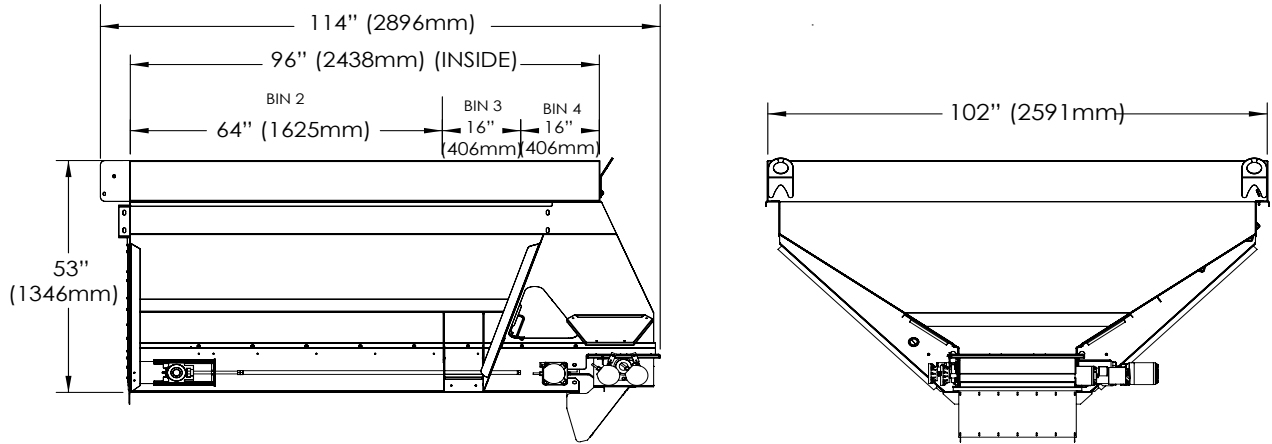

L4000G4 WITH MULTIBIN DIMENSIONS & CAPACITIES

Unit Length	Approximate Weight Lbs (Kg)	Struck Capacity * Cu Ft (Cu M)
13' (3.96m)	5000 (2273)	168 (4.76)
14' (4.27m)	5300 (2410)	197 (5.58)

MULTIBIN ALONE DIMENSIONS & CAPACITIES

	Inside Length	Approximate Weight Lbs (Kg)	Struck Capacity Cu Ft (Cu M)
MultiBin	96" (2438mm)	1700 (773)	
MultiBin (Bin 2)	64" (1626mm)		139 (3.94)
Single Micro (Bin 3)	32" (813mm)		44 (1.24)
Dual Micro (Bin 3)	16" (406mm)		23 (.65)
Dual Micro (Bin 4)	16" (406mm)		21 (.59)

* Struck Capacity Includes Sideboards

Initial Startup

⚠ WARNING

Stand clear of moving machinery. Failure to comply with this requirement could result in death or serious injury.

NOTE: Do not load spreader with material.

1. Check entire unit to make sure all fasteners are in place and properly tightened per "Standard Torques" in this manual.
2. Make sure no other persons are in vicinity of spreader.
3. Make sure no loose parts are in unit or on conveyor or spinner.
4. Check oil level in hydraulic reservoir; fill as necessary. Refer to "Lubricant & Hydraulic Oil Specifications" in this manual for proper oil. Completely open reservoir valves.
5. Start engine and turn on hydraulics. Allow hydraulics to circulate until oil is warm.
6. Run spinner only at 300RPM. Allow to run until spinner is operating smoothly and all air has been purged from system.
7. Run conveyor at 20RPM and spinner at 300RPM. Run until conveyor is operating smoothly.
8. Run conveyor at 20RPM and spinner at 700RPM. Allow both conveyor and spinner to run until operating smoothly.
9. Run conveyor at 0RPM and spinner at 0RPM. Make sure both conveyor and spinner do not move.
10. Calibrate spreader as defined in the manual for the controller that is supplied with your machine.
11. Complete spread pattern test per "Spread Pattern Testing Procedures" in this manual.
12. Shut system down.

⚠ WARNING

DO NOT check leaks with hands while system is operating as high pressure oil leaks can be dangerous! If skin is pierced with hydraulic fluid at high pressure seek immediate medical attention as fluid injected into the skin could cause gangrene if left untreated. Relieve pressure before disconnecting hydraulic lines or working system. Make sure all hydraulic fluid connections are tight and all hydraulic hoses and lines are in good condition before applying pressure to the system. Wear protective gloves and safety glasses or goggles when working with hydraulic systems. Failure to comply with this requirement could result in death or serious injury.

⚠ WARNING

DO NOT check for leaks adjacent to moving parts while system is operating as there may be danger of entanglement! Failure to comply with this requirement could result in death or serious injury.

13. Check all connections in hydraulic system to make sure there are no leaks.
14. Check hydraulic oil reservoir and refill to maintain level at mid-point of gauge.

G4 Spinner Squaring

The squareness of the G4 Spinner Assembly and supporting parts plays a critical role in obtaining acceptable spread patterns. It is highly recommended that measurements are checked before spreading with a new unit, and any time after service or repair work has been performed on any part affecting spread patterns.

1. Figure 1 - Begin by ensuring that the Spinner Assembly is mounted correctly. The Spinner Frame should be sitting on top of/inside the Sill flanges, NOT hanging below.

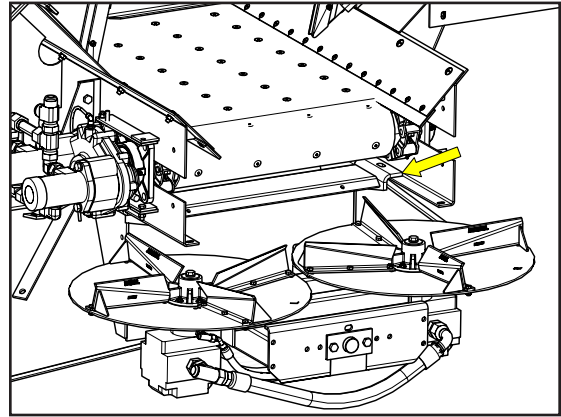

Figure 1

2. Figure 2 - Measure from the Spinner Frame mounting flange to the end of the Sill on each side. Measurement should be 9-7/8" (25cm). Measurements must be equal, or no greater than 1/8" (0.3cm) off overall.

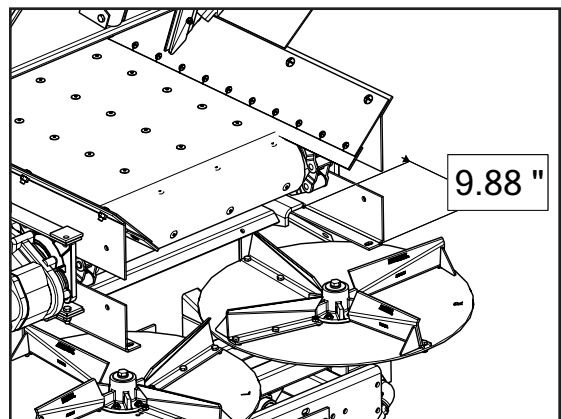

Figure 2

3. Figure 3A - 3B - Check Spinner Assembly squareness by measuring from top edge of left hand Sill to inner hex flat on right hand Spinner Hub bolt. Repeat for opposite side.

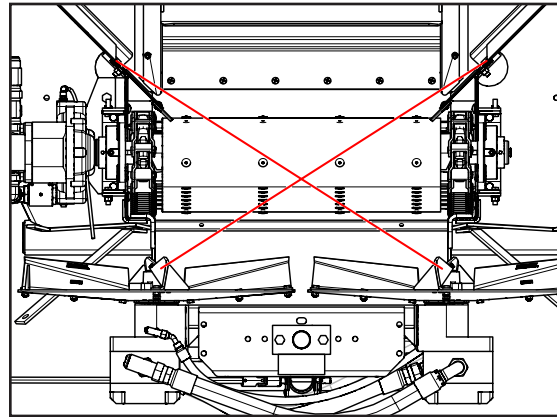

Figure 3A

4. Measurements must be equal, or no greater than 1/8" off overall.

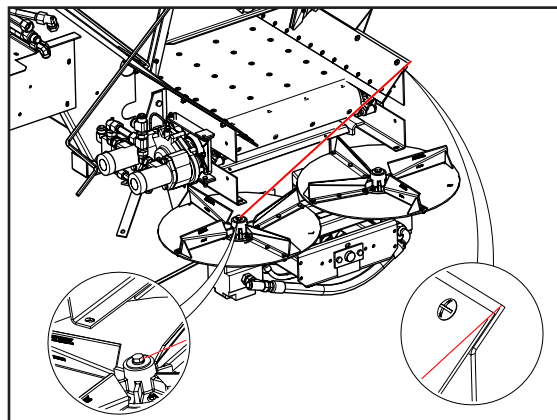

Figure 3B

5. Figure 4 - If adjustments are necessary, loosen the four 1/2" carriage bolts and adjust assembly as necessary. Once corrected, tighten hardware to recommended torque. See "Standard Torques" for details.

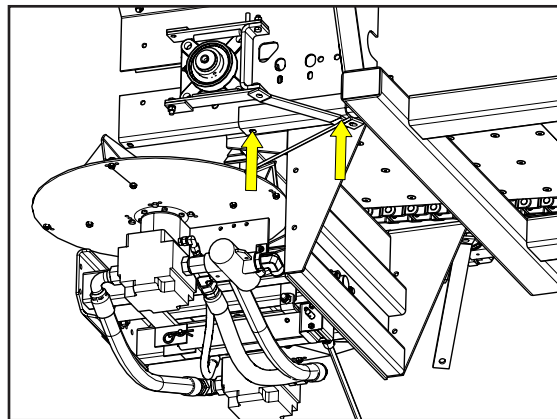

Figure 4

6. Figure 5 - Center Material Divider by measuring from the right hand inner drop-off point to the inner hex flat on the right hand Spinner Hub Bolt. Repeat measurement on opposite side. Measurements must be equal, or no greater than 1/8" off overall.

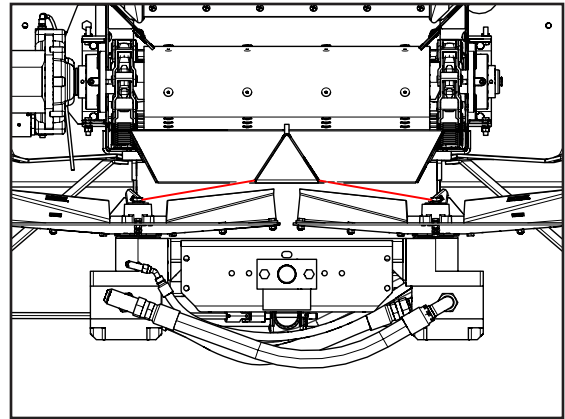

Figure 5

7. Figure 6 - Measure on each side from Spinner Frame back plate to forward drop-off point on Material Divider. Both measurements must be 12-1/4" (31cm) or no greater than 1/8" (0.3cm) off overall.
8. If adjustments are necessary, loosen the 3/8" capscrews on each side and adjust as necessary. Once corrected, tighten hardware to recommended torque.

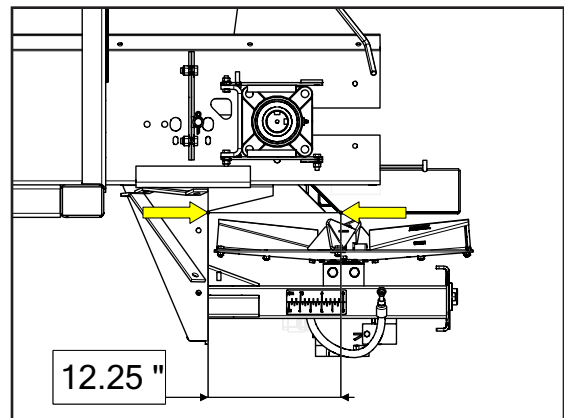

Figure 6

9. Figure 7 - If equipped, Ensure the Hillside Divider is mounted squarely and centered at both the front and the rear. Hillside Divider panel should be perpendicular to ground. Ensure the rear of the panel is centered over the center section of the Material Divider.

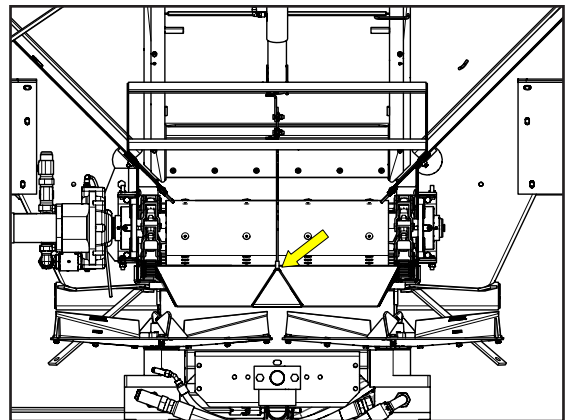

Figure 7

10. Figure 8 - Center the front of the Hillside Divider by measuring from the divider panel to the point of contact between the shield and the conveyor on each side. Measurements should be equal.

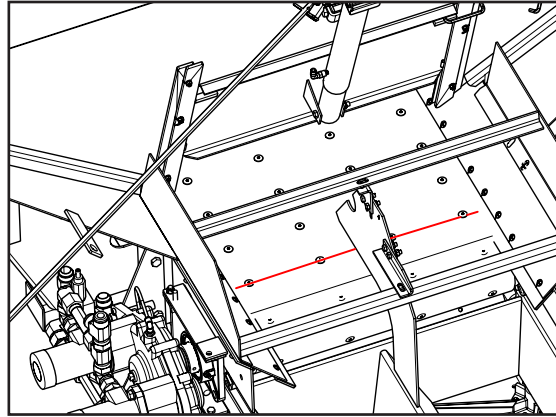

Figure 8

11. Figure 9 - Lastly, ensure that the Hillside Divider panel has proper clearance from the belt. The bottom edge of the divider panel should be approximately 3/8" (1cm) from the rubber belting of a #4 BOC.
12. If adjustments are necessary, loosen the hardware at the Hillside Divider panel as required and adjust as necessary. Once corrected, tighten hardware to proper torque.

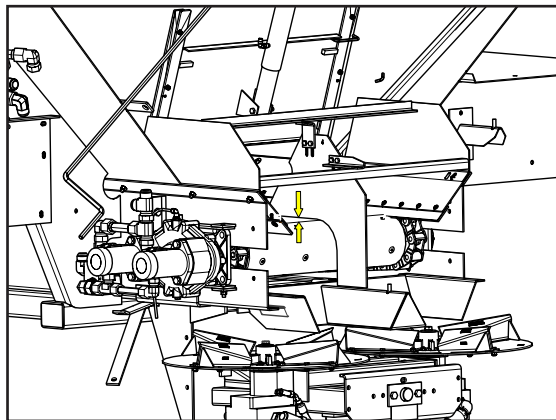

Figure 9

13. Figure 10 - Ensure all guards and shields are securely in place.
14. The spreader is now ready for field testing.

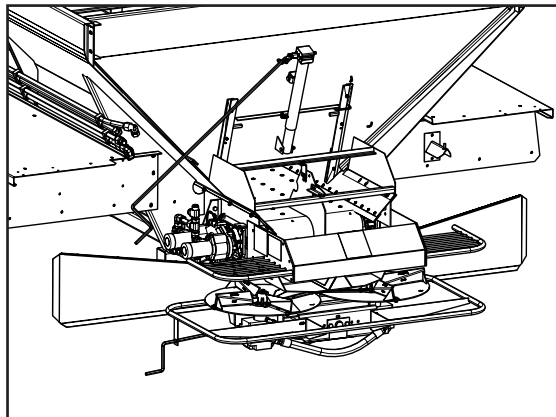

Figure 10

The following procedure is a guide:

NOTE: Do NOT fill spreader with material

1. Field test over any suitable course which allows vehicle to be driven at speeds to be used while spreading.
2. Ensure unit has been properly serviced, that the hydraulic reservoir is full and gate valve under reservoir is fully open. Do not load spreader.
3. Run spinners at 500 RPM.



! DANGER

Take proper safety precautions when observing conveyor and spinner speed while vehicle is in motion! These may include use of suitable mirrors clamped to permit observation by a safely seated observer, following the spreader in another vehicle at a safe distance, or other suitable means. Do not stand on fenders, in body or on any part of spreader as there is danger of falling off the vehicle or into moving parts! Use great care in performing this test! Failure to comply with this requirement will result in death or serious injury.

4. Start engine. Turn control to "on" position. Engage PTO and allow to run at fast idle long enough to bring hydraulic oil up to operating temperature. Spinners should revolve at moderate speed and the conveyor should not move.
5. Refer to controller's operation manual for conveyor operating instructions. Set program to operational mode and begin forward travel. Move conveyor switch to "on" position. Conveyor should start immediately when vehicle moves and should continue to run at speeds which should vary directly with the vehicle's ground speed; the conveyor should speed up as vehicle speed increases and slow down as vehicle speed reduces. Spinner speed should remain constant when engine speed is above minimum operating range.

General Operating Procedures

1. Make sure unit has been properly serviced and is in good operating condition. It is highly recommended to run the spreader prior to loading material to ensure acceptable operation.
2. Program controller with correct data for material(s) and application.
3. Adjust feedgate to appropriate setting.
4. Adjust spinner to give spread pattern desired. Calibrate and spread pattern test for any new material.
5. Fill applicable bins with material to be spread.
6. Engage hydraulics.
7. Begin spreading.

⚠ CAUTION

Drive only at speeds which permit secure control of vehicle.

NOTICE

CHANGE HYDRAULIC OIL FILTER AFTER FIRST WEEK (OR NOT MORE THAN 50 HOURS) OF OPERATION ON A UNIT.

*Visit www.newleadervip.com for interactive tools to calculate yield, proper feedgate opening, conveyor revolutions per minute and mph to maximize the performance of your spreader.

MAINTENANCE

MAINTENANCE

Maintenance

Lubrication and Maintenance

Preventative Maintenance Pays!

The handling and spreading of commercial fertilizers is a most severe operation with respect to metal corrosion. Establish a frequent, periodic preventative maintenance program to prevent rapid damage to spreading equipment. Proper cleaning, lubrication and maintenance will give you longer life, more satisfactory service and more economical use of your equipment.

⚠ WARNING

Shut off all power and allow all moving parts to come to rest before performing any maintenance operation. Failure to comply with this requirement could result in death or serious injury.

Hydraulic System

Proper oil in the hydraulic system is one of the most important factors for satisfactory operation. Utmost cleanliness in handling the oil cannot be stressed enough. Keep hydraulic oil in original closed containers, clean top of container before opening and pouring, and handle in extremely clean measures and funnels.

Refer to "Lubrication & Hydraulic Oil Specifications" on page <?> for selection of the proper hydraulic fluid for use in the hydraulic system.

Service Schedule

⚠ WARNING

DO NOT check leaks with hands while system is operating as high pressure oil leaks can be dangerous! If skin is pierced with hydraulic fluid at high pressure seek immediate medical attention as fluid injected into the skin could cause gangrene if left untreated. Relieve pressure before disconnecting hydraulic lines or working system. Make sure all hydraulic fluid connections are tight and all hydraulic hoses and lines are in good condition before applying pressure to the system. Wear protective gloves and safety glasses or goggles when working with hydraulic systems. Failure to comply with this requirement could result in death or serious injury.

⚠ WARNING

DO NOT check for leaks adjacent to moving parts while system is operating as there may be danger of entanglement! Failure to comply with this requirement could result in death or serious injury.

Check hydraulic oil daily by means of sight gauge on hydraulic tank. Add oil as necessary to maintain level around mid-point of sight gauge. Periodically inspect hoses and fittings for leaks.

NOTICE

Change hydraulic oil filter after first week (or not more than 50 hours) of operation on a unit.

Controller will warn when filter is restricted. Change filter when warning sounds.

Drain hydraulic tank through drain plug (not through suction outlet), flush, and refill and change filter element annually. Oil and filter should also be changed whenever oil shows any signs of breaking down under continued high-pressure operation. Discoloration of oil is one sign of breakdown.

Conveyor Gearcase

Drain oil in a new unit after first two weeks (or not more than 100 hours) of operation, and flush gear case thoroughly with light oil. Refer to "Lubricant and Hydraulic Oil Specifications" section for proper grade oil and recommended amounts of lubricant. After initial change, oil should be changed every 2,000 hours of operation or annually, whichever occurs first. Check gearcase oil level monthly.

Check gearcase oil level monthly.

Hydraulic Hose

Hose assemblies in operation should be inspected frequently for leakage, kinking, abrasion, corrosion or other signs of wear or damage. Worn or damaged hose assemblies should be replaced immediately.

⚠ WARNING

Testing should be conducted in approved test stands with adequate guards to protect the operator. Failure to comply with this requirement could result in death or serious injury.

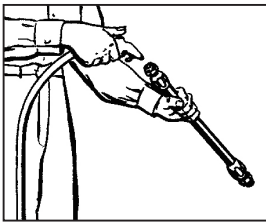

Clean

Clean assembly by blowing out with clean compressed air. Assemblies may be rinsed out with mineral spirits if the tube stock is compatible with oil, otherwise hot water at 150°F (65.55° C) maximum may be used.



Inspect

Examine hose assembly internally for cut or bulged tube, obstructions, and cleanliness. For segment style fittings, be sure that the hose butts up against the nipple shoulder; band and retaining ring are properly set and tight, and segments are properly spaced. Check for proper gap between nut and socket or hex and socket. Nuts should swivel freely. Check the layline of the hose to be sure the assembly is not twisted. Cap the ends of the hose with plastic covers to keep clean.

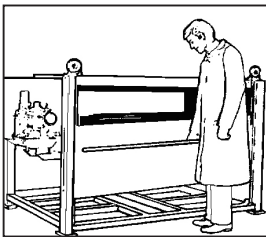

Test

The hose assembly should be hydrostatically tested at twice the recommended working pressure of the hose.

Test pressure should be held for not more than one minute and not less than 30 seconds. When test pressure is reached, visually inspect hose assembly for: 1. Any leaks or signs of weakness. 2. Any movement of the hose fitting in relation to the hose. Any of these defects are cause for rejection.

Storage and Handling

Hose should be stored in a dark, dry atmosphere away from electrical equipment, and the temperature should not exceed 90° F (32° C).

Conveyor Chain

⚠ WARNING

Stay out of the spreader. If it's necessary to enter the spreader, return to the shop, empty body, turn off all power, set vehicle brakes, lock engine starting switch and remove keys before entering. Tag all controls to prohibit operation. Tags should be placed, and later removed, only by person working in the body. Failure to comply with this requirement could result in death or serious injury.

Hose down unit and remove any material build-up on sprockets and under chain.

NOTICE

The conveyor will move away from the bottom panel if material accumulates under the conveyor or on the sprockets. The more material that accumulates, the closer the chain will come to the chain shields. If the conveyor should catch a chain shield, it could permanently damage the conveyor, the chain shields or the unit. Do not remove material while conveyor or spinner is running!

Lubrication

Make sure unit is clean and completely dry. Lubricate conveyor chain at the end of each day of usage using a mixture of 75% diesel fuel and 25% SAE 10 oil. Shut down spinner and run conveyor at 20 RPM for two full revolutions to lubricate chain. After each unit washing, allow to dry, then lubricate.

Lubricate MULTAPPLIER/MULTIBIN conveyor chain bi-weekly and at end of each season with Fluid Film™ or equivalent. Shut down spinner and run conveyor at 20 RPM. Lubricate chain through two full revolutions. After each unit washing, allow to dry, then lubricate.

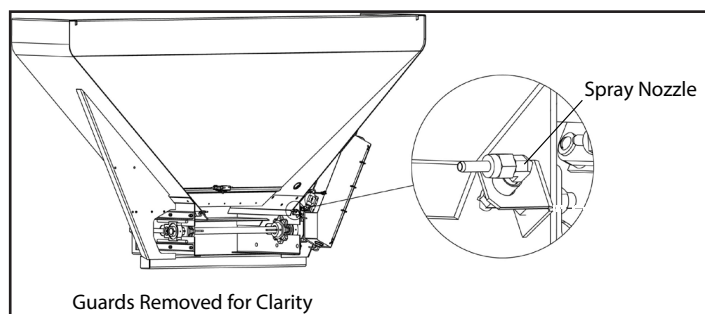

Figure 1 - Spray Nozzle

Before filling the unit with spreading material, activate the controller or power switch to run the pump oiler. Bleed all air from the lines and adjust the two spray nozzles so that the oil mixture sprays vertical onto the sprockets and chain.

Tension

Proper chain tension is also a factor in chain and sprocket life. Measure from rear of main unit forward to achieve proper chain tension (Figure 2). Make sure chain is tensioned equally on both sides. This adjustment is made on each side of the unit at the front idler bearings.

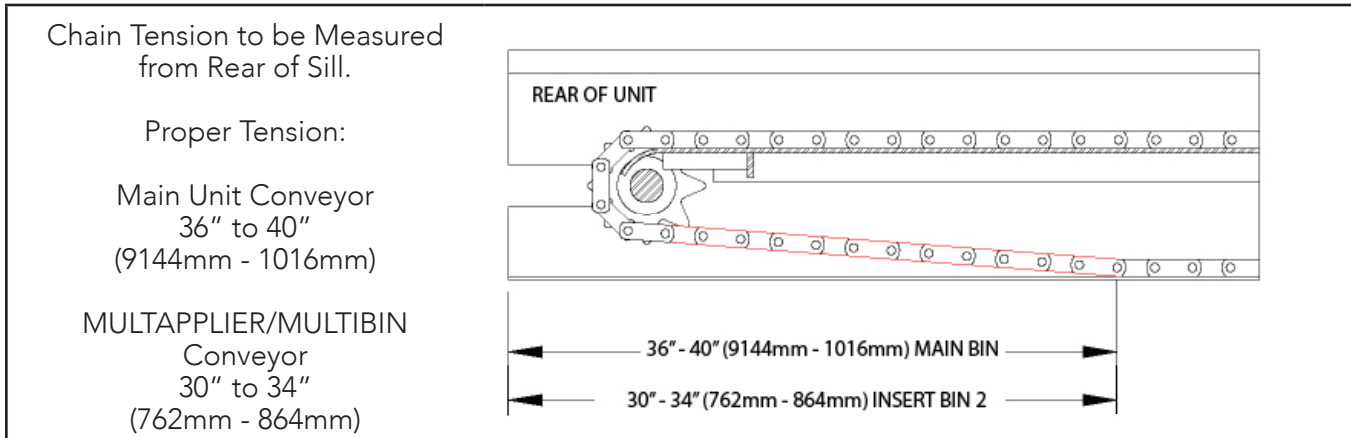

Figure 2 - Chain Tension

Conveyor chains that are too tight will tend to stretch, causing excess sprocket wear and eventually breakage. Excess slack presents the possibility of chain catching on sub-frame parts. Bent or distorted chain bars will cause damage to unit as well as fertilizer leakage with #3 conveyors. Straighten or replace bent or distorted chain bars immediately.

Conveyor Belt Maintenance

Standard belt for the #4 chain is moderate oil resistant that is impervious to moisture, weathering, or normal action which can be used with chemical impregnated fertilizer or oil based additives.

- Inspect belt fastener occasionally for wear or "raveling" of belt grip area.
- Make sure belt connecting pin is positioned correctly as shown in Figure 3.

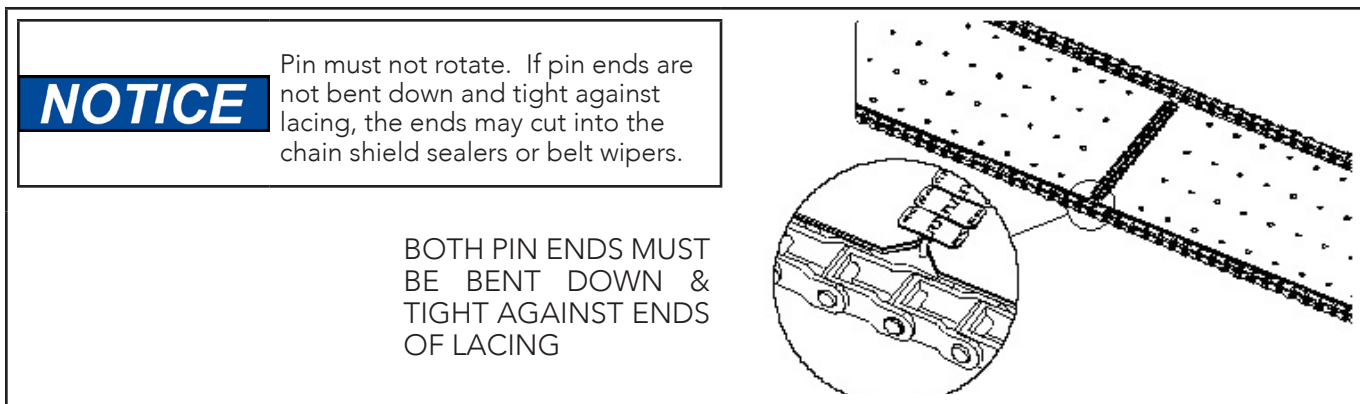

Figure 3 - Conveyor Belt Pin Installation

Bin Sensor

⚠ WARNING

Stay out of the spreader. Do not climb on spreader. Use a portable ladder to inspect, clean and maintain the bin sensor from outside the spreader. Failure to comply with this requirement could result in death or serious injury.

NOTICE

Wipe sensor clean periodically to prevent accumulation of product. Avoid wet material as it may stick to sensor. If material sticks to sensor it won't warn user when bin is low.

Clean sensor with long handled brush or hose from outside of spreader. Do not aim high pressure sprayer directly at sensor—it could damage the components.

Lubrication of Bearings

Grease in a bearing acts to prevent excessive wear of parts, protects ball races, and balls from corrosion and aids in preventing excessive heat within the bearing. It is very important the grease maintain its proper consistency during operation. It must not be fluid and it must not channel.

Make sure all fittings are thoroughly cleaned before grease is injected. Points to be lubricated by means of a grease gun have standard grease fittings.

Lubricate bearings by pumping grease slowly until it forms a slight bead around the seals. This bead indicates adequate lubrication and also provides additional protection against the entrance of dirt.

Fasteners

Tighten all screws fasteners to recommended torques after first week of operation and annually thereafter. If loose fasteners are found at anytime, tighten to recommended torque. Replace any lost or damaged fasteners or other parts immediately. Check body mounting hardware every week.

Clean-Up

NOTICE

High pressure wash can inject water and/or fertilizer into control components, causing damage. Use caution when cleaning these areas.

Thoroughly wash unit every two to three days during the operating season to maintain minimal maintenance operation. Hose unit down under pressure to free all sticky and frozen material.

It is important the unit be thoroughly cleaned at the end of each operating season. All lubrication and maintenance instructions should be closely followed. Repaint worn spots to prevent formation of rust.

MULTIBIN Meter Wheel(s): Pull inspection plug on right hand side of micro assembly. Blow out with compressed air.

Spinner Fins

Visually inspect spinner fins daily for build-up of material and wear. Spinner discs and fins must be kept clean and polished. Even a small build-up of material on a spinner can significantly affect the spread pattern. Rough, bent or worn fins will produce poor spread patterns. Replace worn fins and discs as needed. See Fin Kit Installation Instructions for replacement part numbers and instructions.

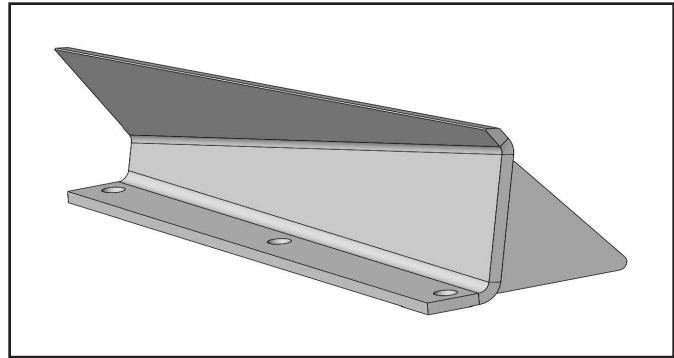

Figure 4 - Spinner Fin

Spinner Deflectors

Visually inspect spinner deflectors daily for build-up of material and damage. Clean as needed. Even a small build-up of material on a spinner deflector can affect the spread pattern. If damaged, bent or otherwise, replace. See parts manual for replacement part numbers.

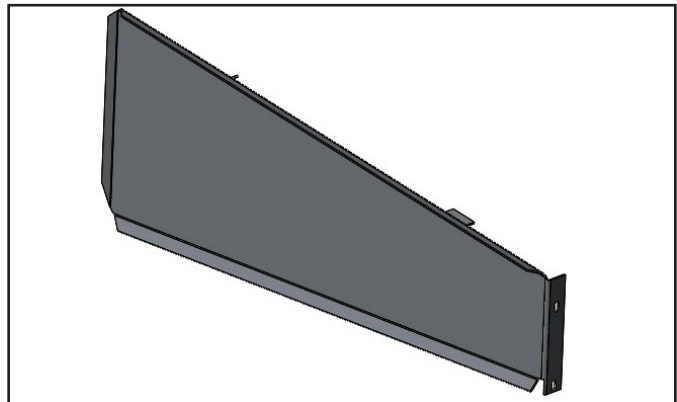

Figure 5 - Spinner Deflector

Material & Hillside Flow Dividers

Visually inspect material divider and hillside flow dividers (as equipped) daily for build-up of material and wear. Any build-up of material on divider components can affect performance. Clean as needed. Replace worn or damaged parts as necessary. See parts manual for replacement part numbers.

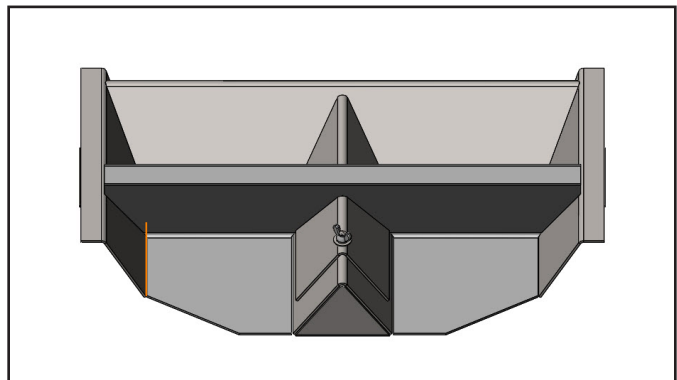

Figure 6 - Material Divider

Hydraulic System

Use premium quality lubricants with 100-200 SUS or 20-43 cSt viscosity at operating temperatures. The hydraulic fluid's specifications in the table below are for normal operating conditions. Extreme environments or dirty conditions may require the use of different oils. Consult your New Leader dealer or the Product Support Department at Highway Equipment Company for systems operating outside normal conditions.

Ideal Oil Operating Temperature	115-158°F (46.11-70° C)
Recommended Premium Lubricant	Multi-Purpose Agriculture Hydraulic & Transmission Oil
Lubricant Specifications Viscosity Index Viscosity at 40°C, cst Viscosity at 100°C, cst	Greater than 130 Less than 68 Greater than 9
Acceptable Fluid Example	Mobil 424

Gearcase Lubricant

Lubricate these assemblies with non-corrosive type extreme pressure (E.P.) gear oil conforming to MIL-L2105 B multi-purpose gear lubricating oil requirements (API Service GL 4) based on ambient temperatures listed below. Refill gear case with one and a half (1-1/2) pints (.70 liters) of recommended lubricant.

Ambient Temperature	Below 40° (4.44° C)	Between 40° (4.44° C) and 100° (37.77° C)	Above 100° (37.77° C)
Oil Type	SAE 80 E.P.	SAE 90 E.P.	SAE 140 E.P.

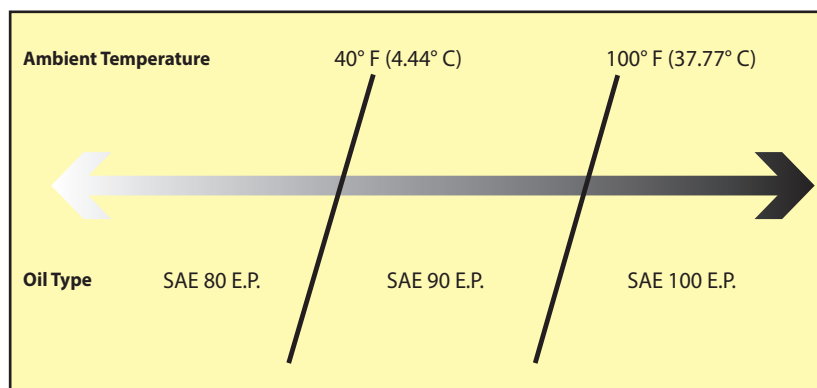

Grease Gun Lubricant

Use a waterproof ball and roller bearing lithium base lubricant with a minimum melting point of 300°F (148.8° C). This lubricant should have a viscosity which assures easy handling in the pressure gun at prevailing atmospheric temperatures. The grease should conform to NLGI No. 2 consistency.

Chain Conveyors

Use a mixture of 75% No. 1 or No. 2 diesel fuel or kerosene mixed with 25% SAE 10 engine oil in the main unit conveyor chain oiler.

Spray MULTAPPLIER/MULTIBIN conveyor chain with Fluid Film™ spray lubricant or equivalent.

⚠ WARNING	Shut off all power and allow all moving parts to come to rest before performing any maintenance operation. Failure to comply with this warning could result in death or serious injury.
------------------	---

The spreader should be regularly lubricated with the lubricants recommended in this manual in accordance with the following chart:

Location	Places	Method	Frequency
Hydraulic System			
Reservoir	1		Check Daily. Change Annually
Filter	1	Check daily; Change when indicated (Red)	
Conveyor			
Dragshaft Bearings (A)	2	Grease Gun	Weekly
Idler Shaft Bearings (B)	2	Grease Gun	Weekly
Take-Up Screws (C)	2	Hand Grease	Weekly
Snubber Pulley Bearings (D)	2	Grease Gun	Weekly
Gearcase	1	Gear Oil	Check Monthly; Change Annually
Feedgate			
Jack Assembly (E)	1	Grease Gun	Annually
Spinner Assembly			
Jack Assembly (F)	1	Grease Gun	Weekly
Bin 2 Conveyor			
Dragshaft Bearings (G)	2	Grease Gun	Weekly
Idler Shaft Bearings (H)	2	Grease Gun	Weekly
Take-Up Screws (J)	2	Hand Grease	Annually
Conveyor Chain Strands	2	Oil Mixture	Bi-Weekly
		Spray Lubricant	Annually

NOTE: Unusual conditions, such as excessive dust, temperature extremes or excessive moisture may require more frequent lubrication of specific parts.

*See "Lubricant and Hydraulic Oil Specifications" for types of lubricants and oil to be used.

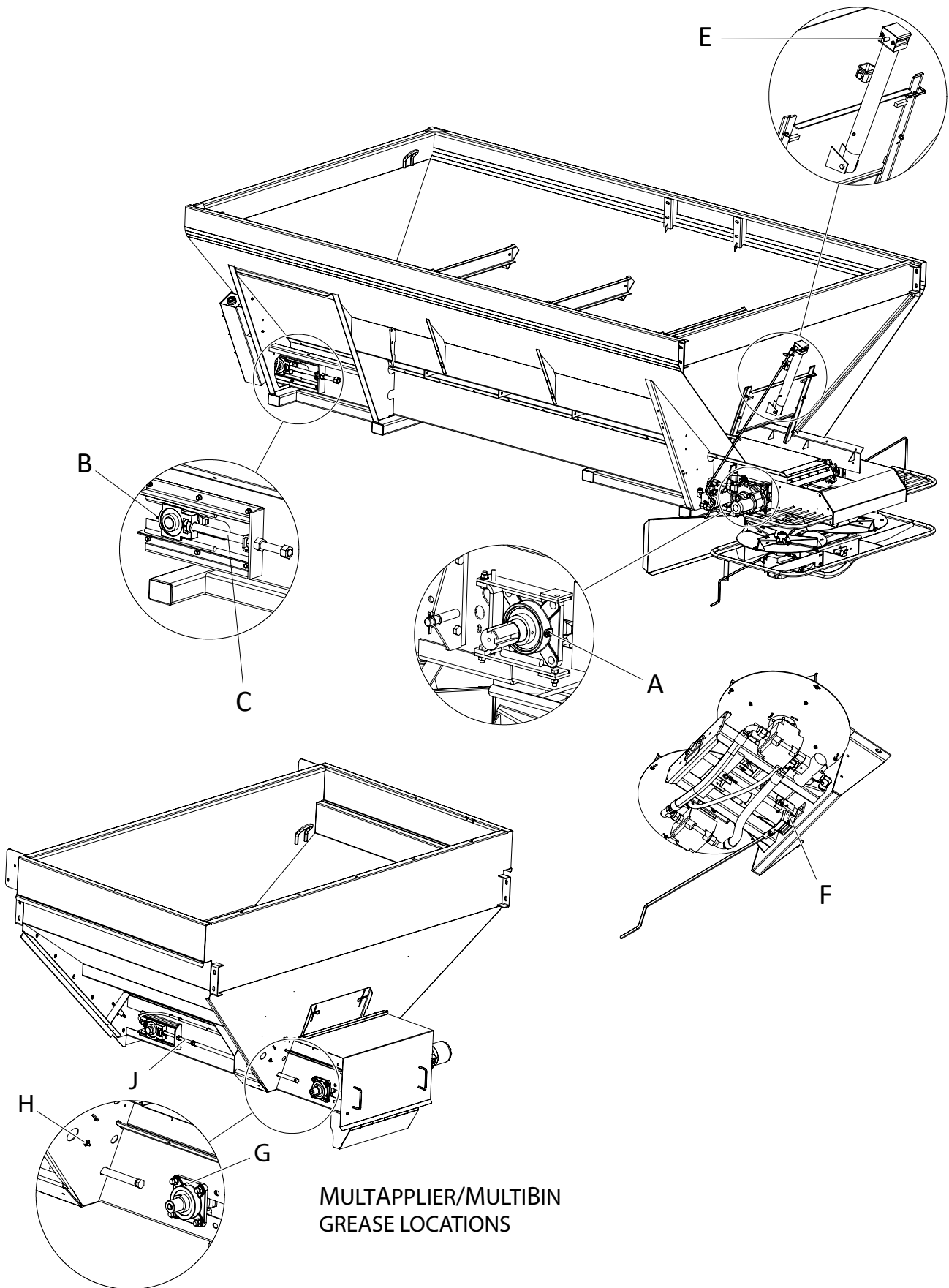

Symptom:	Reason:	Correction:
Spinner will not run	Defective Spinner Control Valve	Replace spinner control valve cartridge and coil.
	No voltage at valve	Verify spinner switch is on.
		Verify spinner enable is checked.
		Verify controller has a target spinner RPM entered.
		Check WSM 7.5 amp fuse is not blown.
		Verify spinner control harness is not damaged.
	Verify system was configured as Basic independent.	
	No hydraulic flow	Verify hydraulics are on.
Pressure test pump - replace as needed.		
System is going over relief - test & replace as needed.		
Spinner will not shut off	Defective spinner control valve	Replace spinner control valve cartridge.
	Control valve is manually override	Loosen jam nut on control valve cartridge and back set screw out until spinner stops.
Spinner runs erratic	Defective spinner control valve	Replace spinner control valve cartridge.
	Spinner speed sensor harness failure	Replace sensor harness.
	Spinner speed sensor not properly installed	Adjust sensor so that gap between sensor and fin mounting bolt is less than 1/8".
Spinner speed drops off when turning around	Improper control settings	Verify PWM control is set properly (HOLD for gear pumps, CONTROL for variable displacement).
Not applying correct rate	Incorrect settings	Verify density, swath width, gate opening, encoder pulses, and CFR number are all adjusted as needed.
No ground speed	Manual speed is enabled, but set to 0	Enter correct speed or disable manual speed
	AUX broadcast speed is enabled but radar not installed	Disable broadcast AUX speed.
	Incorrect speed source is selected	Select correct speed source.
Spinner speed does not hit target	Defective spinner control valve	Replace spinner control valve cartridge.
	Pump failure	Flow and pressure test pump.
	Spinner speed sensor not properly installed	Adjust sensor so that gap between sensor and fin mounting bolt is less than 1/8".
	Hydraulic flow dropping off	Adjust settings and speed. Pressure test relief (adjust or replace as needed).
	Spinner speed sensor harness failure	Replace sensor harness.
	Spinner speed sensor failure	Replace spinner speed sensor.

Symptom:	Reason:	Correction:
Conveyor will not run	Defective conveyor control valve	Replace conveyor valve cartridge.
	No voltage at valve	Verify bin switch and master switches on.
		Verify in controller that target rate, density, ground speed and a CFR number are all entered.
		Check WSM 7.5 amp fuse is not blown.
		Verify conveyor control harness is not damaged.
	No hydraulic flow	Verify hydraulics are on.
		Pressure test pump - replace as needed.
		System is going over relief - test & replace as needed.
Conveyor is going over relief - test & replace as needed.		
Conveyor will not shut off	Defective conveyor cartridge	Replace conveyor control valve cartridge.
	Control valve is out of time	Adjust cartridge timing.
Conveyor runs erratic	Defective conveyor cartridge	Replace conveyor control valve cartridge.
	Encoder failure	Replace encoder.
	Encoder harness failure	Replace harness.
	Rates smooting is disabled	Enable rate smoothing.
Bin will not hit target rate	Defective conveyor cartridge	Replace conveyor control valve cartridge.
	Pump failure	Flow and pressure test pump.
	Going over relief	Adjust setting and speed. Pressure test relief (adjust or replace as needed).
	Encoder failure	Replace encoder.
	Encoder harness failure	Replace harness.
Hydraulics over-heating	Pump failure	Flow and pressure test pump.
	Too much flow	Flow test pump.
	System relief	Pressure test relief (adjust or replace as needed). Adjust settings and speed.
	Conveyor valve relief	Pressure test relief (adjust or replace as needed). Adjust settings and speed.
	Oil cooler fan failure	see oil cooler fan failures.
	Case drain is plugged.	Case drain requires zero pressure line back to tank.
Oil cooler fan failure	No power at fan	Verify FAN 30-amp fuse is not blown. Verify relay is working properly.
	Fan failure	Replace fan.
Bin level sensors not working properly	Not enabled	Verify system was configured with bin level sensors.
	Bin level sensor failure	Replace sensor.
	Bin level sensor harness failure	Replace harness.

MultiBin Cover Air Schematic

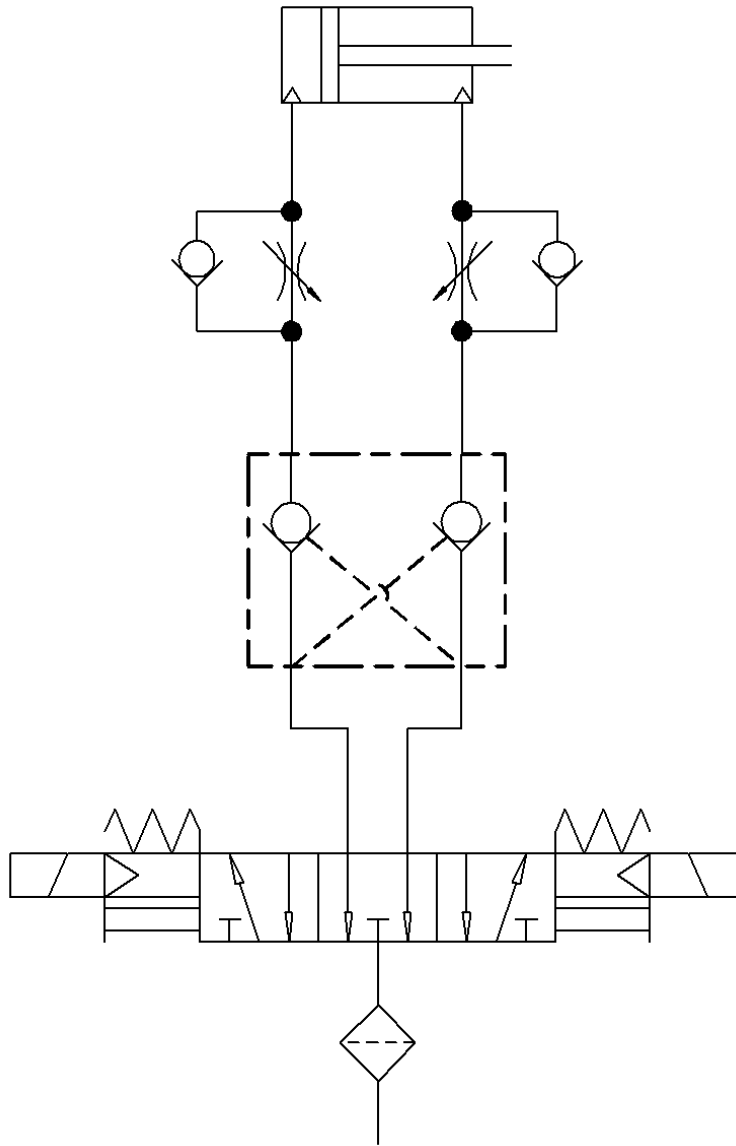

AUXILLARY SUPPLY LINE
DRY AIR
85 PSIG

CAP SCREW GRADE IDENTIFICATION - MARKINGS ON HEAD

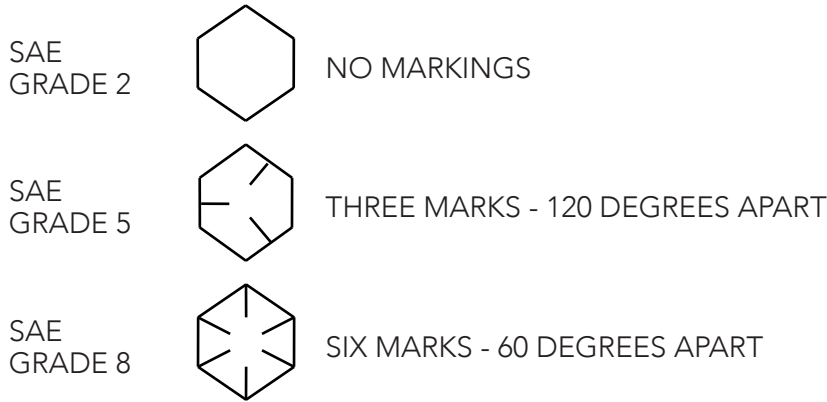

USE GRADE 2 TORQUES FOR STAINLESS STEEL FASTENERS AND CARRIAGE BOLTS.

CAP SCREW SIZE	TORQUE - FOOT-POUNDS					
	GRADE 2		GRADE 5		GRADE 8	
	DRY	LUBE	DRY	LUBE	DRY	LUBE
1/4"	5	4	8	6	12	9
5/16"	11	8	17	13	25	18
3/8"	20	15	30	23	45	35
7/16"	30	24	50	35	70	55
1/2"	50	35	75	55	110	80
9/16"	65	50	110	80	150	110
5/8"	90	70	150	110	220	170
3/4"	100	120	260	200	380	280
7/8"	140	110	400	300	600	460
1"	220	160	580	440	900	650

IMPORTANT! Do not operate or work on machine without reading and understanding the operator's manual.

Before starting engine/before starting machine operation

- | | |
|--|---|
| <input type="checkbox"/> Program rate controller and document settings | <input type="checkbox"/> Hydraulic hoses are secured properly |
| <input type="checkbox"/> All stop, tail, and turn lights function properly | <input type="checkbox"/> Gearcase oil level is correct |
| <input type="checkbox"/> Tire pressures are equal on each side of chassis | <input type="checkbox"/> Safety shields in place |
| <input type="checkbox"/> Battery condition and connection | <input type="checkbox"/> Spinner Assy moves through full range of operation |
| <input type="checkbox"/> Electrical connections are tight and secure | <input type="checkbox"/> Spinner discs and fins installed properly |
| <input type="checkbox"/> All fasteners are secure | <input type="checkbox"/> Spinner discs and fins are in acceptable condition |
| <input type="checkbox"/> Inverted "V" is secure and installed properly | <input type="checkbox"/> Material Divider assembly is square and secure |
| <input type="checkbox"/> Sensor(s) are functioning properly | <input type="checkbox"/> Material Divider is clean of build-up |
| <input type="checkbox"/> Lubricate all grease fittings | <input type="checkbox"/> Feedgate assembly is level |
| <input type="checkbox"/> Hydraulic oil level and line connections are tight | <input type="checkbox"/> Encoder installed and secured |
| <input type="checkbox"/> Hydraulic filters are current and gauge is functional | <input type="checkbox"/> Spinner sensor adjusted to proper gap |
| <input type="checkbox"/> Chain oiler tank is full and operates correctly | |

Start engine/Start and run to operational temperatures

- | | |
|--|--|
| <input type="checkbox"/> Hydraulic fittings are tight, no leaks * | <input type="checkbox"/> Conveyor control valve is operating correctly |
| <input type="checkbox"/> Check operation of all alarms | <input type="checkbox"/> Calibrate radar/ground speed input |
| <input type="checkbox"/> Hydraulic flow test: ____GPM @ operating engine RPM | <input type="checkbox"/> Test maximum conveyor(s) RPM |
| <input type="checkbox"/> Check main relief valve setting : ____ PSI | <input type="checkbox"/> Test right and left hand spinner speed; ensure difference is less than 30 RPM (when at operating RPM) |

Stop operation/Turn off engine and engage parking brake

- | | |
|---|--|
| <input type="checkbox"/> Visually check for leaks | <input type="checkbox"/> All oil levels full |
| <input type="checkbox"/> Check belt/chain tension and alignment | |

Perform Calibrations

- Product density testing, crush strength, and SGN scale (See Spread Pattern Calibration section for instructions).
- Catch tests of all products and at least 1 blend for conveyor calibration and document settings and product characteristics
- Spread pattern tests of all products and at least 1 blend and document settings and product characteristics

End of Season

- | | |
|---|---|
| <input type="checkbox"/> Empty unit of all material | <input type="checkbox"/> Clean unit inside and out |
| <input type="checkbox"/> Sand and touch-up paint as necessary | <input type="checkbox"/> Check for leaks |
| <input type="checkbox"/> Wash chain conveyor, lubricate thoroughly when dry | <input type="checkbox"/> Lubricate all grease fittings |
| <input type="checkbox"/> Check spinner discs and fins for wear | <input type="checkbox"/> Ensure all fasteners are secure and properly torqued |

HYDRAULICS

HYDRAULICS

HYDRAULIC SCHEMATICS

The following pages contain representative hydraulic schematics for all configurations of the L4000G4 model spreader.

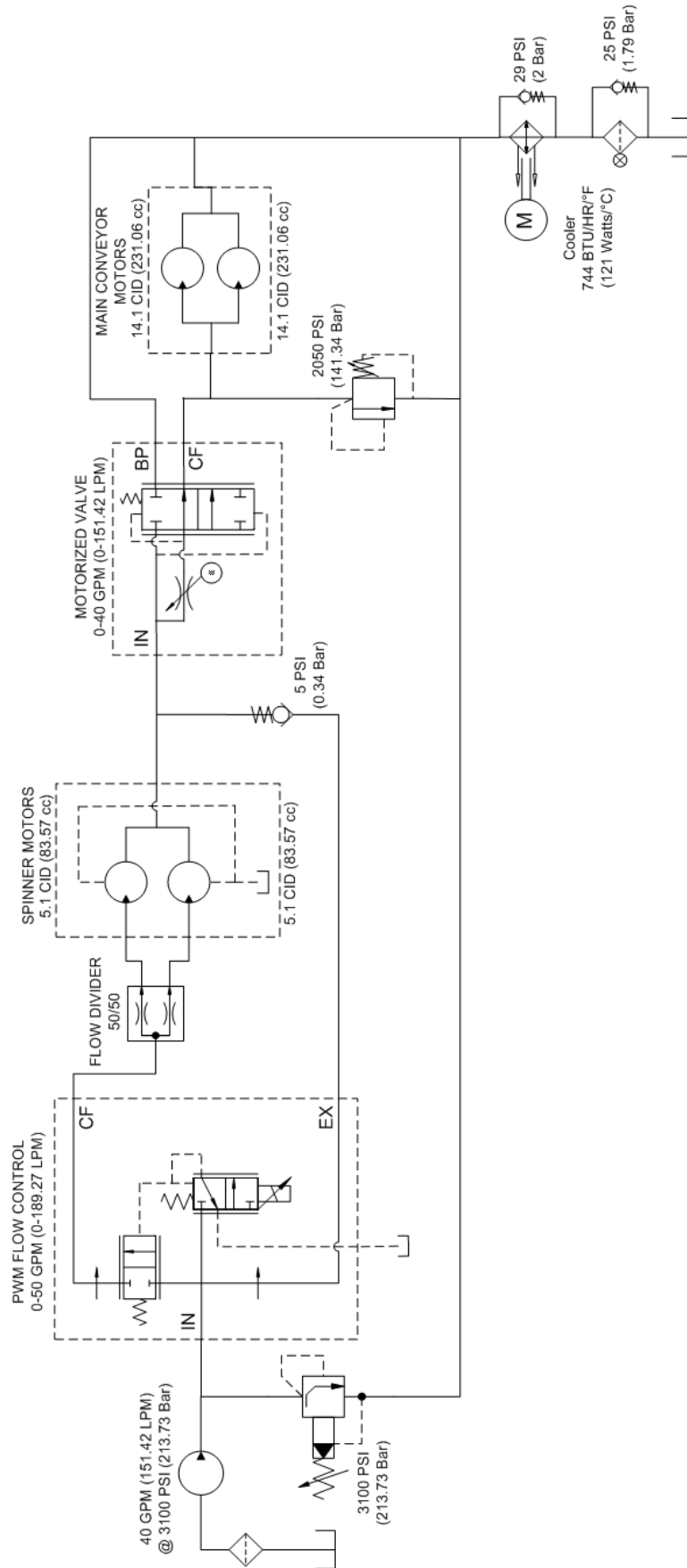

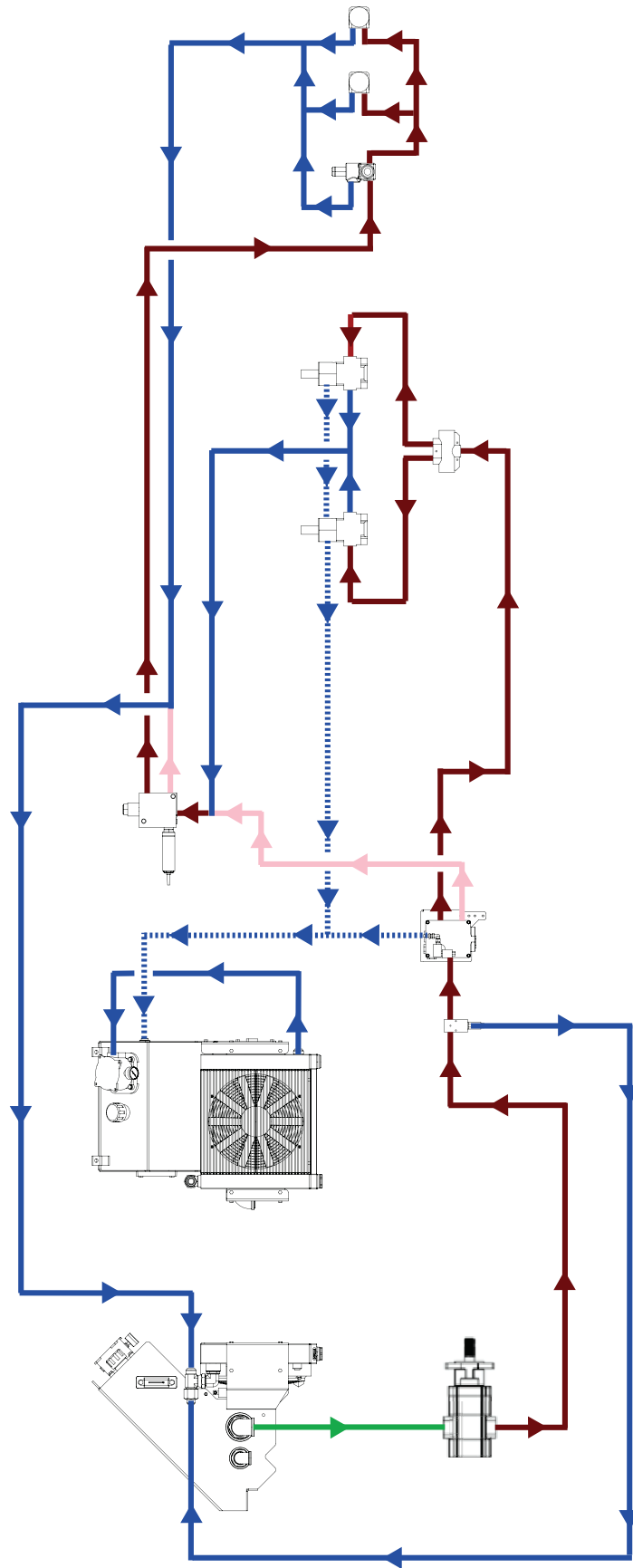

LEGEND	
	CONTROL FLOW (HIGH PRESSURE)
	EXCESS FLOW (HIGH PRESSURE)
	RETURN FLOW (LOW PRESSURE)
	CASE DRAIN (LOW PRESSURE)
	SUCTION FLOW (LOW PRESSURE)
	PRESSURE ONLY (HIGH PRESSURE)
	BI-DIRECTIONAL FLOW (HIGH PRESSURE)
	LOAD SENSE (HIGH PRESSURE)



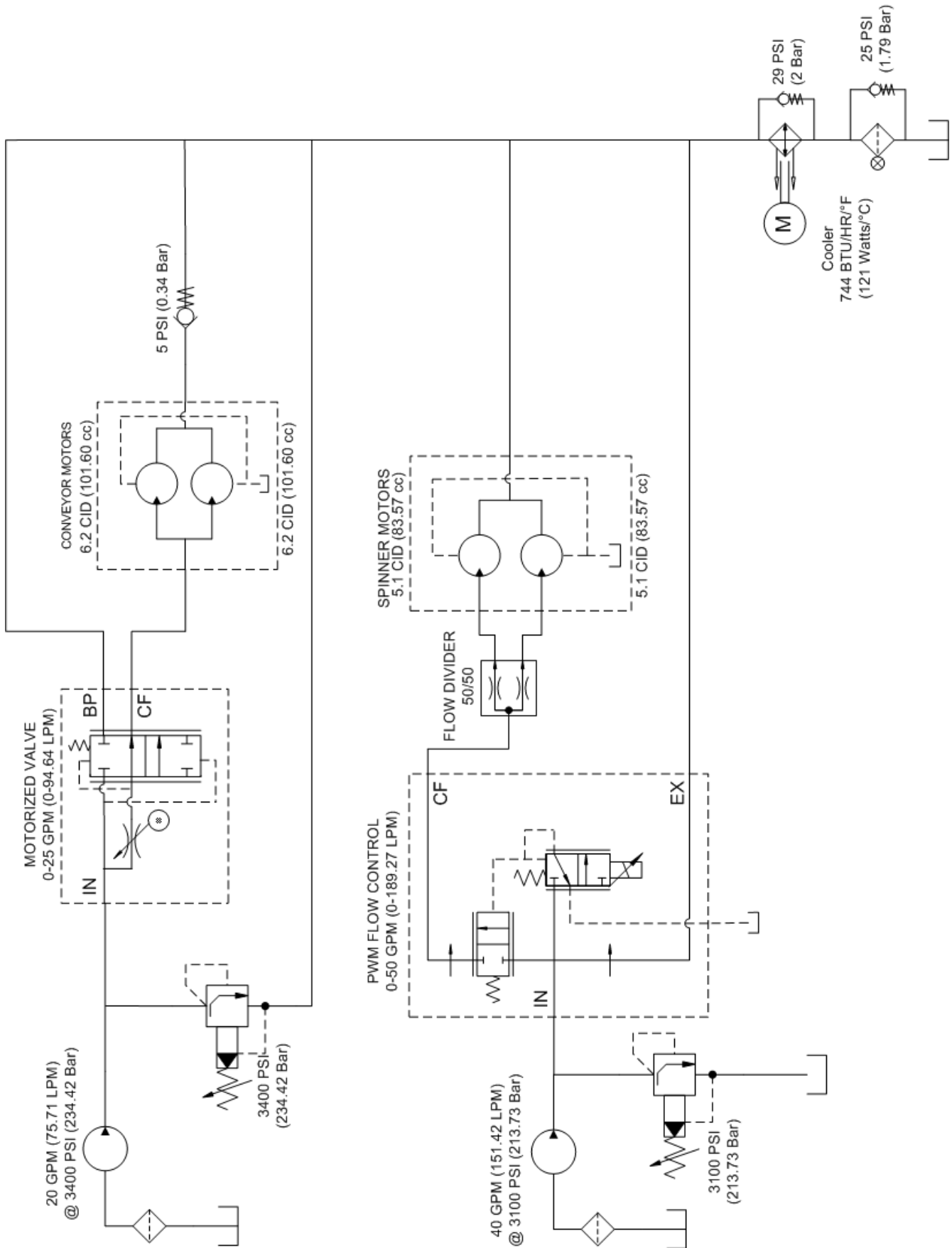

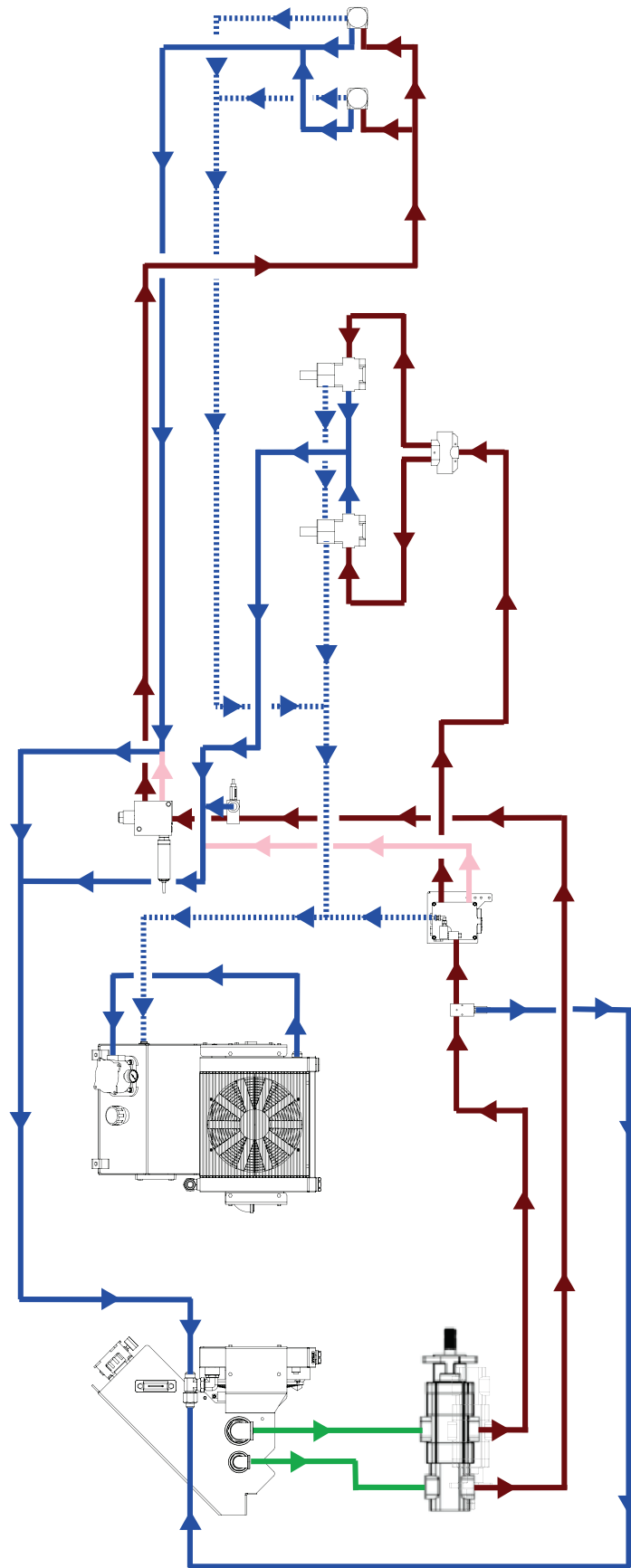

LEGEND	
(Solid Blue Line)	CONTROL FLOW (HIGH PRESSURE)
(Solid Red Line)	EXCESS FLOW (HIGH PRESSURE)
(Solid Blue Line)	RETURN FLOW (LOW PRESSURE)
(Dotted Blue Line)	CASE DRAIN (LOW PRESSURE)
(Solid Green Line)	SUCTION FLOW (LOW PRESSURE)
(Dotted Blue Line)	PRESSURE ONLY (HIGH PRESSURE)
(Dotted Red Line)	BI-DIRECTIONAL FLOW (HIGH PRESSURE)
(Dotted Red Line)	LOAD SENSE (HIGH PRESSURE)

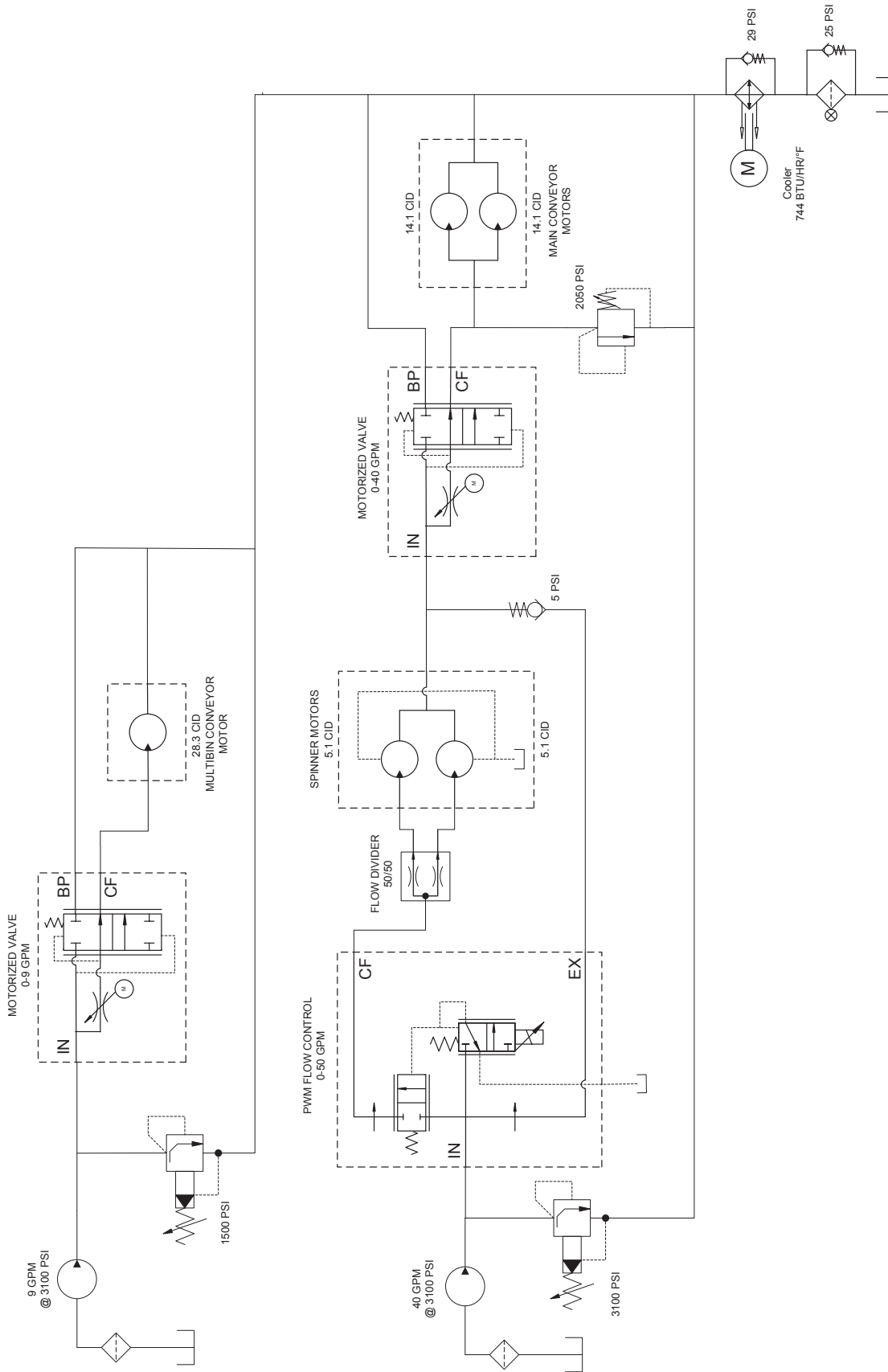

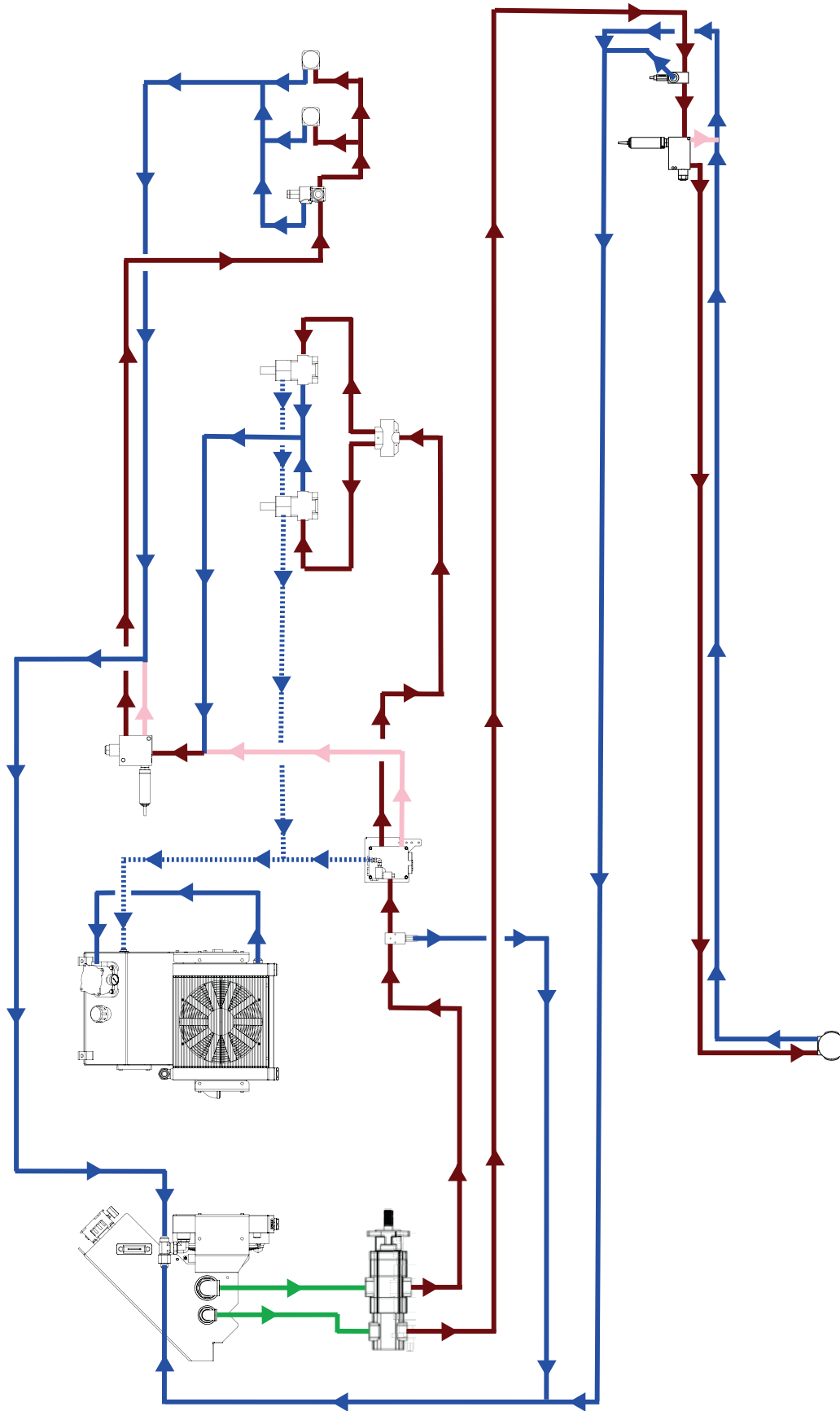

LEGEND	
(HIGH PRESSURE)	(HIGH PRESSURE)
(HIGH PRESSURE)	(LOW PRESSURE)
(LOW PRESSURE)	(LOW PRESSURE)
(LOW PRESSURE)	(LOW PRESSURE)
(HIGH PRESSURE)	(HIGH PRESSURE)
(HIGH PRESSURE)	(HIGH PRESSURE)
(HIGH PRESSURE)	(HIGH PRESSURE)

CONTROL FLOW
EXCESS FLOW
RETURN FLOW
CASE DRAIN
SUCTION FLOW
PRESSURE ONLY
BI-DIRECTIONAL FLOW
LOAD SENSE

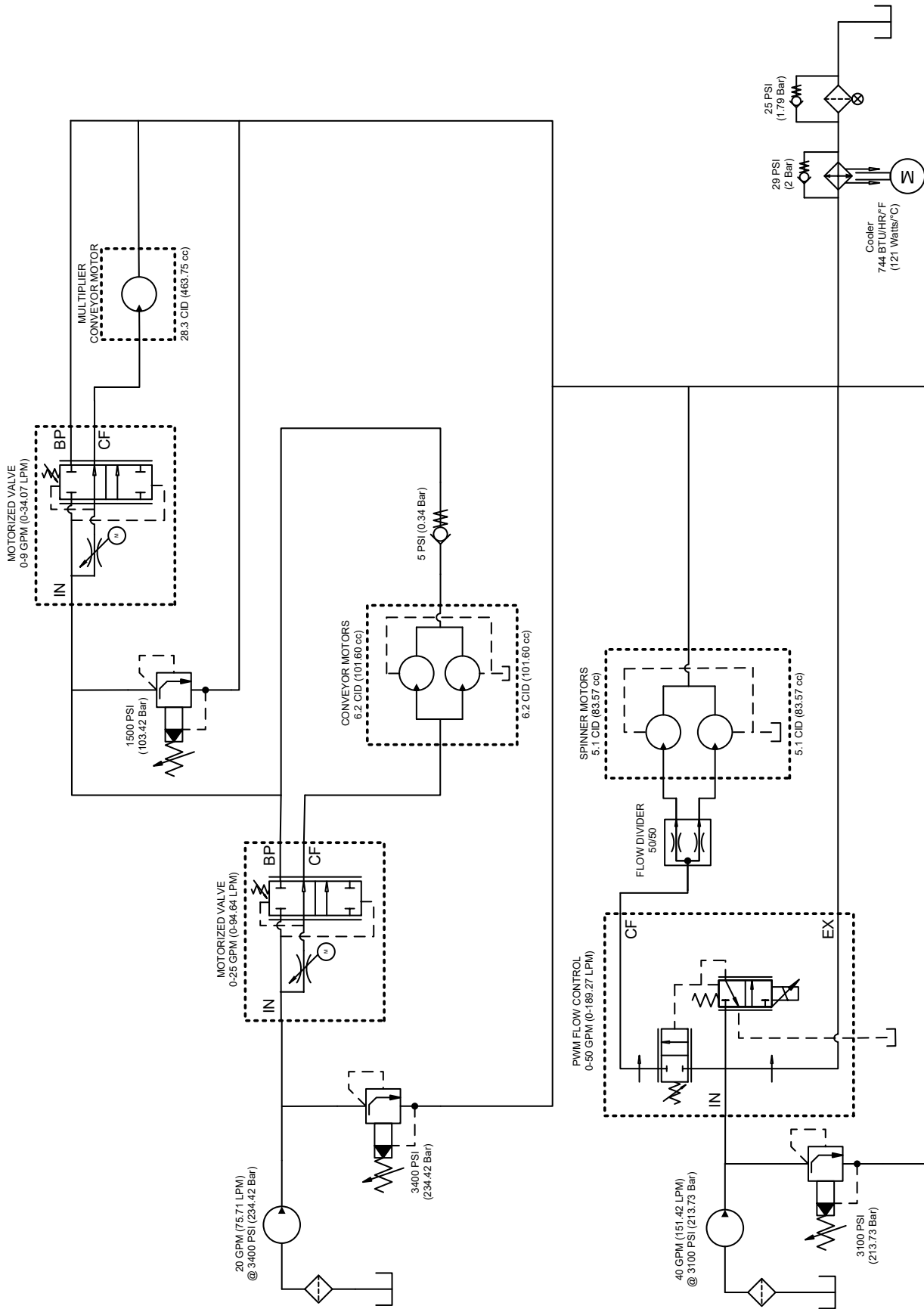

Hi Performance Multiplier Complete Hydraulic Flow Diagram

L4000G4

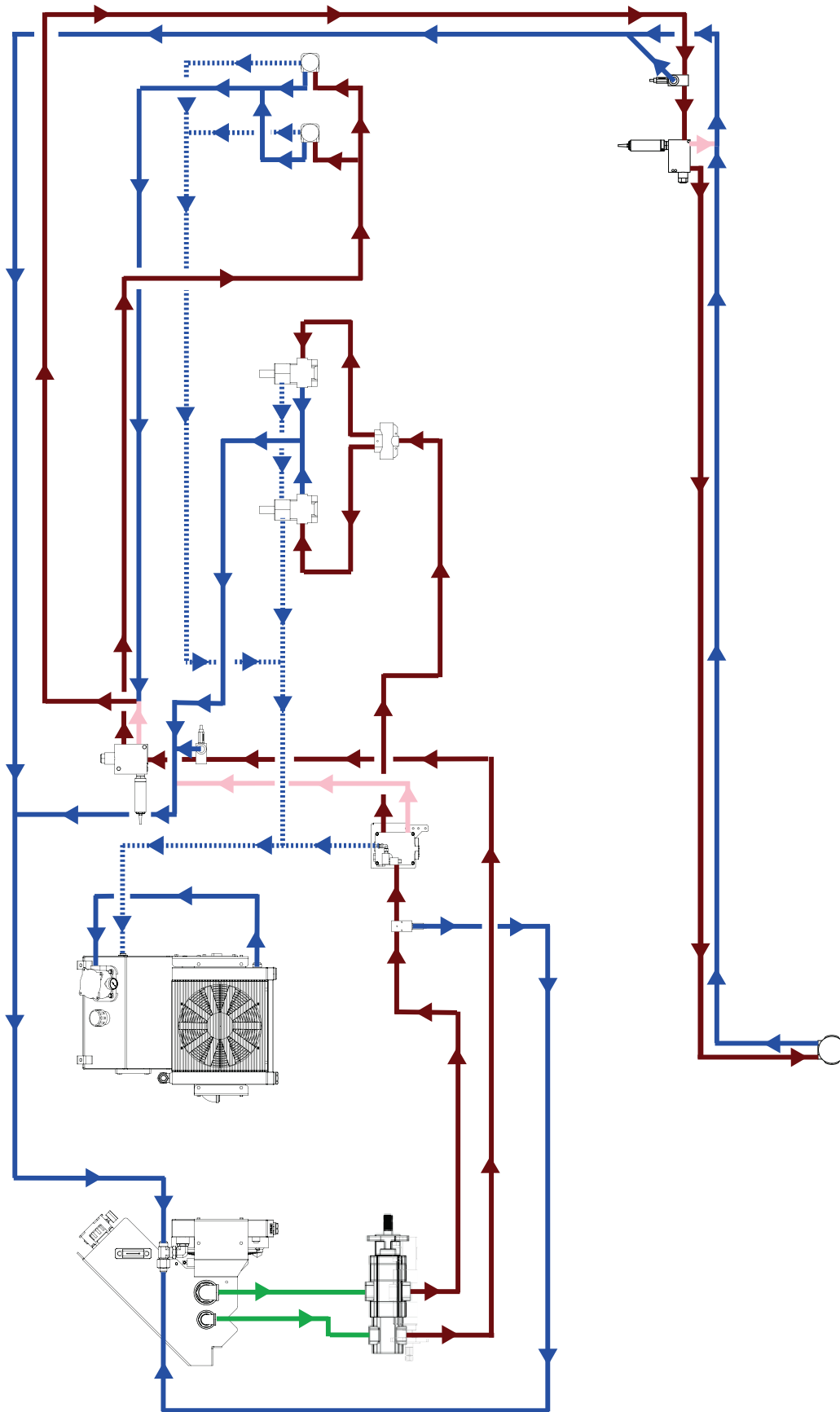

LEGEND	
(HIGH PRESSURE)	CONTROL FLOW
(HIGH PRESSURE)	EXCESS FLOW
(LOW PRESSURE)	RETURN FLOW
(LOW PRESSURE)	CASE DRAIN
(LOW PRESSURE)	SUCTION FLOW
(HIGH PRESSURE)	PRESSURE ONLY
(HIGH PRESSURE)	BI-DIRECTIONAL FLOW
(HIGH PRESSURE)	LOAD SENSE



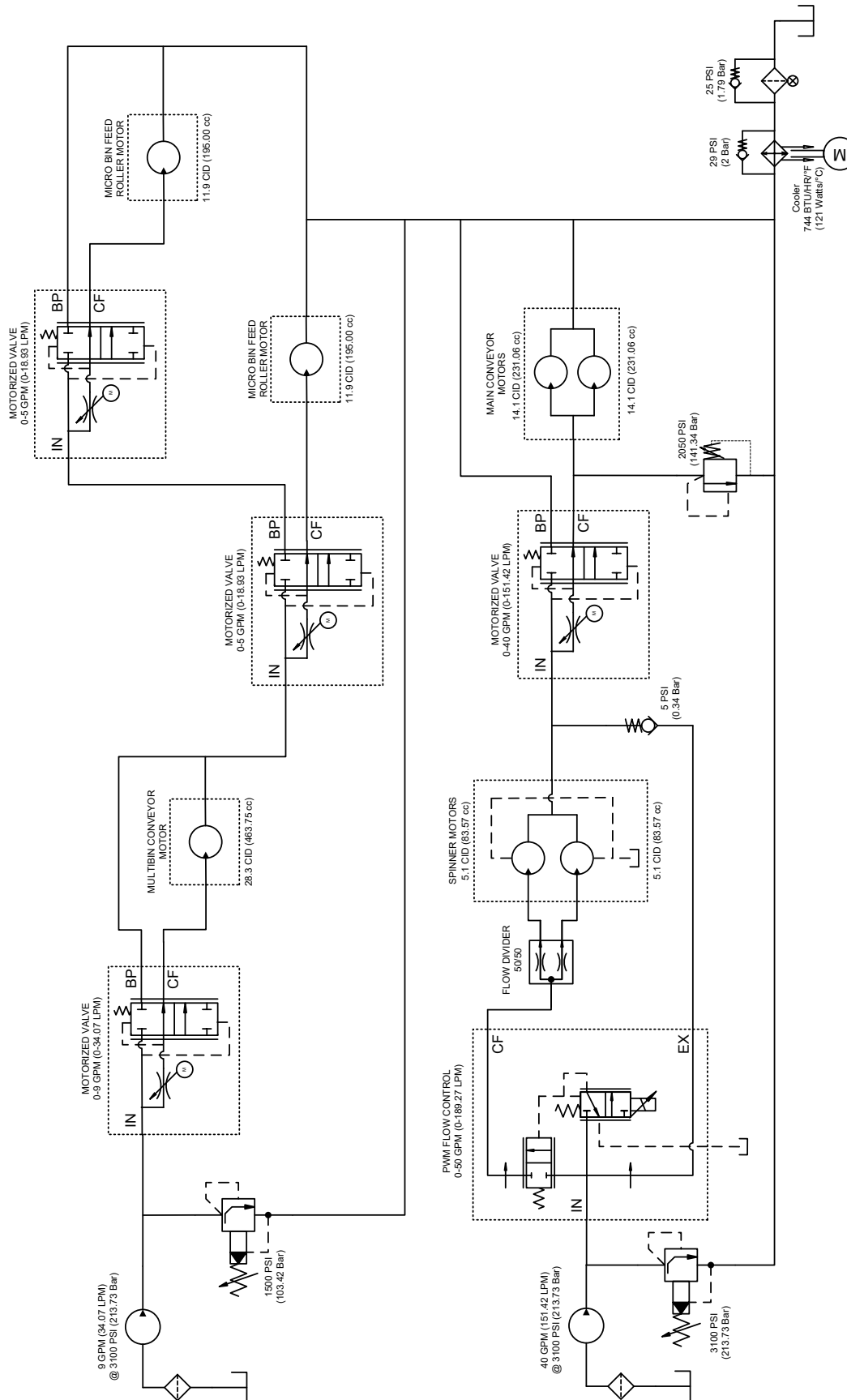

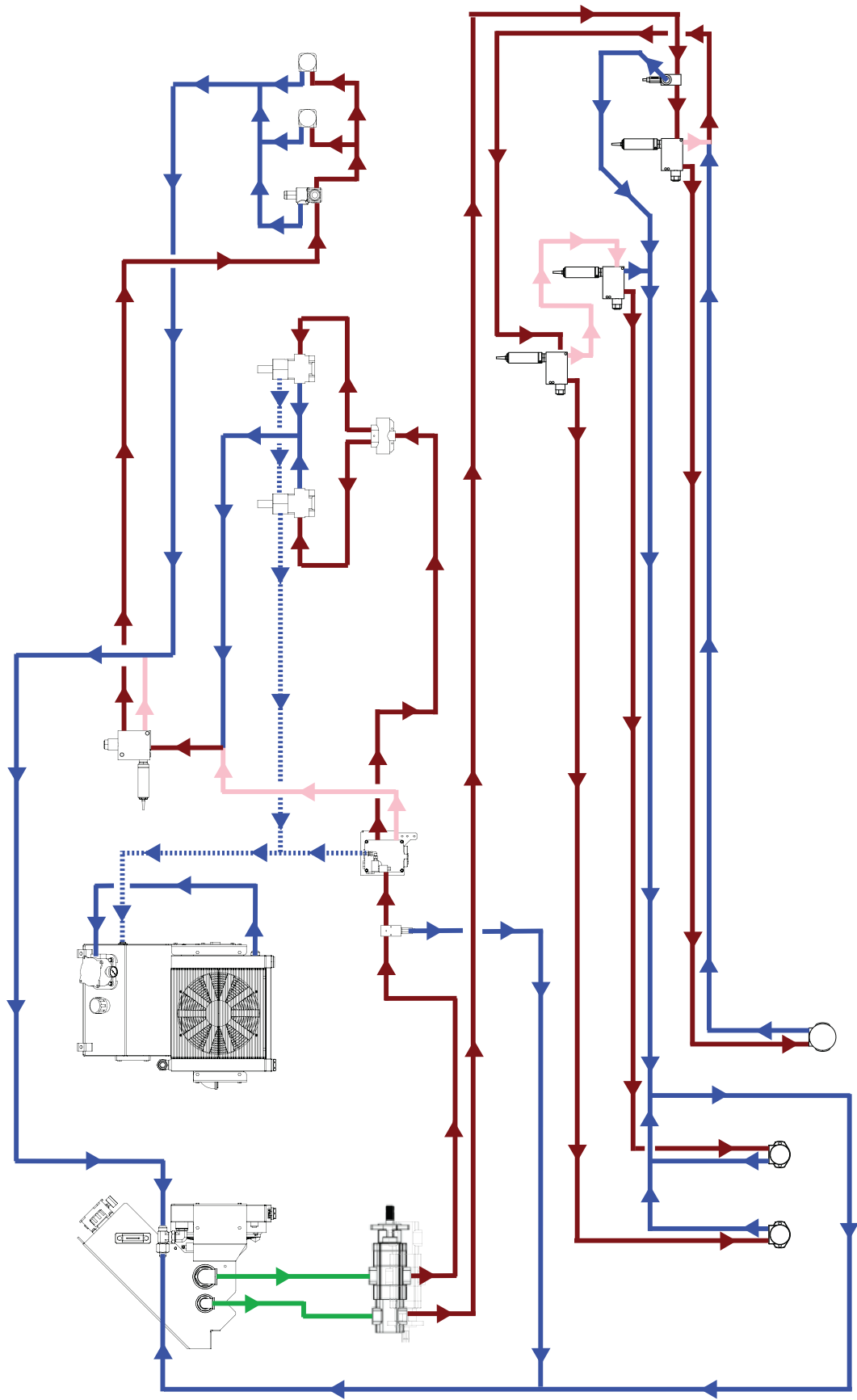

LEGEND

(Solid Blue Line)	CONTROL FLOW	(High Pressure)
(Solid Red Line)	EXCESS FLOW	(High Pressure)
(Solid Pink Line)	RETURN FLOW	(Low Pressure)
(Dotted Blue Line)	CASE DRAIN	(Low Pressure)
(Dotted Green Line)	SUCTION FLOW	(High Pressure)
(Dotted Orange Line)	PRESSURE ONLY	(High Pressure)
(Dotted Purple Line)	BI-DIRECTIONAL FLOW	(High Pressure)
(Dotted Brown Line)	LOAD SENSE	(High Pressure)

This page is intentionally left blank.

**SPREAD
PATTERN**

**SPREAD
PATTERN**

⚠ WARNING

Use great caution while working around the spreader. Contact with spinners and other moving parts is very dangerous. Do not adjust while machinery is moving, wear eye protection and avoid discharge from spinners. Do not ride on moving spreader. Failure to comply with this requirement could result in death or serious injury.

A Catch Test is required prior to each season, before using a new product, or if a significant visible change has occurred with a product.

Catch Test

The CFR number, or cubic feet per revolution number, is a calibration number entered into the controller to determine rate output from the spreader's conveyor. A catch test is performed to verify accurate rate output per the controller.

NOTE: An optional calibration chute (P/N 312688) is available to simplify the catch test process. The calibration chute fits all New Leader spreader models with 30" wide conveyor bottoms. Contact your local New Leader dealer for details.

⚠ WARNING

To prevent injury, disable the spinners by unplugging the PWM valve before beginning the catch test procedure. Failure to comply with this requirement could result in death or serious injury.

1. Disable the spinners by unplugging the PWM valve(s).
2. Move the spinner assembly to the 4" (102mm) position.
3. Remove the Material Divider back plate, and Vane Assembly (if applicable). Install calibration chute if available.
4. Position an end loader or other suitable device beneath the spinners to catch material.
5. Load material into all applicable bins.
6. Prime the conveyor as specified per the controller.
 - If using a calibration chute, run the conveyor just until material reaches the end. Remove any excess material that falls into the catching device.
 - If not using a calibration chute, run the conveyor until the spinner discs are full of material. Remove any excess product from the catching device. Do not remove material from spinner discs.
7. Measure the depth of material on the end of the conveyor to verify the constant number feedgate height information entered into the controller. Adjust feedgate height or recalibrate feedgate as necessary.
8. Verify that all other product settings entered into the controller are correct.
9. Select the correct bin in the controller for the first bin to be tested. Enter the anticipated weight of product to be dispensed from the conveyor.
10. Start the engine and engage hydraulics. Allow to run for several minutes to bring hydraulic oil up to operating temperature. Bring engine up to operating RPM.
11. Following the setup wizard on the controller, run the catch test. The conveyor will start dispensing material, and automatically shut off when the estimated amount of product is dispensed.
12. If not using a calibration chute, leave the material on the spinner discs. Weigh the amount of product that the conveyor actually dispensed into the catching device, and note the result.
13. Enter the actual weight of material dispensed into the controller. The controller will then automatically perform the calibration.
14. Repeat Steps 5 - 12 for all other applicable bins, if an insert bin is installed.
15. Once satisfactory results have been achieved for all applicable bins, turn the engine off, replace the back plate on the Material Divider, return the spinner assembly to its original position setting, and plug the PWM valve(s) back in.

NOTE: For more information on controller operations and setup, contact your local dealer.

⚠ WARNING

Use great caution while working around the spreader. Contact with spinners and other moving parts is very dangerous. Do not adjust while machinery is moving, wear eye protection and avoid discharge from spinners. Do not ride on moving spreader. Failure to comply with this requirement could result in death or serious injury.

NOTICE

Spinner assembly and material divider have NOT been adjusted at the factory. Before spreading material, spread pattern tests must be conducted to properly adjust the spread pattern. A spread pattern test kit is available for this purpose.
THE MANUFACTURER OF THIS SPREADER WILL NOT BE HELD LIABLE FOR MISAPPLIED MATERIAL DUE TO AN IMPROPERLY ADJUSTED SPREADER.

Spread Pattern

Product quality will affect spread pattern and product performance. Spread pattern testing is required to ensure proper application of material. Larger products will produce wider swath widths.

Spread pattern is adjusted using one or more of the following:

- Point of material delivery on spinner discs
- Spinner speed
- Angle of the distributor fins on the spinner discs

Since adjustments will vary for each job, trial and experience must be used to determine the adjustments required to obtain the swath width and spread pattern desired.

Spread Pattern Test Kit

Spread Pattern Test Kit, part no. 313960, includes the following:

DESCRIPTION	QTY	DESCRIPTION	QTY
Box - Plastic Storage	1	Scale – Density	1
Center Collection Tray - Blue	1	Data Sheet – 100 Ct. Booklet	1
Collection Tray - Brown	22	Funnel	1
Divider Screen	23	Flag	5
Assy – Test Tube Rack	1	Rope – 120' marked	1
Test Tube	23	Stake	2

NOTE: If desired, a material calibration kit is available to aid in measuring product quality. Contact your local dealer for details.

Spinners

NOTICE

Spinner discs and fins must be kept clean and polished. Even a small build-up on a spinner fin can significantly affect the spread pattern. Rusty, rough, bent or worn fins will produce poor spread patterns.

In general, critical spinner speed will fall somewhere between 600 and 900 RPM. Spinner speed is adjusted by changing the settings in the controller. Proper spinner speed adjustment is critical in obtaining optimal spread patterns. The best spinner speed to use will depend entirely on the material being spread, and must be determined by testing.

Spreader Preparation

The spreader to be tested must be in good mechanical condition and properly adjusted. Refer to operator's manual for details.

All damaged and worn parts must be replaced. Spinner discs and fins must be free of any material build-up, rust or paint.

Fill the hopper with the material to be spread. Run the material out to the end of the conveyor.

Set the feedgate and the in-cab controller to deliver the required rate per acre. Make sure the feedgate is level and the indicator reflects the actual gate opening measured by standing a tape measure vertically in the material.

NOTE: Do not match slope of endgate when making this measurement. Measurement must be perpendicular to conveyor.

Adjust the spinner assembly by turning the crank or, if an actuator is installed, change the setting in the controller. To begin testing, position the spinner according to following chart.

NOTE: This chart is to be used as a reference only to begin testing.

			SIMPLE START SETTINGS			
Material	Density	Ground Speed (mph)	Rate (lbs)	Feedgate (in)	Spinner Frame Setting	Spinner RPM
Lime	90	11*	1000-5000	6	.5"	600
			2000-8000	12	.5"	600
Urea	46	18	110	2.5	4	800
			225	2.5	3.5	800
			450	2.5	2.5	800
Corn Blend	53	18	125	2.5	3.5"	800
			250	2.5	2.5"	800
			500	2.5	0.7	800
All other fertilizer types and blends	64	18	150	2.5	3.5"	800
			300	2.5	2.5"	800
			600	2.5	1.2	800
* 15 mph when using high performance (HP) hydraulics.						

Test Procedure

Using the data sheets supplied with the kit, document all spreader information and adjustments as necessary. See Figure 1.

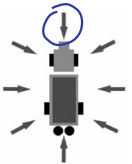
		SPREAD PATTERN DATA SHEET		1330 76th Ave SW Cedar Rapids, IA 52404-7052 (319) 363-8281		
Pattern Test No. <i>1</i>	Rev.	Spreader Model: <i>L4000G4</i>	 (Circle Direction of Wind Relative to Spreader)			
Site: <i>NLM</i>		Serial No. <i>432165</i>				
Date: <i>10/07/2016</i>	Time: <i>10am</i>	Conveyor Type: <i>#4 BOC</i>				
Material Name: <i>MAP</i>		Fan Frame Setting: <i>3.25</i> in.				
Density: <i>65</i> lb/ft ³		Feedgate Height: <i>3"</i> in.				
Crush Strength: <i>6</i>		Fin Position: <i>1-2-1-2</i>				
SGN: <i>324</i>						
Application Rate: <i>320</i> lbs/acre		CFR/Constant: <i>.232</i>				Wind: From <i>Straight</i> at <i>5</i> MPH
						Relative Humidity: <i>41%</i> %
Spinner Speed: <i>780</i> RPM		Controller Vehicle Speed: <i>12</i> MPH				Temperature: <i>67</i> °F
			Controller Swath Width: <i>90</i> ft.			

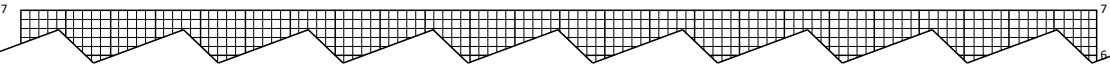

Figure 1

Select an area for testing measuring at least 120 feet x 200 feet (37 m x 61 m), and with a slope of less than two degrees.

All testing should be done when the wind velocity is less than 5 MPH (8.05 km). If wind is present, testing must be done with spreader traveling parallel (within ± 15 degrees) to the wind direction.

Do not allow loaded spreader to sit for more than one hour prior to testing.

At this stage of testing, drive the spreader over the collection trays in ONLY ONE DIRECTION.

Insert a plastic grid into each of the 23 collection trays. Position the blue collection tray in the center of the spreader's path with the longest dimension of the tray parallel to the direction of travel. Position the first left-hand and right-hand trays 10' (3m) from center, and all subsequent trays on 5' (1.5m) centers.

Four-Wheeled Vehicles

For four-wheeled application vehicles, position the spreader at the beginning of the course so that the vehicle will straddle the center collection tray. See Figure 2.

Engage spinners before navigating the course. As the vehicle approaches the flag positioned 75' before the row of collection trays, engage the conveyor(s). Do not shut the conveyor(s) off until the vehicle approaches the second flag.

Drive spreader completely through course at normal operating speeds.

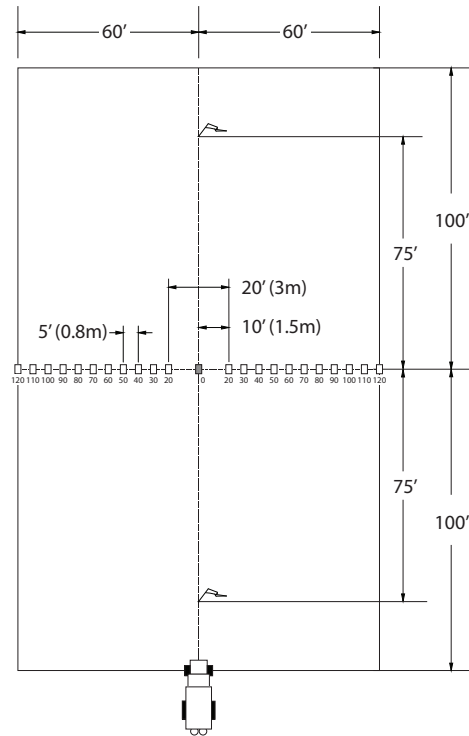

Figure 2 – Four-Wheeled Vehicles

Three-Wheeled Vehicles

For three-wheeled application vehicles, straddling the center tray is not possible. Place the center collection tray beneath the vehicle just behind the front tire when the spreader is in position at the beginning of the course. See Figure 3.

Engage both the spinners and conveyor(s) before navigating the course. Do not shut the conveyor(s) off until the vehicle approaches the second flag.

Drive spreader completely through course at normal operating speeds.

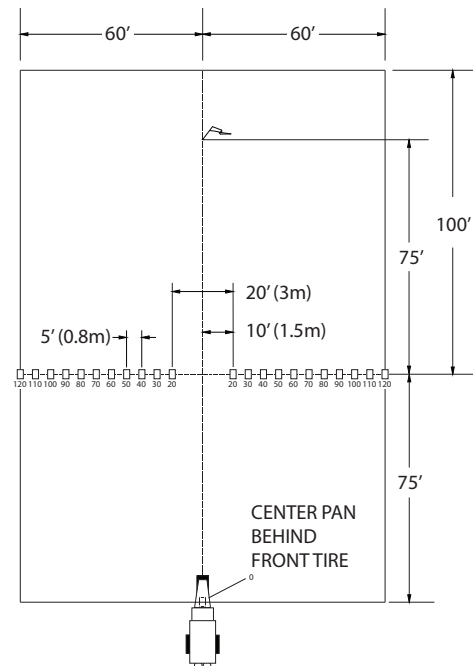

Figure 3 – Three-Wheeled Vehicles

Test Results

After navigating the course, shut the spreader down and park in a secure location.

Using the funnel, transfer the contents of each collection tray into its corresponding test tube beginning at one end of the trays and working towards the opposite end.

If spreading a blend of materials, inspect all tubes to determine if the blend is consistent across the entire swath width. If the blend is not consistent, use a narrower swath width. The swath width should be based on the material thrown the shortest distance.

Record each test tube's volume in the box on the data sheet under the corresponding tray position and graph the spread pattern profile. See Figure 4.

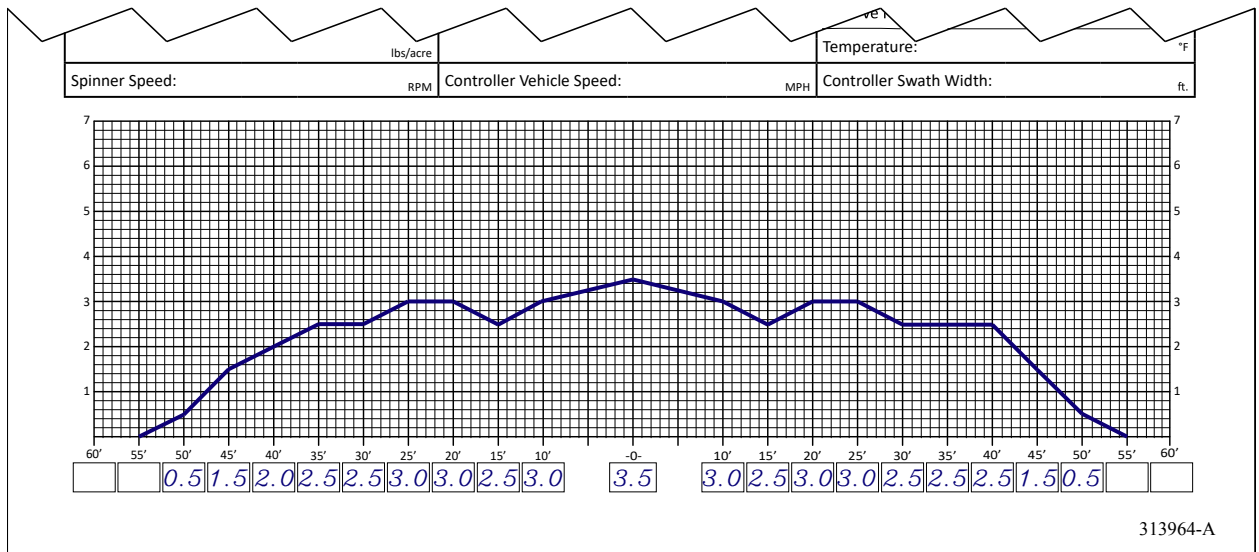

Figure 4

Looking at the material in the test tubes and the graphed profile on the data sheet, compare the overall shape of the spread pattern to the three acceptable patterns, shown in Figure 5. If an acceptable pattern has not been achieved, proceed to "Troubleshooting". Once an acceptable pattern has been achieved, proceed to "Determining Driving Centers".

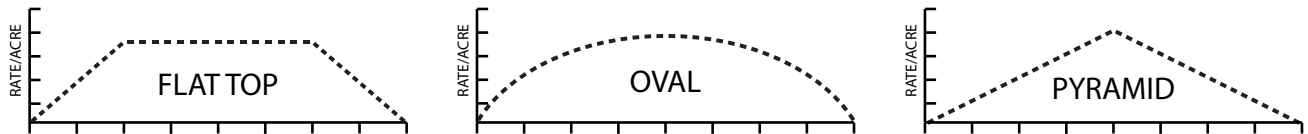

Figure 5 – Acceptable Patterns

Troubleshooting

NOTE: It is highly recommended that **ONLY ONE ADJUSTMENT** be made between test samples taken. If more than one adjustment is made, it will be difficult to determine which adjustment was responsible for the change in pattern shape.

Problem	Pattern	Recommended Adjustments
Heavy Directly Behind the Vehicle		<ol style="list-style-type: none"> 1. Move the spinner forward (toward the conveyor).
Light Directly Behind the Vehicle		<ol style="list-style-type: none"> 1. Move the spinner rearward (away from conveyor).
Light Outside Vehicle's Tire Tracks		<ol style="list-style-type: none"> 1. Check spinner fins for material buildup, rust or paint. 2. Increase spinner RPM. 3. Move spinner fins to 2 - 3 - 2 - 3 positions. See Figure below.
Pattern Off Center		<ol style="list-style-type: none"> 1. Check to see feedgate is level and free of caked material. 2. Make sure hillside divider spinner assembly and material divider are mounted squarely and centered. 3. Testing should be done parallel to wind.

Figure 6

Spinner fins are adjustable to radial angle as shown in Figure 7. Refer to Figure 6 for fin adjustment recommendations.

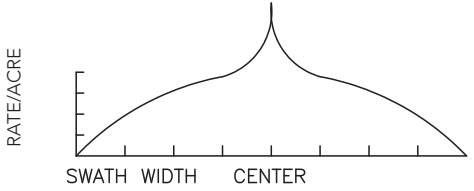
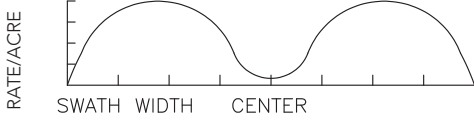
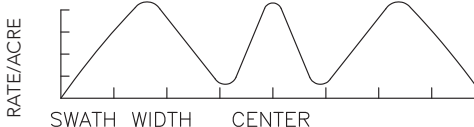
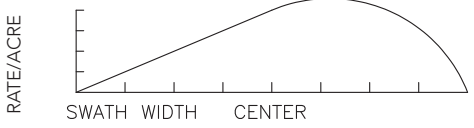
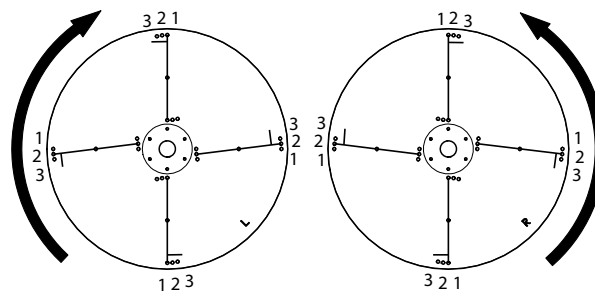

Figure 7 - Spinner Fin Adjustment

Determining Driving Centers

Once an acceptable pattern is obtained, as shown in Figure 5, driving centers can be determined. To determine optimum driving centers (effective swath width), determine the average amount of material in the center of the pattern. Figure 8 shows an example data sheet recorded from the profile shown in Figure 9. Based on the example, the average amount of material in the center of the pattern is 3.0, as indicated with the red dotted line.

Next, locate the points on both the left and right side of the pattern where the amount of material is half the average amount at the center of the pattern. In the example shown in Figure 8, these points are located 45' to the left of center, and 45' to the right of center. The distance between these two points (90') represents the driving centers to use.

NOTE: Once the effective swath width has been established, a change in the controller may be required.

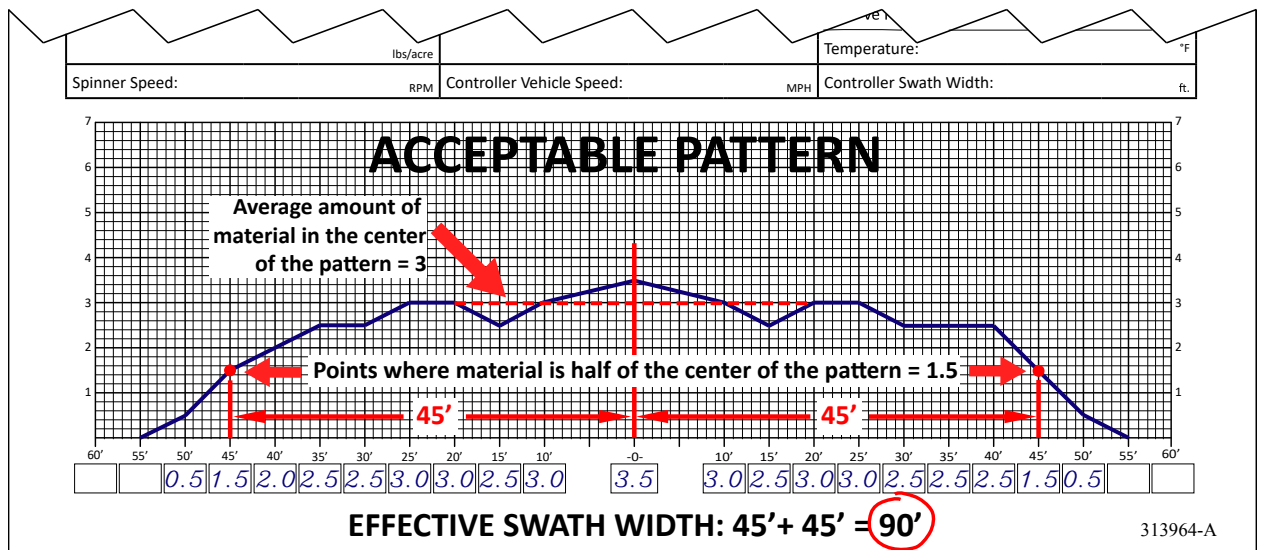

Figure 8 - Effective Swath Width

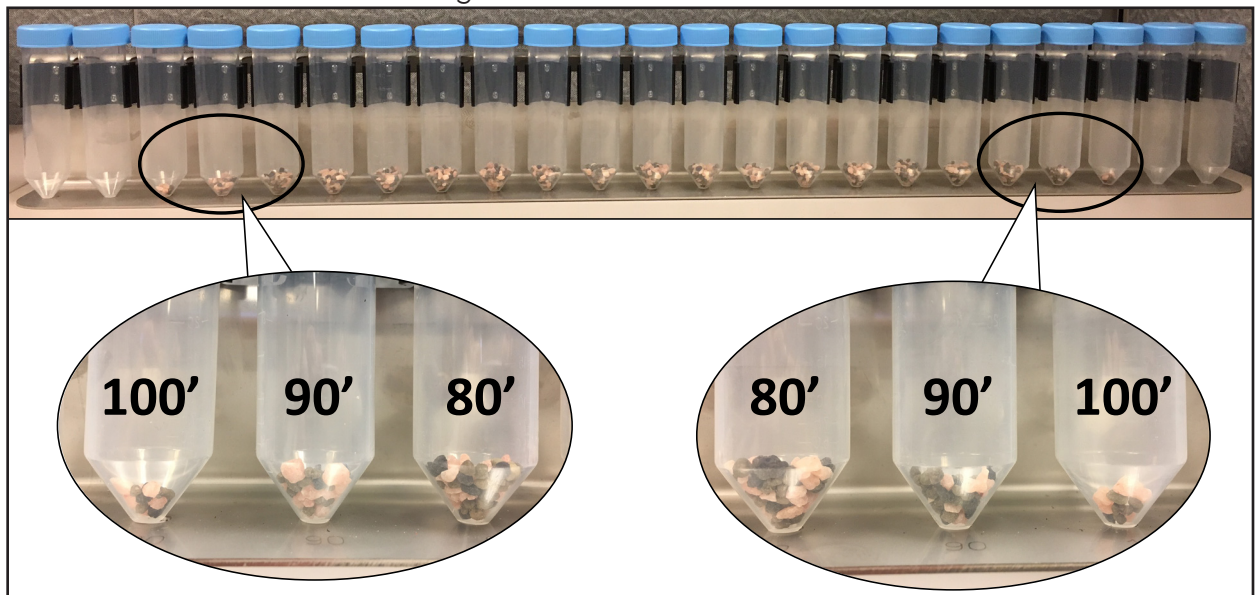

Figure 9

Verifying Driving Centers

Once optimum driving centers (effective swath width) have been established, conduct a final "S" pass over the trays to verify. Refer to Figure 10.

1. With both the spinners and conveyor turned off, drive the spreader through the center of the course, establishing an "AB" line. If the spreader vehicle is a three-wheel type, remove the center pan.
2. Line the vehicle up with either end of the row of collection trays, at a distance from the "AB" line equal to the effective swath width.
3. With both the spinner and conveyor engaged, drive past the trays.
4. Switch back and drive over the center of the trays, down the "AB" line.
5. Drive through the row of trays and switch back once again, driving past the trays on the opposite side, at an equal distance from the "AB" line as the first pass.

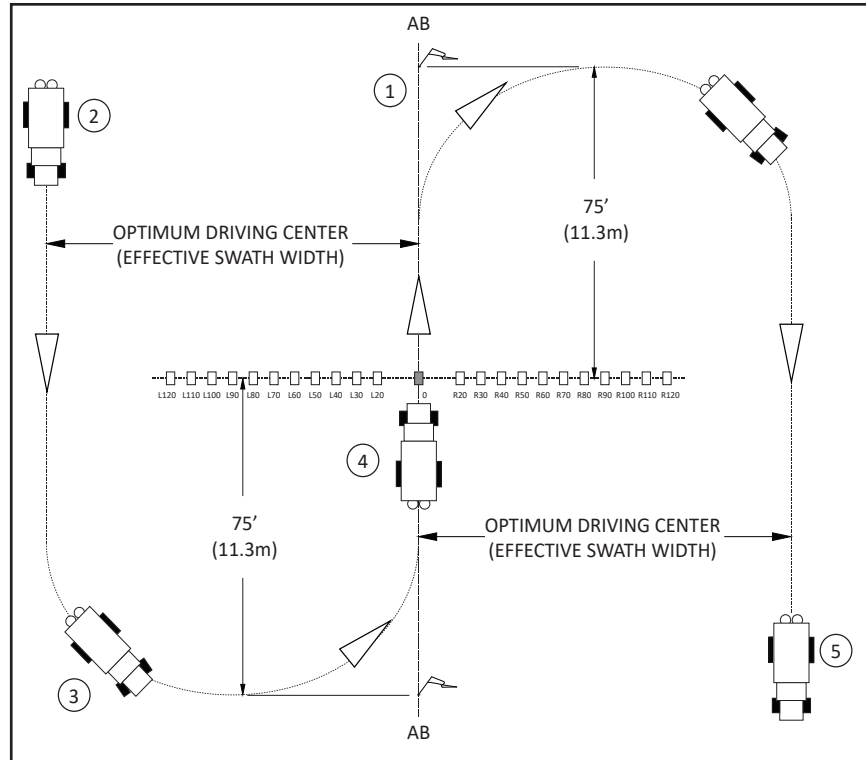

Figure 10

If the driving centers were determined correctly, all trays should have a similar amount of material, showing a near flat profile in the test tubes. If the trays near the center of the row contain more material than the others, increase driving centers. If the trays near the center of the row contain less material, decrease driving centers.

NOTE: If spreading a blend of materials, verify blend of all products is consistent across all tubes.

PARTS

PARTS

Instructions for Ordering Parts

Order from the **AUTHORIZED DEALER** in your area.

Always give the pertinent model and serial number.

Give part name, part number and the quantity required.

Give the correct address to where the parts are to be shipped, and the carrier if there is a preference.

Unless claims for shortages or errors are made immediately upon receipt of goods they will not be considered. Any part returns should be directed through the dealer from which they were purchased.

When broken goods are received, a full description of the damage should be made by the carrier agent on the freight bill. If this description is insisted upon, full damage can always be collected from the transportation company.

No responsibility is assumed for delay or damage to merchandise while in transit. Our responsibility ceases upon delivery of shipment to the transportation company from whom a receipt is received showing that shipment was in good condition when delivered to them, therefore, claims (if any) should be filed with the transportation company and not with New Leader Manufacturing.

If your claims are not being handled (by the transportation company) to your satisfaction, please call our Product Sales & Support Department at New Leader Manufacturing at (800) 363-1771 for assistance.

In the parts list the following symbols and abbreviations stand for:

* - Not Shown
AR – As Required
CS – Carbon Steel
SS – Stainless Steel
NS – Not Serviced

The parts listed under the different steel types (CS, 409 SS and 304 SS) are for that type of unit and do not necessarily mean the part is made of that type of steel.

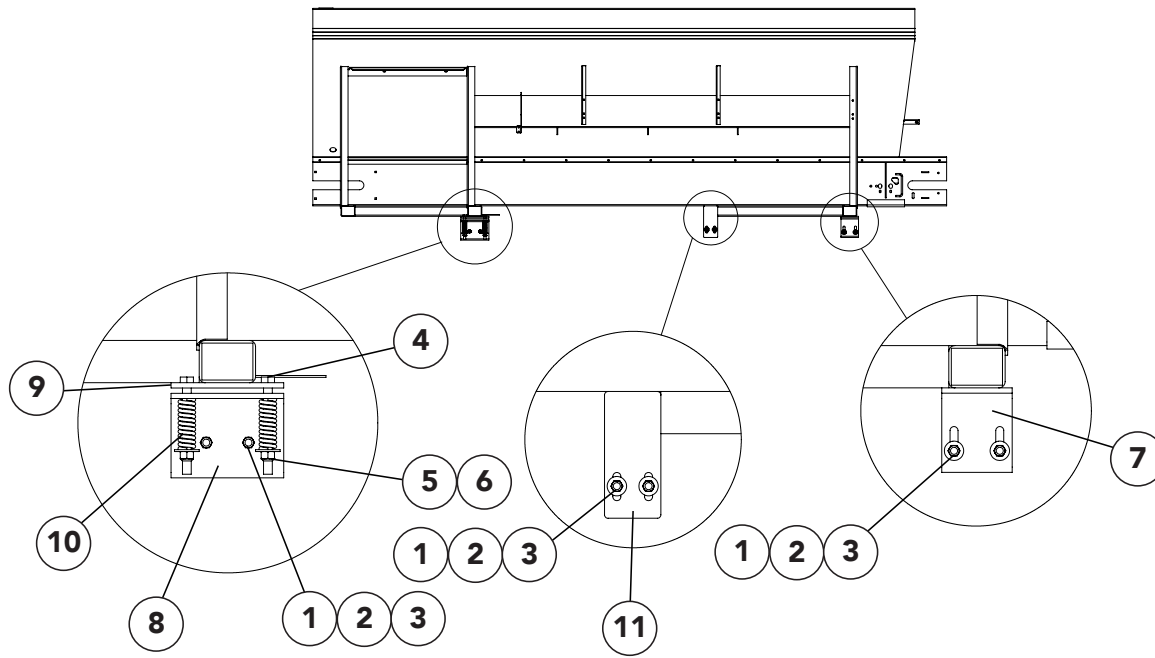

<u>ITEM</u>	<u>PART NO.</u>	<u>DESCRIPTION</u>	<u>QTY</u>
	305579-AB	Hardware Kit - Includes 1 - 6	
1	20131	Cap Screw - 1/2-13NC x 2	12
2	20695	Washer - Flat 1/2	12
3	20680	Nut - Lock 1/2-13NC	12
4	41762	Nut - Lock 5/8-11NC	4
5	20195	Cap Screw - 5/8-11NC x 6-1/2	4
6	20697	Washer - Flat 5/8	4
7	31856	Angle - Mounting	2
8	81847	Angle - Tie Down	2
9	81848	Mounting - Bar	2
10	81000	Spring	4
11	310424	Mounting - Bar	2

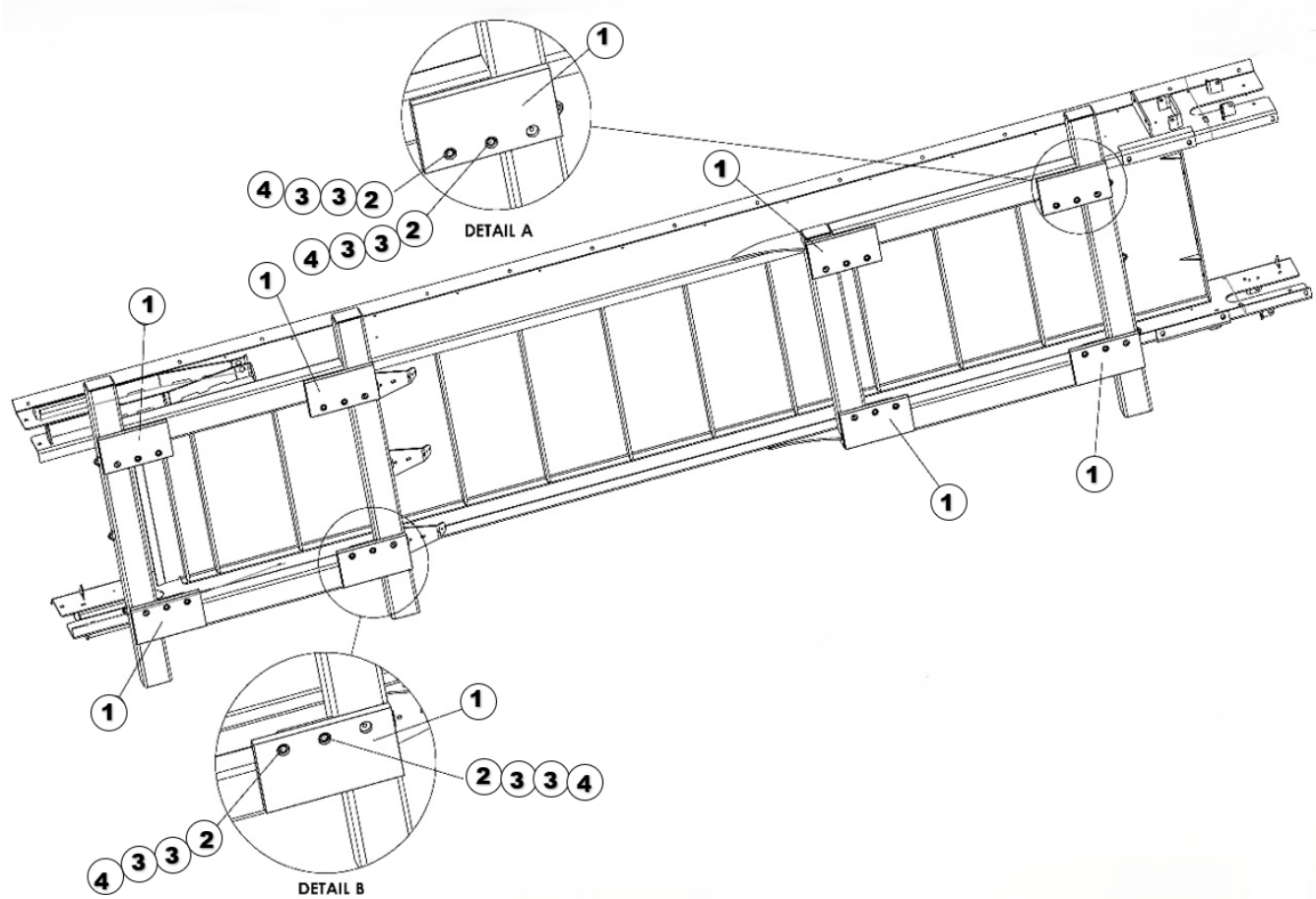

<u>ITEM</u>	<u>PART NO.</u>	<u>DESCRIPTION</u>	<u>QTY</u>
1	323590	Pad - Mount .75 X 5.5 X 10 Poly	8
2	40750	Capscrew - .25 - 20 NC X 1.25 SS	16
3	36423	Washer - Flat .25 SS	32
4	42034	Nut - Lock .25-20NC SS	16

Inverted "V"

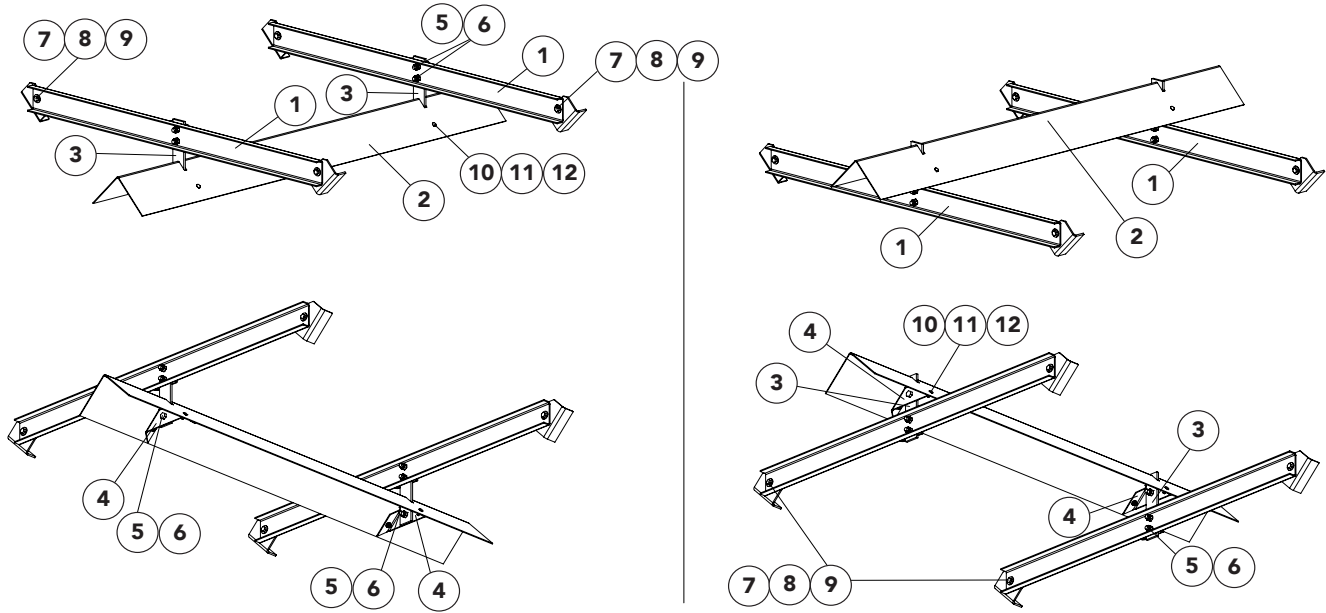

ITEM	PART NO.	DESCRIPTION	QTY
	304 SS		
1	81263	Hanger – V Wldmt	3
2	82623	Inverted V – 9’ (13’ - 14’ Units)	1
3	308646	Bar – Adjusting	3
4	302371	Bracket – V Bolt-on	3
5	58800	Cap Screw – 5/8-11NC x 1-3/4 SS	9
6	41762	Nut - Lock 5/8-11NC SS	9
7	36539	CAPSCREW - .5-13NC X 1.5 SS	6
8	36426	Washer - Flat 1/2 SS	6
9	39016	Nut - Lock 1/2-13NC SS	6
10	42639	Bolt - Carriage 5/16-18NC x 1 SS	6
11	36424	Washer - Flat 5/16 SS	6
12	42221	Nut - Lock 5/16-18NC SS	6

Sight Window

NOTE: LOCATION OF SIGHT WINDOW MAY VARY.

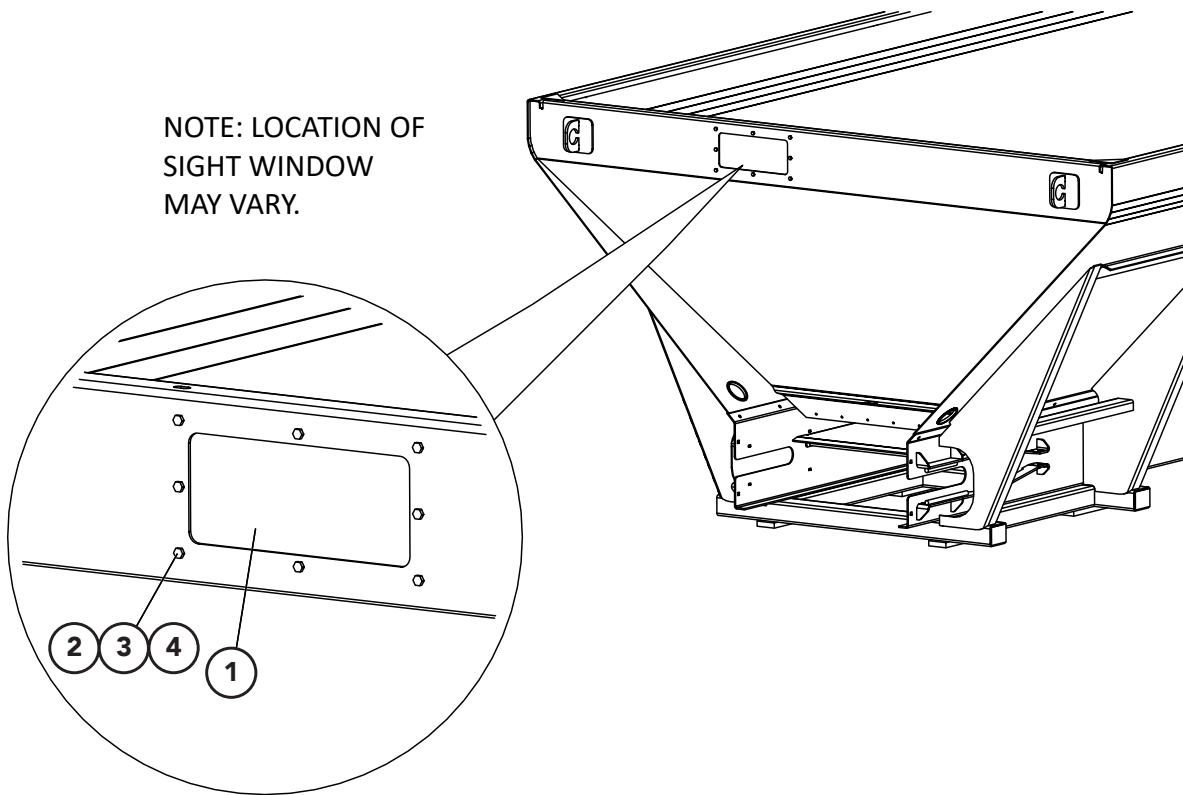

<u>ITEM</u>	<u>PART NO.</u>	<u>DESCRIPTION</u>	<u>QTY</u>
1	302686	Window - Sight 5" x 12"	1
2	36395	Cap Screw - 1/4-20NC x 1 SS	8
3	36423	Washer - Flat 1/4 SS	8
4	42034	Nut - Lock 1/4-20NC SS	8

Body

Side Boards - Single Bin

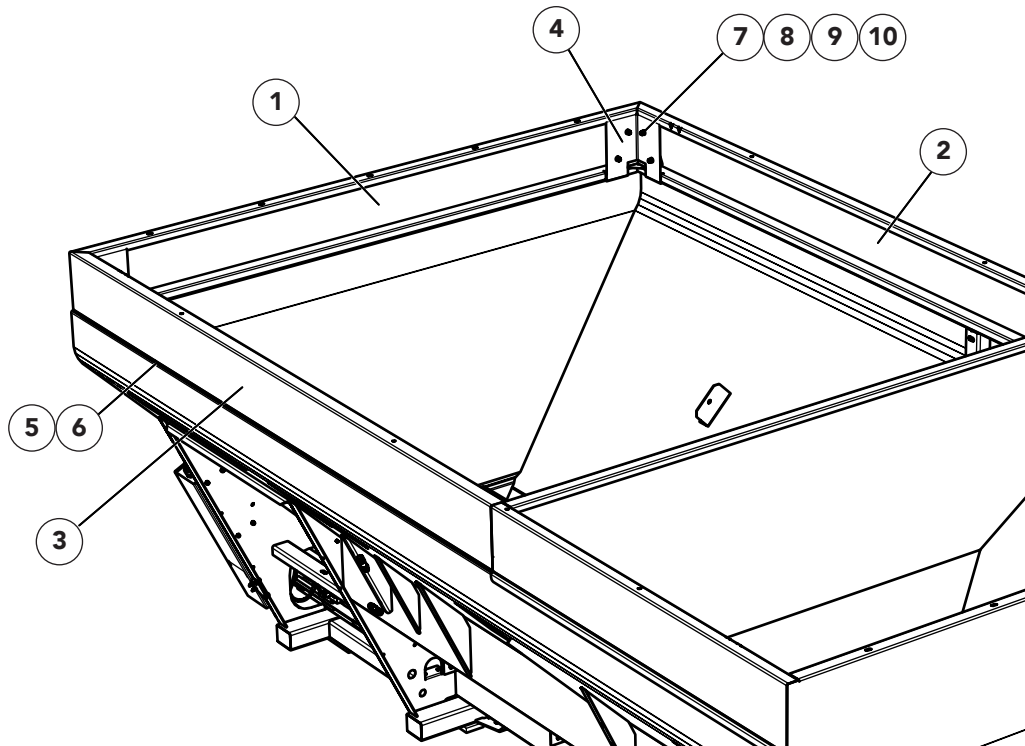

Body**Side Boards - Single Bin**

<u>ITEM</u>	<u>PART NO.</u>	<u>DESCRIPTION</u>	<u>QTY</u>
	98746	Kit - Hardware Side Boards SS, Includes Items 7 - 10	1
1	312601	Side Board – Front Wldmt	1
2	312922	RH Side Board Wldmt - 5'	1
	312924	RH Side Board Wldmt - 6'	1
	312602	RH Side Board Wldmt - 7'	1
	312926	RH Side Board Wldmt - 8'	1
	312928	RH Side Board Wldmt - 9'	1
3	312923	LH Side Board Wldmt - 5'	1
	312925	LH Side Board Wldmt - 6'	1
	312603	LH Side Board Wldmt - 7'	1
	312927	LH Side Board Wldmt - 8'	1
	312929	LH Side Board Wldmt - 9'	1
4	86867	Pocket – Side Board	2
5	53950	Rubber – 1/4 x 2-1/4	AR
6	96254-AB	Adhesive – Blk Cyanoacrylate*	AR
7	36398	Cap Screw – 3/8 x 1	12
8	36425	Washer – Flat 3/8	12
9	36420	Washer – Lock 3/8	12
10	36414	Nut – Hex 3/8	12

AR - As Required

* - Use adhesive to attach rubber to bottom of side boards.

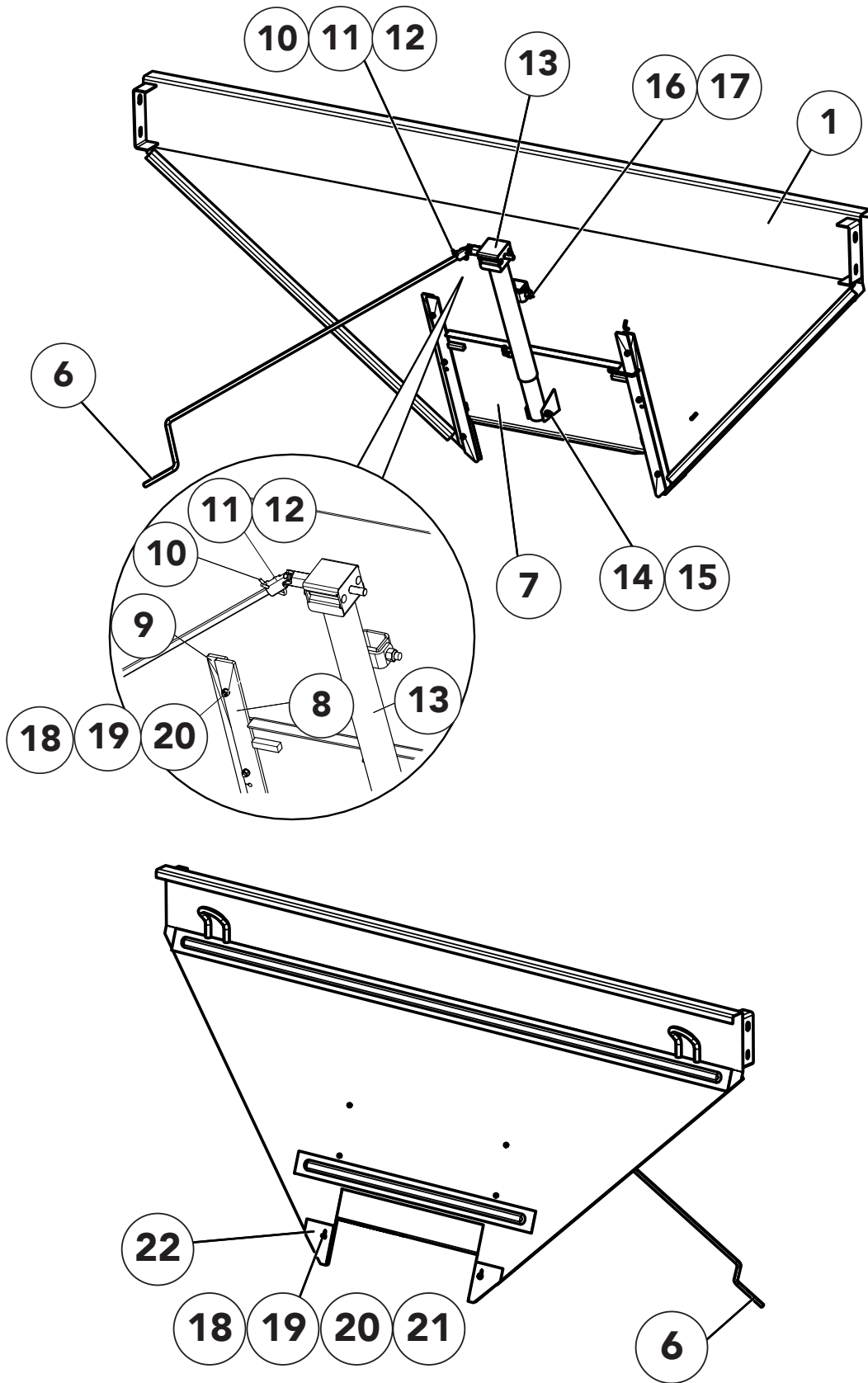

Endgate, Feedgate & Jack

L4000G4

ITEM	PART NO.		DESCRIPTION	QTY
	409 SS	304 SS		
1	86773	86952	Endgate – Removable Wldmt	1
2	*20128-X1	20128-X1	Cap Screw – 1/2 x 1 1/4 Gr8	4
3	*20695	20695	Washer – Flat 1/2	8
4	*20714	20714	Washer – Lock 1/2	4
5	*20646	20646	Nut – Hex 1/2	4
6	72641	72641	Handle	1
7	98512	303937-AA	Feedgate – Wldmt	1
8	36384	36384	Slide – Feedgate	2
9	36385	36385	Guide – Feedgate	2
10	85002	85002	U-Joint	1
11	20918	20918	Pin – Roll	2
12	312994	312994	Jack	1
13	86878	86878	Pin – Hair	1
14	71827	71827	Cap Screw - 3/8 x 3 SS	1
15	72054	72054	Nut – Lock 3/8	1
16	80798	80798	Cap Screw - 1/2 x 3 3/4	1
17	39016	39016	Nut – Hex 1/2	1
18	40750	40750	Cap Screw – 1/4 x 1-1/4	6
19	36418	36418	Washer – Lock 1/4	6
20	36412	36412	Nut – Hex 1/4	6
21	305078	305078	Sealer – Endgate Bolt-in (inside)	2
22	36423	36423	Washer – Flat 1/4	2

* - Not Shown

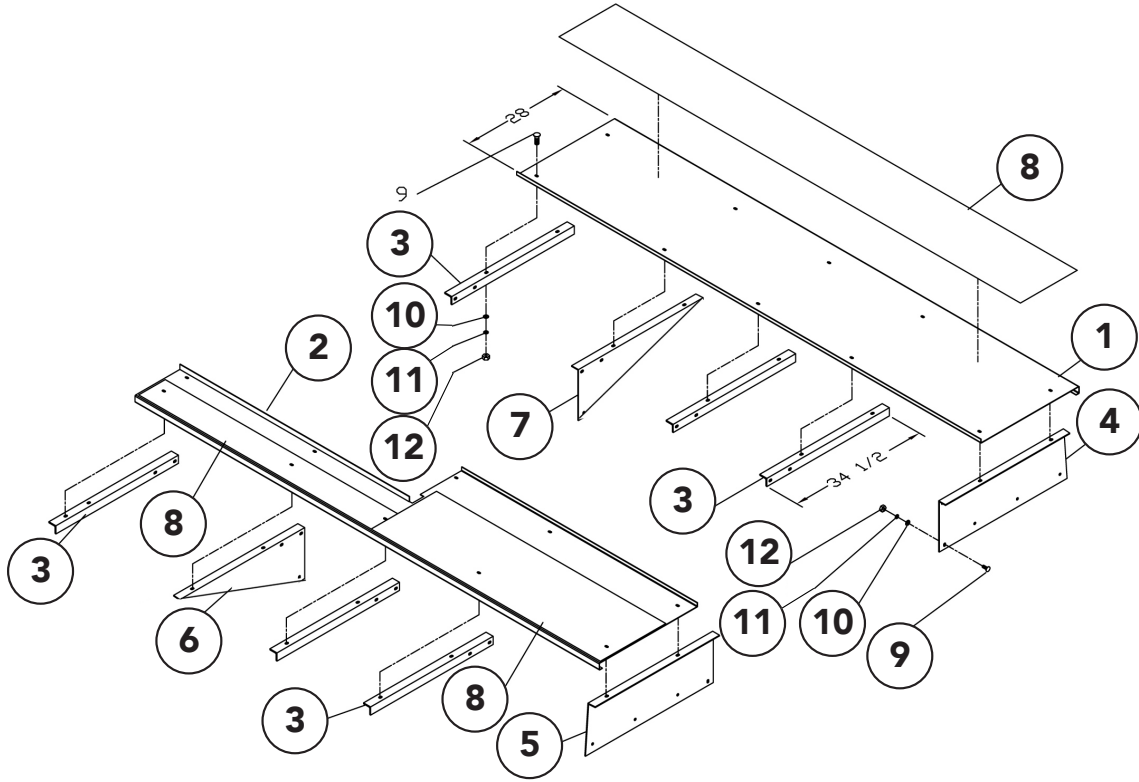

Fenders- Full Flotation Tires

L4000G4

ITEM	PART NO.	DESCRIPTION	QTY	
	<u>409 SS</u>	<u>304 SS</u>		
1	86614-X1 305090	305097 305584	Fender - RH, 13' Unit Fender - RH, 14' Unit	1 1
2	83051-X2 305091	305096 305585	Fender - LH, 13' Unit (with Cutout & Light Mtg Holes) Fender - LH, 14' Unit (with Cutout & Light Mtg Holes)	1 1
3	83021	96969	Angle - Fender	AR
4	83019	96967	Support - RH Rear	AR
5	83020	96968	Support - LH Rear	AR
6	83018	96966	Support - RH Front (without mudflaps)	1
7	83017	96965	Support - LH Front (without mudflaps)	1
8	83124	83124	Material - Non-Skid, 16" Wide	Inches
	21699	21699	Material - Non-Skid, 8" Wide	Inches
9	20318	36408	Bolt - Carriage 3/8 x 1	AR
10	20693	36425	Washer - Flat 3/8	AR
11	36420	36420	Washer - Lock 3/8	AR
12	20644	36414	Nut - Hex 3/8	AR
13	*304245	*304245	Mudflap - Midguard 1/2 x 44 x 36	2

AR - As Required * - Not Shown

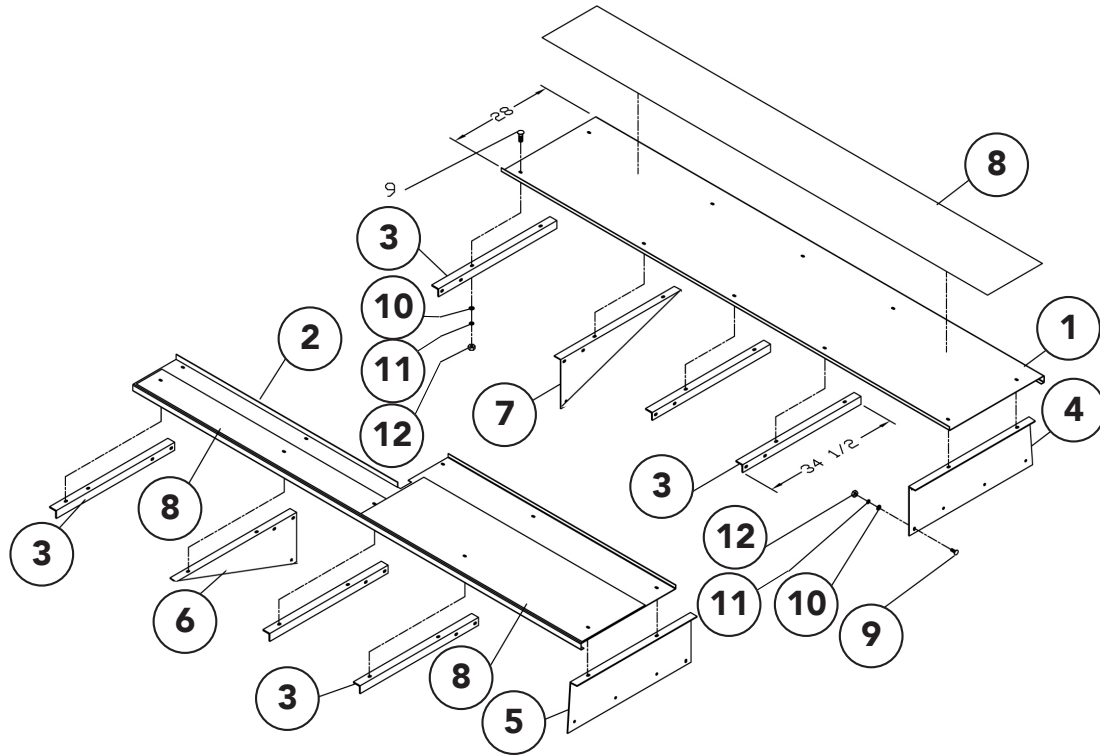

Fenders - Super Flotation Tires

ITEM	PART NO.		DESCRIPTION	QTY
	409 SS	304 SS		
1	86614	86544	Fender - RH, 13' Unit	1
	86604	86620	Fender - RH, 14' Unit	1
2	83286-X1	83302-X1	Fender - LH, 13' Unit (with Cutout & Light Mtg Holes)	1
	83316-X1	83322-X2	Fender - LH, 14' Unit (with Cutout & Light Mtg Holes)	1
3	83256	96972	Angle - Fender	AR
4	83254	83254-X10	Support - RH Rear	AR
5	83255	83255-X10	Support - LH Rear	AR
6	83253	96971	Support - LH Front (without mudflaps)	1
7	83252	96970	Support - RH Front (without mudflaps)	1
8	83124	83124	Material - Non-Skid, 16" Wide	AR
	21699	21699	Material - Non-Skid, 8" Wide	AR
9	20318	36408	Bolt - Carriage 3/8 x 1	AR
10	20693	36425	Washer - Flat 3/8	AR
11	36420	36420	Washer - Lock 3/8	AR
12	20644	36414	Nut - Hex 3/8	AR
13	*304245	*304245	Mudflap - Midguard 1/2 x 44 x 36	2

AR - As Required * - Not Shown

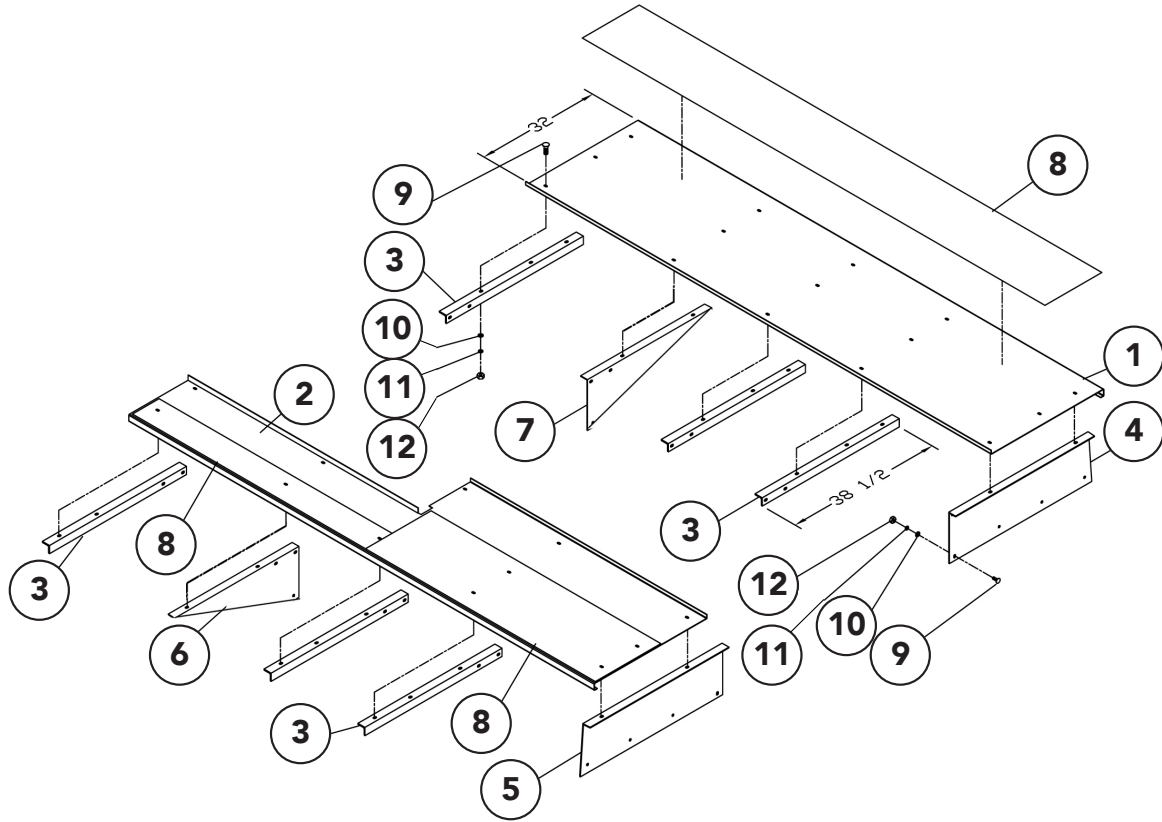

Fenders - Super Flotation Tires w/ 120" Straight Flare

ITEM	PART NO.		DESCRIPTION	QTY
	409 SS	304 SS		
1	86614-X2	86614-X2	Fender - RH, 13' Unit	1
	86604-X1	86604-X1	Fender - RH, 14' Unit	1
2	83286-X2	83286-X2	Fender - LH, 13' Unit (with Tank Cutout)	1
	86605-X1	86605-X1	Fender - LH, 14' Unit (with Tank Cutout)	1
3	83256-X3	96972-X1	Angle - Fender	AR
4	83254-X13	83254-X12	Support - RH Rear	AR
5	83255-X13	83255-X12	Support - LH Rear	AR
6	83253-X8	96971-X1	Support - LH Front (without mudflaps)	1
7	83252-X7	96970-X1	Support - RH Front (without mudflaps)	1
8	83124	83124	Material - Non-Skid, 16" Wide	AR
	21699	21699	Material - Non-Skid, 8" Wide	AR
9	20318	36408	Bolt - Carriage 3/8 x 1	AR
10	20693	36425	Washer - Flat 3/8	AR
11	36420	36420	Washer - Lock 3/8	AR
12	20644	36414	Nut - Hex 3/8	AR
13	*304245	*304245	Mudflap - Midguard 1/2 x 44 x 36	2

AR - As Required * - Not Shown

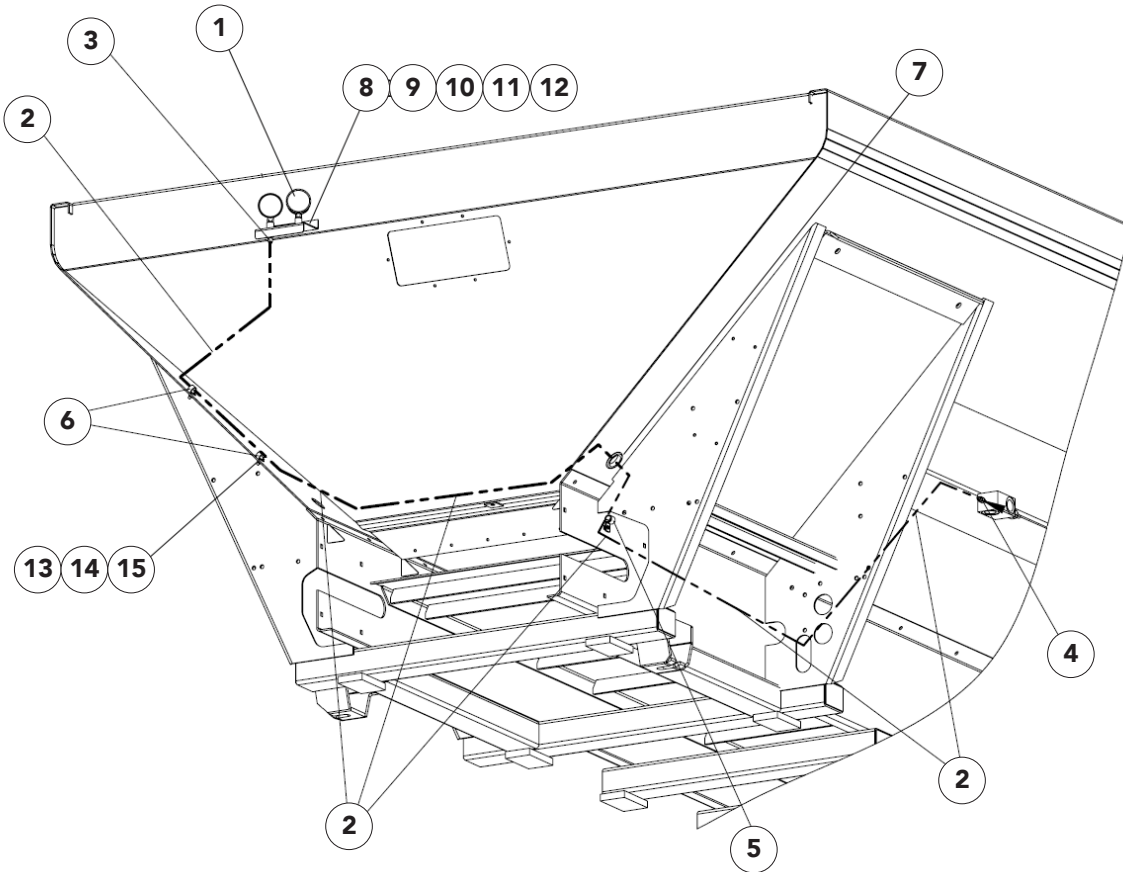

*Note: 306797 Assy Shown

<u>ITEM</u>	<u>PART NO.</u>	<u>DESCRIPTION</u>	<u>QTY</u>
1	76044	Gauge - Hyd. 5000 PSI w/ Built in Snubber	1
	28389	Gauge - Hyd. 30000 PSI w/ Built in Snubber	1
2	306798	Hose - .35" dia. 100R2 x 160" Assy	1
	307509	Hose - .25" dia. 100R2 x 112" Assy	1
	304951	Hose - .25" dia. x 100" 100R1 Assy	1
3	29765	Fitting - 4-4 070102	1
4	29849	Fitting - 4-4 070120	1
	29795	Fitting - 4-4 070220	1
5	89051	Clamp - Insulated Closed	AR
6	26562	Clamp - Tubing 1/2	2
7	34129	Grommet - Rubber	1
8	304948	Bracket - Wldmt Gauge	1
9	34580	Cap Screw - 5/16-18NC x 1 SS	2
10	36424	Washer - Flat 5/16 SS	2
11	36413	Nut - Hex 5/16-18NC SS	2
12	36419	Washer - Lock 5/16 SS	2
13	36393	Cap Screw - 1/4-20 NC x 3/4 SS	2
14	36418	Washer - Lock 1/4 SS	2
15	36412	Nut - Hex 1/4-20 NC SS	2

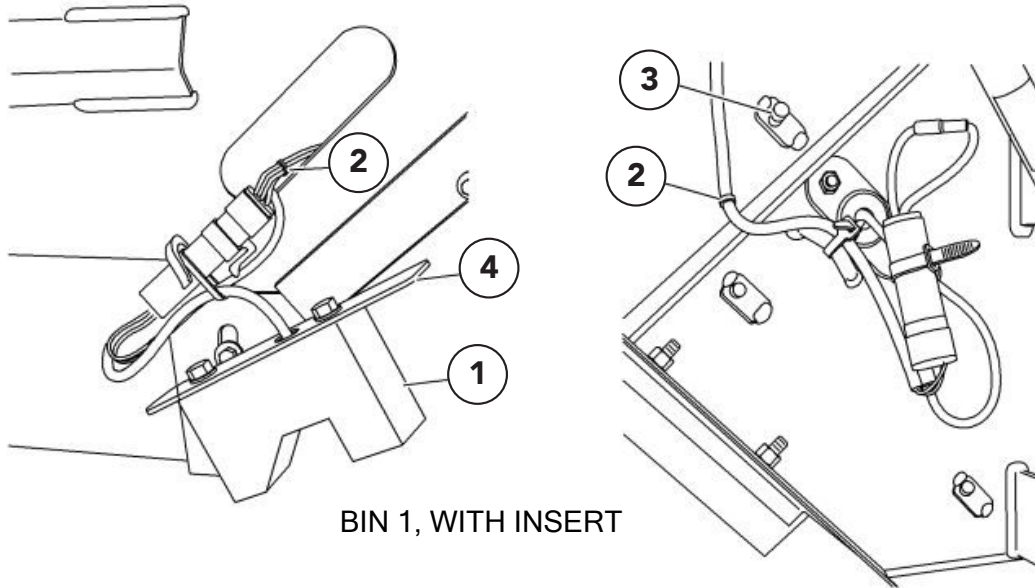

BIN 1, WITH INSERT

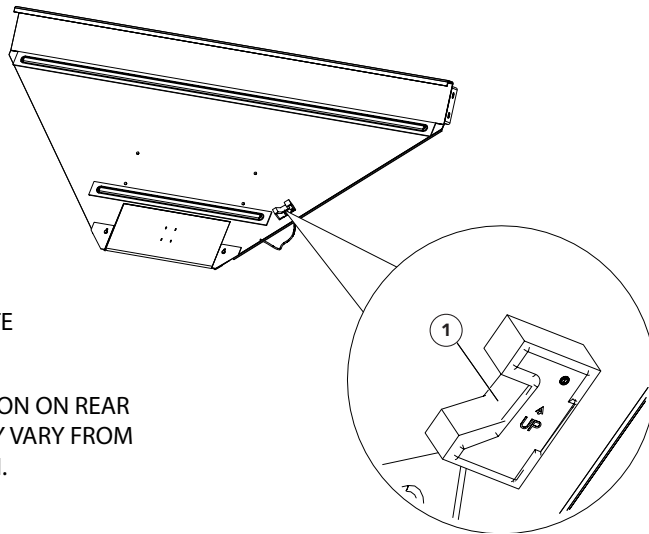

REAR ENDGATE

NOTE: LOCATION ON REAR
ENDGATE MAY VARY FROM
ILLUSTRATION.

<u>ITEM</u>	<u>PART NO.</u>	<u>DESCRIPTION</u>	<u>QTY</u>
1	98787-AB	Sensor - Bin Level w/ 18" Lead	AR
2	307130	Cable - Jumper 102"	AR
3	36393	Cap Screw - 1/4-20NC x 3/4 SS	AR
4	307124	Mount - Sensor 304	AR
5	*98787-AD	Cable - 27" Bin Sensor	AR

* - Not Shown

Standard Hydraulics

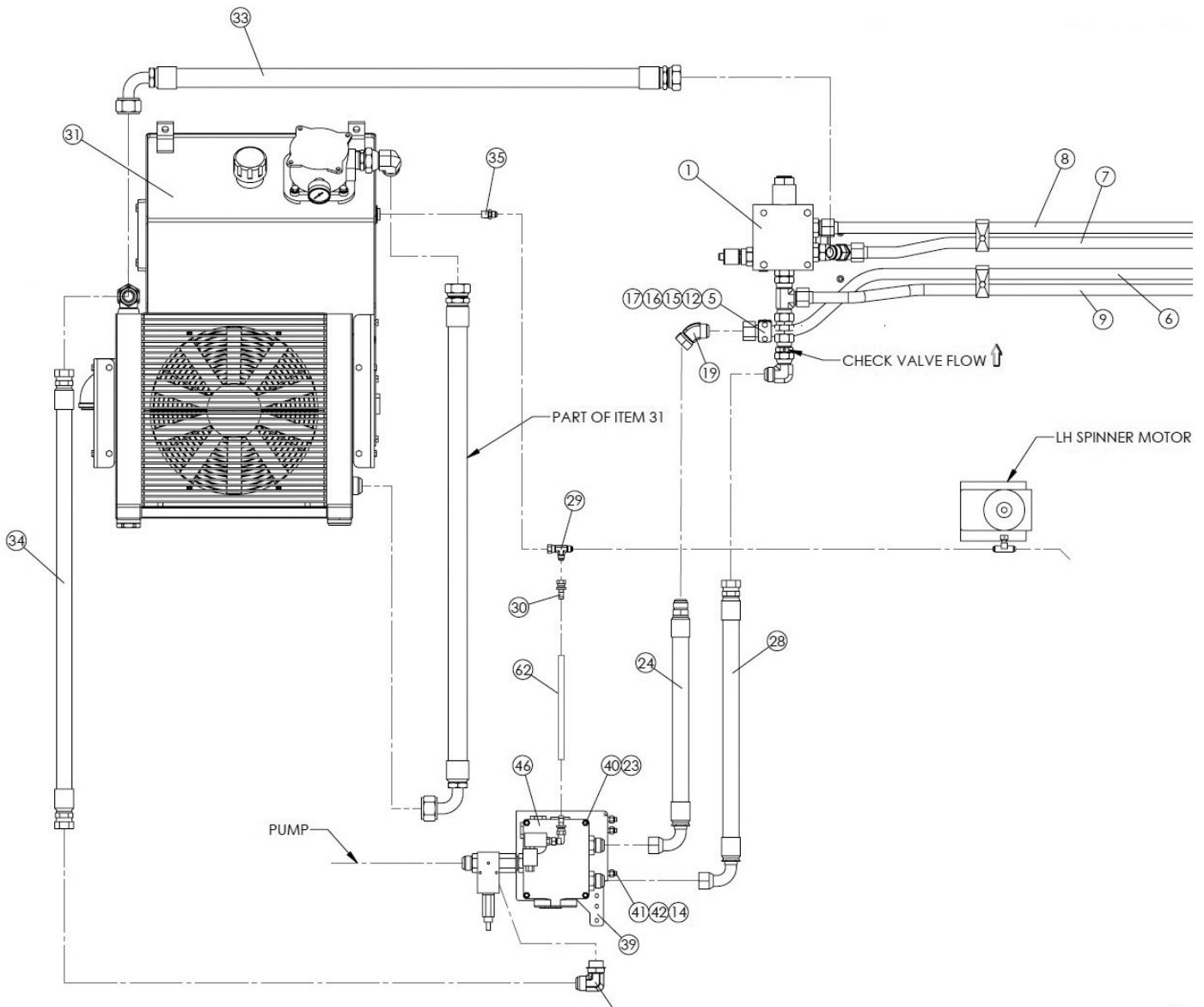

Body Hydraulics

Standard Hydraulics

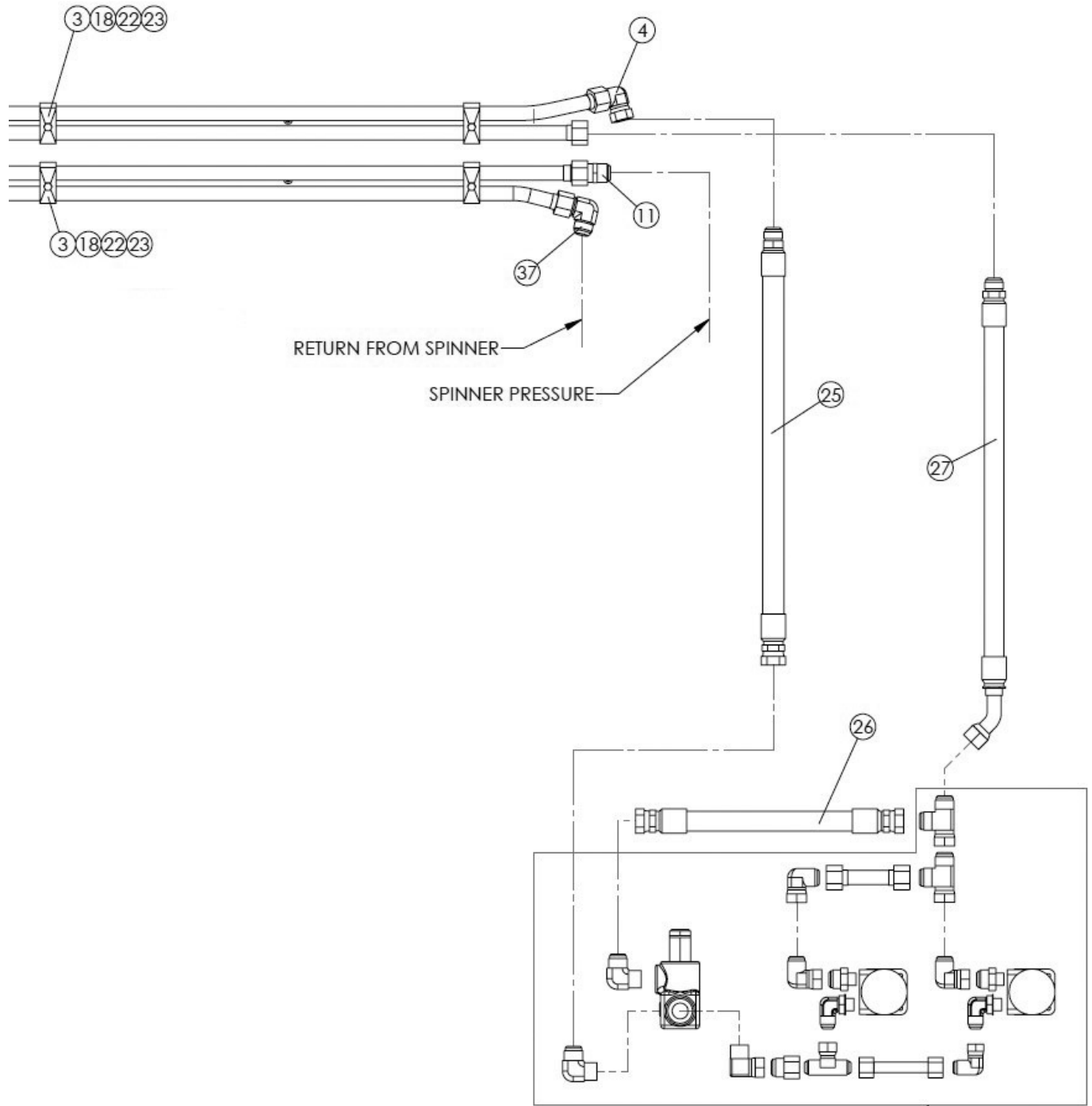

Standard Hydraulics

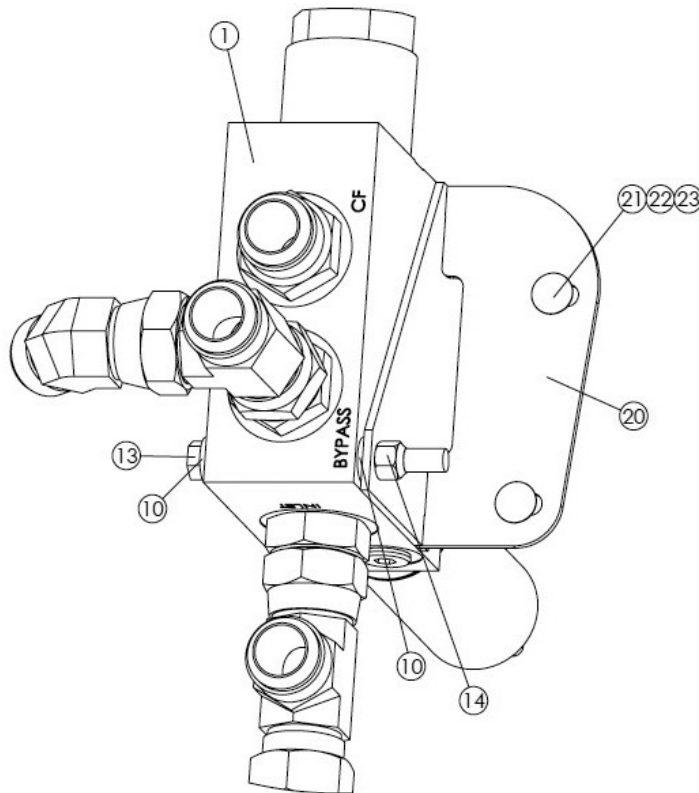
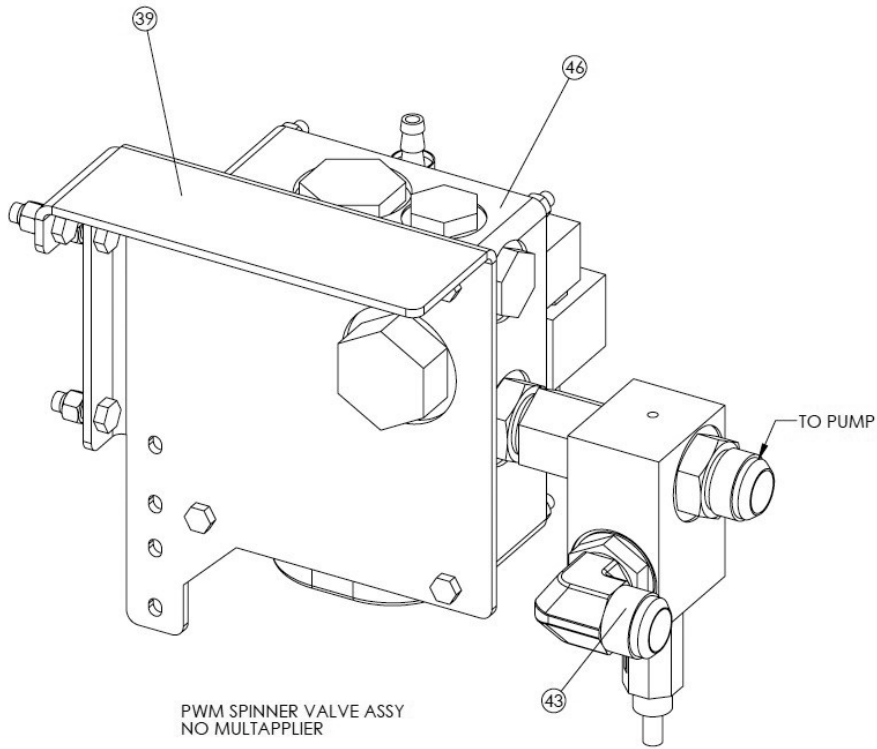

VALVE MOUNT DETAIL

Body Hydraulics**Standard Hydraulics**

ITEM	PART NO.	DESCRIPTION	QTY
1	318271	Valve - Assy	1
	306290	Valve - Assy Sfp 40gpm 304	
2	Not Used		
3	300033	Clamp - Tubing Twin 1	6
4	29807	Fitting - 16-16 070221	1
5	86557	Clamp - Tube 1 2pcs=1set	1
6	302424	Tube - Assy 1od X .083 X 91 13'	1
	302425	Tube - Assy 1od X .083 X 103 14'	1
7	302417	Tube - Assy 1od X .049 X 81 13'	1
	302418	Tube - Assy 1od X .049 X 93 14'	1
8	302410	Tube - Assy 1od X .049 X 85 13'	1
	302411	Tube - Assy 1od X .049 X 97 14'	1
9	302431	Tube - Assy 1od X .049 X 85 13'	1
	302432	Tube - Assy 1od X .049 X 97 14'	1
10	302099	Washer - Step .38id X .53od X	4
11	34719	Fitting - 16-16 070101	1
12	86556	Plate - Cover Hyd Tube Clamp	1
13	34860	Capscrew - .375-16nc X 4 SS	2
14	72054	Nut - Lock .375-16nc SS	5
15	34865	Capscrew - .25-20nc X 2.25 SS	2
16	36423	Washer - Flat .25 SS	2
17	42034	Nut - Lock .25-20nc SS	2
18	71830	Capscrew - .313-18nc X 2.5 SS	6
19	29806	Fitting - 16-16 070321	1
20	305914	Bracket - Wldmt Valve Mounting	1
21	42639	Bolt - Carriage .313-18nc X 1	2
22	36424	Washer - Flat .313 SS	8
23	42221	Nut - Lock .313-18nc SS	12
24	302345	Hose - Assy 1 X 22.5 100r12	1
25	302346	Hose - Assy 1 X 31 100r2	1
26	82319	Hose - Assy 1 X 19 2cb	1
27	42996	Hose - Assy 1 X 32.875 2cb	1
28	56394	Hose - Assy 1 X 27.5 100r2	1
29	98724	Fitting - 6-6-6 070432	1

Standard Hydraulics

<u>ITEM</u>	<u>PART NO.</u>	<u>DESCRIPTION</u>	<u>QTY</u>
30	34761	Fitting - Socketless .56 Jic X	1
31	305751	Tank - Group Hyd Mnt	1
	306082	Tank - Group Hyd Mnt 304	1
32	Not Used		
33	305917	Hose - Assy 1.25 X 40.5 Return	1
34	82599	Hose - Assy 1 X 42 2cb	1
35	29766	Fitting - 6-6 070102	1
36	Not Used		
37	29783	Fitting - 16-16 070201	1
38	Not Used		
39	302397	Bracket - Valve Mount 304	1
40	42794	Capscrew - .313-18nc X 3.75 SS	4
41	36398	Capscrew - .375-16nc X 1 SS	3
42	36425	Washer - Flat .375 SS	3
43	29840	Fitting - 16-16 070220	1
46	305910	Valve - Assy Hyd Pwm Valve	1
62	34195-48	Hose - .375 X 48	1

This page is intentionally left blank.

Hi Performance Hydraulics

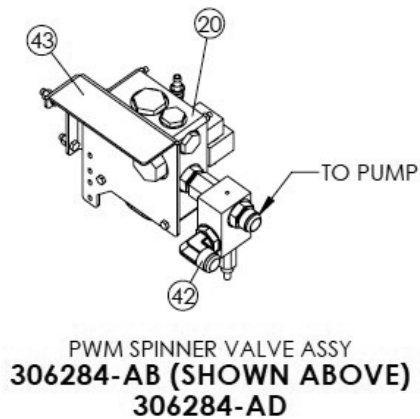
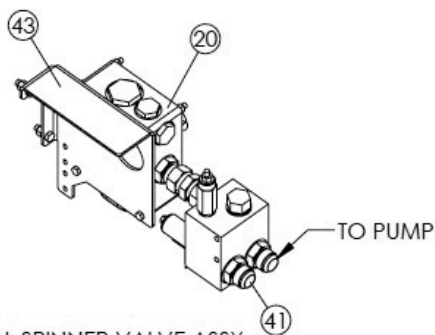
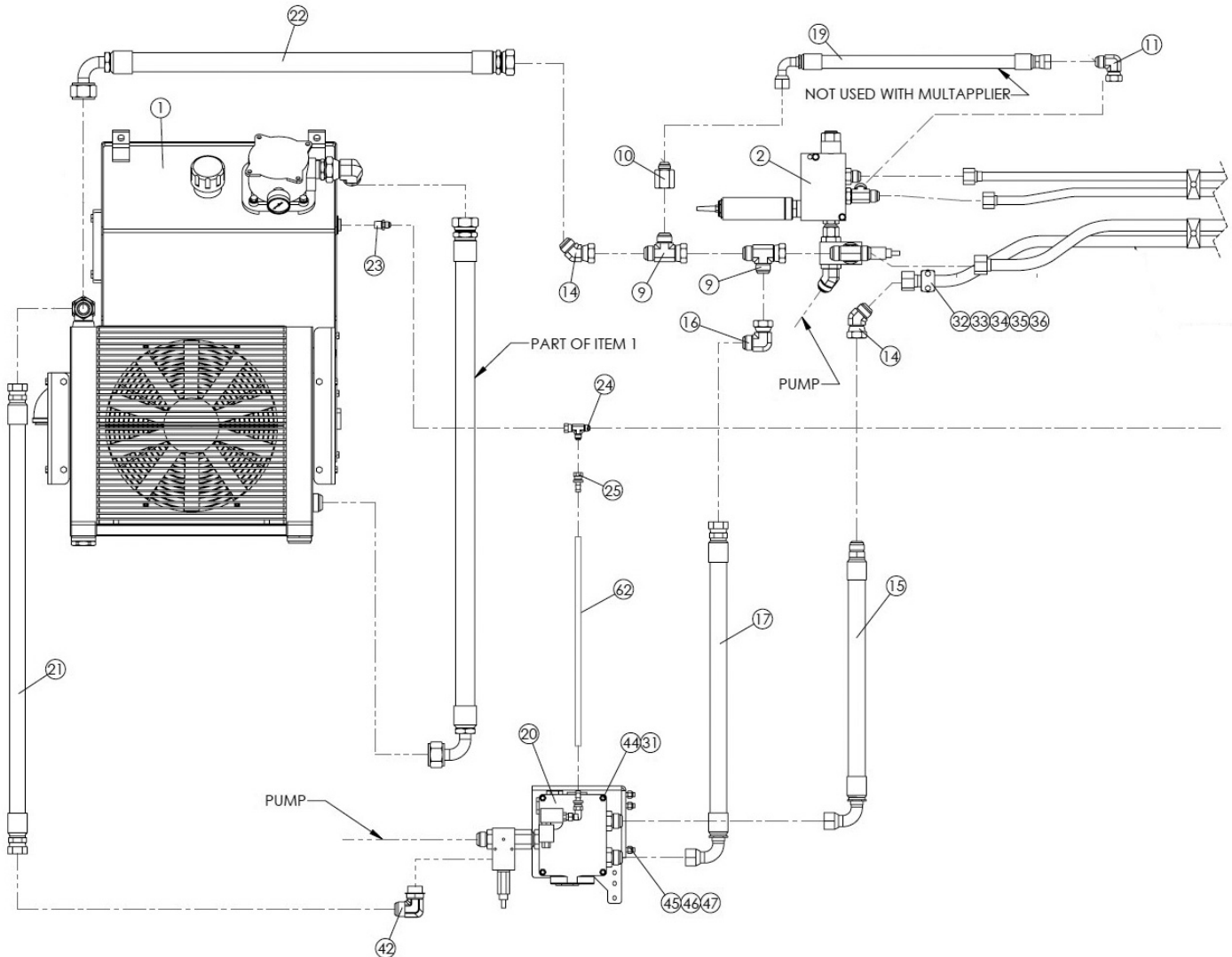

Hi Performance Hydraulics

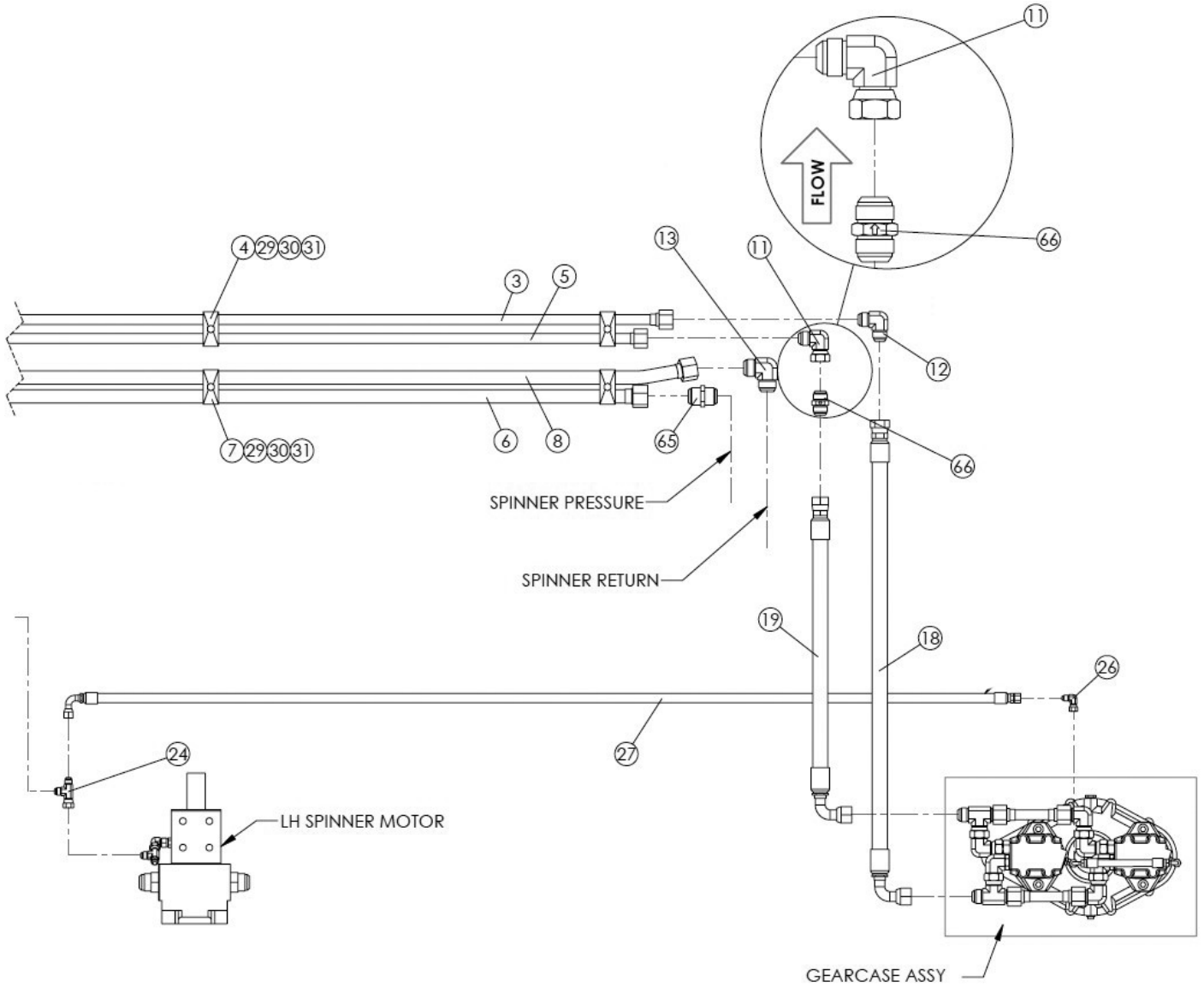

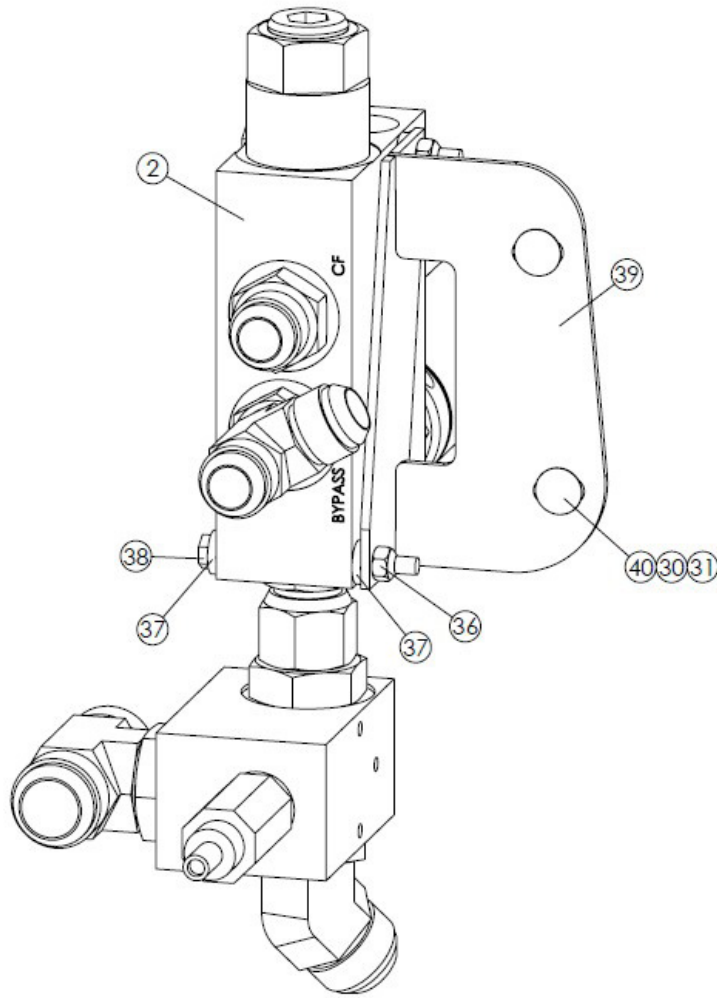

VALVE MOUNTING DETAIL

Body Hydraulics

Hi Performance Hydraulics

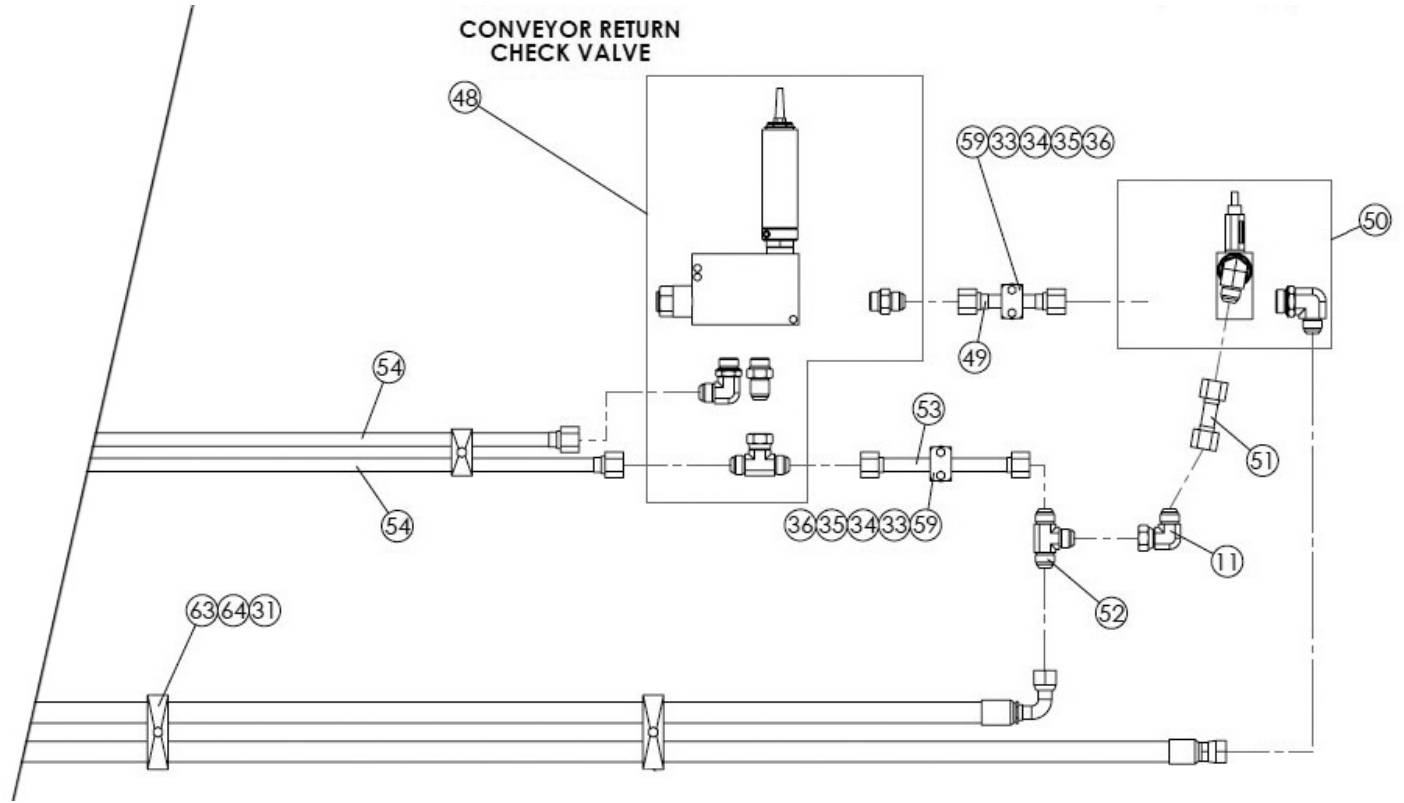
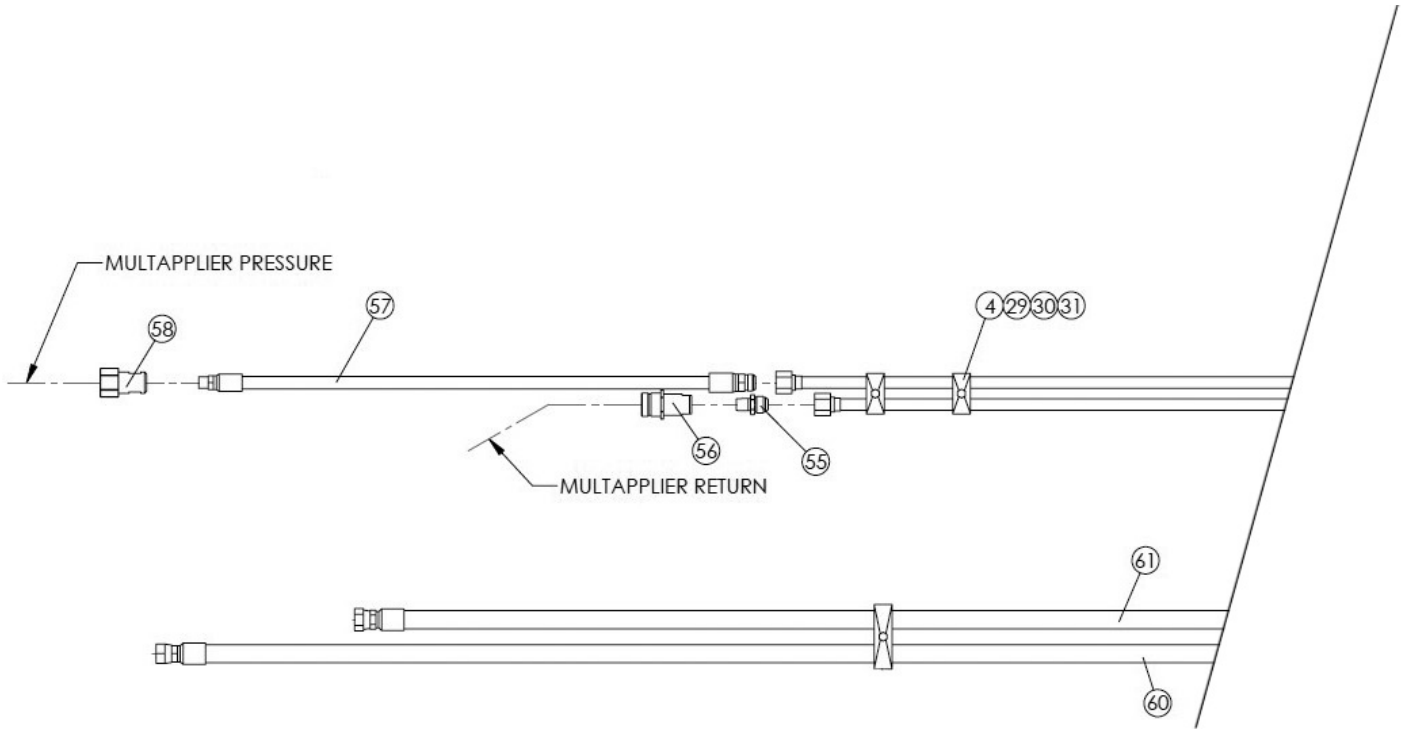

Hi Performance Hydraulics

ITEM	PART NO.	DESCRIPTION	QTY
1	305751	Tank - Group Hyd Mnt	1
	306082	Tank - Group Hyd Mnt 304	1
2	306291	Valve - Assy Sfp 25gpm 13'	1
	318192	Valve - Assy 14'	1
3	305900	Tube - Assy .75od X .065 X 84.5 304 13'	1
	305901	Tube - Assy .75od X .065 X 96.5 304 14'	1
4	75036	Clamp - Tubing Twin .75	3
5	305902	Tube - Assy .75od X .049 X 81 13'	1
	305903	Tube - Assy .75od X .049 X 93 14'	1
6	305904	Tube - Assy 1od X .083 X 88 13'	1
	305905	Tube - Assy 1od X .083 X 100 14'	1
7	300033	Clamp - Tubing Twin 1	3
8	305906	Tube - Assy 1od X .049 X 85 13'	1
	305907	Tube - Assy 1od X .049 X 97 14'	1
9	29850	Fitting - 16-16-16 070432	2
10	34849	Fitting - 16-12 070123	1
11	34709	Fitting - 12-12 070221	2
12	29785	Fitting - 12-12 070201	1
13	29783	Fitting - 16-16 070201	1
14	29806	Fitting - 16-16 070321	2
15	56424	Hose - Assy 1 X 25 100r12	1
16	29807	Fitting - 16-16 070221	1
17	29748	Hose - Assy 1 X 30 100r2	1
18	305522	Hose - Assy .75 X 36 100r12	1
19	29638	Hose - Assy .75 X 24 100r2	2
20	305910	Valve - Assy Hyd Pwm Valve	1
21	82599	Hose - Assy 1 X 42 2cb	1
22	305912	Hose - Assy 1.25 X 38.5 Return	1
23	29766	Fitting - 6-6 070102	1
24	98724	Fitting - 6-6-6 070432	1
25	34761	Fitting - Socketless .56 Jic X	1
26	34868	Fitting - 4-4 070221	1
27	306154	Hose - Assy .38 X 72 100r1	1
28	71830	Capscrew - .313-18nc X 2.5 SS	6
29	36424	Washer - Flat .313 SS	8

Hi Performance Hydraulics

<u>ITEM</u>	<u>PART NO.</u>	<u>DESCRIPTION</u>	<u>QTY</u>
30	42221	Nut - Lock .313-18nc SS	12
31	86557	Clamp - Tube 1 2pcs=1set	1
32	86556	Plate - Cover Hyd Tube Clamp	1
33	34865	Capscrew - .25-20nc X 2.25 SS	2
34	36423	Washer - Flat .25 SS	2
35	42034	Nut - Lock .25-20nc SS	4
36	302097	Washer - Step .25id X .40od X	4
37	36396	Capscrew - .25-20nc X 3 SS	2
38	306118	Bracket - Wldmt Valve Mounting	1
39	42639	Bolt - Carriage .313-18nc X 1	2
40	29840	Fitting - 16-16 070220	1
41	302397	Bracket - Valve Mount 304	1
42	42794	Capscrew - .313-18nc X 3.75 SS	4
43	36398	Capscrew - .375-16nc X 1 SS	3
44	36425	Washer - Flat .375 SS	3
45	72054	Nut - Lock .375-16nc SS	3
62	34195-48	Hose - .375 X 48	1
65	34719	Fitting - 16-16 070101	1
66	302160-AA	Valve - Check 3/4 Charted	1

Hydraulic Reservoir w/Cooler

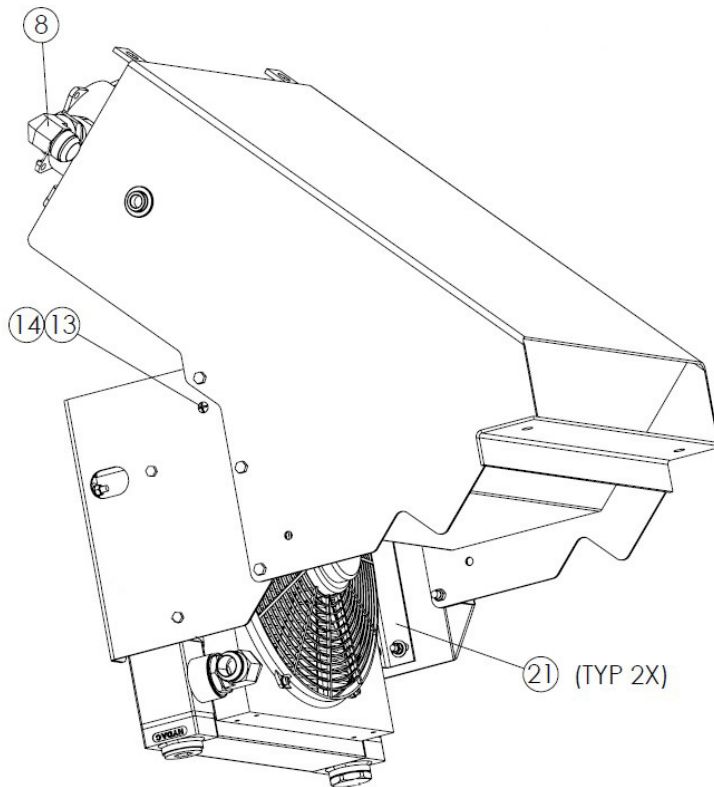
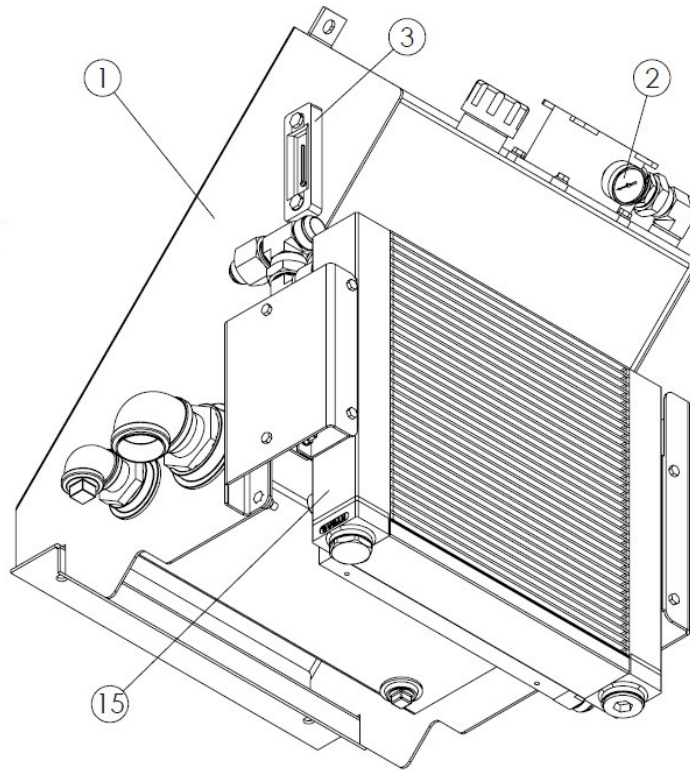

Hydraulic Reservoir w/Cooler

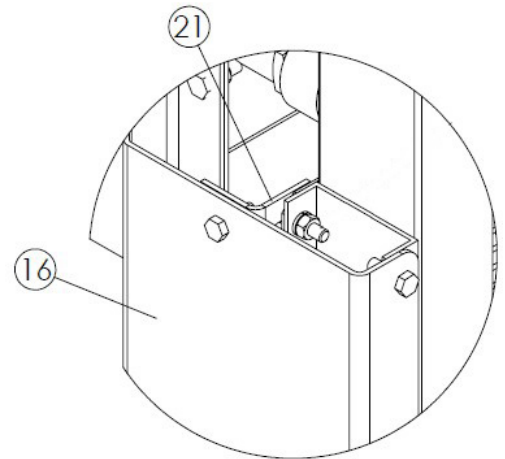
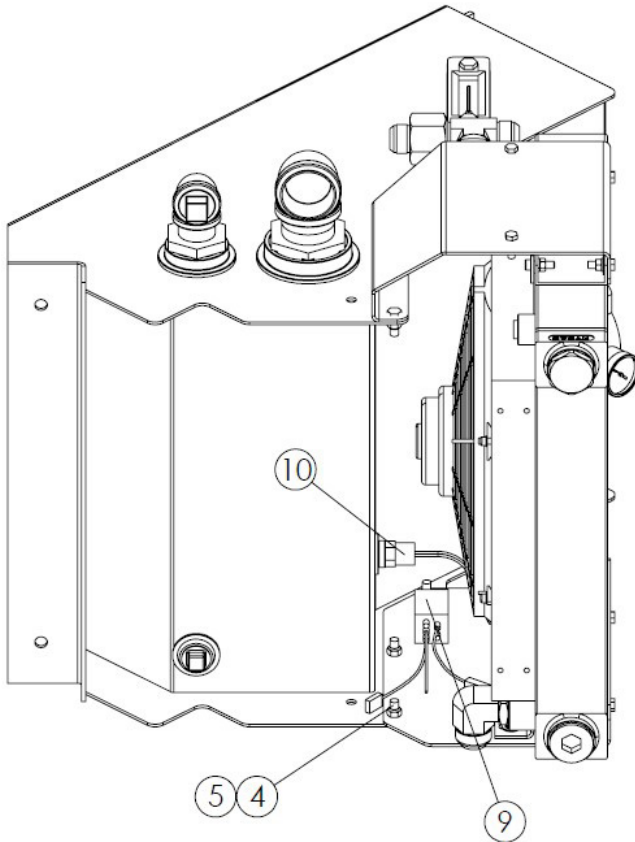
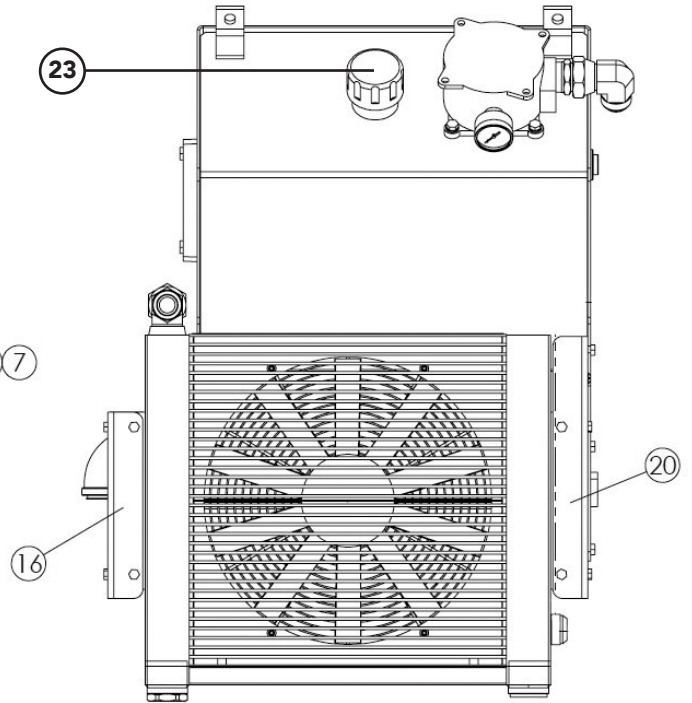
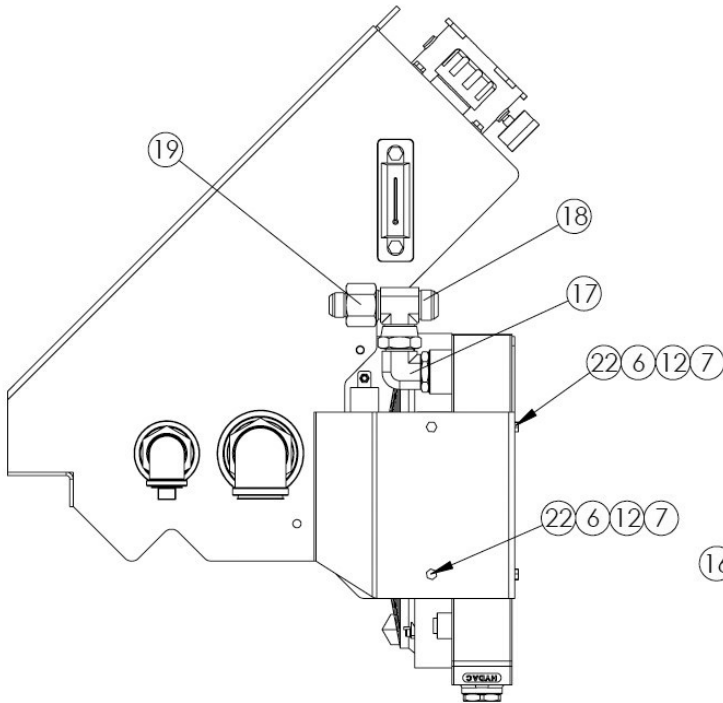

Hydraulic Reservoir w/Cooler

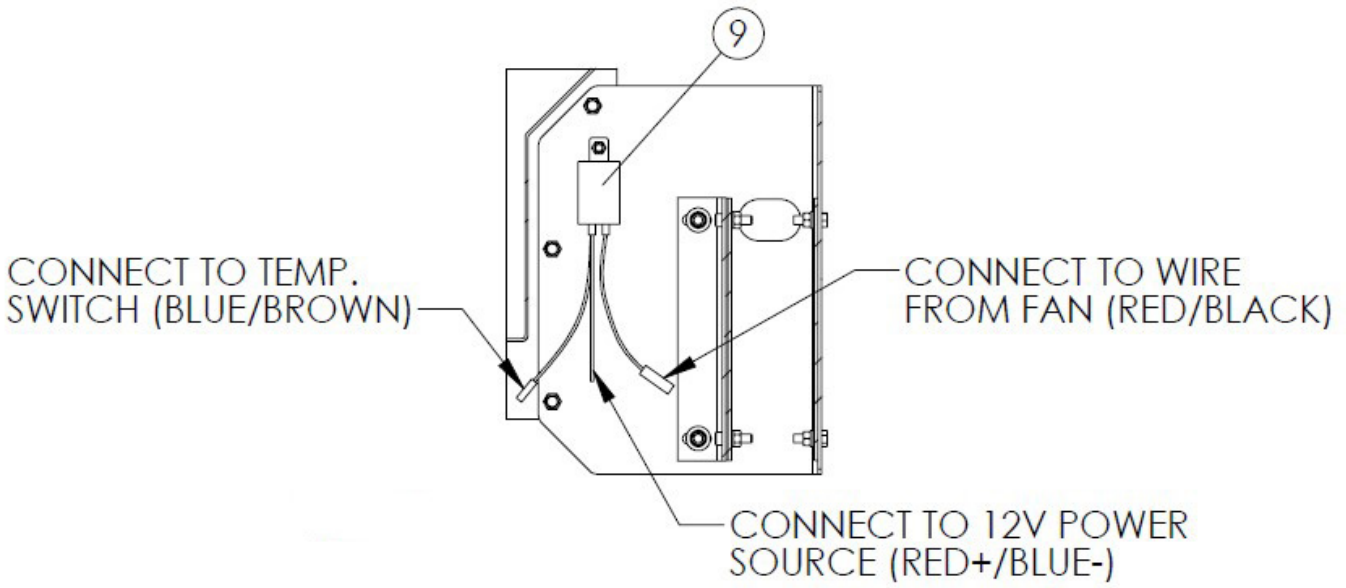

Hydraulic Reservoir w/Cooler

<u>ITEM</u>	<u>PART NO.</u>	<u>DESCRIPTION</u>	<u>QTY</u>
1	305054	Hydraulic Reservoir Assy	1
	306080	Hydraulic Reservoir Assy 304	1
2	43534	Indicator - Service Gauge	1
3	38575	Gauge - Sight & Temperature	1
4	36398	Capscrew - .375-16nc X 1 SS	5
5	72054	Nut - Lock .375-16nc SS	5
6	36424	Washer - Flat .313 SS	8
7	36413	Nut - Hex .313-18nc SS	8
8	98568	Fitting - 20-20 070221	1
9	96750-X1	Relay - 12vdc 40a	1
10	305074	Switch - Temperature 114°	1
11	*98662	Hose - Assy 1.25od X 48 2cb	1
12	36419	Washer - Lock .313 SS	8
13	56258	Screw - Truss Head .25-20nc	1
14	42034	Nut - Lock .25-20nc SS	1
15	305767	Cooler - Assy 72gpm Hydac	1
16	305761	Bracket - Cooler Lh 304	1
17	96916	Fitting - 20-20 070220	2
18	56267	Fitting - 20-20-20 070433	1
19	34819	Fitting - 20-16 070123	1
20	305760	Bracket - Cooler Rh 304	1
21	306447	Bracket - Cooler Mount 304	2
22	34580	Capscrew - .313-18nc X 1 SS	8
23	96747	Filler - Weld In Neck	1
-	320410	Filler - Cap Breather	1

* - Not Shown

Hydraulic Reservoir

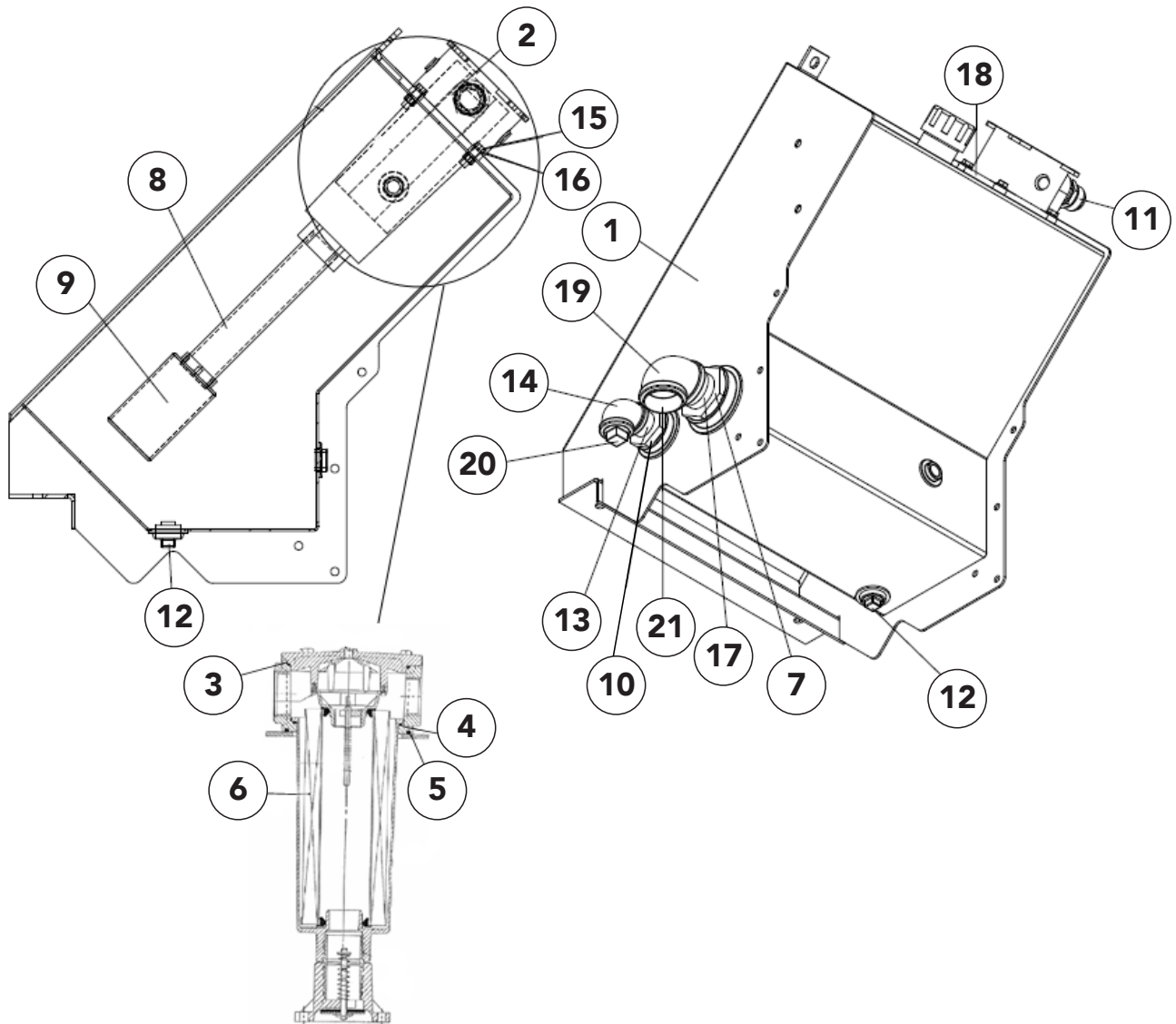

Hydraulic Reservoir

<u>ITEM</u>	<u>PART NO.</u>	<u>DESCRIPTION</u>	<u>QTY</u>
	CS 304 SS		
	305054 306080	Hydraulic Reservoir Assy, Includes Items 1 - 21	1
1	305050 306074	Reservoir – Hydraulic Wldmt	1
2	88838 88838	Filter – Return, Includes 3-6	1
3	306772 306772	O-Ring - Cover Filter	1
4	306773 306773	O - Ring - Housing Filter	1
5	306789 306789	Seal - Filter Assy	1
6	305066 305066	Element - Filter	1
7	305063 305063	Strainer – 2 NPT	1
8	305058 305058	Pipe – 1.5 SCH40 10	1
9	305057 305057	Diffuser – Tank	1
10	305062 305062	Strainer – 1-1/4 NPT	1
11	29768 29768	Fitting – 20-20 070102	1
12	305061 305061	Plug – Magnetic 1 NPT	1
13	6028 6028	Nipple - Close 1-1/4 NPT	1
14	6011 6011	Elbow 90° 1-1/4 NPT	1
15	36399 36399	Cap Screw – 3/8-16 x 1-1/4	4
16	36420 36420	Washer – Lock 3/8	4
17	22324 22324	Nipple - Close 2 NPT STD	1
18	306186 306186	Gasket Maker - Silicone	1
19	23703 23703	Adapter - Elbow 90° 2 NPT	1
20	6035 6035	Plug - Pipe 1-1/4 NPT	1
21	306301 306301	Plug - Tapered 2 NPT	1

Hydraulic Cooler

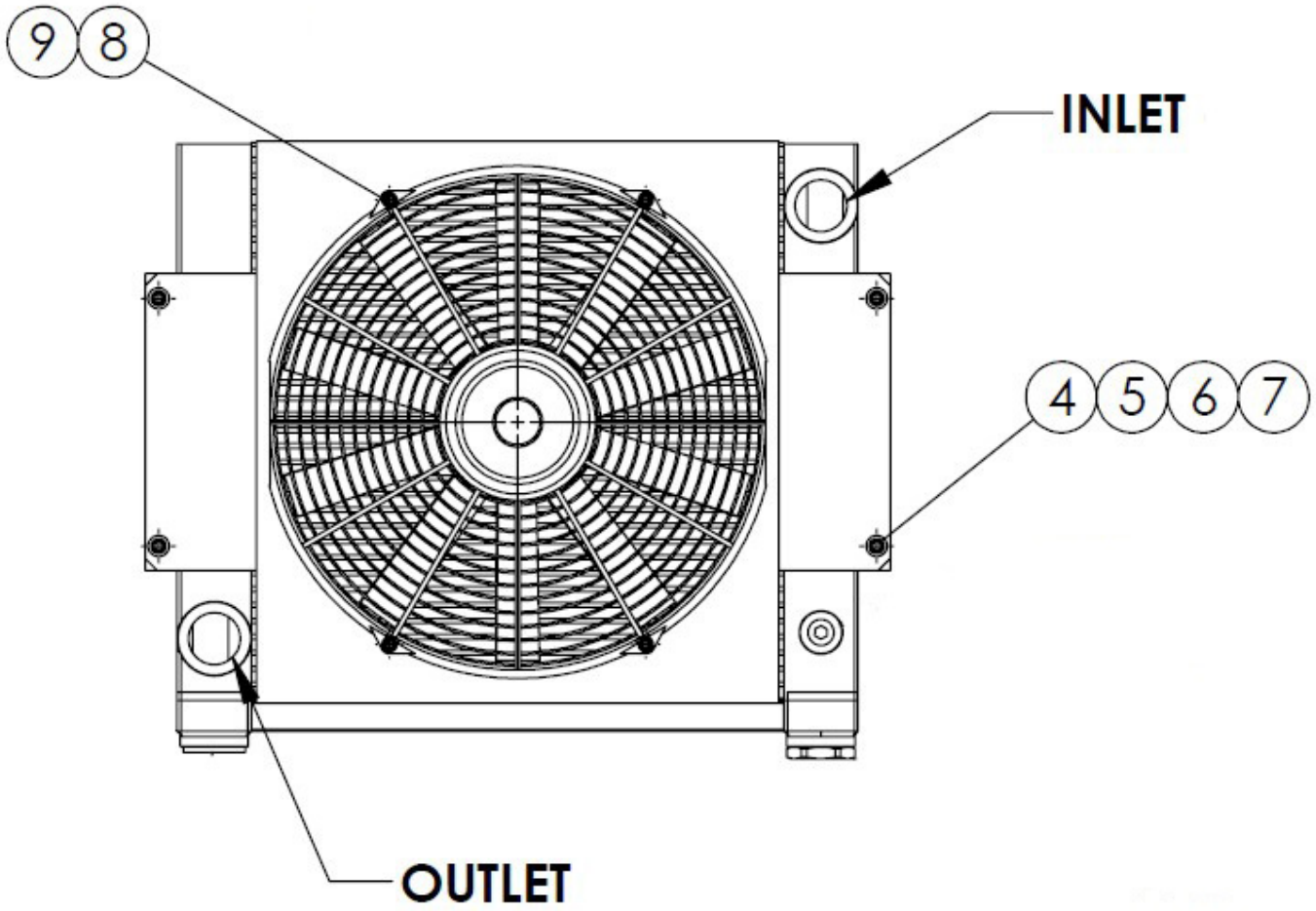

Hydraulic Cooler

<u>ITEM</u>	<u>PART NO.</u>	<u>DESCRIPTION</u>	<u>QTY</u>
1	*305767-AA	Core - Cooler	0
2	*305767-AB	Fan - Assy Cooler	0
3	*305767-AC	Housing - Cooler	0
4	319927	Screw - Sockethead .313-18nc	4
5	319928	Washer - Lock M6	4
6	319929	Screw - Sockethead M6-1 X 20	4
7	20711	Washer - Lock .313 Zn	4
8	20677	Nut - Lock .313-18nc Zn	4
9	20692	Washer - Flat .313 Zn	8

* - Not Shown

Standard Hydraulics - 4.38 CID Pump

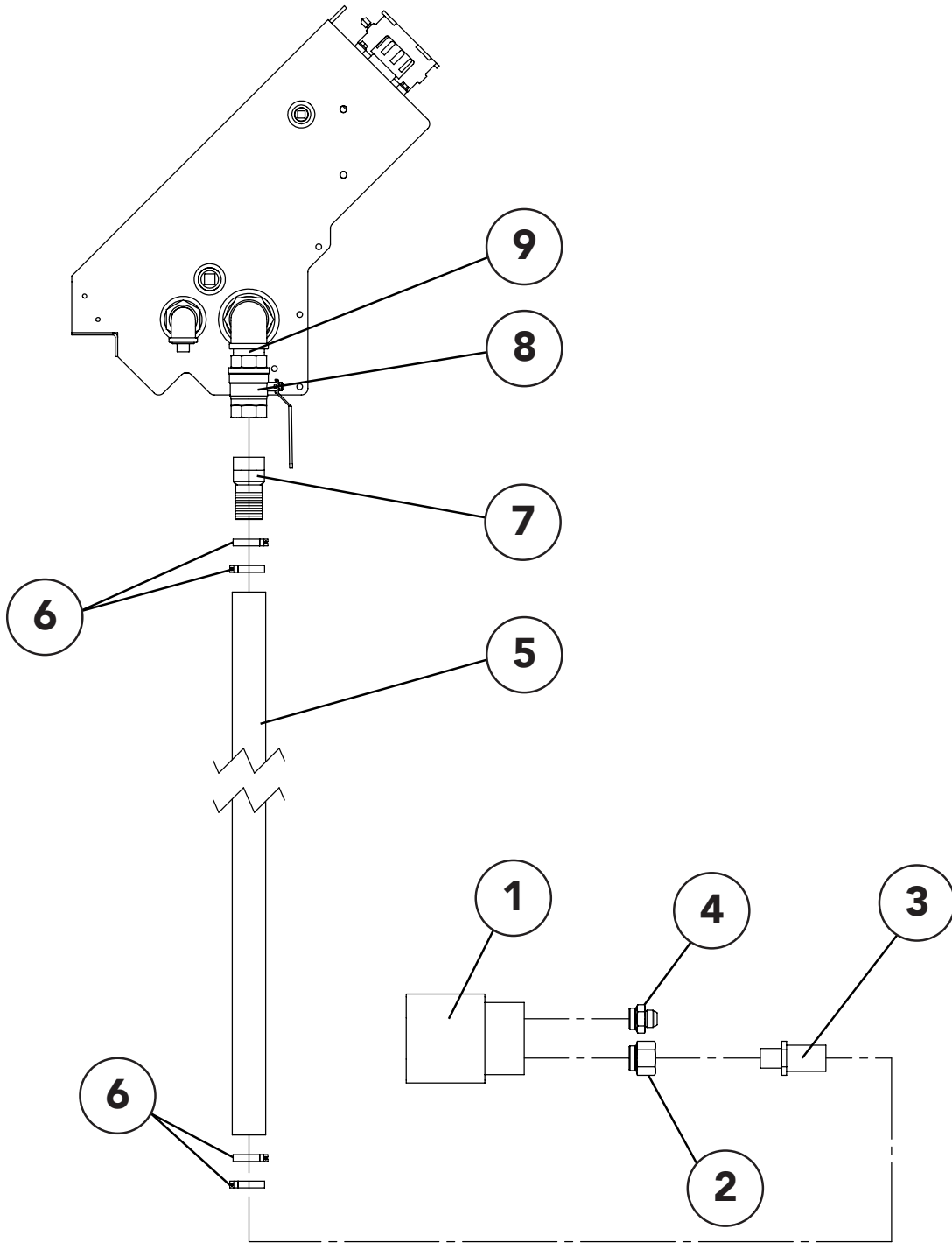

Standard Hydraulics - 4.38 CID Pump

<u>ITEM</u>	<u>PART NO.</u>	<u>DESCRIPTION</u>	<u>QTY</u>
1	86665	Pump - 4.38 CID Hydraulic Direct Mount	1
2	29780	Fitting - 1-7/8 - 12 SAE x 1-1/2 NPT	1
3	96654	Fitting - Hose End 1-1/2 NPT x 2" Hose	1
4	34845	Adapter	1
5	32401-108	Hose - Suction 2" x 108"	1
6	22380	Clamp - Hose	1
7	29811	Fitting - Hose End	1
8	305060	Valve - Ball 2"	1
9	22324	Nipple - 2 NPT	1

Standard Hydraulics - 4.46 CID Tandem Pump

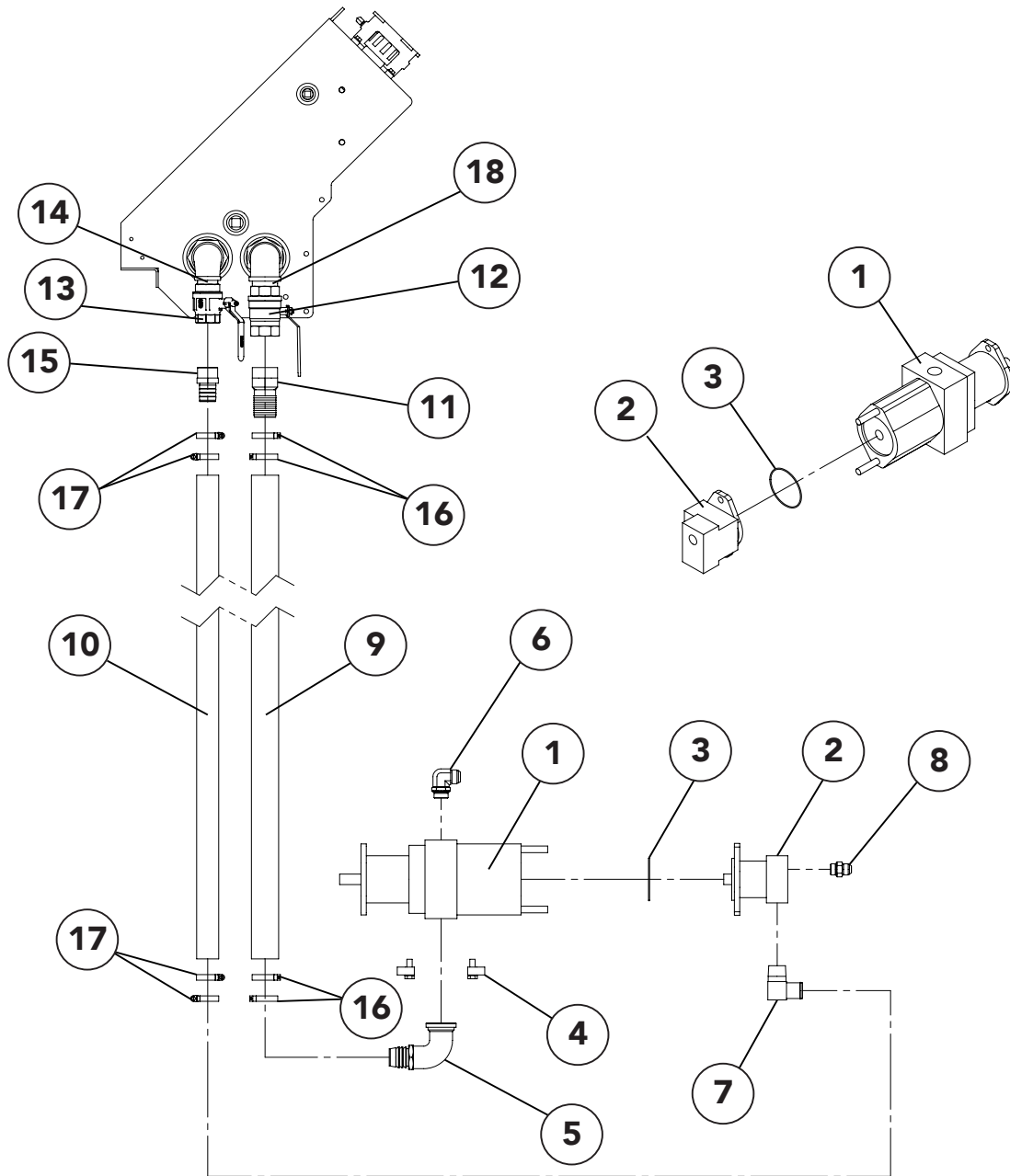

Standard Hydraulics - 4.46 CID Tandem Pump

<u>ITEM</u>	<u>PART NO.</u>	<u>DESCRIPTION</u>	<u>QTY</u>
1	304424	Pump - 4.46 CID Hydraulic (Front section)	1
	* 300493	Gasket – Paper Pump	1
	* 300492	Cover – Pump Rear	1
2	304425	Pump – .93 CID (Rear section)	AR
3	300669	O-Ring – 4” ID	AR
4	41015	Kit – Flange Split -32	1
5	34806	Fitting – 32-32 12151-3-E90S-L	1
6	29840	Adapter – Elbow 90°	1
7	304427	Fitting – 20-20 430260	AR
8	29789	Fitting – 12-12 070120	AR
9	32401-108	Hose – Suction 2” x 108”	1
10	23184-108	Hose – Suction 1-1/4”	AR
11	29811	Fitting – Hose End	1
12	305060	Valve – Ball 2”	1
13	305059	Valve – Ball 1-1/4”	AR
14	6028	Nipple - 1-1/4 NPT	AR
15	16582	Fitting – Hose Barb	AR
16	22380	Clamp – Hose	4
17	6335	Clamp – Hose	AR
18	22324	Nipple - 2 NPT	1

AR - As Required

* - Not Shown – Use when .93 CID pump add-on not installed on 4.46 CID pump

Hi Performance Pump Hydraulics

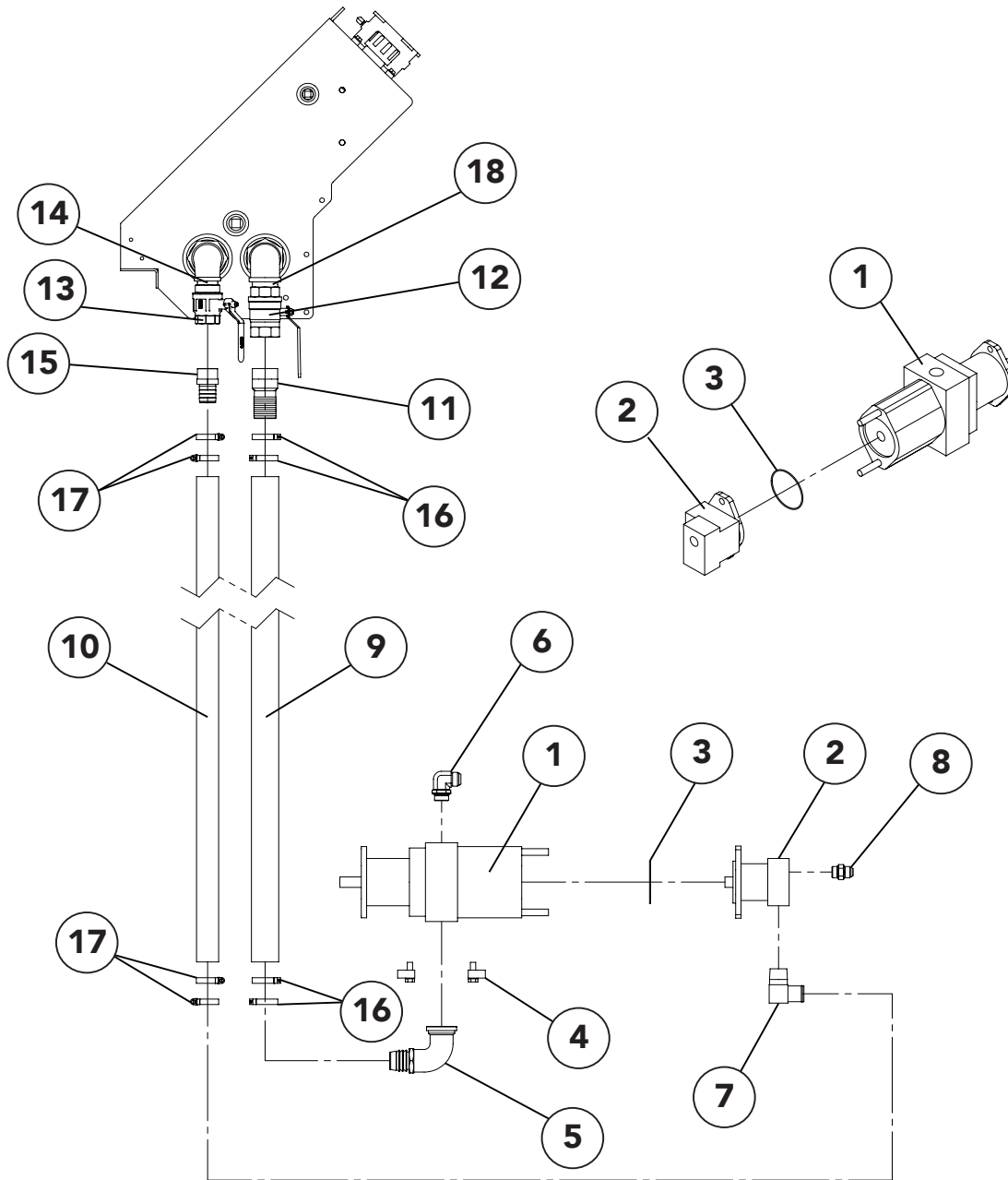

Hi Performance Pump Hydraulics

<u>ITEM</u>	<u>PART NO.</u>	<u>DESCRIPTION</u>	<u>QTY</u>
1	304424	Pump - 4.46 CID Hydraulic Direct Mount	1
2	304426	Add-on Pump - 2.17 CID	1
3	300669	O-Ring - 4" ID	1
4	41015	Kit - Flange Split -32	1
5	34806	Fitting - 32-32 12151-3-E90S-L	1
6	29840	Adapter - Elbow 90°	1
7	312904	Fitting - 24-20 430260	1
8	29789	Adapter	1
9	32401-108	Hose - Suction 2" x 108"	1
10	21878-108	Hose - Suction 1-1/2" x 108"	1
11	29811	Fitting - Hose End	2
12	305060	Valve - Ball 2"	1
13	310404	Valve - Ball 1-1/2"	1
14	22322	Nipple - 1-1/2 NPT	1
15	31680	End - Hose 1-1/2 NPT x 1-1/2" Hose	1
16	22380	Clamp - Hose	4
17	6288	Clamp - Hose	4
18	22324	Nipple - 2 NPT	1

Assembly

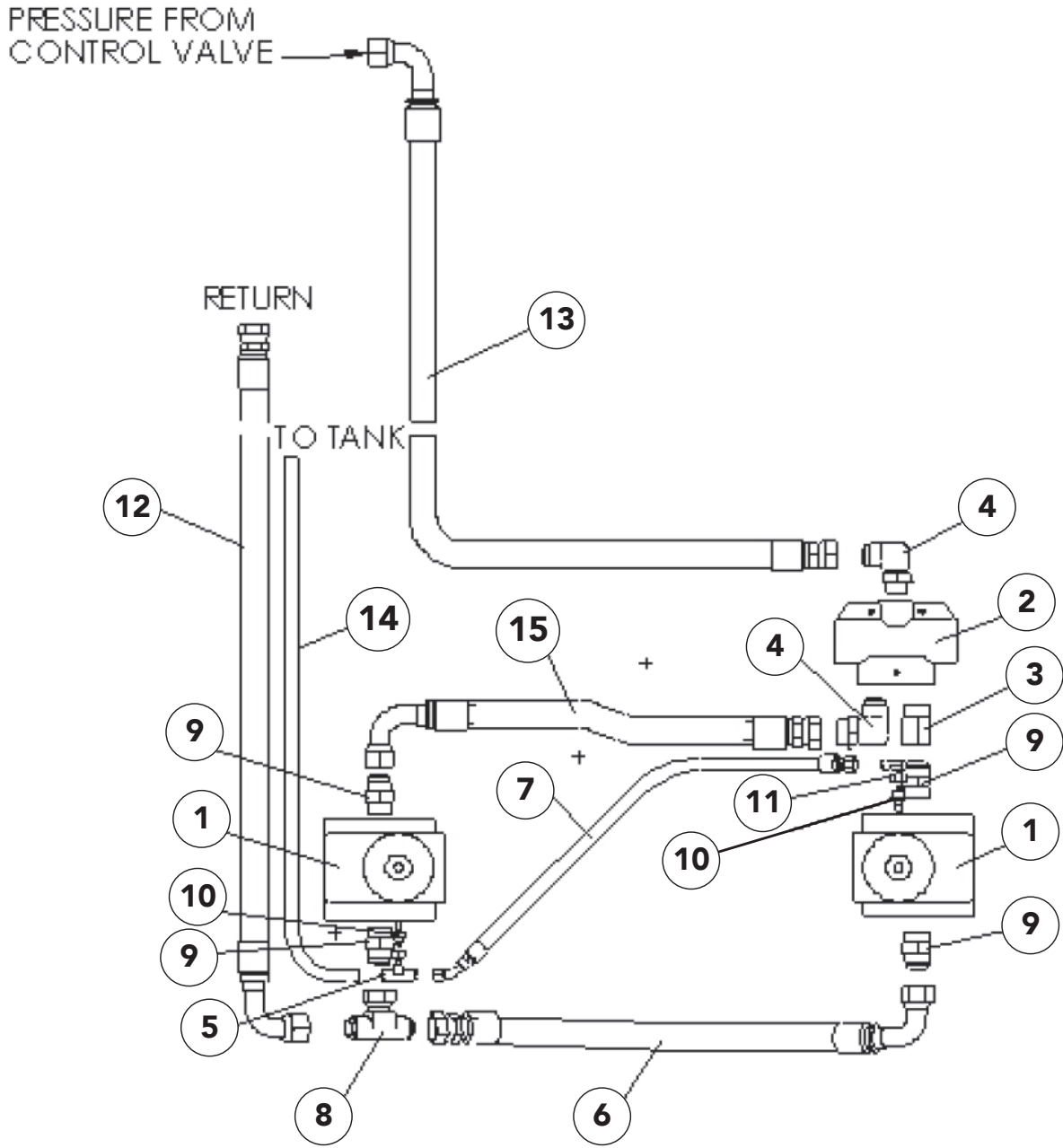

Assembly

<u>ITEM</u>	<u>PART NO.</u>	<u>DESCRIPTION</u>	<u>QTY</u>
	305948	Motor - Assy LH Style II, Includes 1,5,8-10	
	305949	Motor - Assy RH Style II, Includes 1,9-11	
1	313512	Motor - Spinner 5.1 CID (Post-2016 Units)	2
	305950	Motor-Spinner Style II (2016 & Previous units)	2
	72548	Seal Kit	AR
	305824	Seal Kit - Retainer	AR
2	71781	Valve – Flow Divider	1
3	34810	Adapter	1
4	29840	Adapter - 90°	2
5	29825	Tee – Swivel Nut	1
6	87111	Hose Assy	1
7	87112	Hose Assy	1
8	29836	Tee – Swivel Nut	1
9	29803	Adapter	4
10	34763	Adapter	2
11	34816	Adapter - 90° 1	1
12	87113	Hose – Return Assy	1
13	98102	Hose – Pressure Assy	1
14	83601	Hose – 13’ Unit Drain Line	1
	83602	Hose – 14’ Unit Drain Line	1
15	98101	Hose Assy	1

Spinner Control Valve - Style B

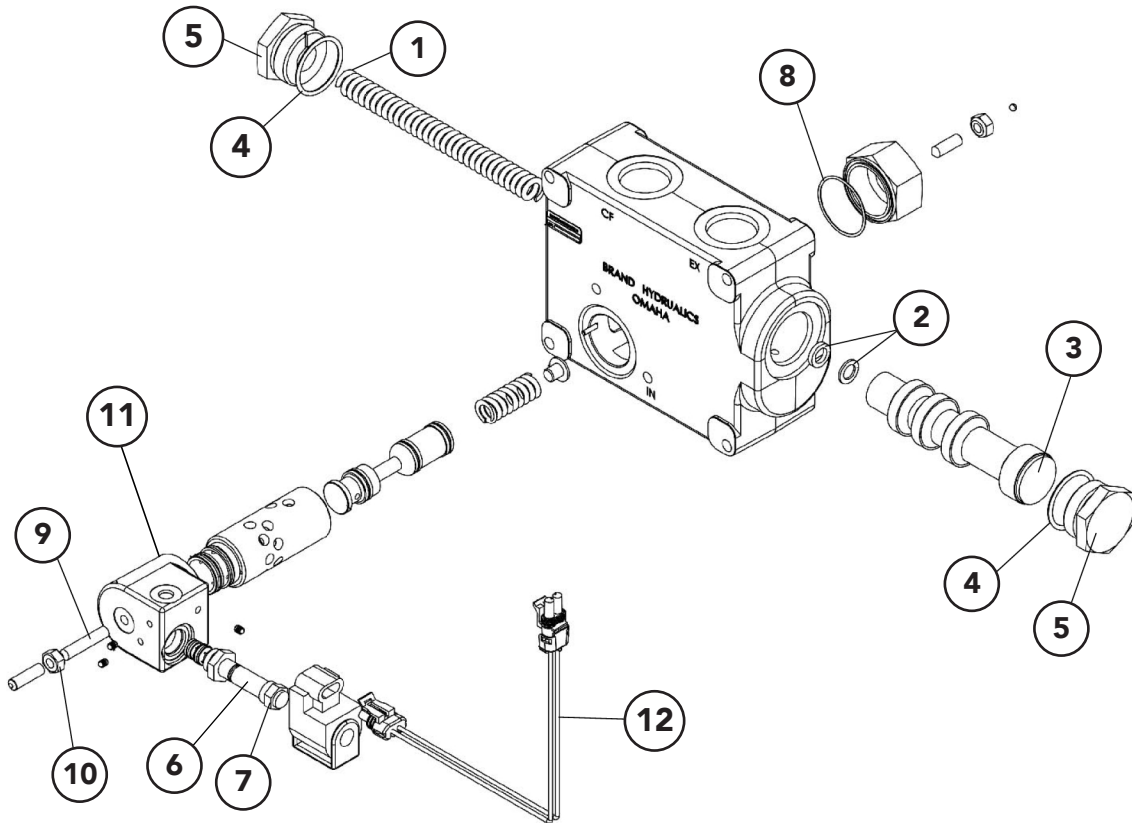

Spinner Control Valve - Style B

<u>ITEM</u>	<u>PART NO.</u>	<u>DESCRIPTION</u>	<u>QTY</u>
	38576-X4	Valve - Flow Control Electric Actuated	1
1	53960	Spring	1
2	90696	Shim	2
3	90697	Spool	1
4	90698	O-Ring	1
5	90699	Plug	2
6	38576-AA	Cartridge	1
7	38576-AG	Nut - Cartridge	1
8	38576-AC	O-Ring	1
9	38576-AD	Screw - Set	1
10	38576-AE	Nut - Jam	1
11	38576-AF	Cartridge Valve Body	1
12	38576-AI	Cable Assy	1
13	*38576-AH	Valve - Kit Seal	1
14	**38576-BA	Kit - Pilot Conversion Use to convert Style B valve to Style A	AR

* - Not Shown AR - As Required

#3 PintleChain Conveyor

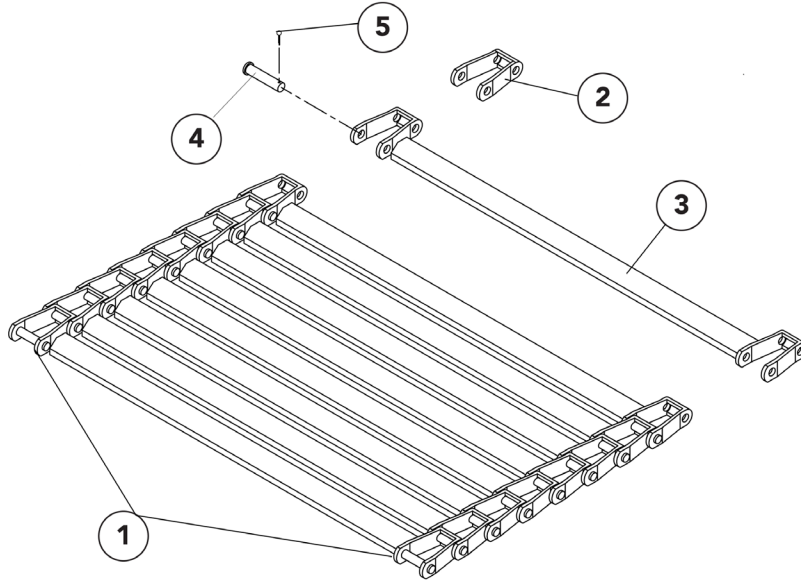

<u>ITEM</u>	<u>PART NO.</u>	<u>DESCRIPTION</u>	<u>QTY</u>
1	97091	#3 Pintle Chain – 13’ Unit Assy	1
	97092	#3 Pintle Chain – 14’ Unit Assy	1
2	36699	Link - Pintle Chain	AR
3	88857	Bar - Cross Wldmt	AR
4	36697	Pin - Pintle Chain	AR
5	20817	Pin - Cotter	AR

Conveyor

#4 Belt-Over-Chain Conveyor

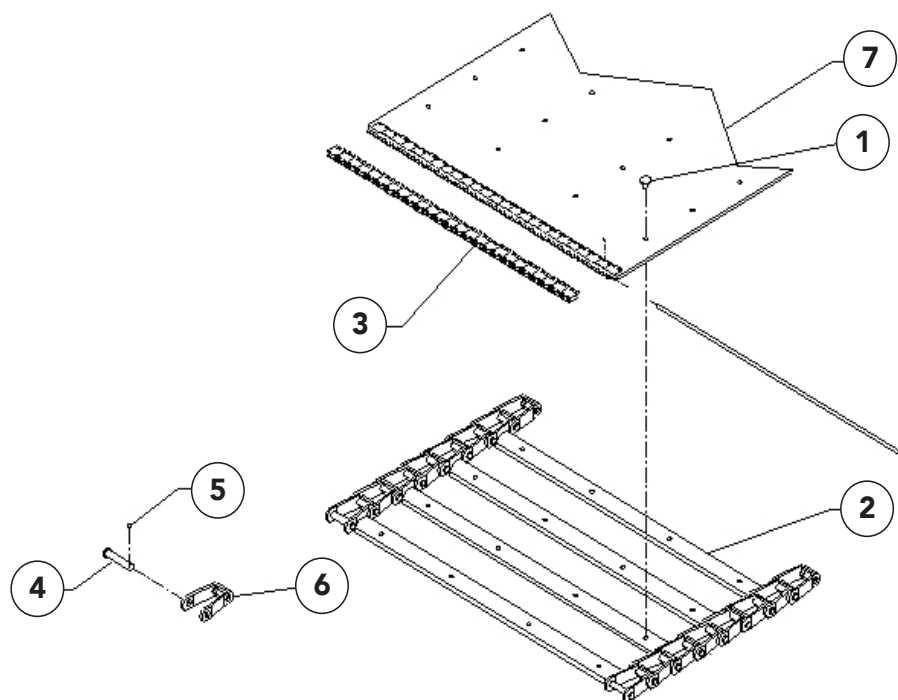

ITEM	PART NO.	DESCRIPTION	QTY
	305614-AG	Belt-Over-Chain - #4 13' MOR	1
	305614-AH	Belt-Over-Chain - #4 14' MOR	1
1	305646	Screw - #4BOC 1/4 x 9/16 torx Flat Head	AR
2	305643	Crossbar	AR
3	73317	Kit - Splicer	1
		Lacing Strips 23"	2
	56405	Pin - Connecting	1
		Staples	AR
4	36697	Pin - Pintle Chain	AR
5	20817	Pin - Cotter	AR
6	36699	Link - Pintle Chain	AR
7	56377-AB	Belt - Conveyor	AR

Conveyor Chain Shields

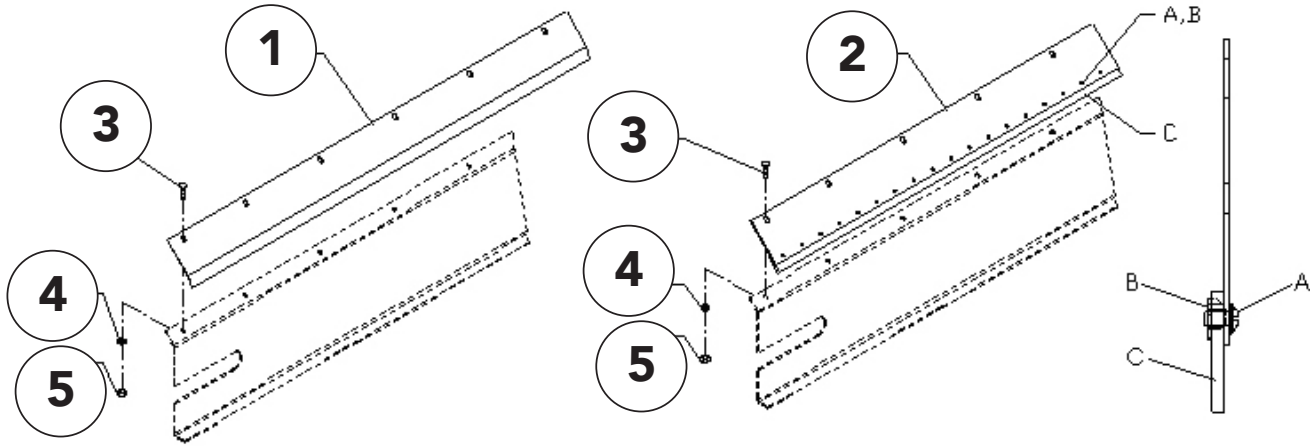

Conveyor

Conveyor Chain Shields

<u>ITEM</u>	<u>PART NO.</u>	<u>DESCRIPTION</u>	<u>QTY</u>
	<u>409 SS</u>	<u>304 SS</u>	
1		Chain Shield – #3 Chain	
	97732-AB	97749-AB	13' Unit
	97732-AC	97749-AC	14' Unit
2		Chain Shield – #4 Chain	
	97836	97854	13' Unit
	97837	97855	14' Unit
A	56258	56258	Screw – Truss Head 1/4 x 1/2
B	88931	88931	Nut – Tee 1/4 x 1/4
C	305975	305975	Sealer - Belt, #4 BOC Shield
		(Specify Unit Length)	
3	71829	71829	Bolt – Carriage 3/8 x 1
4	36420	36420	Washer – Lock 3/8
5	36414	36414	Nut – Hex 3/8

Conveyor Idler

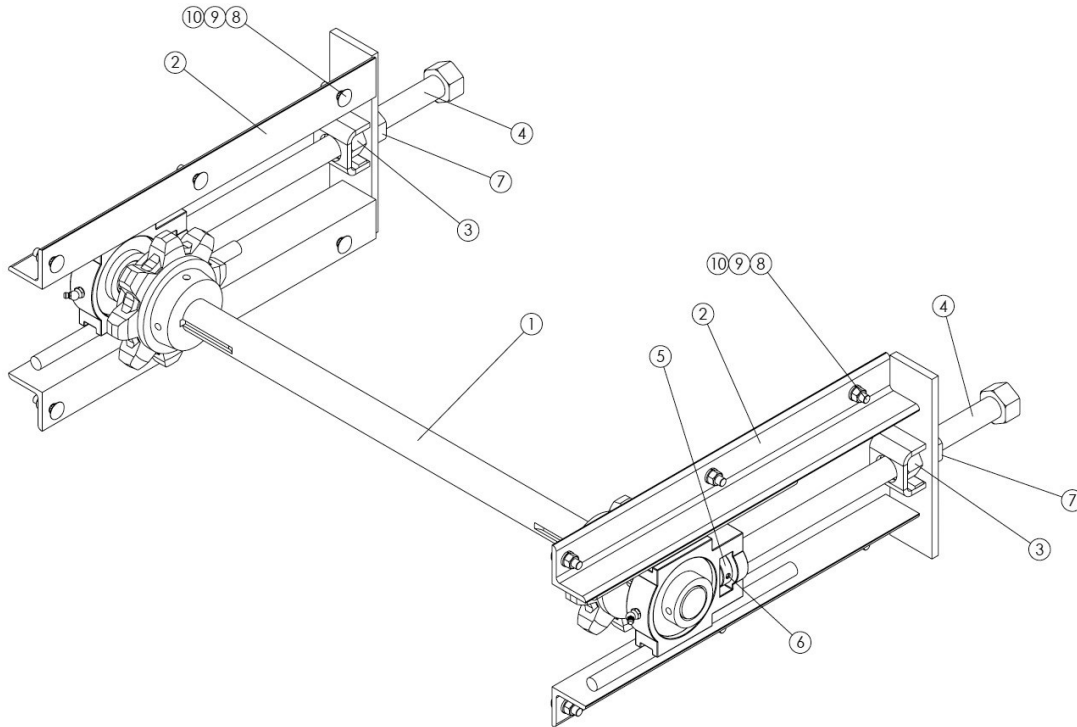

Conveyor**Conveyor Idler**

<u>ITEM</u>	<u>PART NO.</u>	<u>DESCRIPTION</u>	<u>QTY</u>
1	97053	Shaft - Assy Idler 30 Conv	1
2	7895	Take Up - Wldmt	2
	79321	Take Up - Wldmt SS	2
3	39110	Nut - Wldmt SS	2
4	36508	Screw - Wldmt Adjusting SS	2
5	30725	Collar - 1 Pin Hole	2
6	20925	Pin - Roll .25 X 1.5 Zn	2
7	36509	Nut - Hex 1-8nc SS	2
8	36408	Bolt - Carriage .375-16nc X 1	12
	36409	Bolt - Carriage .375-16nc X 1.25 SS	12
9	36420	Washer - Lock .375 SS	12
10	36414	Nut - Hex .375-16nc SS	12

Conveyor Drive

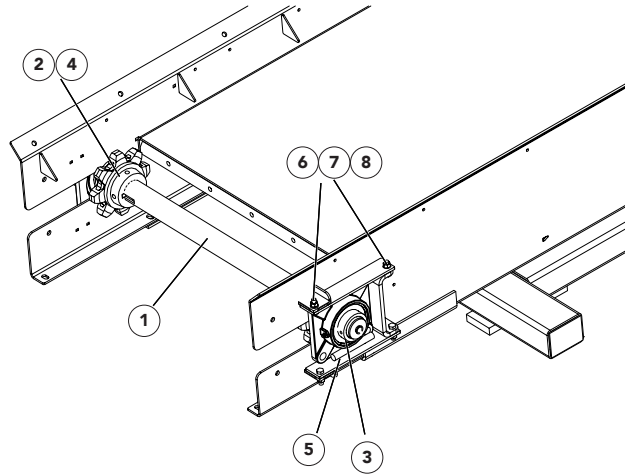
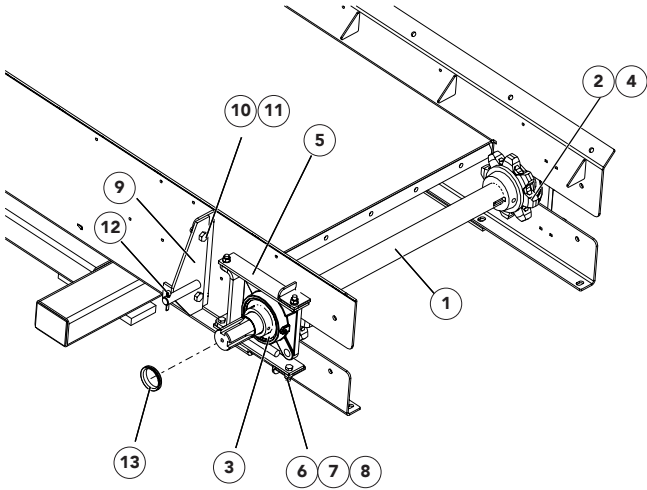

Conveyor**Conveyor Drive**

<u>ITEM</u>	<u>PART NO.</u>	<u>DESCRIPTION</u>	<u>QTY</u>
	97052	Shaft - Drive Assy, Includes Items 1 - 5	
1	310606	Shaft – Drive	1
2	88276	Sprocket	2
	20743	Screw – Set 5/16 x 3/8	1
3	6465	Bearing	2
4	6131	Key – Square 3/8 x 1 1/2	2
5	56264	Cap/Plug - Plastic	1
6	82885	Guide – Bearing	4
7	36399	Cap Screw - 3/8 x 1 1/4	8
8	36420	Washer – Lock 3/8	8
9	36414	Nut – Hex 3/8	8
10	82552	Bracket – Torque Arm LH	1
11	20128	Cap Screw - 1/2 x 1 1/4	2
12	20680	Nut – Lock 1/2	2
13	20833	Pin – Cotter 1/4 x 1 1/2	1
14	311172	V-Ring Seal	1

* Not Shown

Gearcase - Dual Pinion Assembly Standard Hydraulics

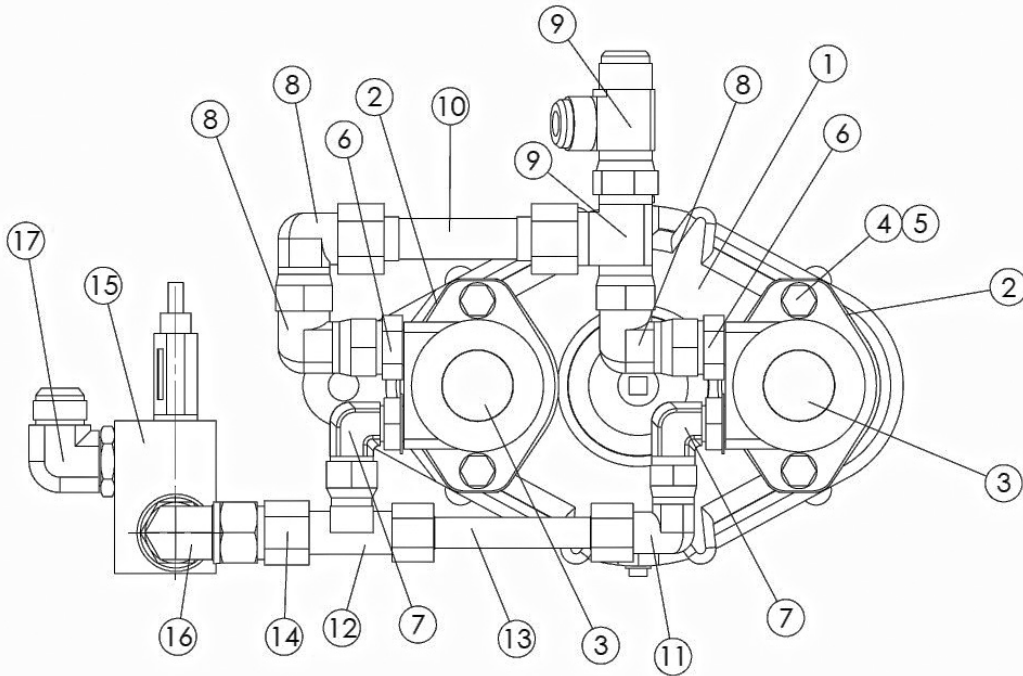

ITEM	PART NO.	DESCRIPTION	QTY
1	37985	Gearcase - 6:1	1
2	74524	Gasket - SAE 101-2	2
3	82459	Motor - Hydraulic 14.1 CID	2
	39137	Seal Kit - Motor	2
4	20129	Cap Screw - 1/2-13 NC x 1-1/4	4
5	20714	Washer - Lock 1/2	4
6	29778	Adapter - Reducing	2
7	29773	Adapter - Elbow	2
8	29807	Adapter - Elbow	3
9	29850	Tee - Swivel Nut	2
10	80888	Tube Assy - 1" OD x 2-15/16"	1
11	34709	Adapter - Elbow	1
12	29809	Adapter - Tee Branch	1
13	80886	Tube - 3/4" x 4-7/8"	1
14	34712	Adapter - Bushing	1
15	304818	Valve - Dump relief 2050 PSI	1
16	304819	Fitting - 16-16 Non Standard 90	1
17	29840	Fitting - 16-16 070220	2

Conveyor

Gearcase - Dual Pinion Assembly Hi Performance Hydraulics

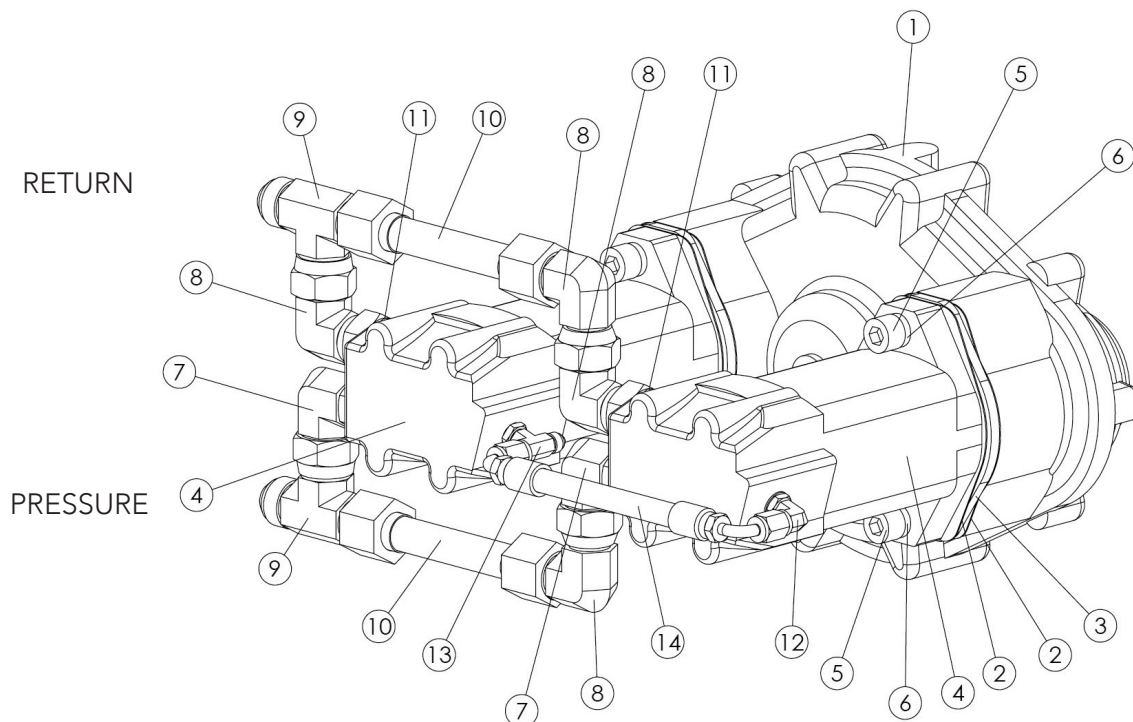

ITEM	PART NO.	DESCRIPTION	QTY
1	37985	Gearcase - 6:1	1
2	74524	Gasket	4
3	34650	Spacer	2
4	56261	Motor- Hydraulic 2000 Series 6.2 CID	2
5	305098	Cap Screw - Sockethead - 1/2-13 NC x 1-3/4	4
6	30227	Washer - Lock 1/2	4
7	29773	Fitting - 12-12 070220	2
8	34709	Fitting - 12-12 070221	4
9	29809	Fitting - 12-12-12 070433	2
10	98707	Tube - 3/4" OD x 4-7/8"	2
11	29753	Fitting - 12-12 070120	2
12	29795	Fitting - 4-4 070220	1
13	34700	Fitting - 4-4-4 070429	1
14	98760	Hose - 1/4" x 7-13/16" Drain	1

This page is intentionally left blank.

Conveyor

Gear Case Breather Tube

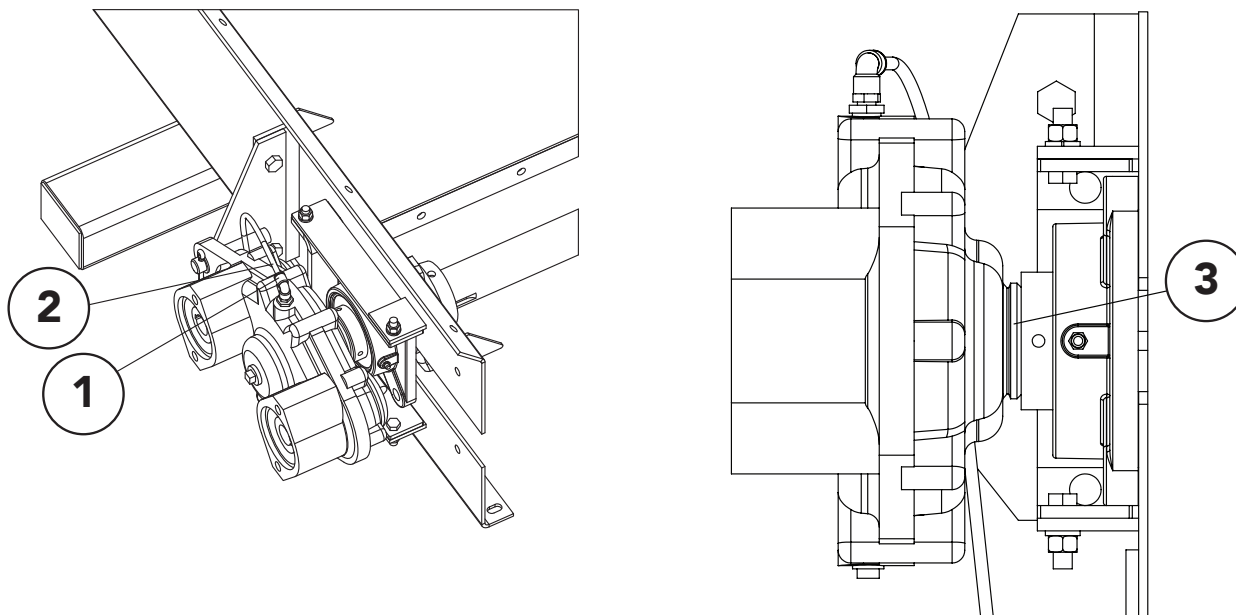

<u>ITEM</u>	<u>PART NO.</u>	<u>DESCRIPTION</u>	<u>QTY</u>
1	306891	Fitting - 4-2 630202K	1
2	9005-0-7761	Tubing - 1/4" OD Air Brake Black	1.5 ft
3	311172	V-Ring Seal	1

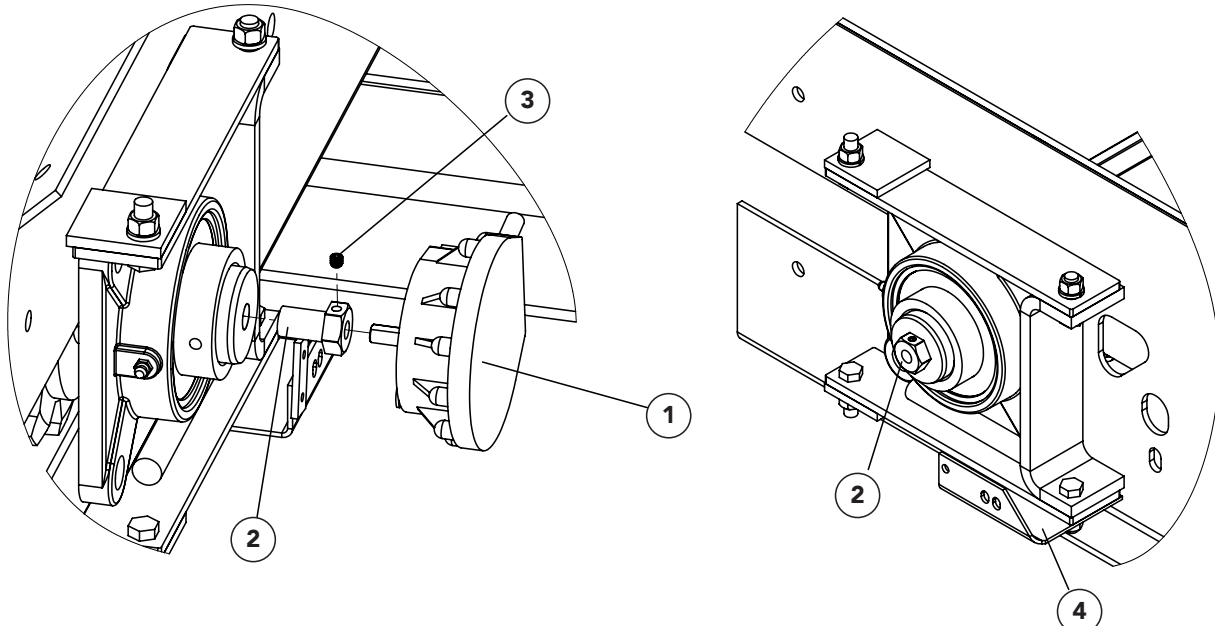

<u>ITEM</u>	<u>PART NO.</u>	<u>DESCRIPTION</u>	<u>QTY</u>
1	303994	Encoder – 180 with Hardware	1
2	310601	Coupler - Rate Sensor SS	1
3	310603	Screw - Set 1/4-20NC x 5/16 SS	1
4	304946	Bracket - Sensor, Drive Mount	1

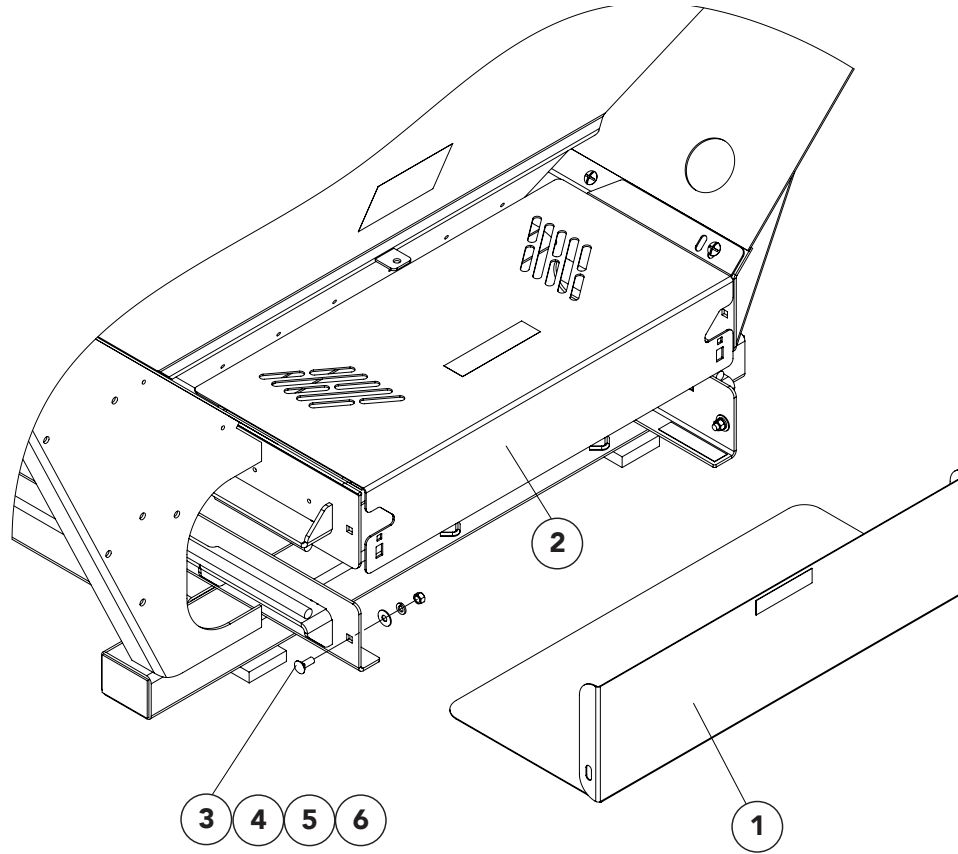

<u>ITEM</u>	<u>PART NO.</u>	<u>DESCRIPTION</u>	<u>QTY</u>
1	308860	Guard - Front Bottom	1
2	311518	Guard - Front Top	1
3	36408	Bolt - Carriage 3/8-16NC x 1 SS	2
4	36425	Washer - Flat 3/8 SS	2
5	36420	Washer - Lock 3/8 SS	2
6	36414	Nut - Hex 3/8-16NC SS	2

Conveyor Chain Oiler

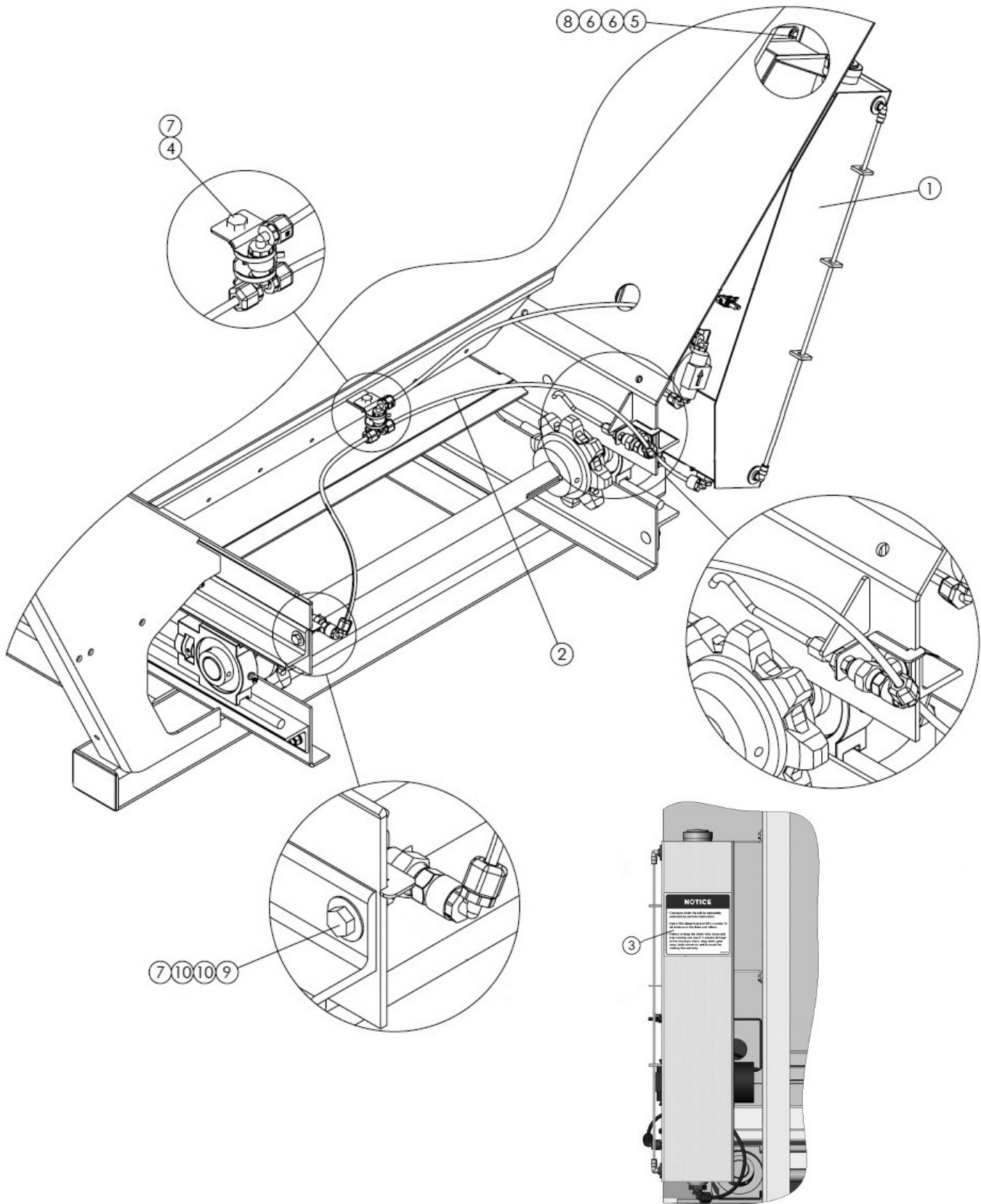

Conveyor**Conveyor Chain Oiler**

<u>ITEM</u>	<u>PART NO.</u>	<u>DESCRIPTION</u>	<u>QTY</u>
	314231	Oiler - Group Conveyor Chain	
1	310760	Tank - Assy Oiler 30 Btm W/45°	1
2	314232	Nozzle - Assy Hose	1
3	36293	Capscrew - .375-16nc X .75 SS	1
4	36393	Capscrew - .25-20nc X .75 SS	4
5	36423	Washer - Flat .25 SS	8
6	72054	Nut - Lock .375-16nc SS	3
7	42034	Nut - Lock .25-20nc SS	4
8	21476	Decal - Notice Conv Chain Life	1
9	36399	Capscrew - .375-16nc X 1.25 SS	2
10	36425	Washer - Flat .375 SS	4

Conveyor Chain Oiler

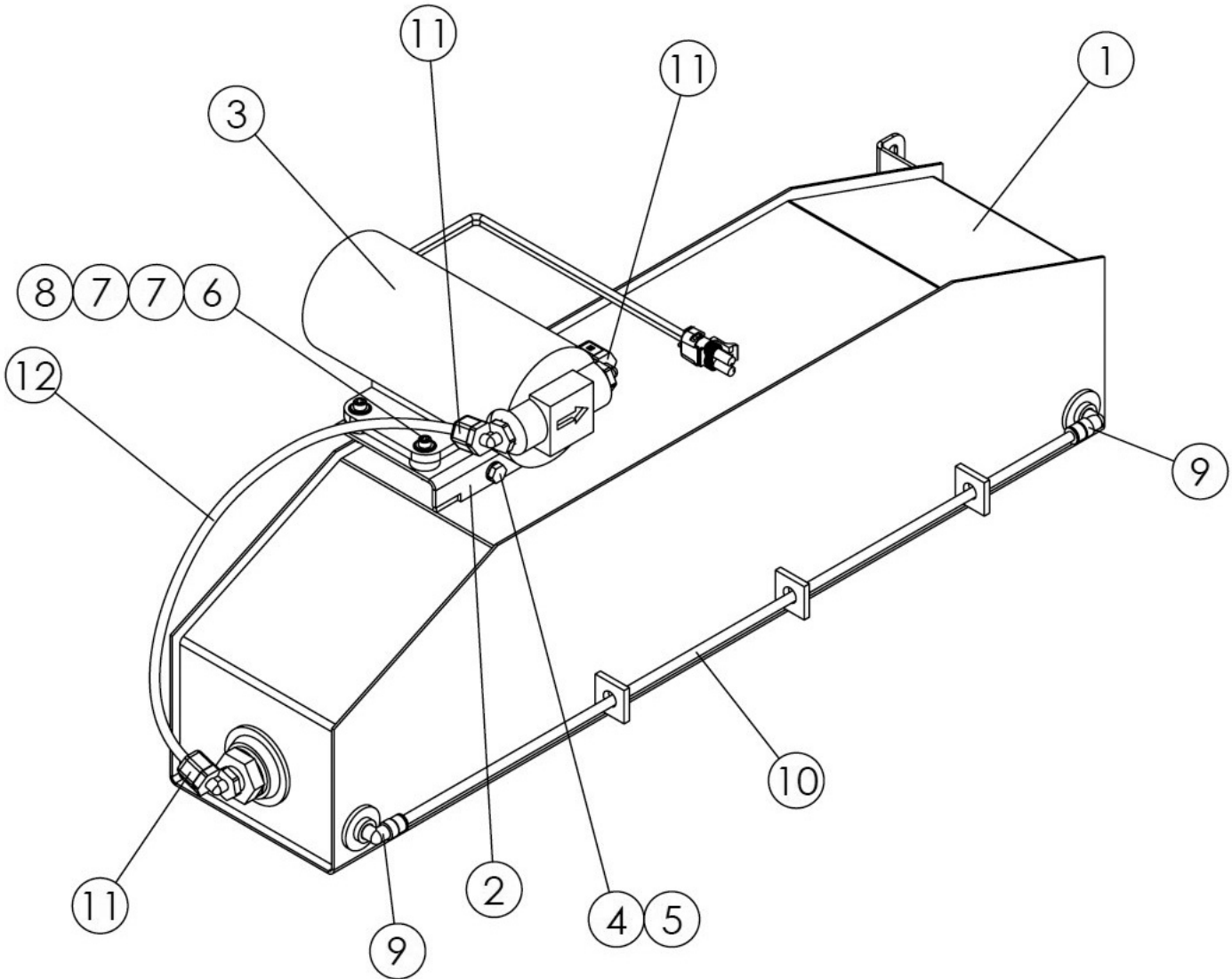

Conveyor Chain Oiler

<u>ITEM</u>	<u>PART NO.</u>	<u>DESCRIPTION</u>	<u>QTY</u>
	310760	Tank - Assy Oiler 30 Btm W/45°	
1	304398	Tank - Wldmt Oiler	1
2	304409	Mount - Pump	1
3	304390	Pump - Assy W/Connector	1
4	36393	Capscrew - .25-20nc X .75 SS	1
5	36418	Washer - Lock .25 SS	1
6	44454	Screw - Sockethead #10-24	4
7	171052	Washer - Flat #10 SS	8
8	56355	Nut - Lock #10-24nc SS	4
9	301337	Fitting - 90 Male 1/8 Npt	2
10	306437	Tube - .25od X .18id Clear	2.031'
11	309902	Elbow - Hdpp .375npt X .25	3
12	301338	Tube - .25od X .062 Blk Nylon	1.25'

Conveyor Chain Oiler

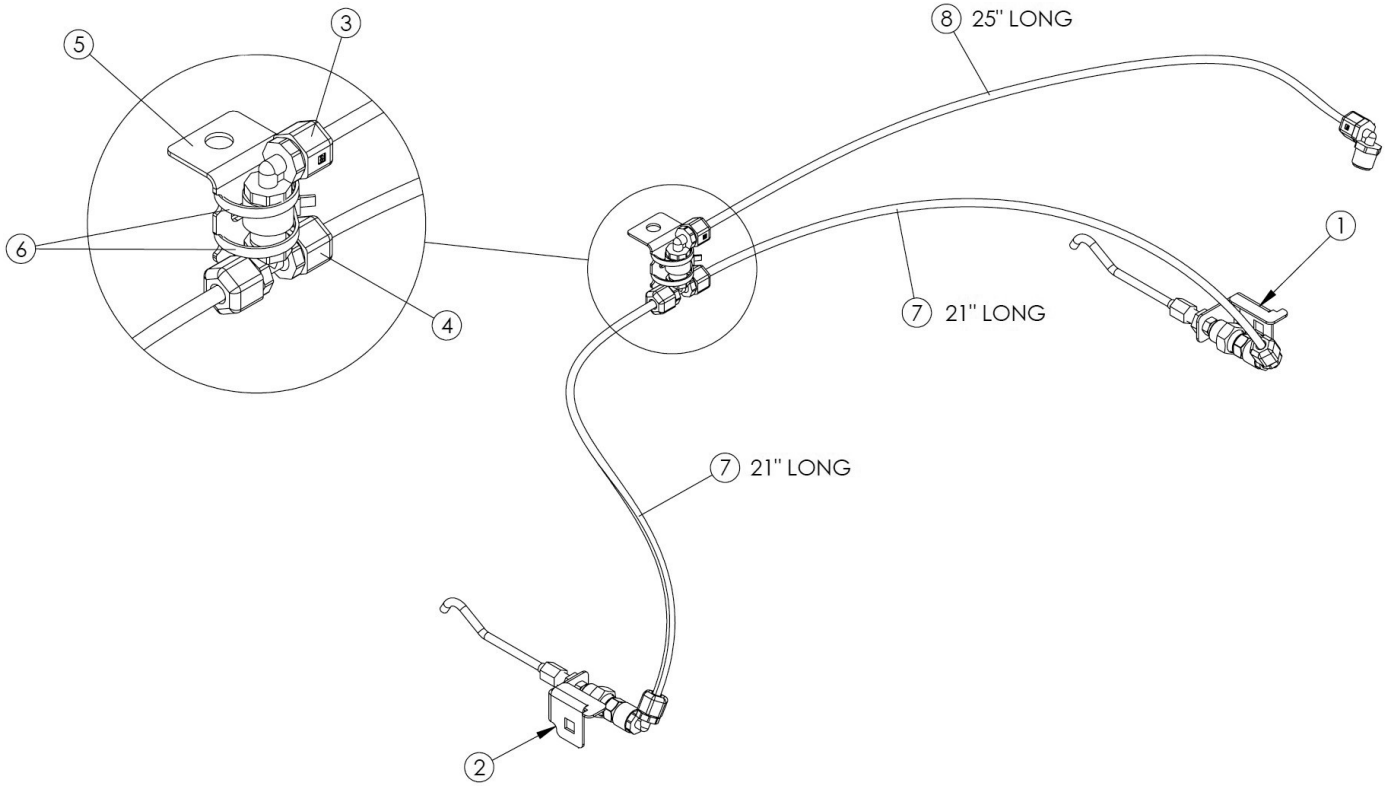

Conveyor Chain Oiler

<u>ITEM</u>	<u>PART NO.</u>	<u>DESCRIPTION</u>	<u>QTY</u>
	314232	NOZZLE - ASSY HOSE	
1	314019	NOZZLE - ASSY LH	1
2	314020	NOZZLE - ASSY RH	1
3	309904	ELBOW - HDPP .25NPTF X .25	1
4	309905	TEE - HDPP .25NPT X .25 TUBING	1
5	306804	BRACKET - COUPLING 304	1
6	99674	STRAP - ZIP TIE 8 BLACK	2
7	317377	LINE - TANK OILER	2
8	314817	LINE - OILER NOZZLE	1
9	306670	TAPE - GAS YELLOW TFE	.05

Wiper Front

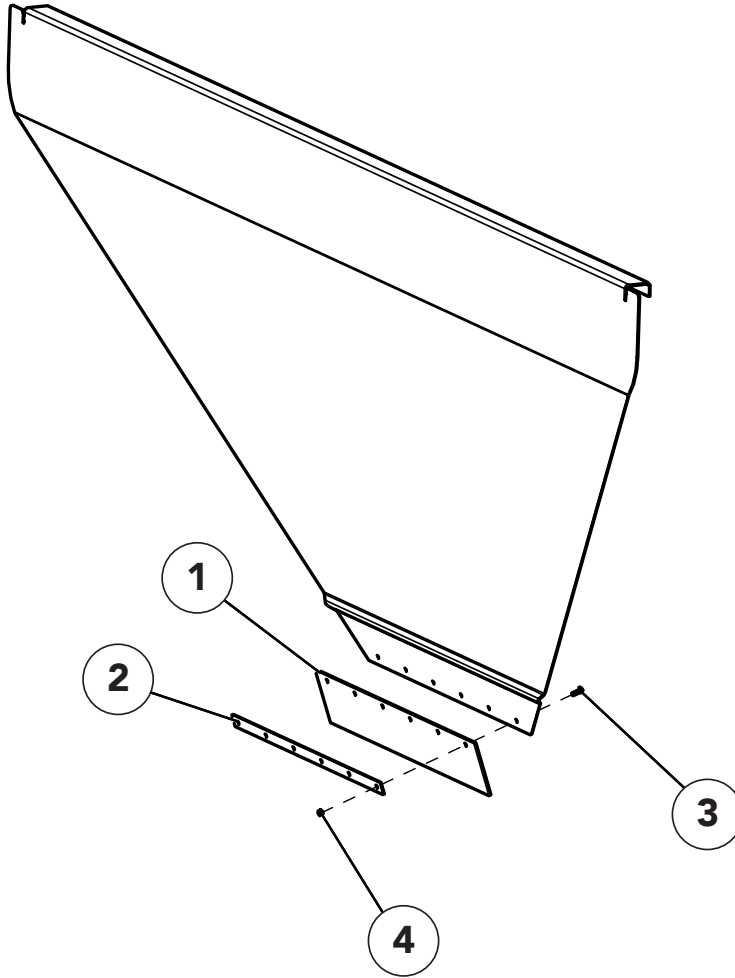

<u>ITEM</u>	<u>PART NO.</u>	<u>DESCRIPTION</u>	<u>QTY</u>
	90826	Belt - Front Wiper Assy, Includes Items 1 - 4	1
1	14743	Wiper – Belt	1
2	71656	Retainer – Belt 304	1
3	32446	Screw – TR HD 1/4 x 3/4	6
4	36412	Nut – Hex 1/4	6

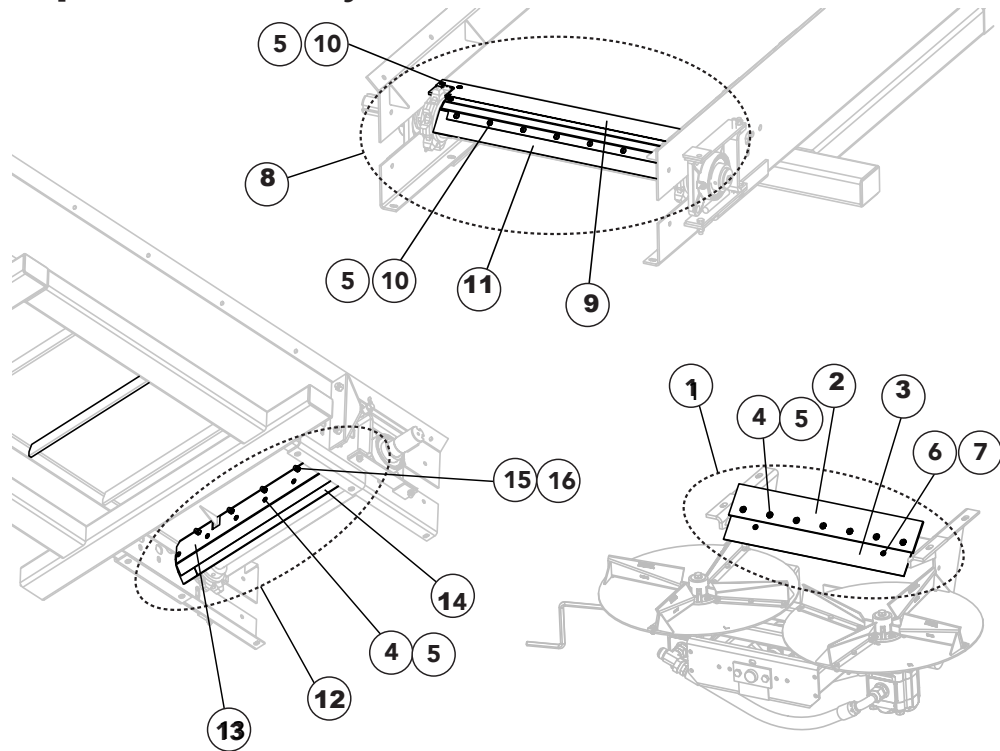
Conveyor**Rear Wiper - #3 Conveyor**

<u>ITEM</u>	<u>PART NO.</u>	<u>DESCRIPTION</u>	<u>QTY</u>
	98086	Lip - Rear 30" Group 304, Includes Items 8 - 16	1
1	96744	Kit - Wiper Belt, Includes Items 2 - 7	1
2	304418	Belt - Rear Wiper 30"	1
3	96746	Plate - Wiper Belt Spinner/Conveyor	1
4	56258	Screw - Truss Head 1/4-20NC x 1/2 SS	7
5	88931	Nut - Tee 1/4	AR
6	32446	Screw - Truss Head 1/4-20NC x 3/4 SS	2
7	42034	Nut - Lock 1/4-20NC SS	2
8	98068	Lip - Rear 30" 304 Assy, Includes Items 9 -11, 5	1
9	98030	Lip - Wldmt Rear 30" 304	1
10	56400	Screw - Flat Head 1/4-20NC x 1/2 SS	13
11	305331	Wiper - 30" Rear Lip	1
12	304416	Wiper - 30" Internal Assy, Includes Items 13, 14, 4, 5	1
13	304422	Mount - 30" Internal Wiper 304	1
14	304423	Rubber - Internal Wiper	1
15	34858	Capscrew - .375-16UNC X 1.5 304	5
16	72054	Nut - Lock 3/8-16NC SS	5
17	36425	Washer- Flat .375 SS	5

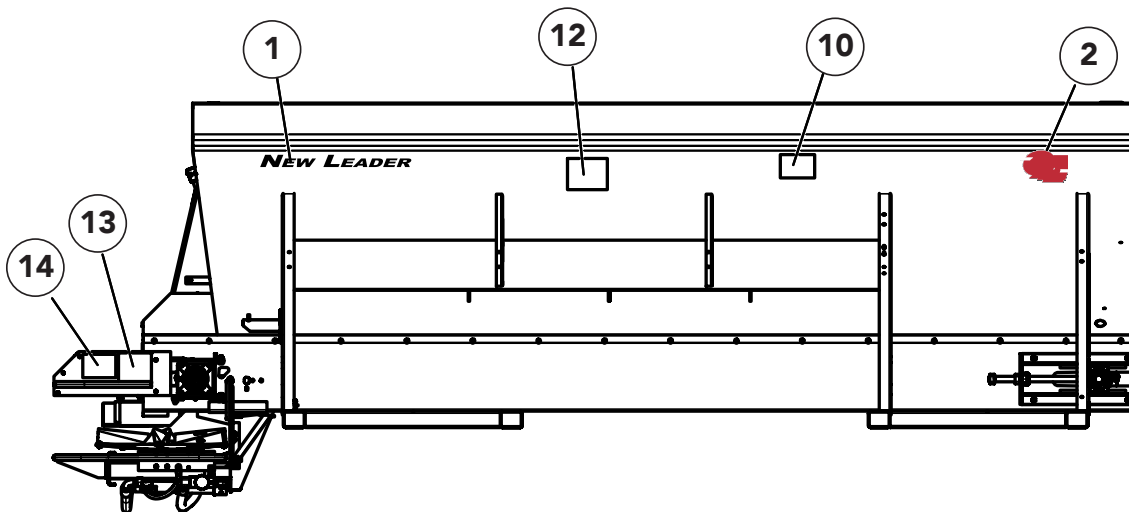
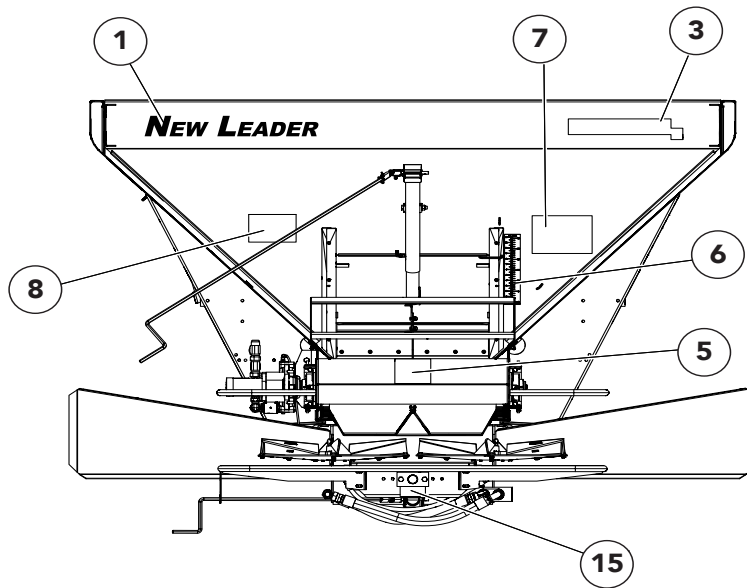
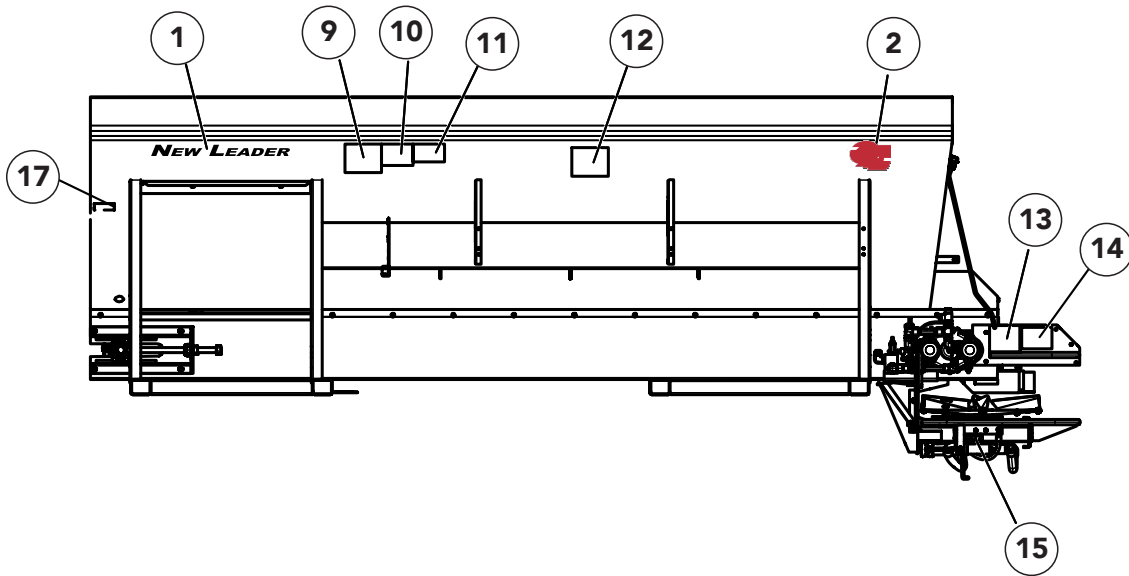

<u>ITEM</u>	<u>PART NO.</u>	<u>DESCRIPTION</u>	<u>QTY</u>
1	312561	Decal - New Leader Black Decal - New Leader White	3
2	87122 87129	Decal - G4 Red/Black Decal - G4 Black/White	2 2
3	306151	Decal - L4000G4 Black	1
4	Not Used		
5	87109	Decal - New Leader G4	1
6	23769	Decal - Feedgate Slide Scale	1
7	368	Decal - Danger, Flying Material	1
8	71526	Decal - Notice, Spread Pattern	1
9	150034	Decal - Caution, Improper Operation	1
10	364	Decal - Danger, Moving Part	2
11	321	Decal - Caution, Hazardous Material	1
12	39138	Decal - Warning, High Pressure Fluid	2
13	55630	Decal - Warning, Falling Hazard	2
14	55631	Decal - Warning, Moving Part Hazard	2
15	98319	Decal - Patent 6,517,281	1
16	*39200	Decal - Warning, Fenders	2
17	315865	Decal - Warning, Prop 65	1

* - Not Shown

Spinner

Spinner - Material Divider

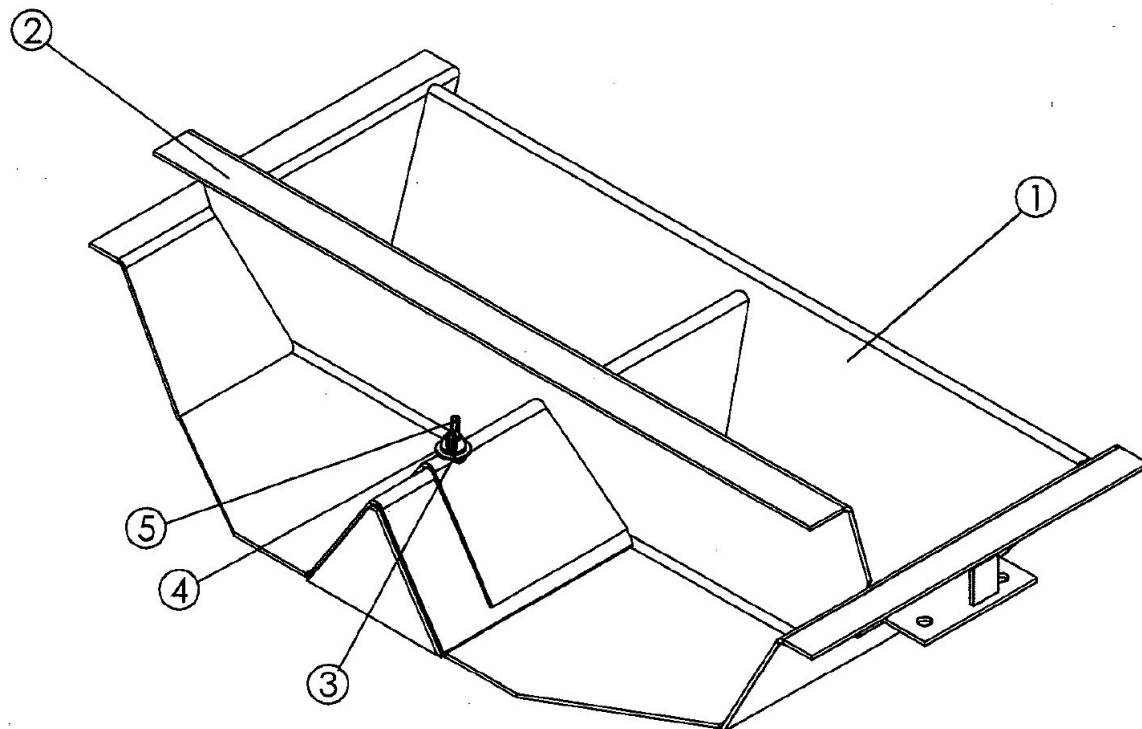

ITEM	PART NO.	DESCRIPTION	QTY
	87108	Divider – Material Assy, Includes 1-5	
1	87054	Divider – Wldmt	1
2	87064	Deflector – Rear Wldmt	1
3	20673	Nut – Wing 3/8 SS	1
4	36425	Washer – Flat 3/8 SS	1
5	36420	Washer – Lock 3/8 SS	1

Hillside Divider

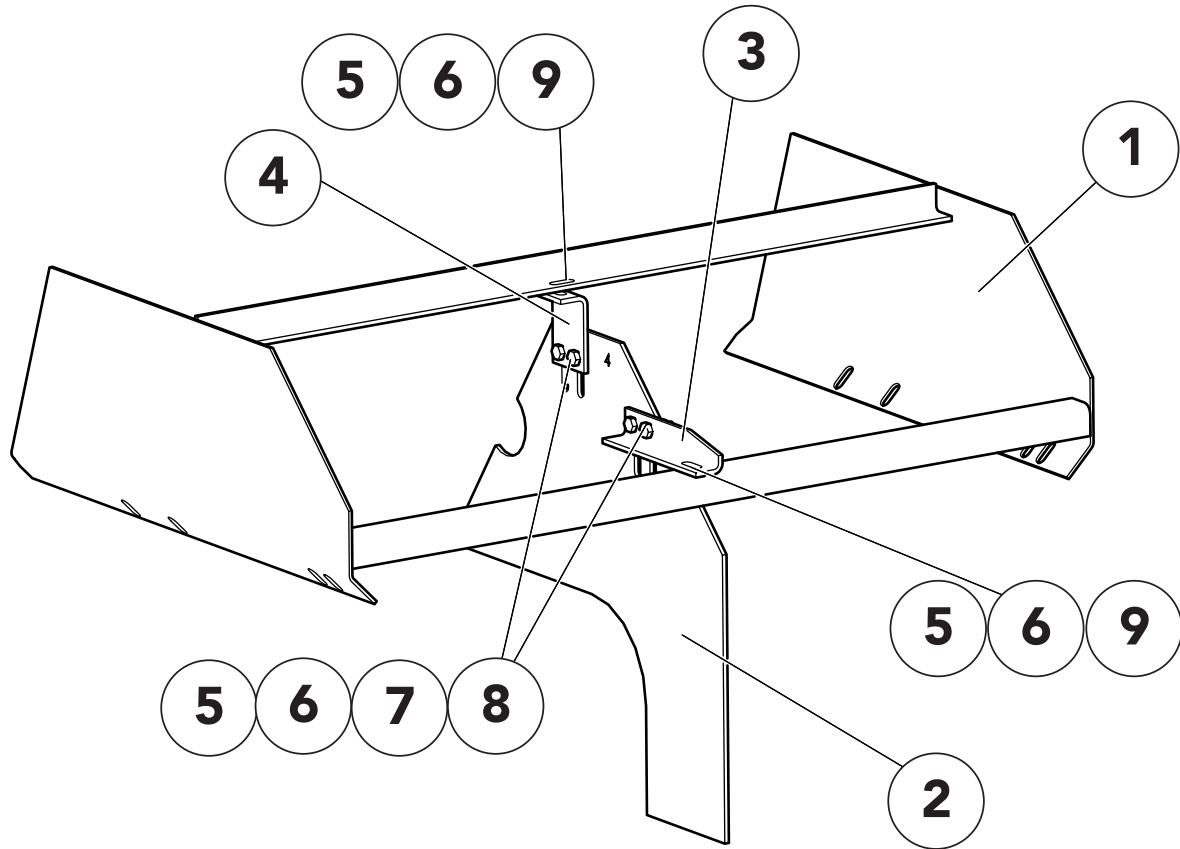

ITEM	PART NO.	DESCRIPTION	QTY
1	86788	Bracket – Wldmt Support	1
2	82288	Panel – Hillside Divider	1
3	56879	Bracket – Clamp	1
4	56880	Angle – Clamp	1
5	34580	Cap Screw – 5/16 x 1	6
6	36424	Washer – Flat 5/16	8
7	36419	Washer – Lock 5/16	4
8	36413	Nut – Hex 5/16	4
9	42221	Nut – Lock 5/16	2

Note: Use chain shield hardware to attach Item 1 to sills.

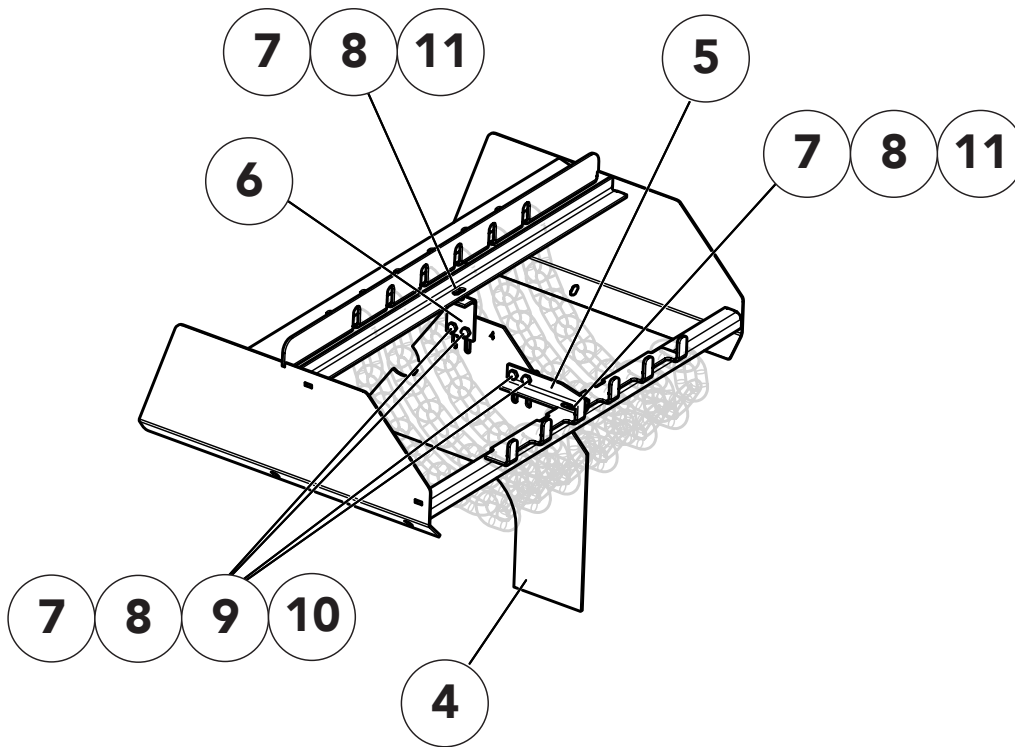
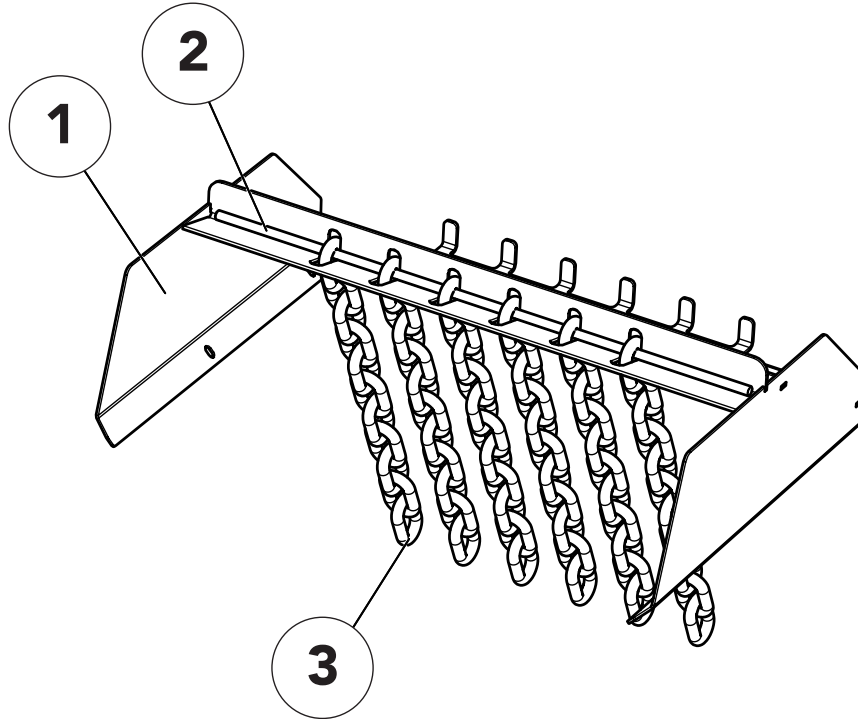

OPTIONAL HILLSIDE DIVIDER PANEL

Anti-Slab

<u>ITEM</u>	<u>PART NO.</u>	<u>DESCRIPTION</u>	<u>QTY</u>
	312953	Anti-Slab Assy, Includes Items 1 - 3	1
1	312954	Support - Wldmt 304	1
2	312959	Round - 1/2 x 31 304	1
3	312960	Chain	6
4	82288	Panel - Hillside Divider	1
5	56879	Bracket - Clamp	1
6	56880	Angle - Clamp	1
7	34580	Cap Screw - 5/16-18NC x 1 SS	6
8	36424	Washer - Flat 5/16 SS	8
9	36419	Washer - Lock 5/16 SS	4
10	36413	Nut - Hex 5/16-18NC SS	4
11	42221	Nut - Lock 5/16-18NC SS	2

Spinner Assembly

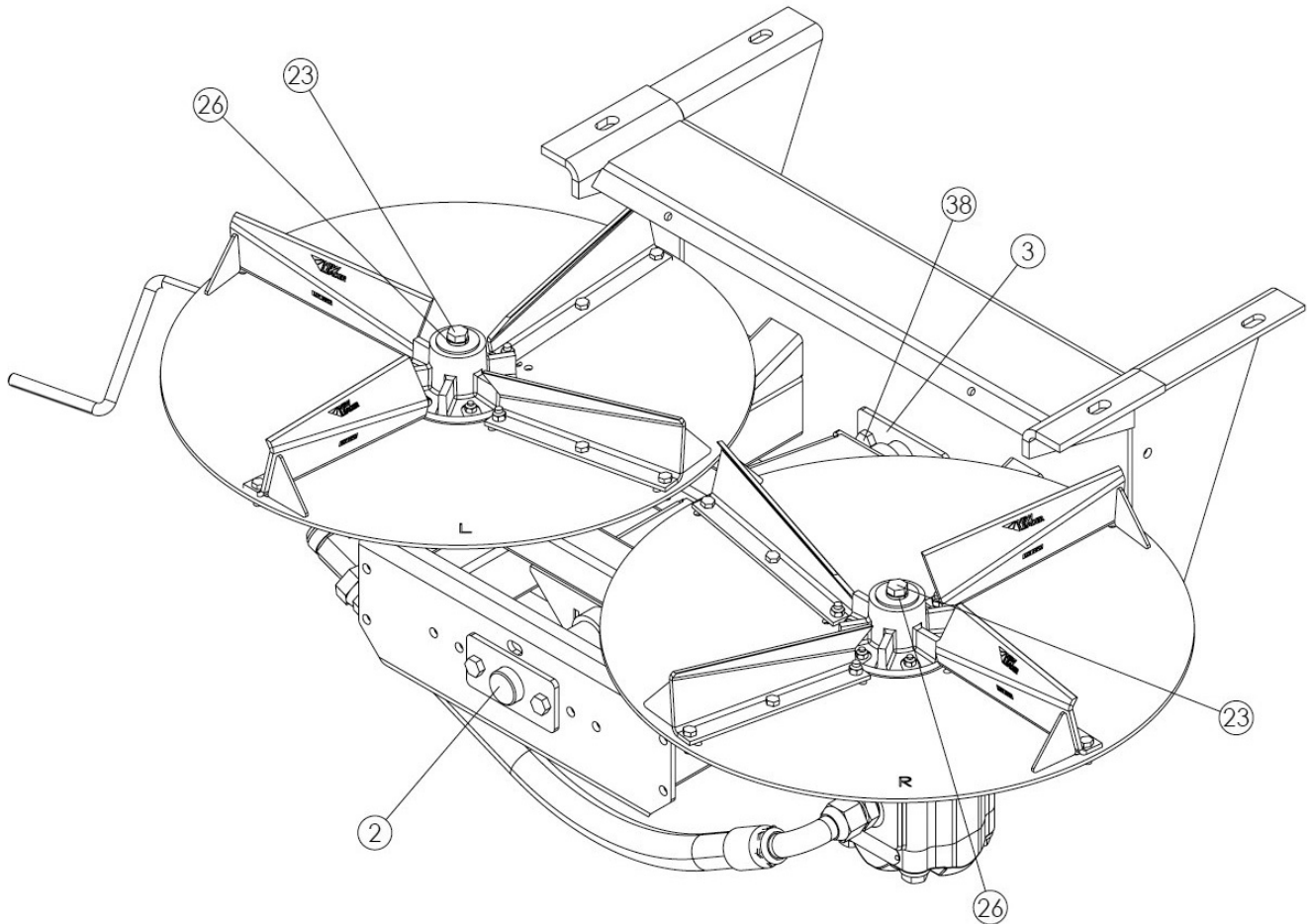
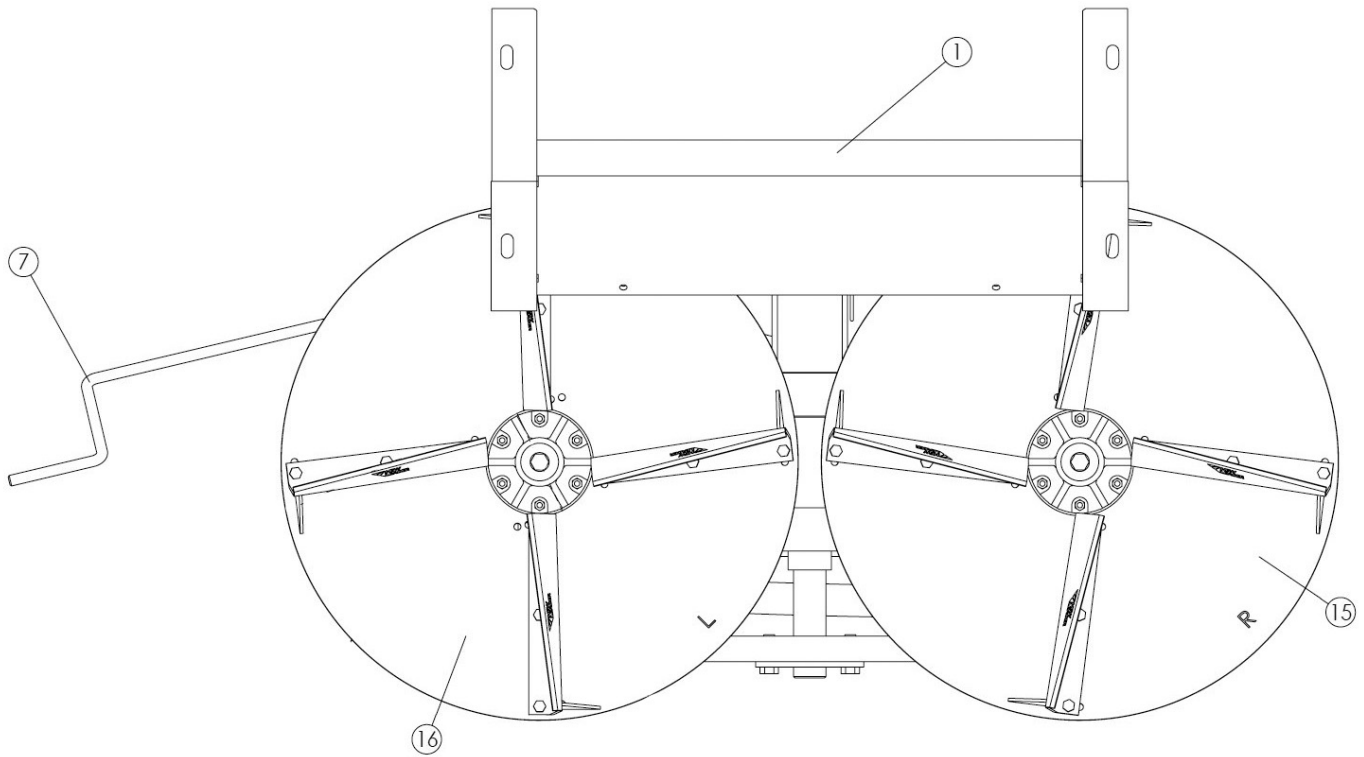

Spinner Assembly

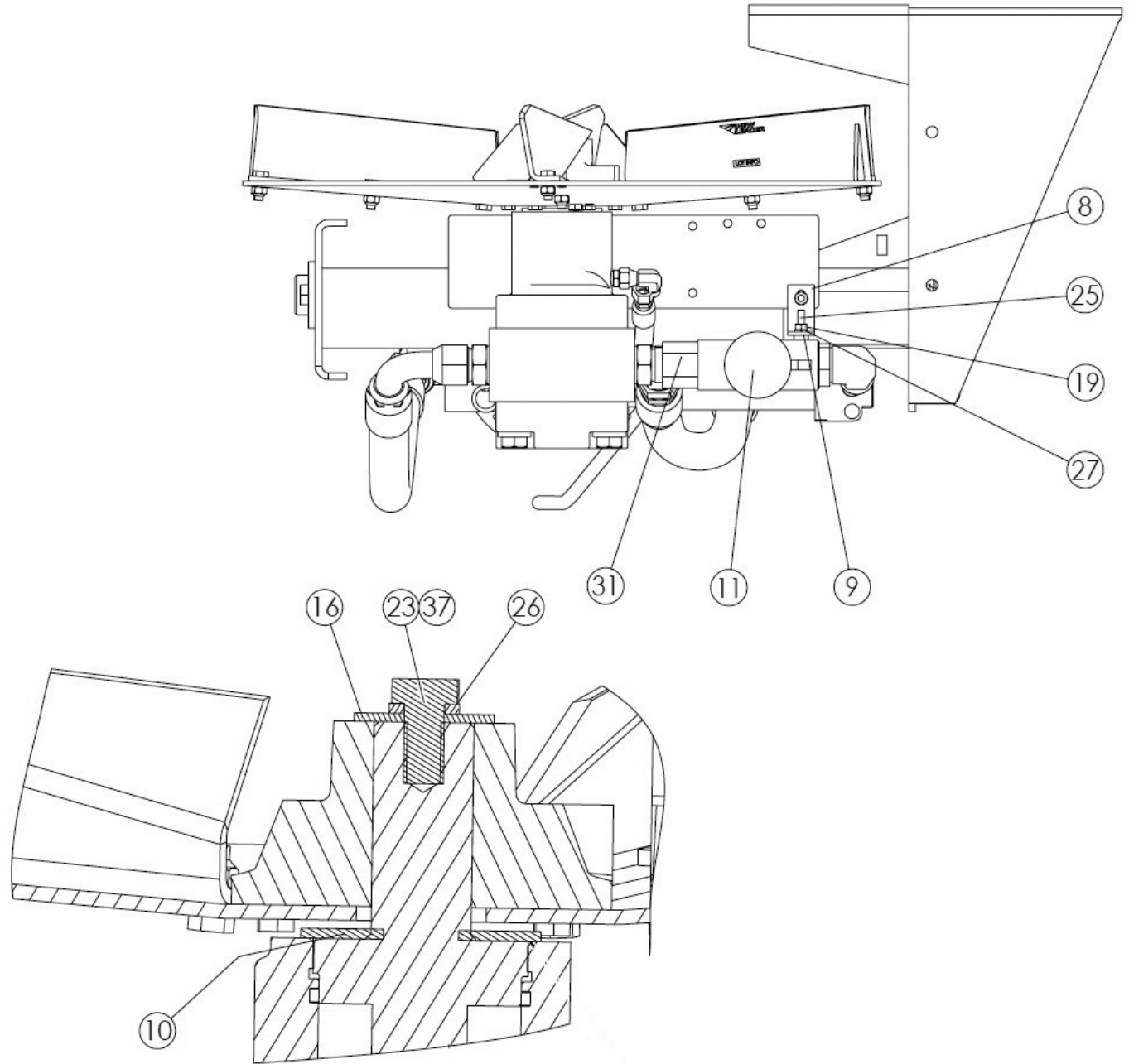

Spinner Assembly

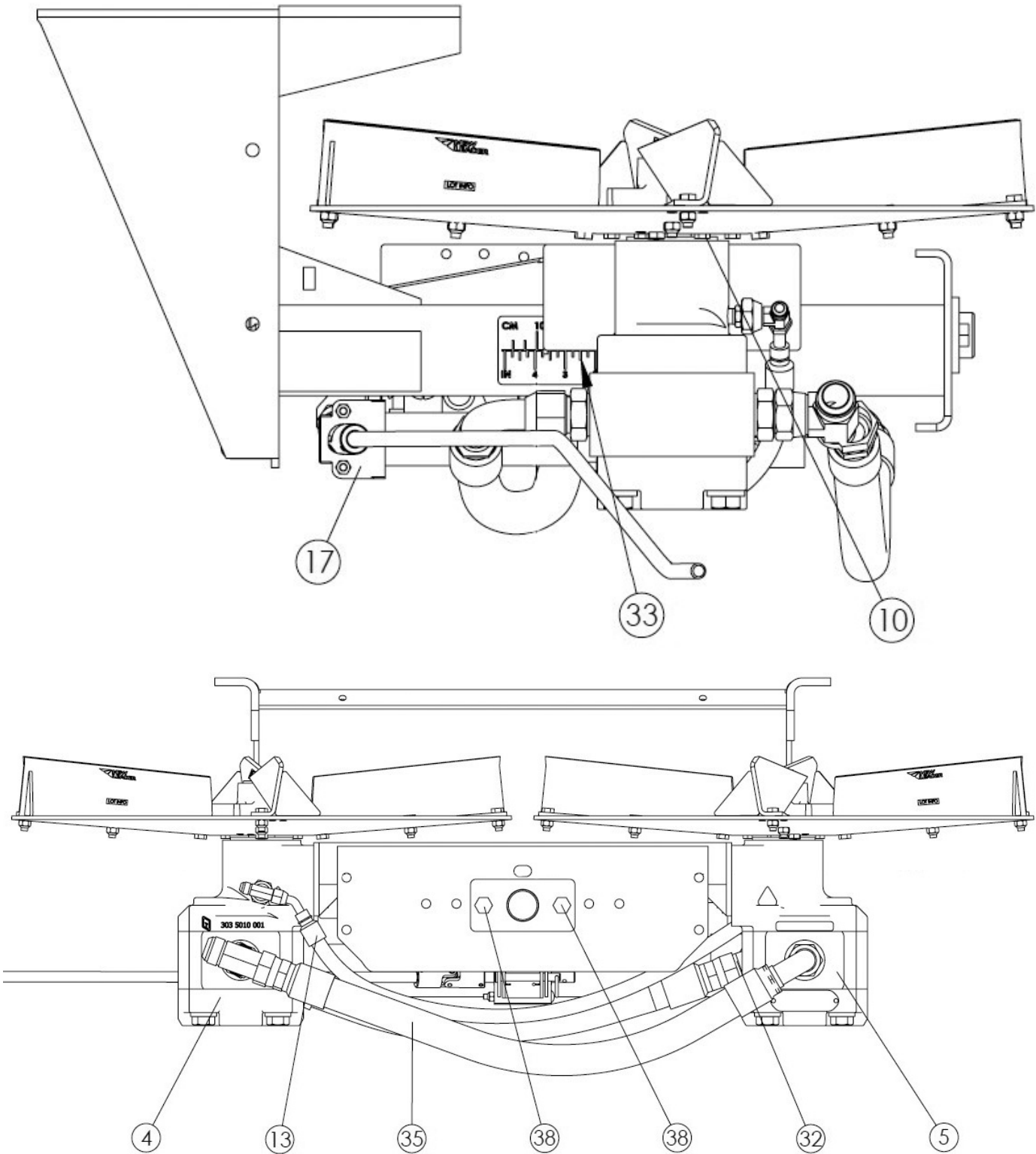

Spinner Assembly

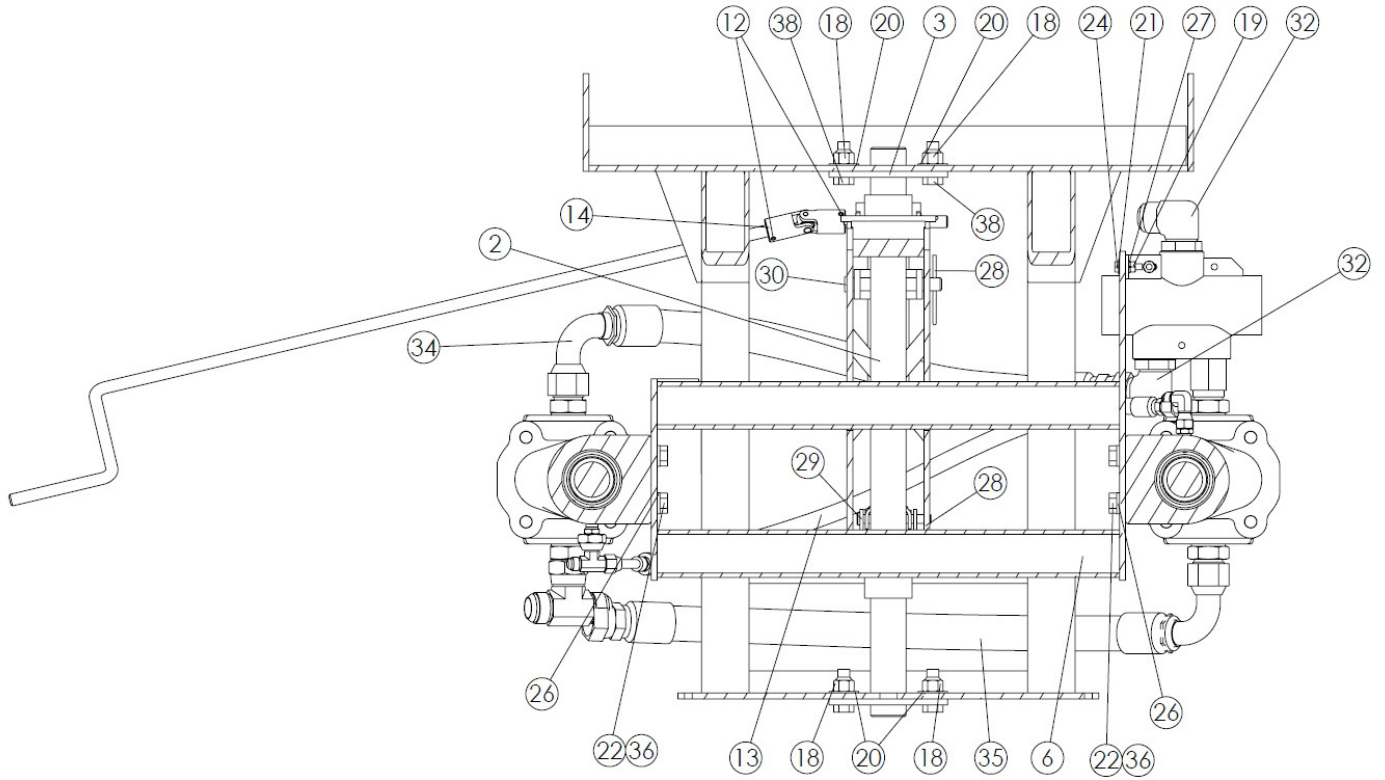

Spinner Assembly

ITEM	PART NO.	DESCRIPTION	QTY
1	87090	Plate - Wldmt Back 304	1
2	87021	Shaft - Wldmt 304	1
3	87023	Plate - Mounting Shaft 304	1
4	305948	Motor - Assy Style li Lh	1
5	305949	Motor - Assy Style li Rh	1
6	314734	Mount - Wldmt Motor 304	1
7	311719	Handle - 304	1
8	87025	Angle - Mounting Valve 5 X 48	1
9	76825	Hinge - Pipe .25 X 1 304	1
10	305571	Washer - Rubber 3od X .94id X .13 Thick 60DURO	2
11	71781	Valve - 50/50 Flow Divider	1
12	312268	Pin - Roll .188 X 1.0 SS	2
13	87112	Hose - Assy .375 X 28.1 100r1	1
14	85002	Joint - U	1
15	87105	Disc - Assy 24 Rh	1
16	87106	Disc - Assy Lh	1
17	312975	Jack - Assy 4.5 304	1
18	39016	Nut - Lock .5-13nc SS	4
19	36412	Nut - Hex .25-20nc SS	2
20	36426	Washer - Flat .5 SS	4
21	36423	Washer - Flat .25 SS	1
22	36402	Capscrew - .5-13nc X 1.25 SS	8
23	36401	Capscrew - .5-13nc X 1 SS	2
24	36395	Capscrew - .25-20nc X 1 SS	1
25	34865	Capscrew - .25-20nc X 2.25 SS	1
26	36422	Washer - Lock .5 SS	10
27	36418	Washer - Lock .25 SS	2
28	36429	Pin - Hair .148 X 2.688 SS	2
29	6547	Pin - Clevis .375 X 3 SS	1
30	311425	Pin - Jack 304	1
31	34810	Fitting - 16-16 Non Standard	1

Spinner Assembly

<u>ITEM</u>	<u>PART NO.</u>	<u>DESCRIPTION</u>	<u>QTY</u>
32	29840	Fitting - 16-16 070220	2
33	87110	Decal - Scale	1
34	98101	Hose - Assy 1od X 26.5 100r12	1
35	87111	Hose - Assy 1 X 26.5 100r2	1
36	301315	Loctite - 243	-
37	311082	Compound - Antiseize Heavy	-
38	36539	Capscrew - .5-13nc X 1.5 SS	4

Disc Assembly

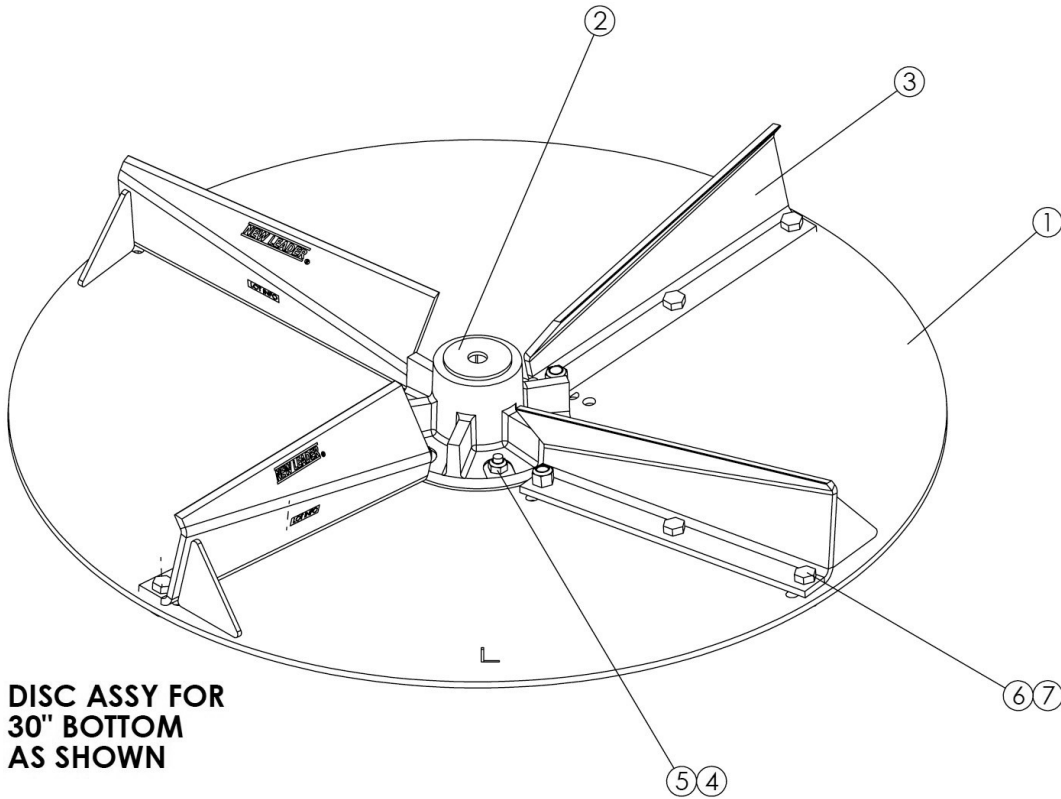

DISC ASSY FOR
30" BOTTOM
AS SHOWN

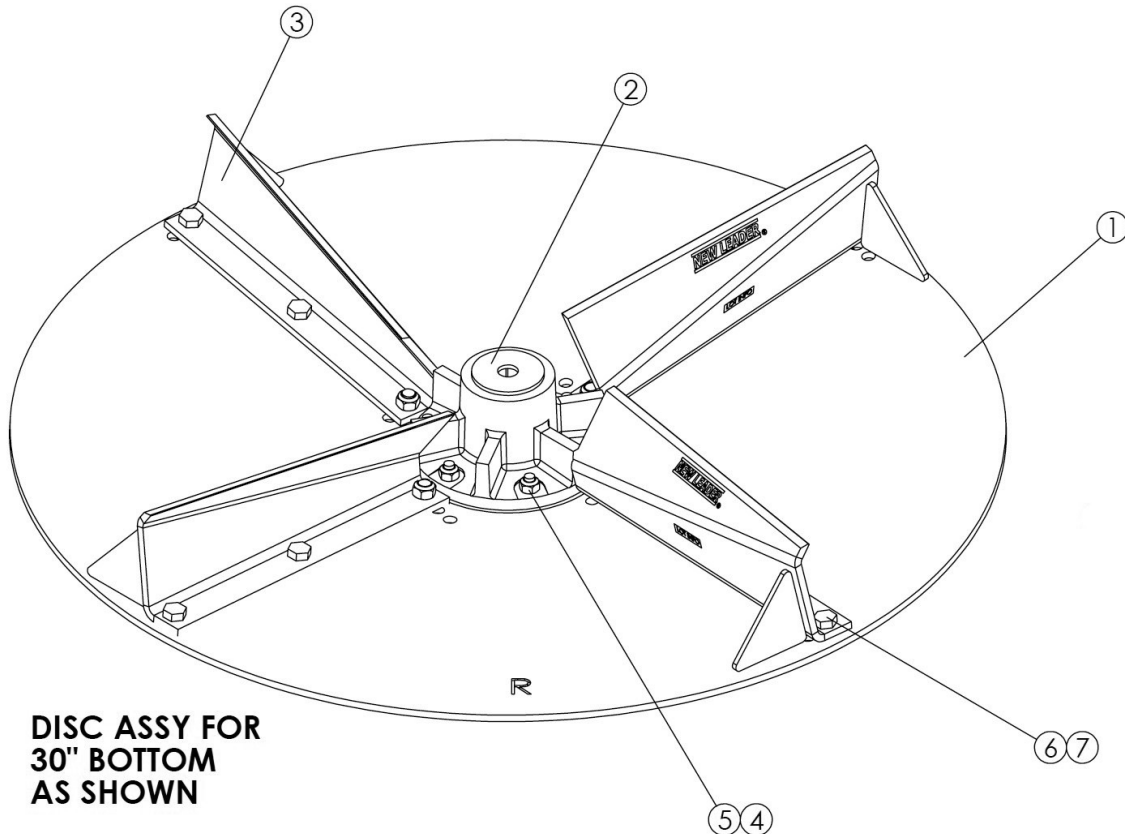

DISC ASSY FOR
30" BOTTOM
AS SHOWN

Disc Assembly Cont.

<u>ITEM</u>	<u>PART NO.</u>	<u>DESCRIPTION</u>	<u>QTY</u>
1	27056-X5	DISC - DISTRIBUTOR LH PAINTED	1
-	27056-X4	DISC - DISTRIBUTOR RH PAINTED	1
-	57830-X3	DISC - DIST 24 4-FIN .25 LH	1
-	57830-X2	DISC - DIST 24 4-FIN .25 RH	1
2	10877	HUB - WLDMT	1
3	309092	FIN - WLDMT LH	4
-	309091	FIN - WLDMT RH	4
4	20005	CAPSCREW - .25-20NC X 1 GR5 ZN	12
5	20676	NUT - LOCK .25-20NC ZN	12
6	20035	CAPSCREW - .313-18NC X .875 GR5	24
7	20677	NUT - LOCK .313-18NC ZN	24

Spinner Guards & Deflectors

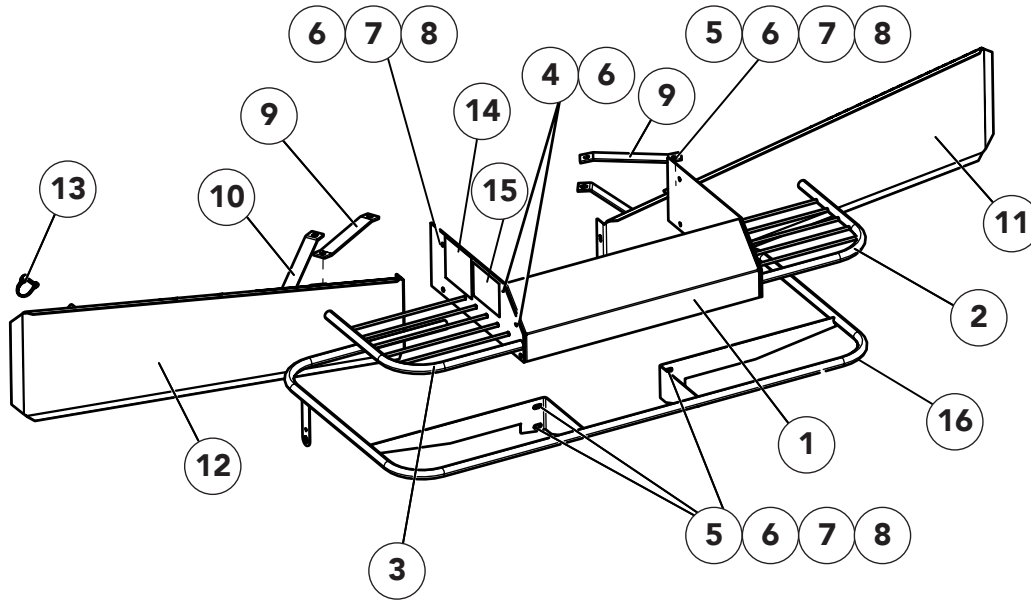

ITEM	PART NO.	DESCRIPTION	QTY
1	87066-X1 305712	Guard – Center Section	1
		Guard – Center Section, SMV Mount	1
2	87027-X1	Guard – RH Wldmt	1
3	87031-X1	Guard – LH Wldmt	2
4	72054	Nut – Nylon Lock 3/8-16NC SS	6
5	36425	Washer – Flat 3/8 SS	12
6	36398	Cap Screw - 3/8-16NC x 1 SS	18
7	36420	Washer – Lock 3/8 SS	12
8	36414	Nut – Hex 3/8-16NC SS	12
9	87068	Bar – Stiffener	2
10	305040	Bar – Stiffener Lower 304	2
11	305043 305075	Deflector – RH Wldmt 108" OAW	1
		Deflector – RH Wldmt 126" OAW	1
12	305044 305076	Deflector – LH Wldmt 108" OAW	1
		Deflector – LH Wldmt 126" OAW	1
13	85359	Pin - Snap	1
14	55630	Decal - Warning, Falling Hazard	1
15	55631	Decal - Warning, Moving Part Hazard	1
16	87032-X1	Guard - Wldmt Sprnr Lower 304	1

Spinner

Spinner Speed Sensors

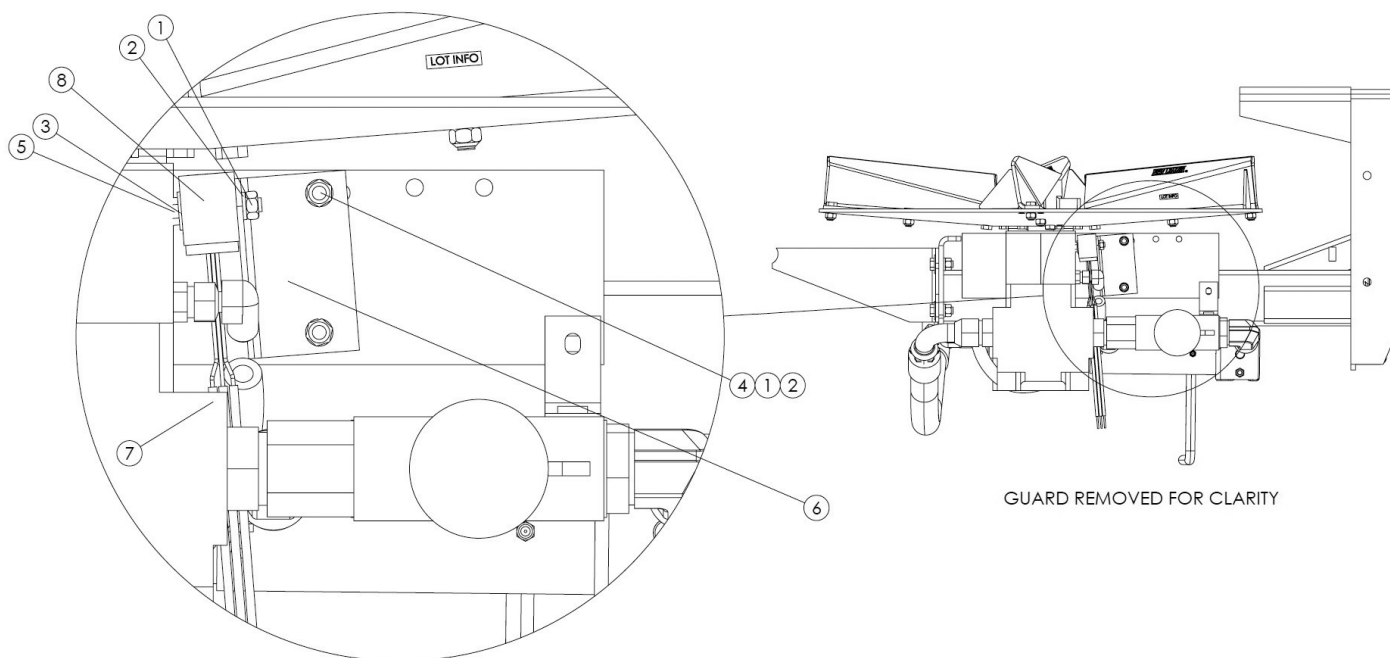

ITEM	PART NO.	DESCRIPTION	QTY
1	36412	Nut - Hex .25-20nc SS	4
2	36418	Washer - Lock .25 SS	4
3	36423	Washer - Flat .25 SS	2
4	36393	Capscrew - .25-20nc X .75 SS	2
5	42448	Capscrew - .25-20nc X 1.5 SS	2
6	86672	Bracket - 304	1
7	89009	Cable - Sensor Ext 27'	1
8	89011	Sensor - Assy W/Block	1

Spinner Guards & Deflectors-Fertilizer

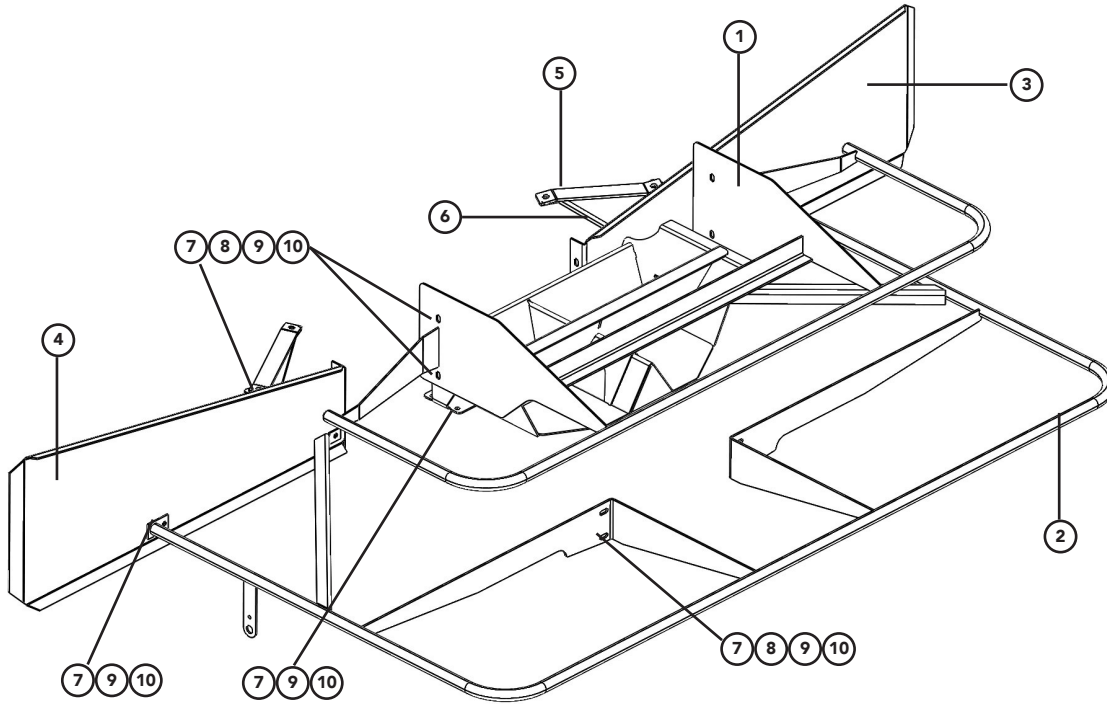

<u>ITEM</u>	<u>PART NO.</u>	<u>DESCRIPTION</u>	<u>QTY</u>
1	317239	Divider – Wldmt w/Guard 34"	1
2	304913	Guard – Wldmt 30" Spinner 304	1
3	305320	Shield – Wldmt RH 304	1
4	305321	Shield – Wldmt LH 304	1
5	87068	Bracket – Shield 304	2
6	305040	Bar – Stiffener Lower 304	2
7	36398	Cap Screw – 3/8 x 1 SS	22
8	36425	Washer – Flat 3/8 SS	20
9	36420	Washer – Lock 3/8 SS	22
10	36414	Nut – Hex 3/8 SS	20

Body

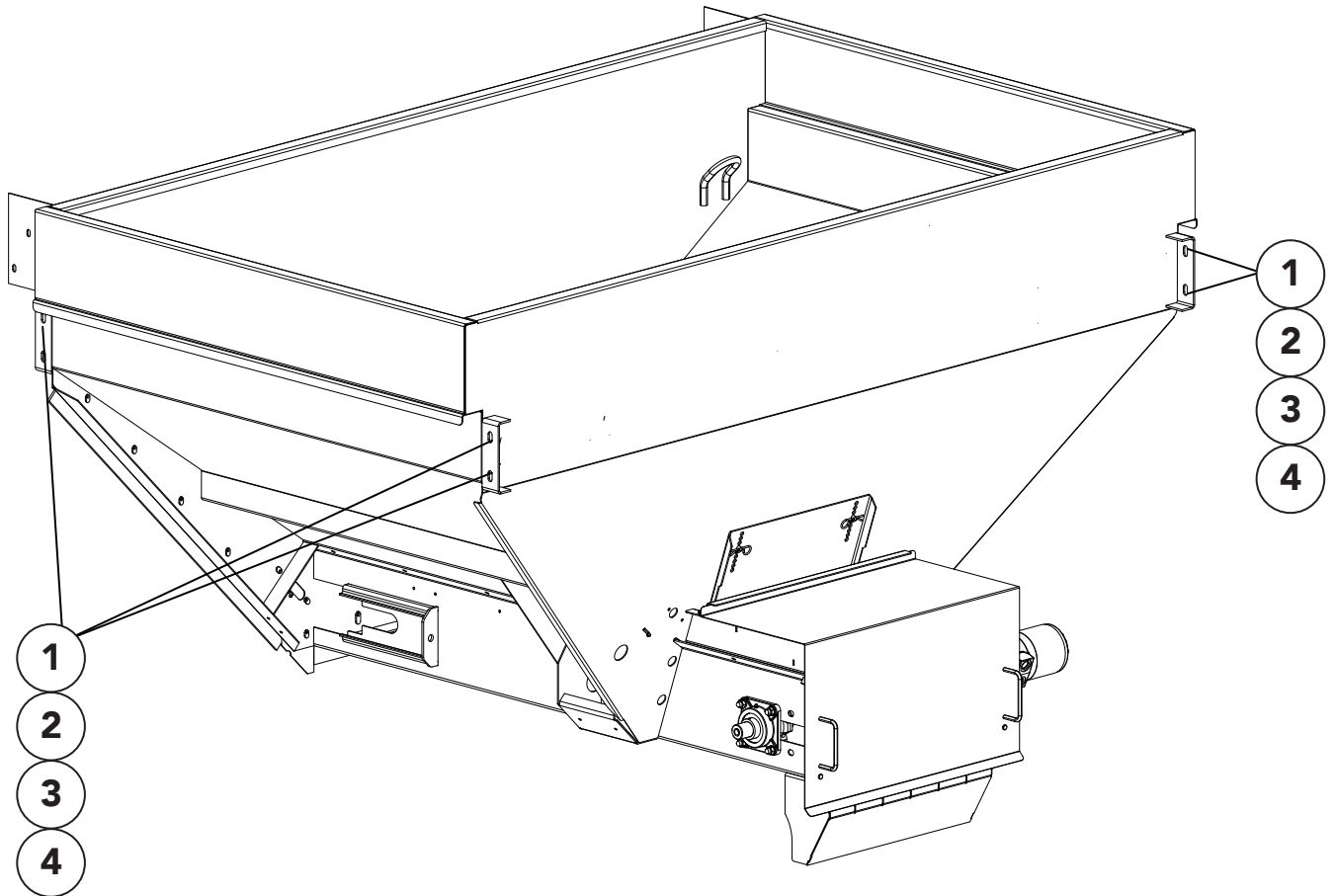

ITEM	PART NO.	DESCRIPTION	QTY
	86951	Hardware - Kit Mount, Includes Items 1 - 4	
1	20128-X1	Cap Screw - 1/2 x 1 1/4 Grade 8	8
2	20695	Washer - Flat 1/2	16
3	20714	Washer - Lock 1/2	8
4	20646	Nut - Hex 1/2	8

MultApplier

Rear Feedgate - Style I

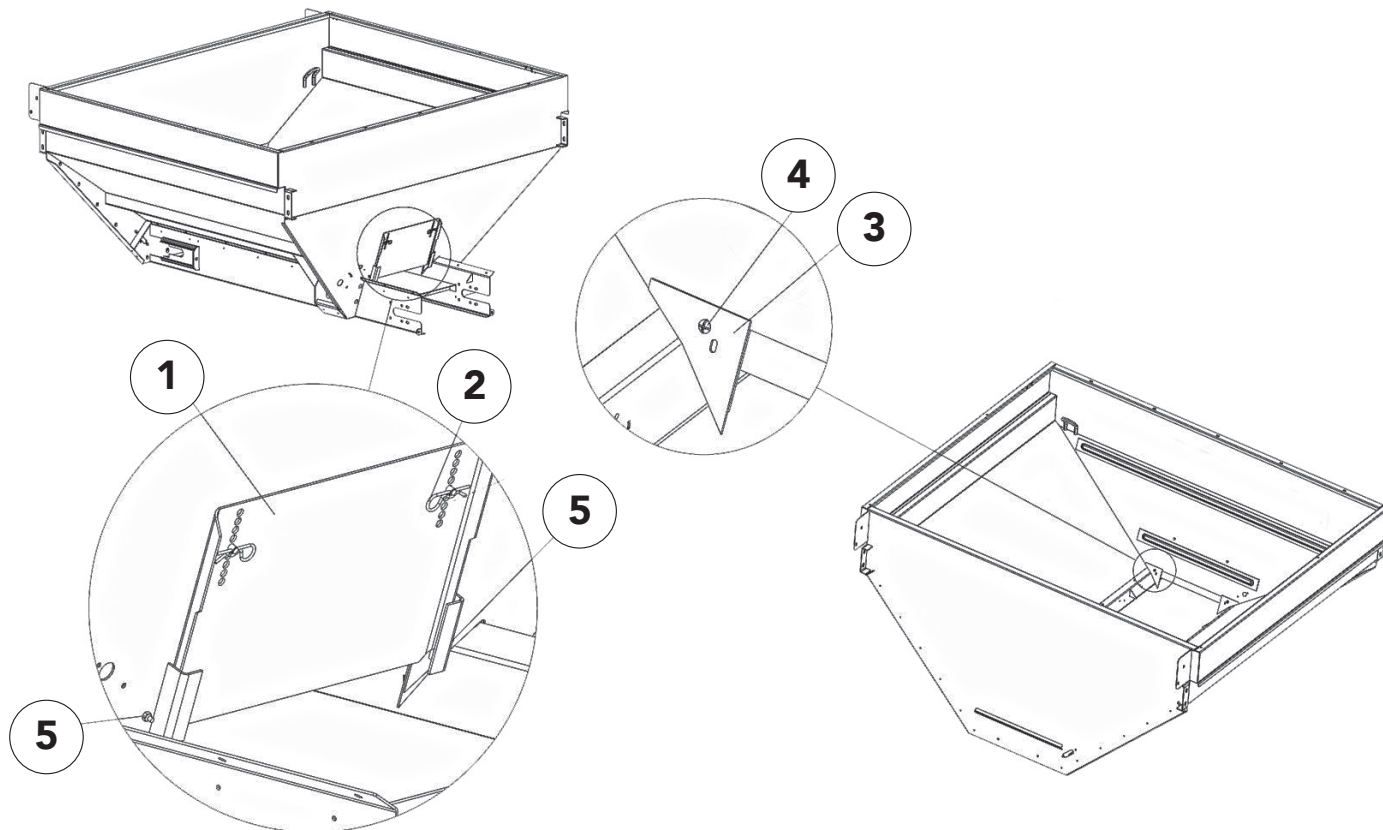

ITEM	PART NO.	DESCRIPTION	QTY
1	306579	Feedgate - 304	1
2	36429	Pin - Hair .148 x 2.688 SS	2
3	306558	Sealer - Feedgate Bolt-In 304	2
4	32446	Screw - Truss Head .25-20NC X	2
5	42034	Nut - Lock .25-20NC SS	2

Rear Feedgate - Style II

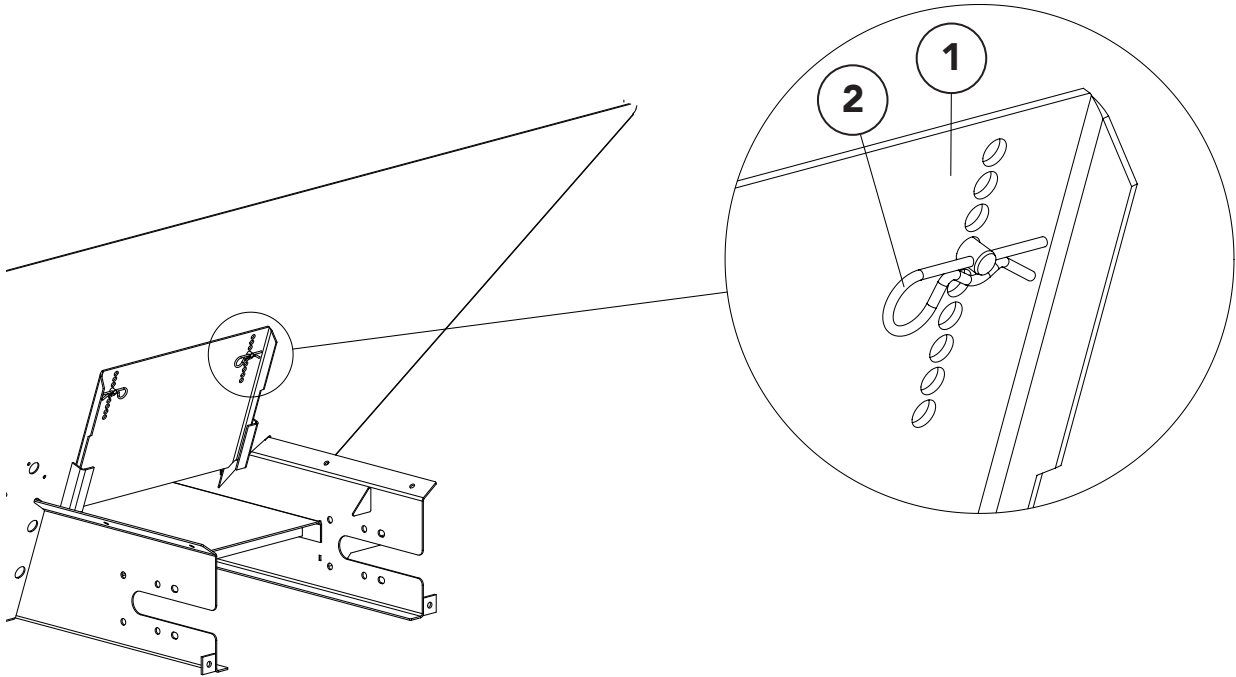

ITEM	PART NO.	DESCRIPTION	QTY
1	306579	Panel - Feedgate	1
2	36429	Pin - Hair	2
3	*306558	Sealer - Feedgate Bolt-In 304	2
4	*32446	Screw - Truss Head .25-20NC X .75 SS	2
5	*42034	Nut - Lock .25-20NC SS	2

* NOT SHOWN

MultApplier

Front Feedgate & Wiper - Style I

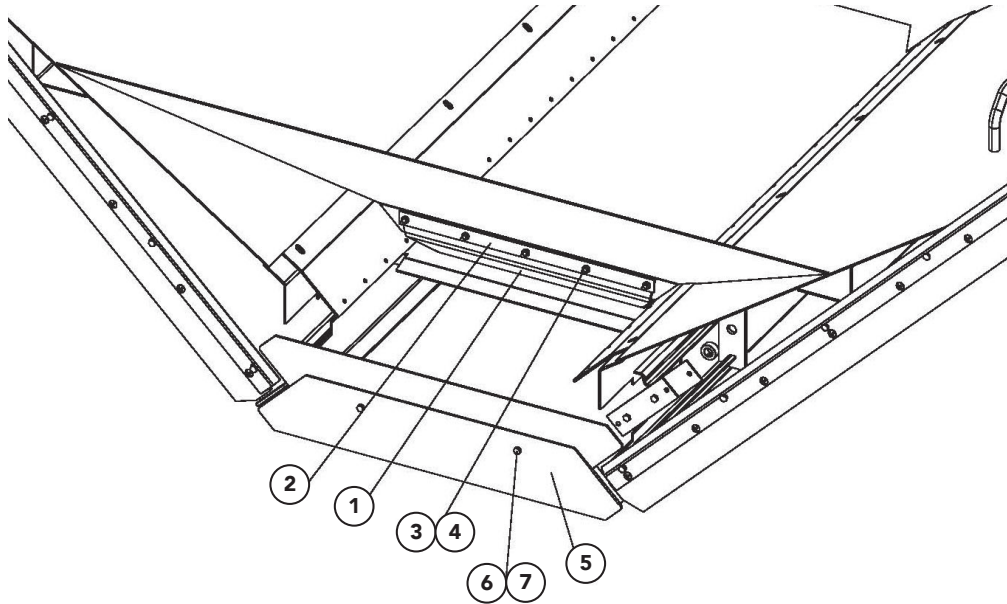

Note: Front endgate removed for clarity.

<u>ITEM</u>	<u>PART NO.</u>	<u>DESCRIPTION</u>	<u>QTY</u>
1	39426	Wiper – Belt Front	1
2	54230	Retainer – Wiper	1
3	42033	Screw - Truss Head 1/4 x 1	5
4	36412	Nut – Hex 1/4	5
5	86868	Feedgate - Panel 1.5"	1
	96984	Feedgate - Panel 2"	1
6	36398	Cap Screw - 3/8 x 1	2
7	36420	Washer - Lock 3/8	2

Front Feedgate & Wiper- Style II

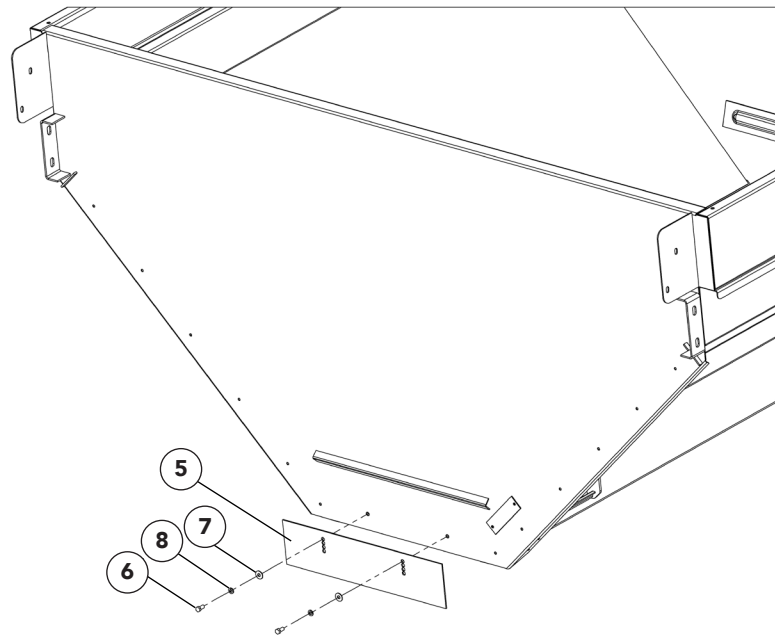
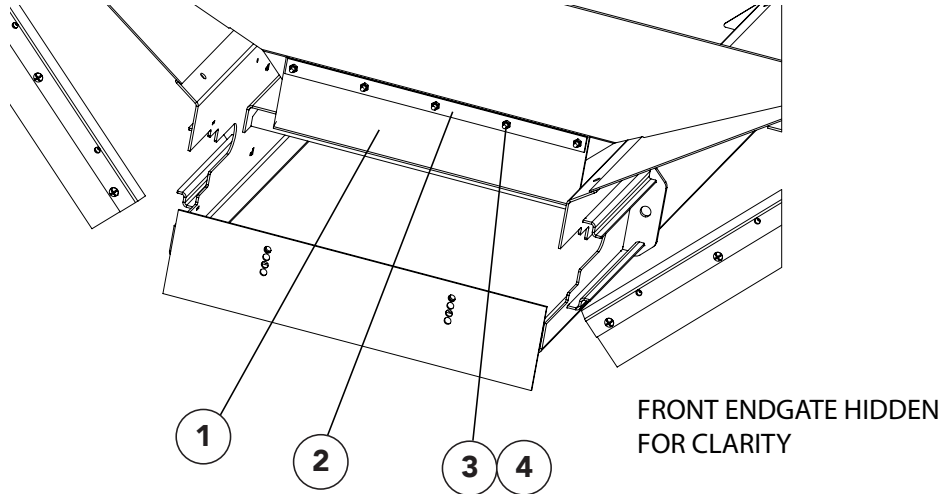

<u>ITEM</u>	<u>PART NO.</u>	<u>DESCRIPTION</u>	<u>QTY</u>
1	39426	Wiper – Belt Front	1
2	54230	Retainer – Wiper	1
3	42033	Screw – Machine 1/4-20NC x 1	5
4	36412	Nut – Hex 1/4-20NC	5
5	306583	Feedgate - 304	1
6	36293	Cap Screw - 3/8-16NC x 3/4 SS	2
7	36425	Washer - Flat 3/8 SS	2
8	36420	Washer - Lock 3/8 SS	2

Sealer - Style I

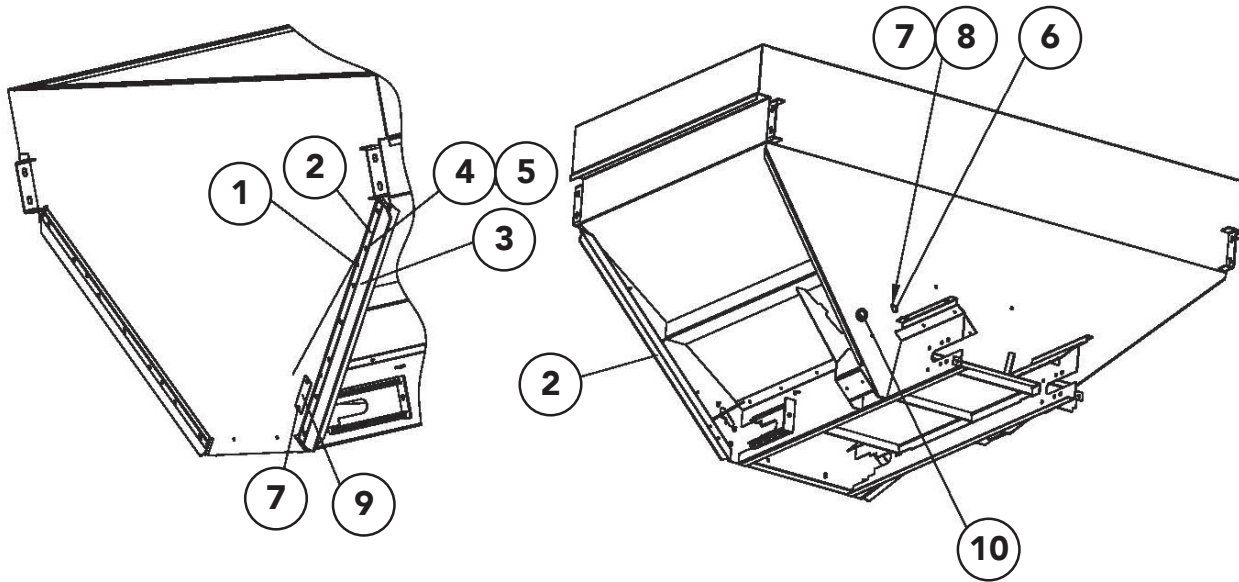

ITEM	PART NO.	DESCRIPTION	QTY
	97967	Seal - Assy, Includes 2-5	
1	36395	Cap Screw - 1/4-20NC x 1 SS	10
2	97966	Retainer - Seal 304	1
3	97968	Seal - 3 x 1/4 x 47-7/8	1
4	88931	Nut - Tee 1/4 x 1/4	14
5	56258	Screw - Truss Head 1/4-20 x 1/2 SS	14
6	305832	Plate - Bin Sensor	1
7	36393	Cap Screw - 1/4-20NC x 3/4 SS	4
8	42034	Nut - Lock 1/4-20 SS	2
9	307125	Plate - Bin Sensor 304	1
10	34129	Grommet - Rubber	1

Sealer - Style II

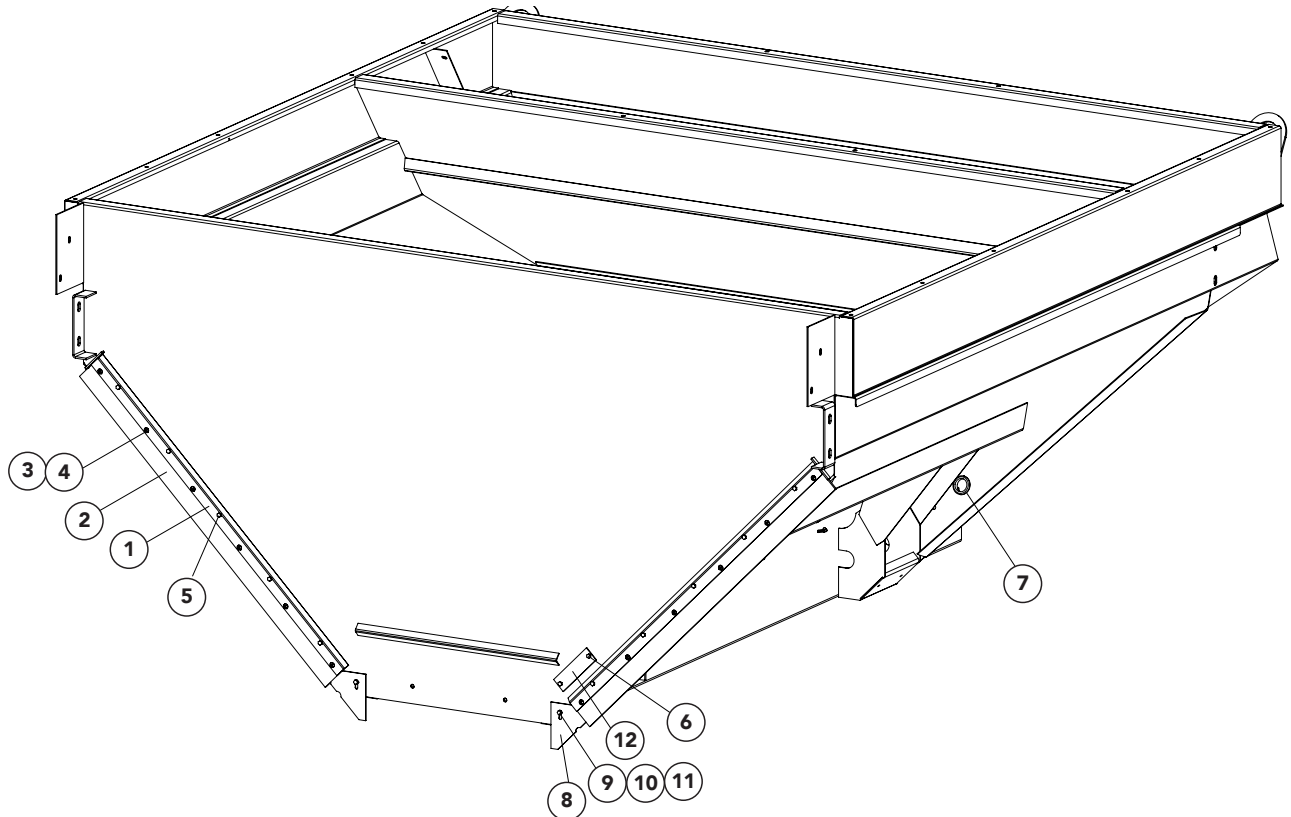

<u>ITEM</u>	<u>PART NO.</u>	<u>DESCRIPTION</u>	<u>QTY</u>
	306637	Seal - Assy, Includes 1-4	
1	306581	Retainer - Seal 304	2
2	306582	Seal - 3 x 1/4 x 45	2
3	56258	Screw - Truss Head 1/4-20NC x 1/2 SS	12
4	88931	Nut - Tee 1/4 x 1/4	12
5	36395	Cap Screw - 1/4-20NC x 1 SS	10
6	36393	Cap Screw - 1/4-20NC x 3/4 SS	2
7	34129	Grommet - Rubber	1
8	306707	Sealer - Endgate Bolt-In 304	2
9	36418	Washer - Lock 1/4 SS	2
10	40750	Cap Screw - 1/4-20NC x 1-1/4 SS	2
11	36423	Washer - Flat 1/4 SS	2
12	307125	Plate - Bin Sensor 304	1

Hillside Divider & Cover - Style I

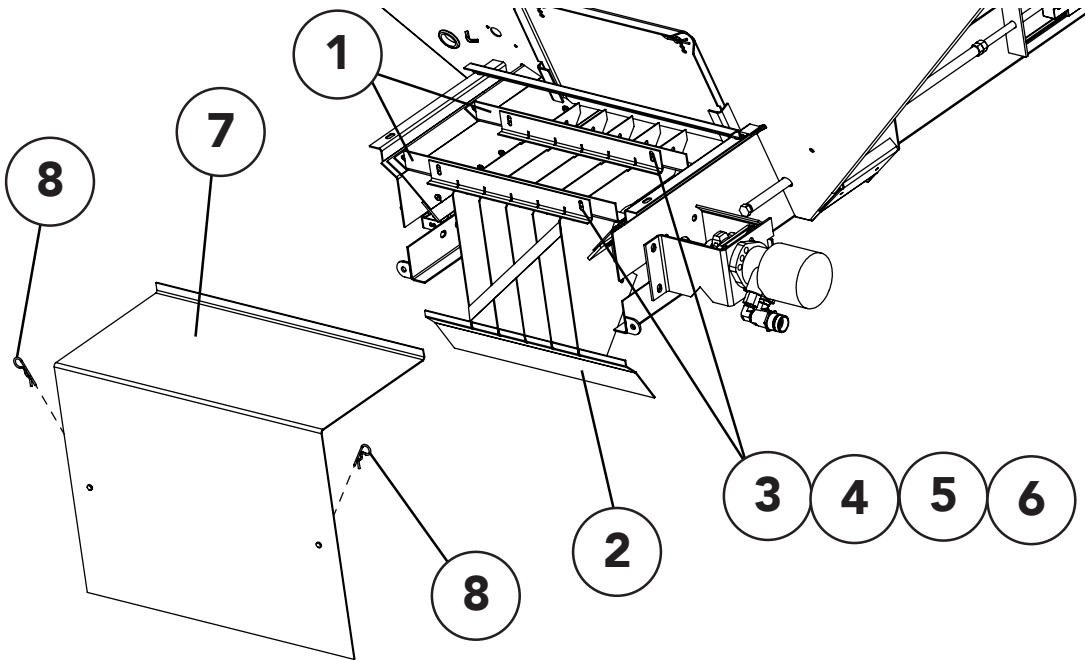

<u>ITEM</u>	<u>PART NO.</u>	<u>DESCRIPTION</u>	<u>QTY</u>
1	86825	Support - Divider	2
2	98553	Divider - Wldmt Hillside	1
3	36408	Bolt - Carriage 3/8-16 NC x 1	4
4	36425	Washer - Flat 3/8	4
5	36420	Washer - Lock 3/8	4
6	36414	Nut - Hex 3/8-16 NC	4
7	98562	Cover - Wldmt Rear 304	1
8	36429	Pin - Hair	2

Note: Use chain shield hardware to attach Item 1 to sills.

Hillside Divider & Cover - Style II

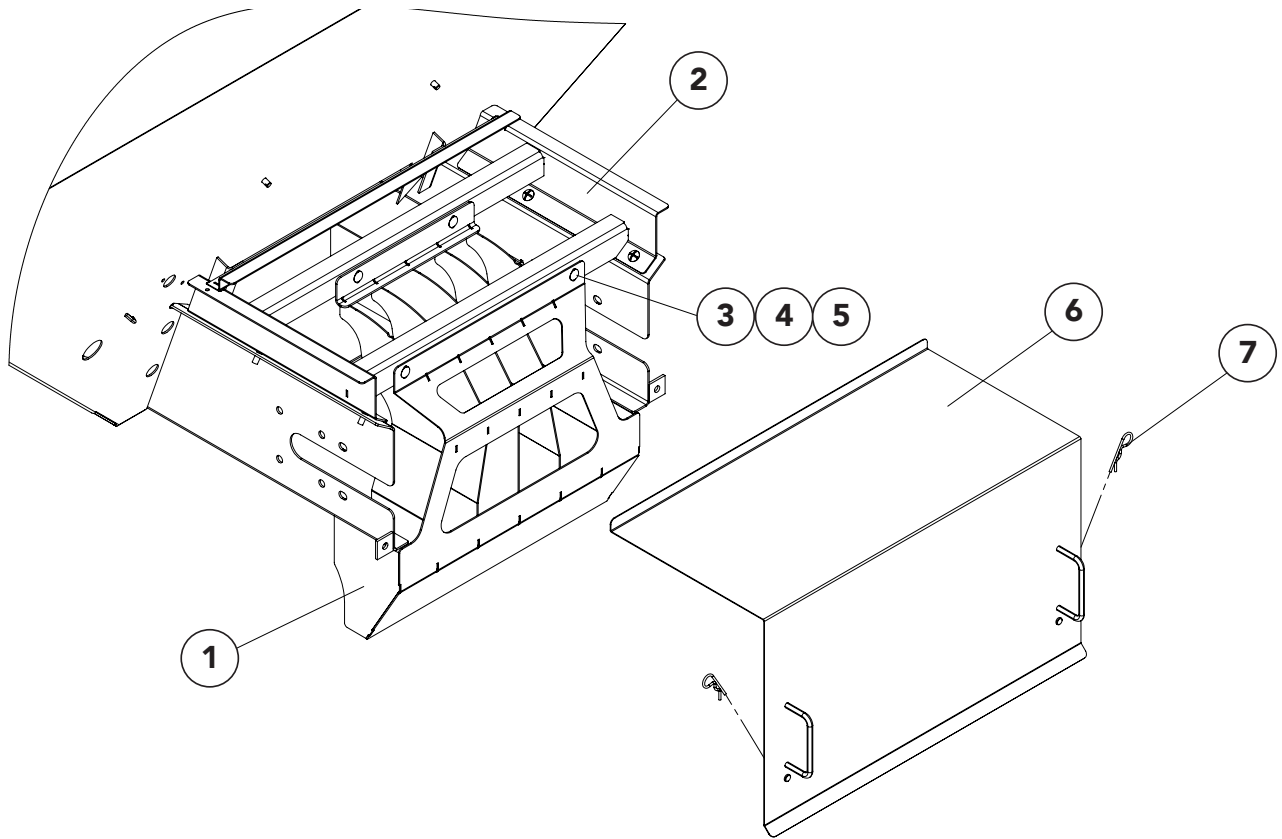

<u>ITEM</u>	<u>PART NO.</u>	<u>DESCRIPTION</u>	<u>QTY</u>
1	311428	Hillside Divider Wldmt 304	1
2	311438	Support - Hillside Divider Wldmt 304	1
3	36408	Bolt - Carriage 3/8-16NC x 1 SS	4
4	36425	Washer - Flat 3/8 SS	4
5	72054	Nut - Lock 3/8-16NC SS	4
6	311444	Cover - Wldmt Rear 304	1
7	36429	Pin - Hair	2

#4 Belt-Over-chain Conveyor

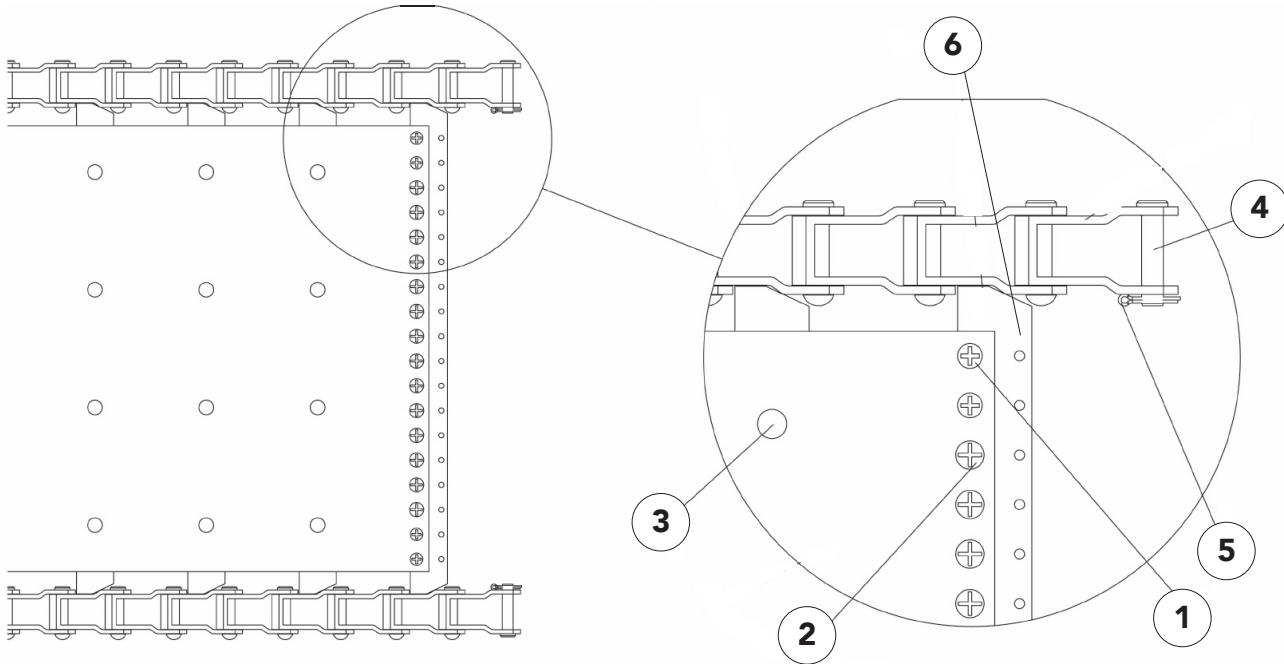

<u>ITEM</u>	<u>PART NO.</u>	<u>DESCRIPTION</u>	<u>QTY</u>
	308712-AA	Chain Wldmt - 5', Includes Items 1 - 6	1
	308712-AC	Chain Wldmt - 7', Includes Items 1 - 6	1
1	20617	Screw - Flat 1/4-20NC x 1/2	8
2	20624	Screw - Truss Head 1/4-20NC x 1/2	28
3	308534	Screw - 1/4 x 1/2-20NC	AR
4	21118	Pin - Chain Pintle	2
5	20817	Pin - Cotter	2
6	70473	Bar - Splicer	1

Chain Shields

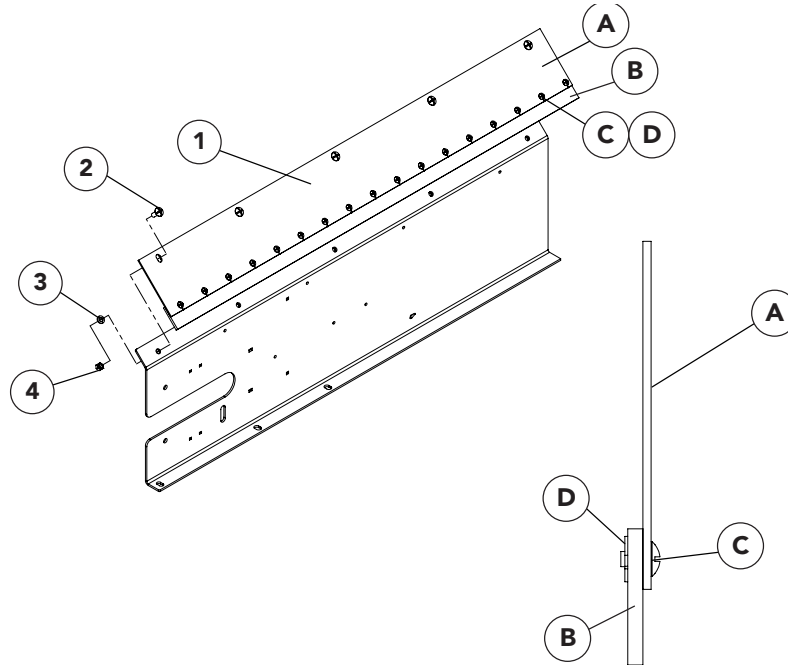

<u>ITEM</u>	<u>PART NO.</u>	<u>DESCRIPTION</u>	<u>QTY</u>
1	86876	Shield – Chain Assy - 5' Unit	2
	303977	Shield – Chain Assy - 7' Unit	2
A	86798	Shield – Chain - 5' Unit	2
	303978	Shield – Chain - 7' Unit	2
B	305975	Belting – Sealer, specify length	AR
C	56258	Screw – Truss Head 1/4-20 x 1/2 - 5' Unit	46
	56258	Screw – Truss Head 1/4-20 x 1/2 - 7' Unit	62
D	88931	Nut – Tee 1/4 x 1/4 - 5' Unit	46
	88931	Nut – Tee 1/4 x 1/4 - 7' Unit	62
2	71829	Screw – Machine 3/8-16 x 1 SS - 5' Unit	14
	71829	Screw – Machine 3/8-16 x 1 SS - 7' Unit	16
3	36420	Washer – Lock 3/8 SS - 5' Unit	14
	36420	Washer – Lock 3/8 SS - 7' Unit	16
4	36414	Nut – Hex 3/8-16 SS - 5' Unit	14
	36414	Nut – Hex 3/8-16 SS - 7' Unit	16

AR – As Required

Conveyor Drive & Encoder

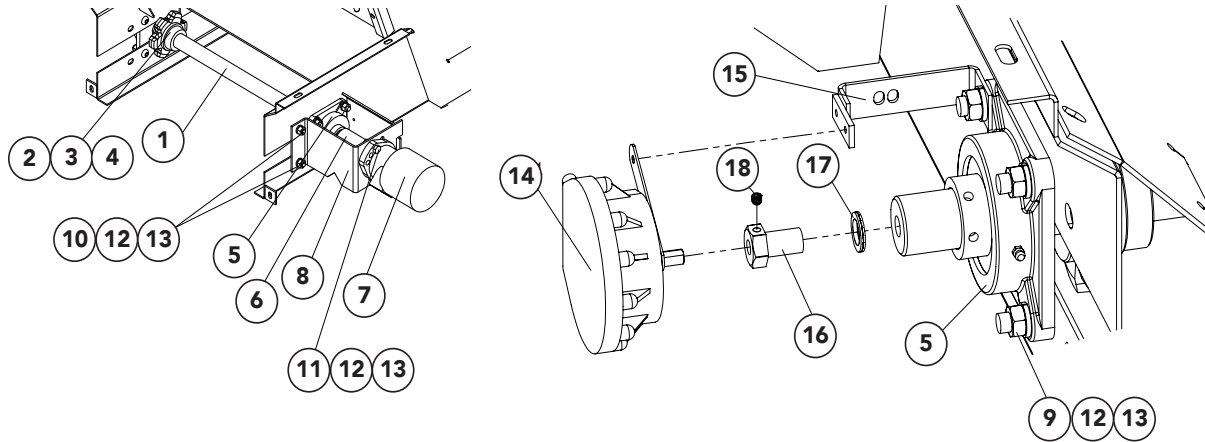

ITEM	PART NO.	DESCRIPTION	QTY
	86759-X1	Shaft - Drive Assy, Includes Items 1-5	
1	310644	Shaft - Drive	1
2	86757	Sprocket	2
3	6131	Key - Square	2
4	20743	Screw - Set	4
5	6697	Bearing	2
6	86762 * 4059	Coupling - Shaft Key - Square 5/16 x 1-1/2	1 1
7	311056 *56327	Motor - Hydraulic 17.1 CID Seal Kit	1 1
8	86766	Mount - Motor	1
9	304484	Screw - Button Head 1/2-13NC x 1-1/2 SS	8
10	72056	Bolt - Carriage 1/2-13NC x 1 SS	2
11	36539	Cap Screw - 1/2-13NC x 1-1/2 SS	2
12	36422	Washer - Lock 1/2 SS	12
13	36416	Nut - Hex 1/2 SS	12
14	303994	Encoder - Conveyor 180	1
15	304953- X1	Bracket - Encoder	1
16	310601	Coupler - Rate Sensor	1
17	310602	Washer - Special Lock	1
18	310603	Screw - Set 1/4-20NC x 5/16 SS	1

* - Not Shown

Idler

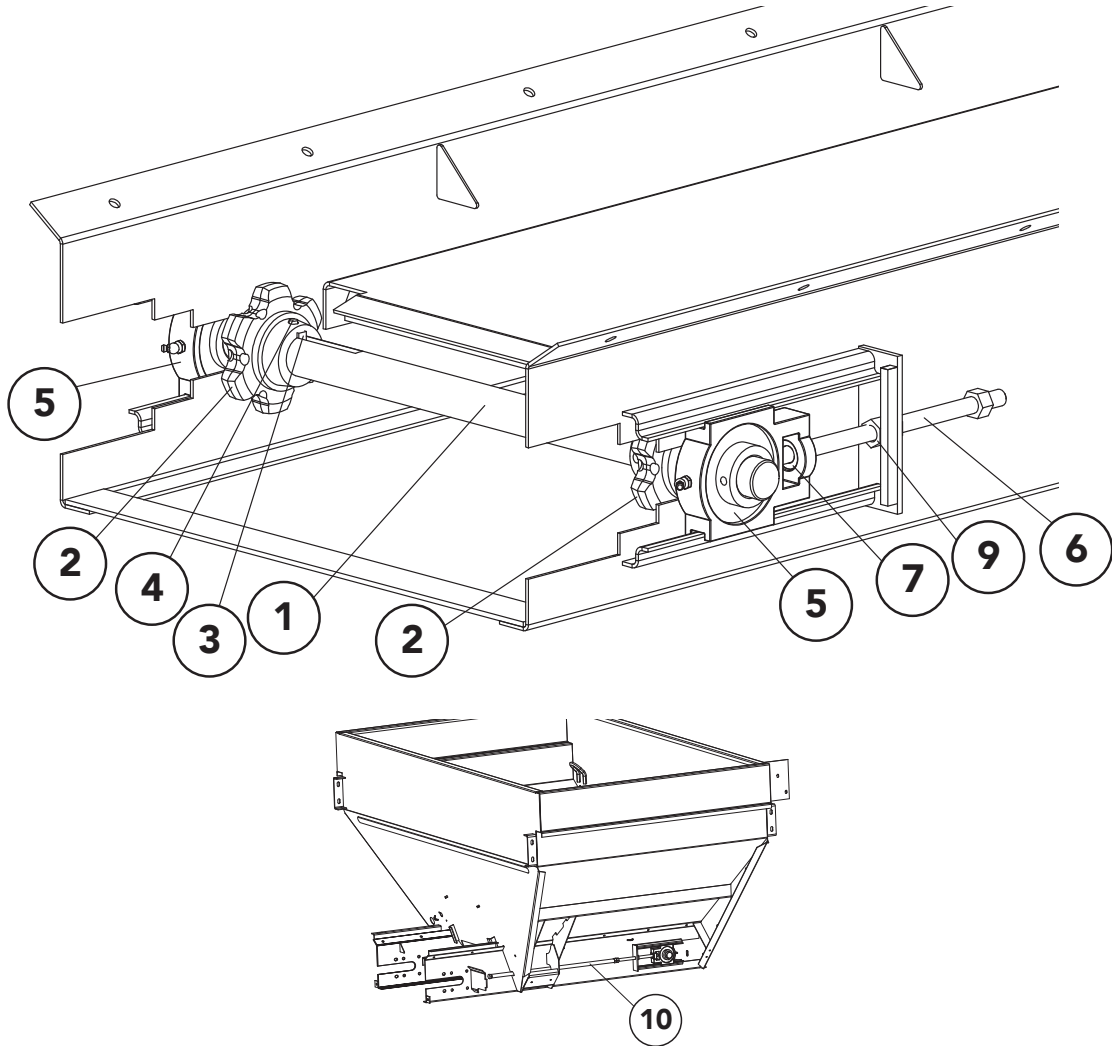

<u>ITEM</u>	<u>PART NO.</u>	<u>DESCRIPTION</u>	<u>QTY</u>
1	89779	Shaft – Idler	1
2	86757	Sprocket	2
3	6131	Key – Square	2
4	20743	Screw – Set 5/16-18NC x 3/8	4
5	22511	Bearing	2
6	87857	Bolt Wldmt	2
7	17078	Collar – Set	2
8	* 36417	Nut – Hex 5/8 SS	2
9	87856	Nut Wldmt 304	2
10	306974	Extended Idler - Pipe Wldmt Adj 5' 304	2
	306595	Extended Idler - Pipe Wldmt Adj 7' 304	2

* - Not Shown

Idler Grease Zerks

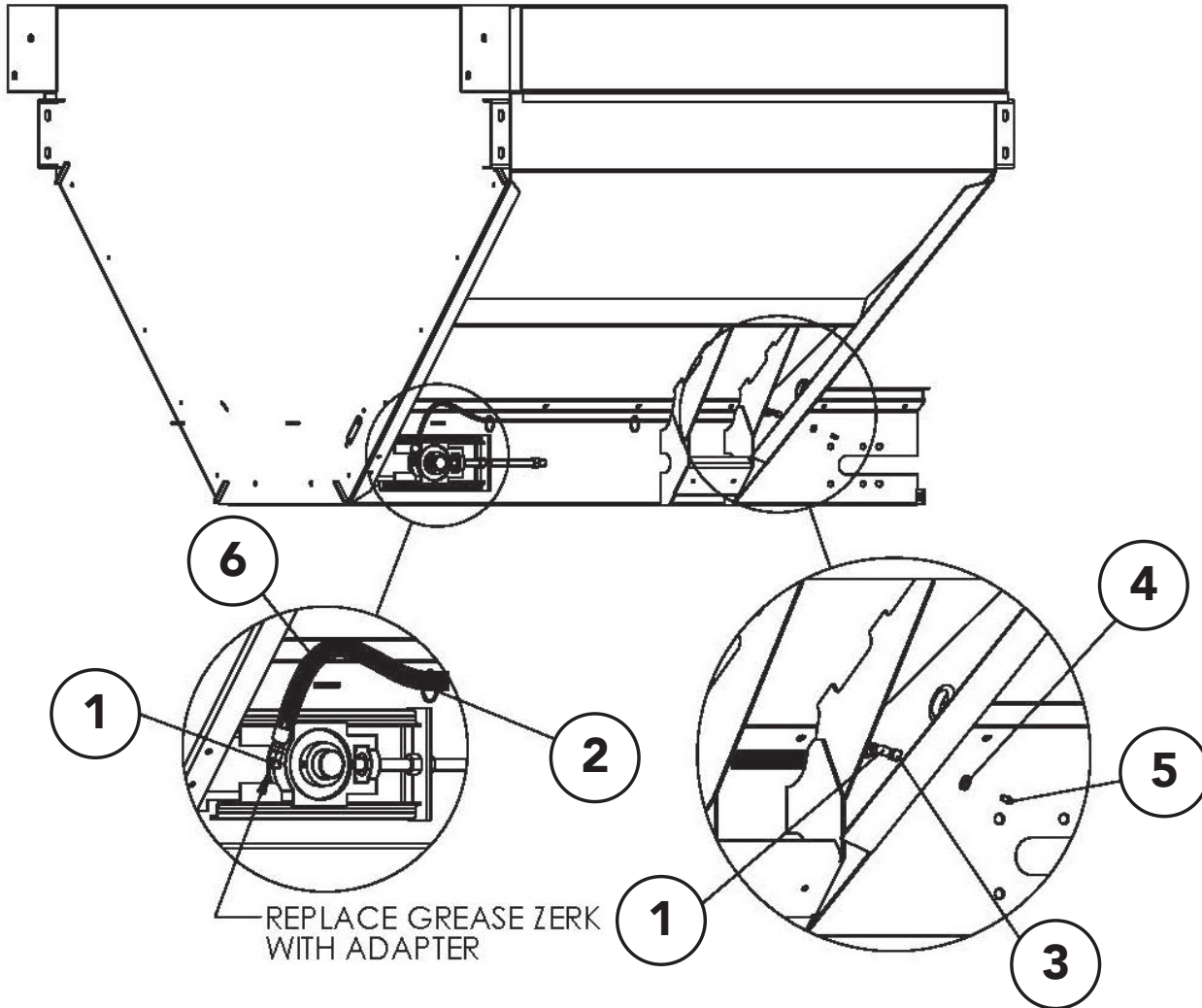

ITEM	PART NO.		DESCRIPTION	QTY
	Style I	Style II		
1	34734	34734	Adapter - Elbow	4
2	99674	311806	Tie - Cable	AR
3	301332	301332	Connector - Bulkhead	2
4	301333	301333	Nut - Lock Connector	2
5	6072	6072	Zerk - Grease	2
6	307131	307131	Hose - Assembly 5'	2
	307128	307128	Hose - Assembly 7'	2

AR - As Required

**MultApplier
Mounts**

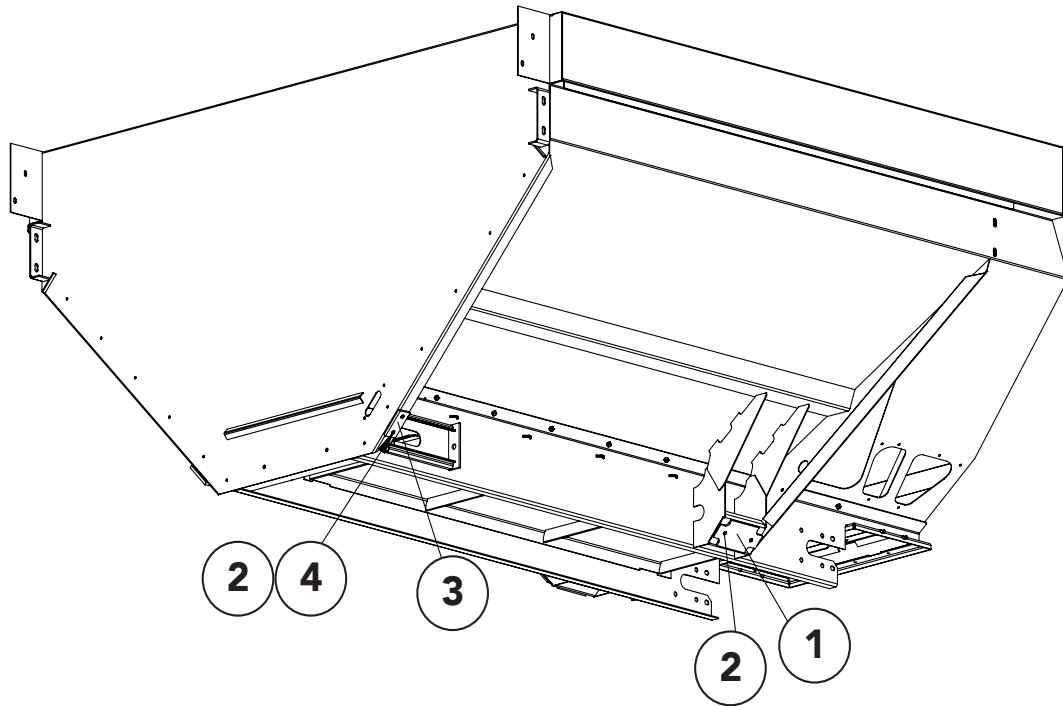

<u>ITEM</u>	<u>PART NO.</u>	<u>DESCRIPTION</u>	<u>QTY</u>
1	306924	Mount - Foot Pad	2
2	47268	Screw - Flathead 1/4-20NC x 1 SS	8
3	307097	Mount - Pad	2
4	42034	Nut - Lock 1/4-20NC SS	4

Hydraulics



<u>ITEM</u>	<u>PART NO.</u>	<u>DESCRIPTION</u>	<u>QTY</u>
1	22020	Fitting - 10-8 Non Standard	1
2	29772	Fitting - 8-10 070220	1
3	34742	Fitting - 8-8 140237	1
4	96651	Disconnect - Quick Female	1
5	96652	Disconnect - Quick Male	1
6	98667	Hose Assembly - 1/2 x 36	1

Hydraulics

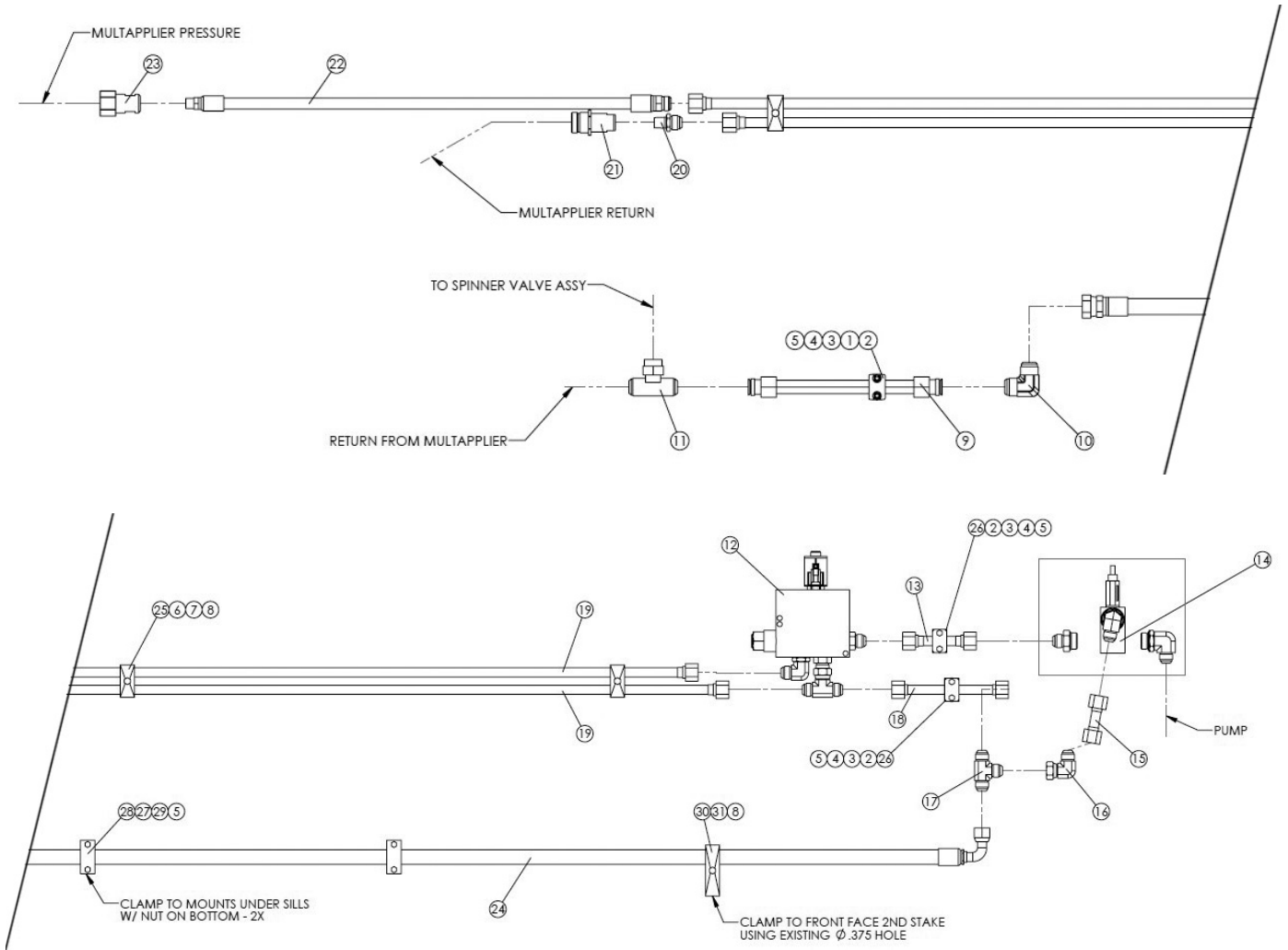

ITEM	PART NO.	DESCRIPTION	QTY
1	86557	Clamp - Tube 1 2pcs=1set	1
2	86556	Plate - Cover Hyd Tube Clamp	3
3	34865	Capscrew - .25-20nc X 2.25 SS	6
4	36423	Washer - Flat .25 SS	6
5	42034	Nut - Lock .25-20nc SS	10
6	71830	Capscrew - .313-18nc X 2.5 SS	3
7	36424	Washer - Flat .313 SS	3
8	42221	Nut - Lock .313-18nc SS	4
9	302436	Tube - Assy 1od X .049 X 14.375 304	1
10	29783	Fitting - 16-16 070201	1
11	34750	Fitting - 16-16-16 070429	1

Hydraulics

12	318274	Valve - Assy	1
13	98644	Tube - Assy .75od X .049 X 5	1
14	98650	Valve - Assy Relief 1500psi	1
15	98643	Tube - Assy .75od X .049 X 2.875 304	1
16	34709	Fitting - 12-12 070221	1
17	29792	Fitting - 12-12-12 070401	1
18	302720	Tube - Assy .75od X .049 X 8.5 304	1
19	98640	Tube - Assy .75od X .049 X 92 13'	2
	98641	TUBE - ASSY .75OD X .049 X 104 14'	2
20	29784	Fitting - 12-8 070102	1
21	96652	Disconnect - Quick Nipple	1
22	98668	Hose - Assy .5od X 36 100r1	1
23	96651	Disconnect - Quick Hex Nut	1
24	305919	Hose - Assy .75 X 87 Return	1
25	75036	Clamp - Tubing Twin .75	3
26	98649	Clamp - Pair .75 Tube	2
27	96926	Clamp - Pair 1.25 Tube	2
28	96925	Plate - Top 1.25 Tube SS	2
29	36396	Capscrew - .25-20nc X 3 SS	4
30	305928	Clamp - Tubing Twin 1.25	1
31	306030	Capscrew - .313-18nc X 3.25 SS	1

Decals

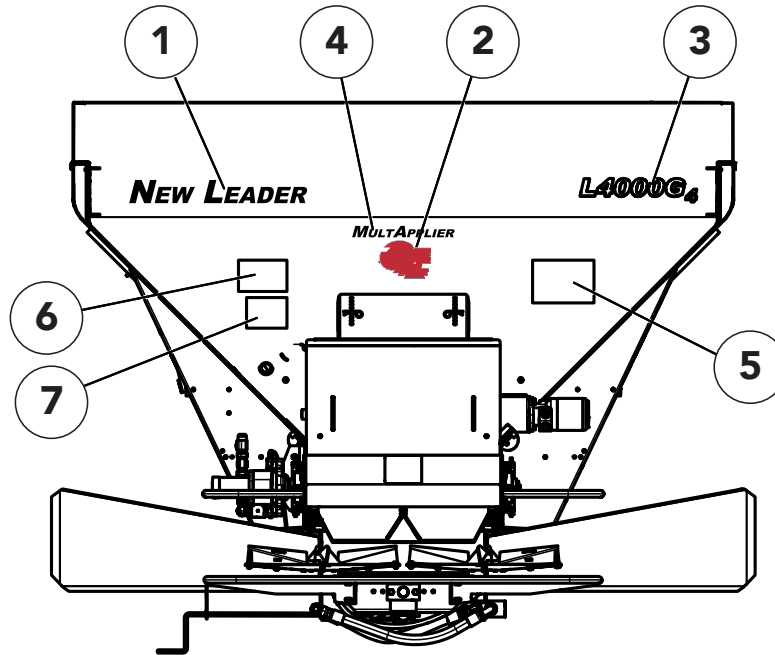

<u>ITEM</u>	<u>PART NO.</u>	<u>DESCRIPTION</u>	<u>QTY</u>
1	312561	Decal - New Leader Black	1
2	87122	Decal - G4	1
3	306151	Decal - L4000G4	1
4	312591	Decal - MULTAPPLIER	1
5	368	Decal - Danger Flying Material	1
6	71526	Decal - Important Spread Pattern	1
7	21476	Decal - Important Chain Life	1

This page is intentionally left blank.

Mounting Hardware

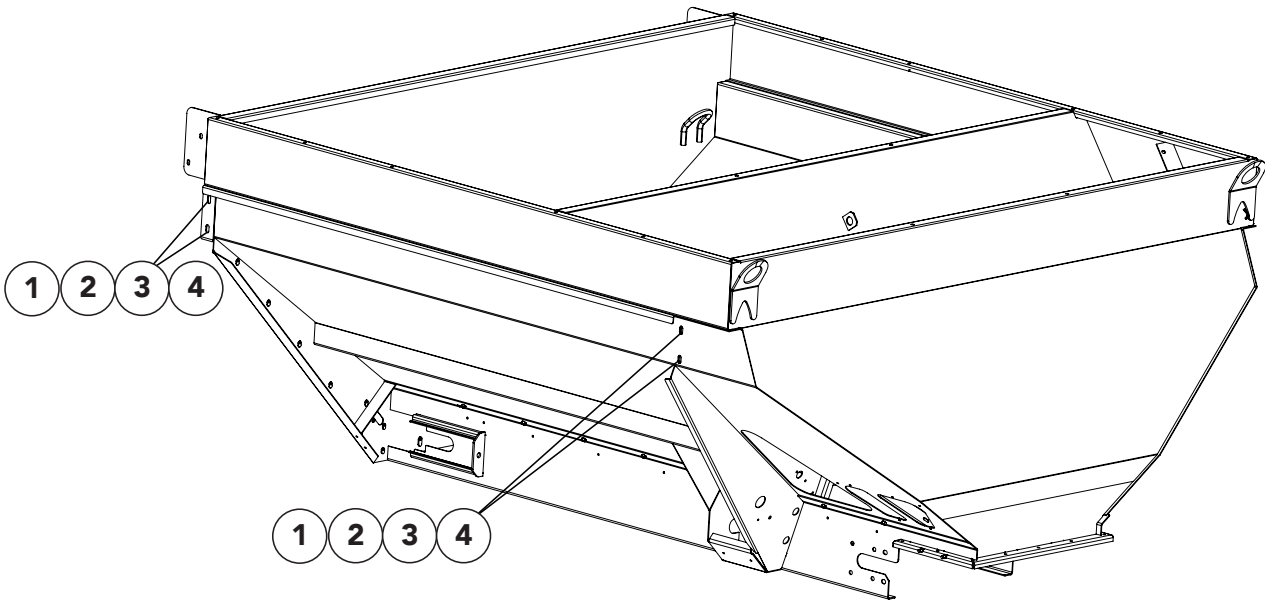

<u>ITEM</u>	<u>PART NO.</u>	<u>DESCRIPTION</u>	<u>QTY</u>
	307129	Hardware – Kit Mount	
2	20129-X1	Cap Screw – 1/2 x 1 1/2 Grade 8	8
3	20695	Washer – Flat 1/2	16
4	20714	Washer – Lock 1/2	8
5	20646	Nut – Hex 1/2	8

Mounting Pads

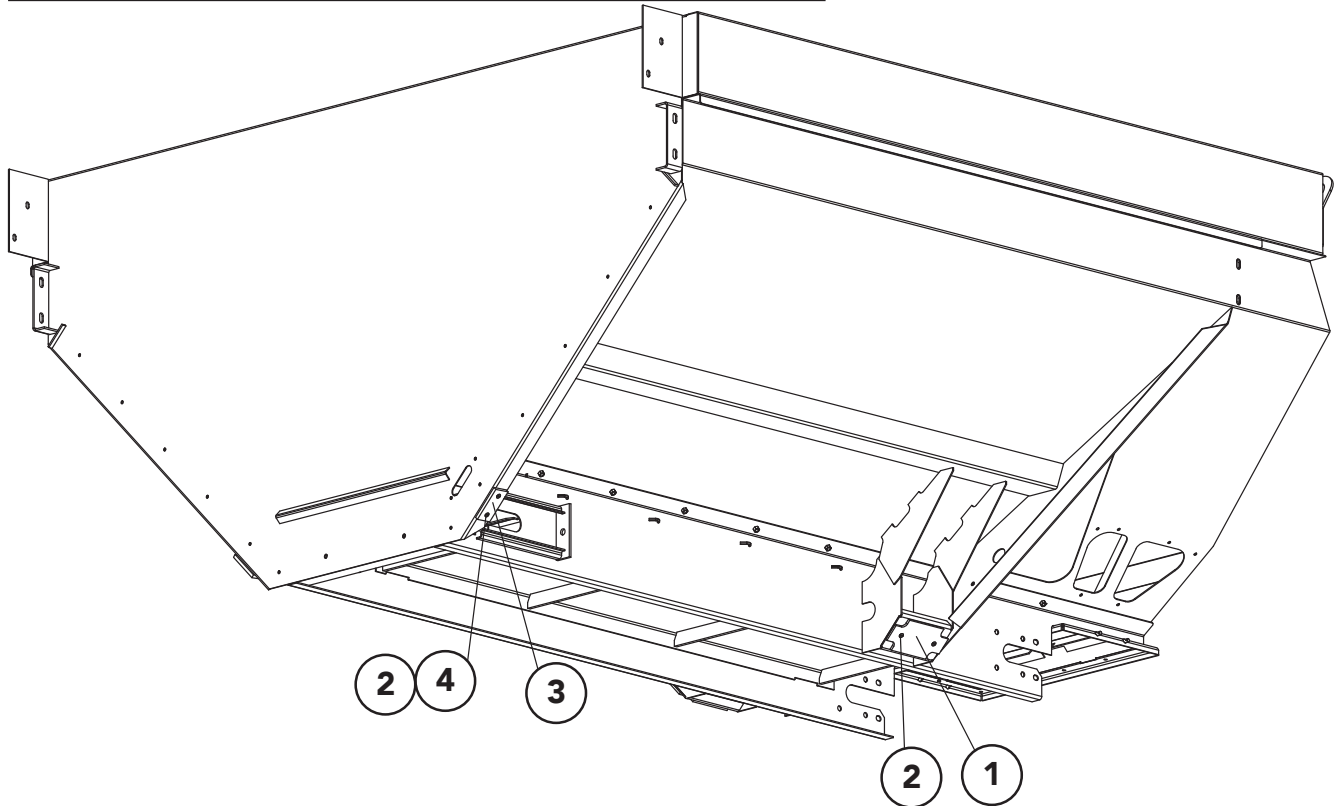

ITEM	PART NO.	DESCRIPTION	QTY
1	306924	Mount - Foot Pad	2
2	47268	Screw - Flathead 1/4-20 x 1 SS	8
3	307097	Mount - Pad	2
4	42034	Nut - Lock 1/4-20 SS	4

Feedgate

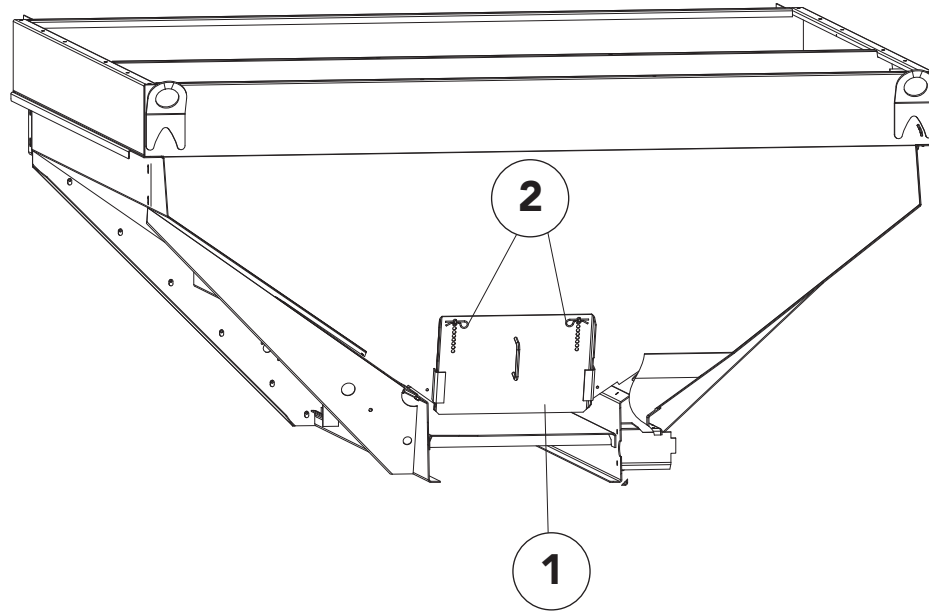

<u>ITEM</u>	<u>PART NO.</u>	<u>DESCRIPTION</u>	<u>QTY</u>
1	306578	Feedgate - Wldmt 304	1
2	36429	Pin - Hair	2

Multibin

Front Feedgate & Wiper

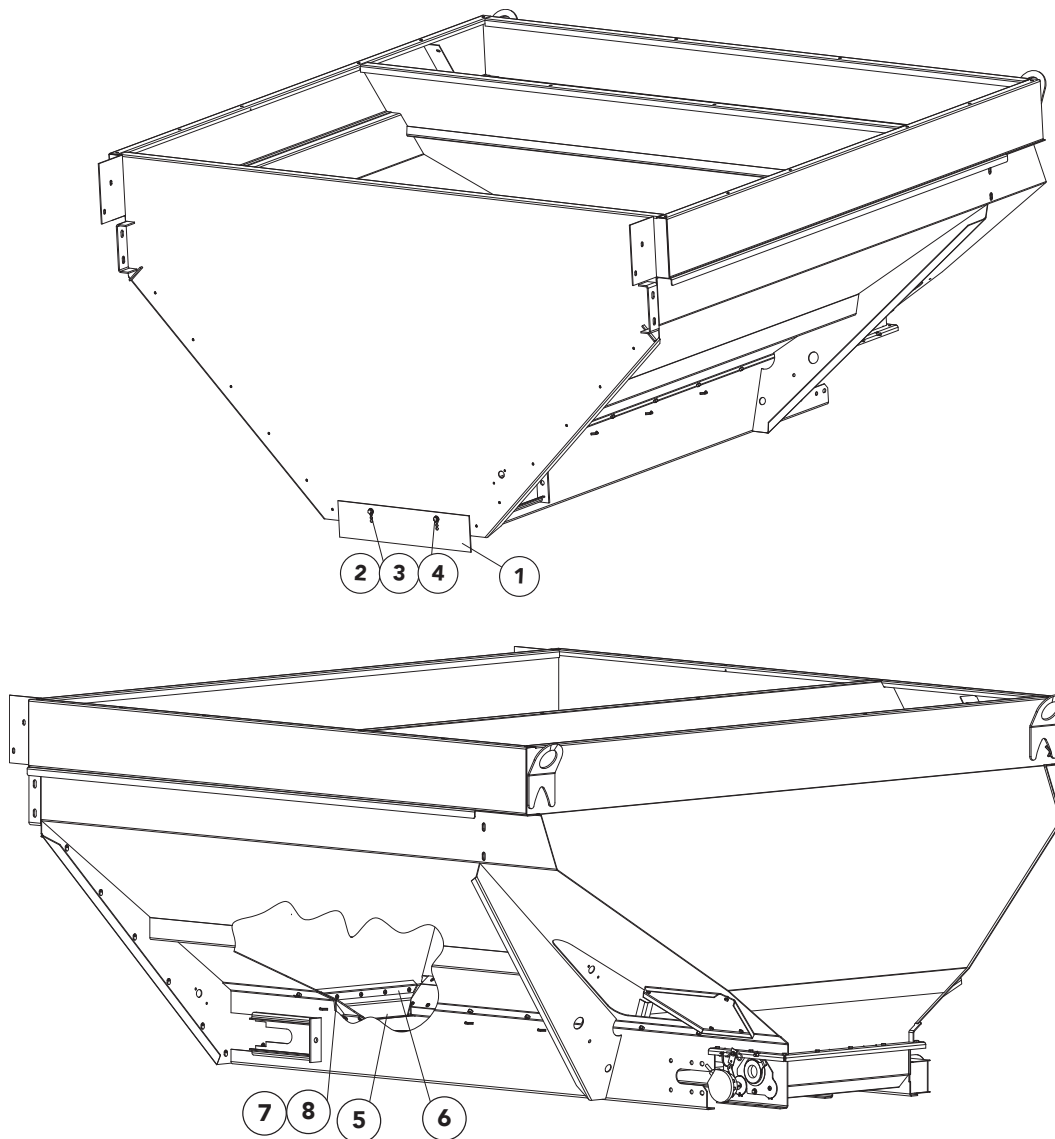

ITEM	PART NO.	DESCRIPTION	QTY
1	306583	Feedgate 304	1
2	36293	Cap Screw - 3/8 x 3/4 SS	2
3	36425	Washer - Flat 3/8 SS	2
4	36420	Washer - Lock 3/8 SS	2
5	306545	Wiper - Belt Front	1
6	306546	Retainer - Wiper 304	1
7	42033	Screw - Truss Head 1/4 x 1 SS	5
8	36412	Nut - Hex 1/4 SS	5

Multibin

Sealer-Front

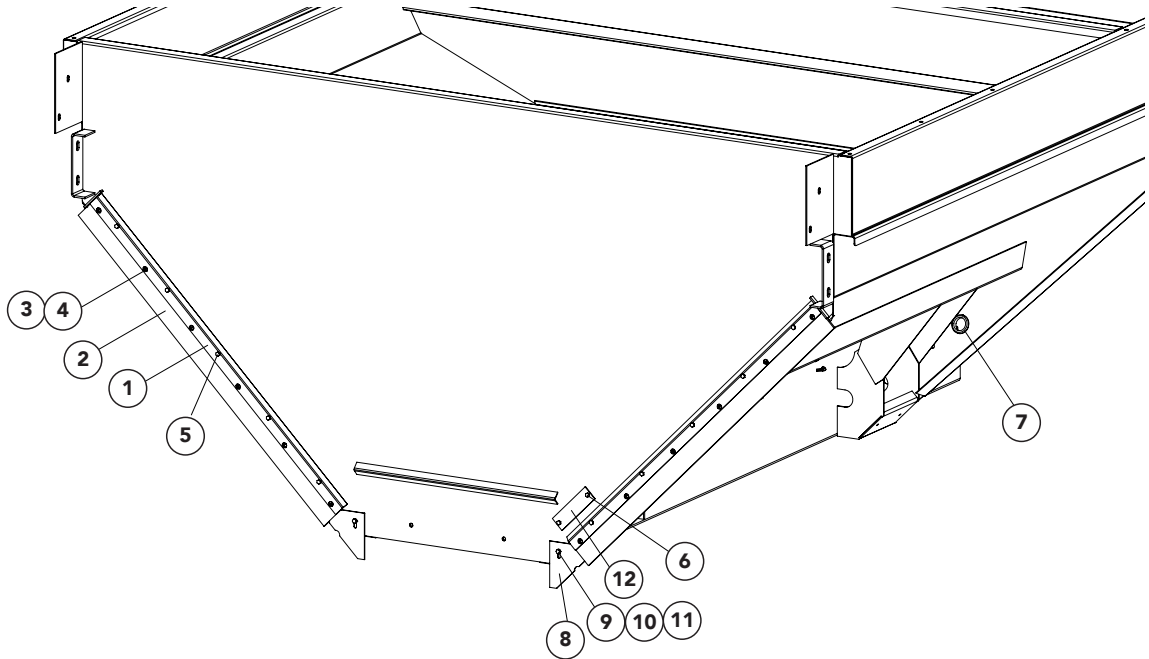

ITEM	PART NO.	DESCRIPTION	QTY
	306637	Seal - Assy, Includes 1-4	
1	306581	Retainer - Seal 304	2
2	306582	Seal - 3 x 1/4 x 45	2
3	56258	Screw - Truss Head 1/4-20NC x 1/2 SS	12
4	88931	Nut - Tee 1/4 x 1/4	12
5	36395	Cap Screw - 1/4-20NC x 1 SS	10
6	36393	Cap Screw - 1/4-20NC x 3/4 SS	2
7	34129	Grommet - Rubber	1
8	306707	Sealer - Endgate Bolt-In 304	2
9	36418	Washer - Lock 1/4 SS	2
10	40750	Cap Screw - 1/4-20NC x 1-1/4 SS	2
11	36423	Washer - Flat 1/4 SS	2
12	307125	Plate - Bin Sensor 304	1

Multibin

#4 Belt-Over-Chain Conveyor

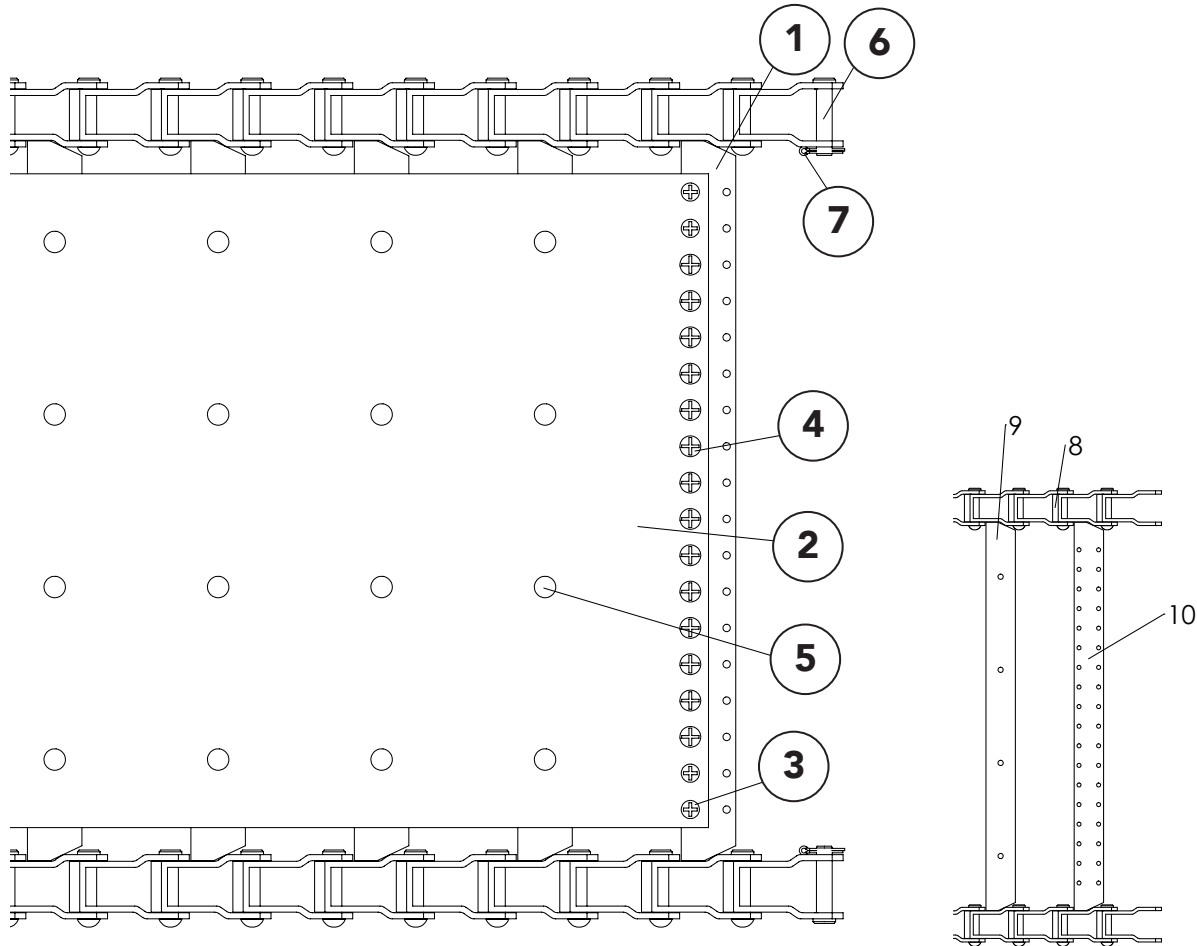

ITEM	PART NO.	DESCRIPTION	QTY
	308712-AC	7' #4 Belt-Over-Chain	
1	308654	Chain - Wldmt #4	1
2	304304-AB	Belt - 18" x 132" MOR	1
3	20617	Screw - Flat 1/4 x 1/2	8
4	20624	Screw - Truss 1/4 x 1/2	28
5	308534	Screw - 1/4-20 x 1/2 #4 BOC	144
6	21118	Pin - Chain Pintle	2
7	20817	Pin - Cotter	2
8	305637	Chain - Assembly 75 Link	2
9	305642	Bar - Cross	36
10	70473	Bar - Splicer	1

Multibin

Conveyor Drive & Encoder

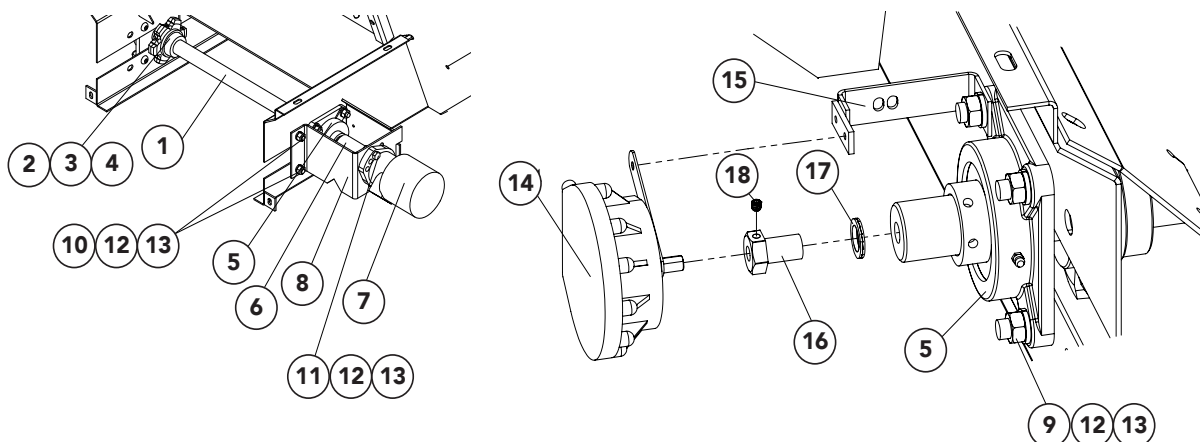

<u>ITEM</u>	<u>PART NO.</u>	<u>DESCRIPTION</u>	<u>QTY</u>
	86759-X1	Shaft - Drive Assy, Includes Items 1-5	
1	310644	Shaft - Drive	1
2	86757	Sprocket	2
3	6131	Key - Square	2
4	20743	Screw - Set	4
5	6697	Bearing	2
6	86762 * 4059	Coupling - Shaft Key - Square 5/16 x 1-1/2	1 1
7	311056 56327	Motor - Hydraulic 17.1 CID Seal Kit	1 1
8	86766	Mount - Motor	1
9	304484	Screw - Button Head 1/2-13NC x 1-1/2 SS	8
10	72056	Bolt - Carriage 1/2-13NC x 1 SS	2
11	36539	Cap Screw - 1/2-13NC x 1-1/2 SS	2
12	36422	Washer - Lock 1/2 SS	12
13	36416	Nut - Hex 1/2 SS	12
14	303994	Encoder - Conveyor 180	1
15	304953- X1	Bracket - Encoder	1
16	310601	Coupler - Rate Sensor	1
17	310602	Washer - Special Lock	1
18	310603	Screw - Set 1/4-20NC x 5/16 SS	1

* - Not Shown

Conveyor Idler

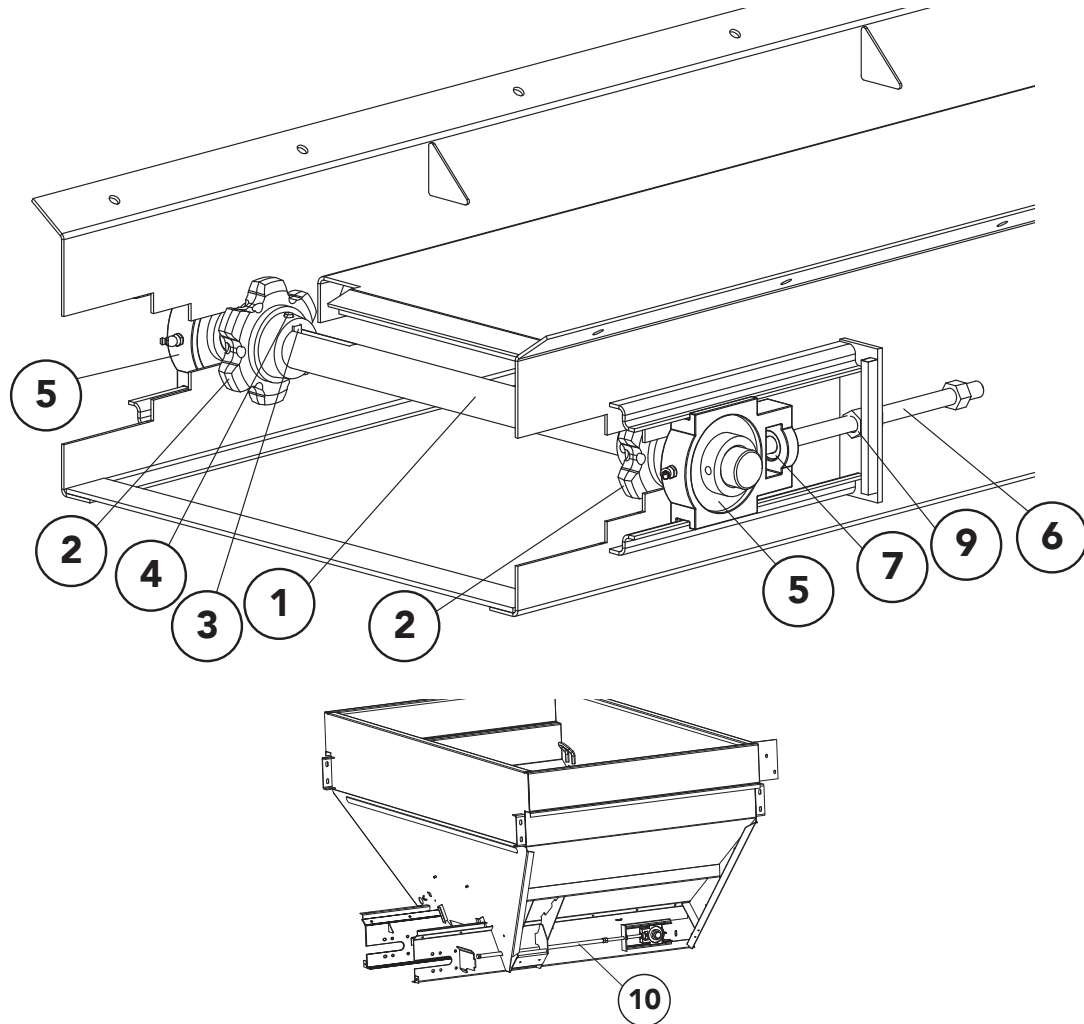

ITEM	PART NO.	DESCRIPTION	QTY
	89780	Shaft - Idler Assy, Includes 1-5	
1	89779	Shaft - Idler	1
2	86757	Sprocket	2
3	6131	Key - Square	2
4	20743	Screw - Set 5/16-18NC x 3/8	4
5	22511	Bearing	2
6	87857	Bolt Wldmt	2
7	17078	Collar - Set	2
8	* 36417	Nut - Hex 5/8 SS	2
9	87856	Nut Wldmt 304	2
10	306595	Extended Idler - Pipe Wldmt Adj 7' 304	2

* - Not Shown

Chain Shields

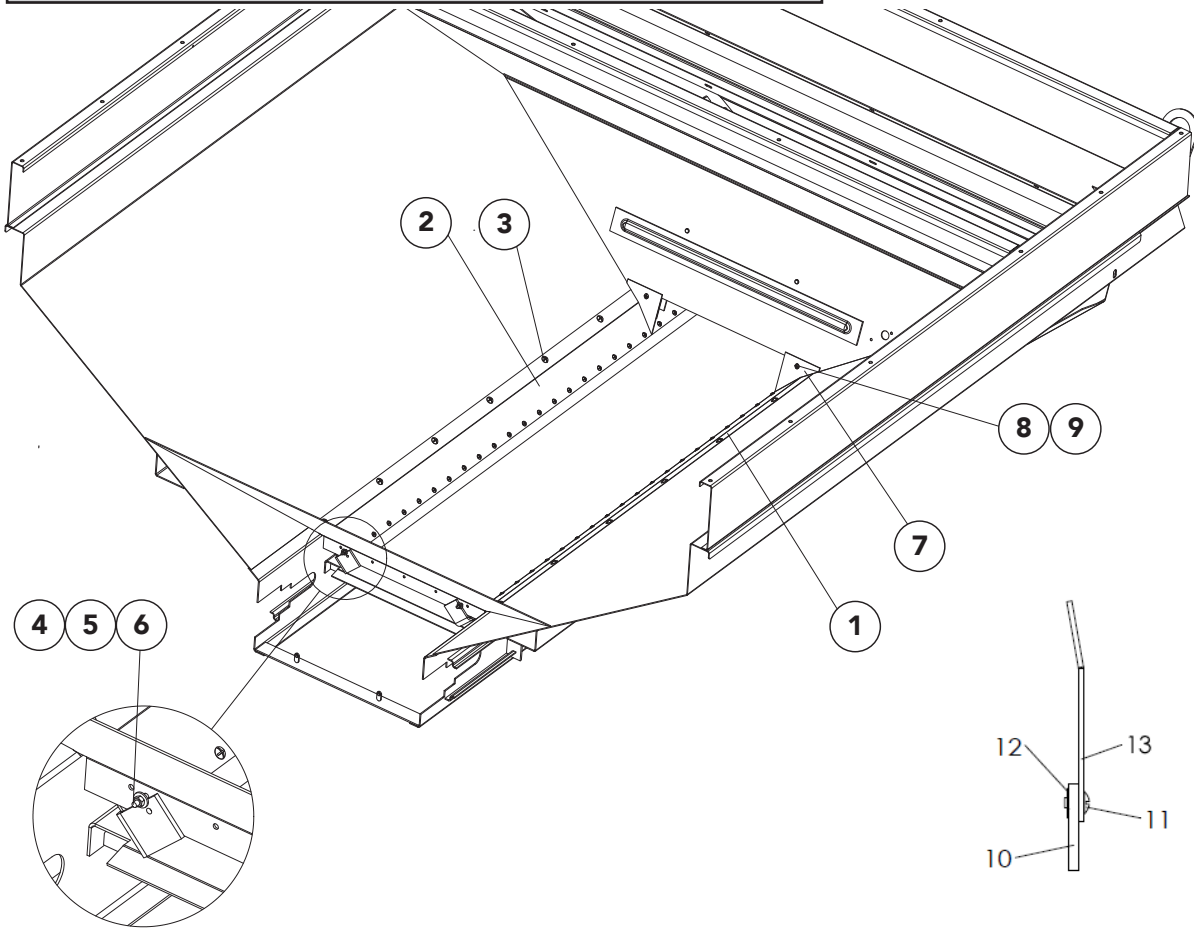

ITEM	PART NO.	DESCRIPTION	QTY
1	306542-AA	Shield - Chain Assy LH 304, Includes 10-13	1
2	306542-AB	Shield - Chain Assy RH 304, Includes 10-13	1
3	71829	Screw - Truss Head 3/8 x 1 SS	16
4	42033	Screw - Truss Head 1/4 x 1 SS	2
5	36423	Washer - Flat 1/4 SS	2
6	36412	Nut - Hex 1/4 SS	2
7	306558	Sealer - Feedgate Bolt-In 304	2
8	32446	Screw - Truss Head 1/4 x 3/4 SS	2
9	42034	Nut - Lock 1/4 SS	2
10	305975	Belting - Sealer Strip MOR	2
11	56258	Screw - Truss Head 1/4-20 x 1/2 SS	54
12	88931	Nut - Tee 1/4 x 1/4	54
13	306543	Shield - Chain 304	2

Divider Panel - Single Micro

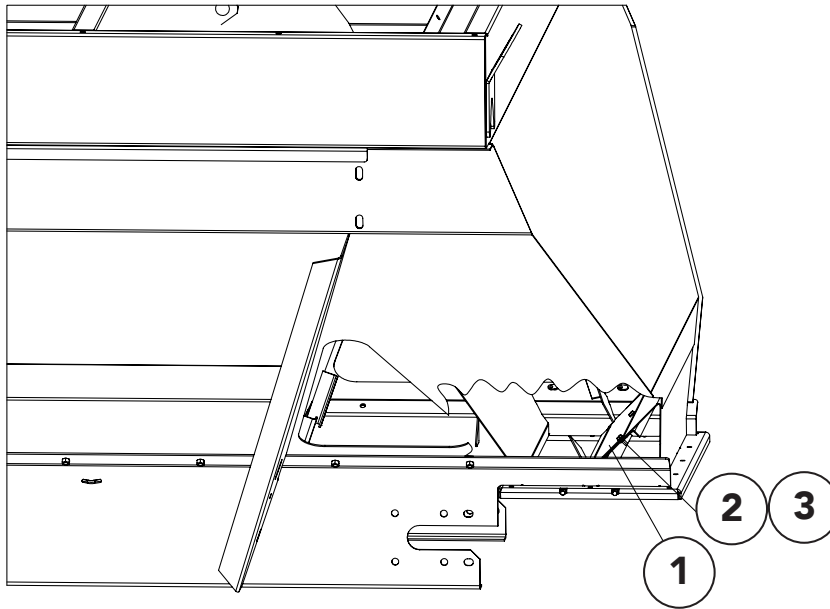

* - Parts removed for clarity.

<u>ITEM</u>	<u>PART NO.</u>	<u>DESCRIPTION</u>	<u>QTY</u>
1	306532	Panel - Weldment Rear 304	1
2	36393	Cap Screw - 1/4-20 x 3/4 SS	3
3	36418	Washer - Lock	3

Divider Panel - Dual Micro

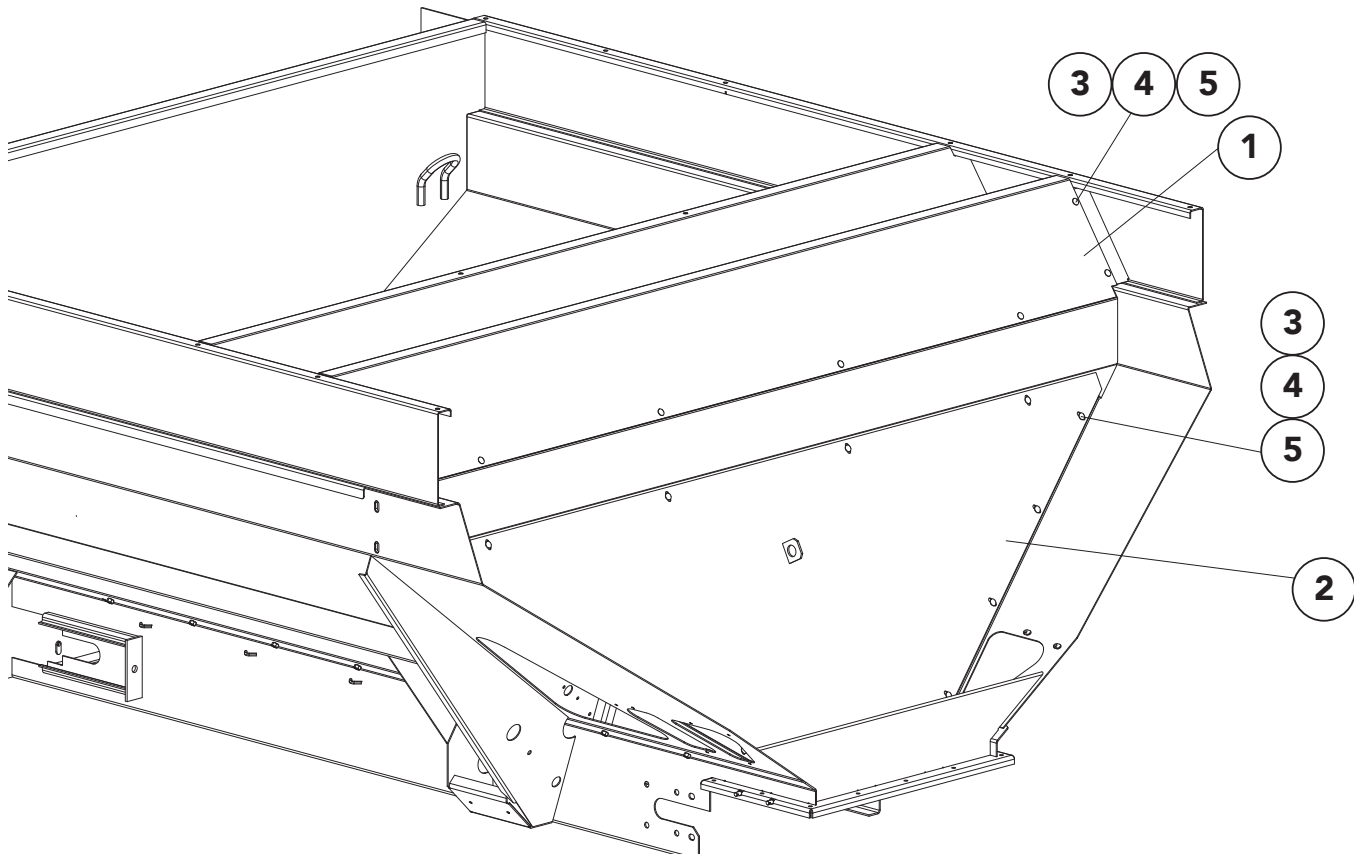

* - Rear Endgate removed for clarity.

<u>ITEM</u>	<u>PART NO.</u>	<u>DESCRIPTION</u>	<u>QTY</u>
1	306528	Panel - Insert Upper 304	1
2	306529	Panel - Weldment Lower 304	1
3	42639	Bolt - Carriage 5/16 x 1 SS	26
4	36424	Washer - Flat 5/16	26
5	42221	Nut - Lock 5/16 SS	26

Hydraulics

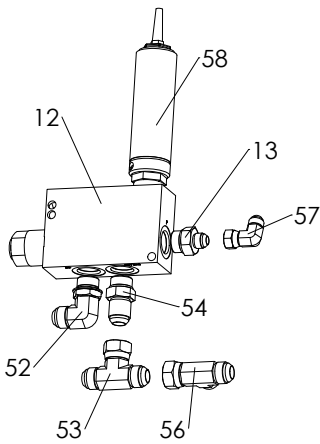
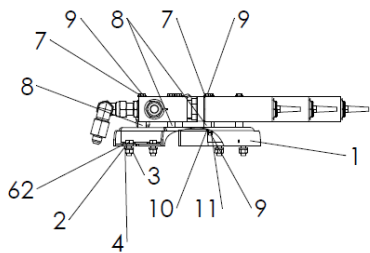
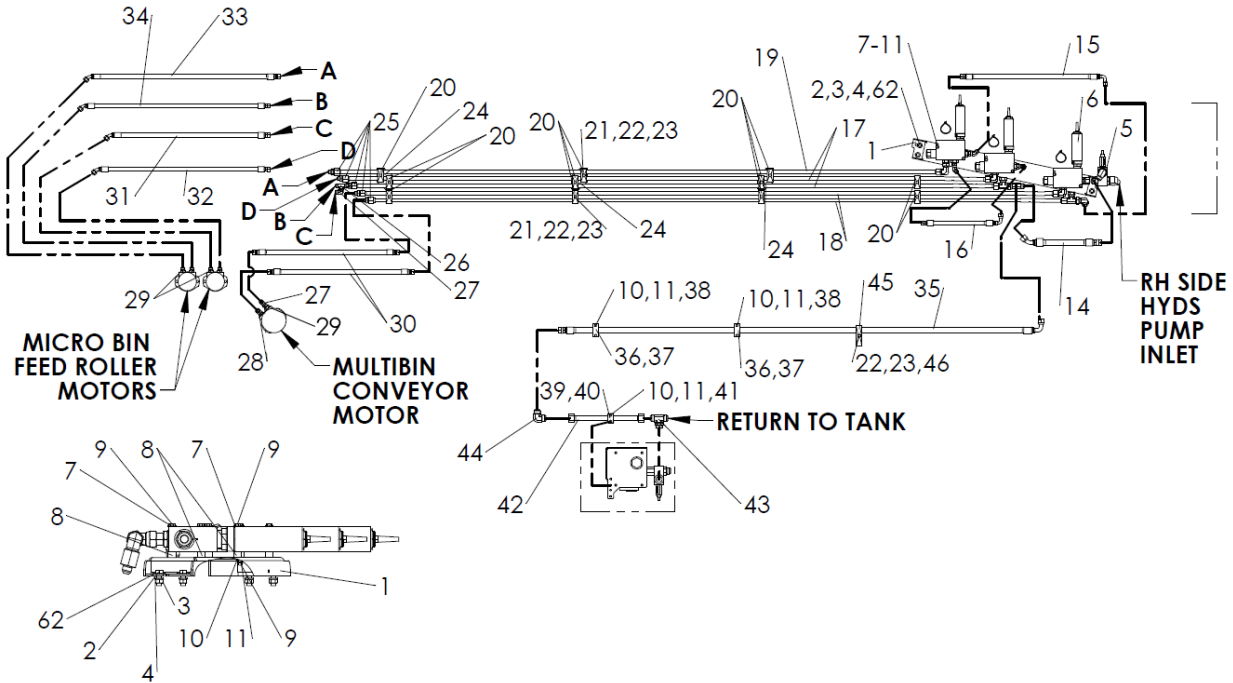

306647 - 5 GPM

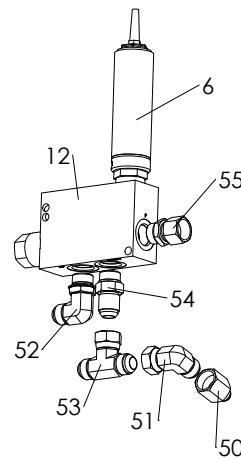

306646 - 9 GPM

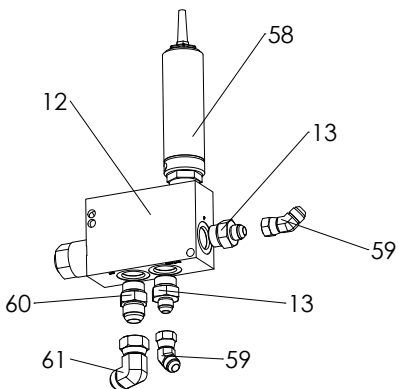

306648 - 5 GPM

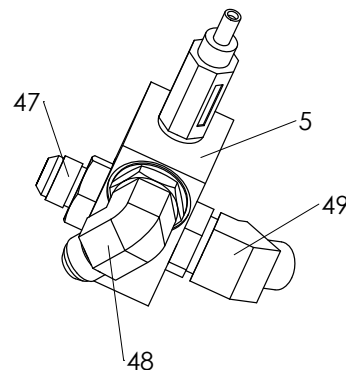

306747 - RELIEF VALVE

Hydraulics

ITEM	PART NO.	DESCRIPTION	QTY
	306646	Valve - Sub-Assembly 9 GPM SFP, Includes 6, 12, 50-55	
	306647	Valve - Sub-Assembly 5 GPM-A SFP Includes 12-13, 52-58	
	306648	Valve - Sub-Assembly 5GPM-B SFP Includes 12-13, 58-61	
	306747	Valve - Relief Assembly 1500 PSI @ 40 GPM Soft Start, Includes 5, 47-49	
	320832	Valve - Control Assembly 5 GPM, Includes 12 & 58	
	320867	Valve - Control Assembly 9 GPM, Includes 6 & 12	
1	306638	Bracket - Valve Mounting	1
2	36398	Cap Screw - 3/8-16 x 1 SS	4
3	36420	Washer - Lock 3/8 SS	4
4	36414	Nut - Hex 3/8-16 SS	4
5	77498	Valve - Relief 1500 PSI	1
6	320428	Valve - Flow Control 9 GPM	1
7	302097	Washer - Step	4
8	302098	Washer - Step	4
9	56396	Cap Screw - 1/4-20 x 3-1/4 SS	4
10	36423	Washer - Flat 1/4 SS	10
11	42034	Nut - Lock 1/4-20 SS	10
12	306274	Manifold - 5-25 GPM SFP	2
13	34842	Fitting - 8-12 070120	2
14	306630	Hose - Return 3/4 x 15-3/4	1
15	80463	Hose - 1/2 100R1 x 39-3/4	1
16	74766	Hose - 1/2 100R1 x 16-3/8	1
17	306642-AA	Tube - 3/4OD x 119-7/16 304	2
	306642-AC	Tube - 3/4OD x 131-7/16 304	2
18	306642-AB	Tube - 3/4OD x 129-15/16 304	2
	306642-AD	Tube - 3/4OD x 141-15/16 304	2
19	306640-AA	Tube 1OD x 111-1/2 304	2
	306640-AB	Tube 1OD x 123-1/2 304	2

* - Not Shown

Hydraulics

ITEM	PART NO.	DESCRIPTION	QTY
20	75036	Clamp - Tubing Twin 3/4	11
21	71830	Cap Screw - 5/16-18 x 2-1/2 SS	11
22	36424	Washer - Flat 5/16	9
23	42221	Nut - Lock 5/16-18 SS	12
24	306639	Bracket - Twin Clamp	3
25	306743	Fitting - 12-8 070101S 304	5
26	306744	Fitting - 8-8-8 070432S 304	1
27	306742	Fitting - 8-8 070221S 304	2
28	306741	Fitting - 8-10 070220S 304	1
29	306740	Fitting - 8-10 070120S 304	5
30	306691	Hose - 1/2 100R1 x 30 SS	2
31	306692	Hose - 1/2 100R1 x 33-51/64 SS	1
32	306695	Hose - 1/2 100R1 x 36-13/32 SS	1
33	306693	Hose - 1/2 100R1 x 40 SS	1
34	306694	Hose - 1/2 100R1 x 39 SS	1
35	306748	Hose - Return 3/4 x 99	1
36	96926	Clamp - Pair 1-1/4 Tube	2
37	96925	Plate - Top 1-1/4 Tube	2
38	36396	Cap Screw - 1/4 x 3 SS	4
39	86557	Clamp - Tube 1"	1
40	86556	Plate - Cover Hydraulic Tube Clamp	1
41	34865	Cap Screw - 1/4-20 x 2-1/4	2
42	302436	Tube - 1OD x 14-3/4 304	1
43	34750	Fitting - 16-16-16 070429	1
44	29783	Fitting - 16-16 070201	1
45	305928	Clamp - Tubing Twin 1-1/4	1
46	306030	Cap Screw - 5/16-18 x 3-1/4 SS	1
47	29835	Fitting - 12-16 070120	1
48	29829	Fitting - 12-16 070220	1
49	56269	Fitting - 12-16 070320	1

* - Not Shown

Hydraulics

<u>ITEM</u>	<u>PART NO.</u>	<u>DESCRIPTION</u>	<u>QTY</u>
50	56406	Fitting - 12-8 070123	1
51	34709	Fitting - 12-12 070221	1
52	29847	Fitting - 12-12 070220	2
53	29809	Fitting - 12-12-12 070433	2
54	303226	Fitting - 12-12 Special STR.	2
55	29788	Fitting - 12-12 S1040-30 Non Standard	1
56	29781	Fitting - 12-12-12 070432	1
57	34803	Fitting - 8-8 070221	1
58	320427	Valve - Flow Control 5	2
59	34805	Fitting - 8-8 070321	2
60	29789	Fitting - 12-12 070120	1
61	34709	Fitting - 12-12 070221	1
62	36425	Washer - Flat 3/8 SS	4
63	*306771	Compound - Antisieze Torque Tight A/G Stainless Steel	AR

* - Not Shown

Idler Zerk

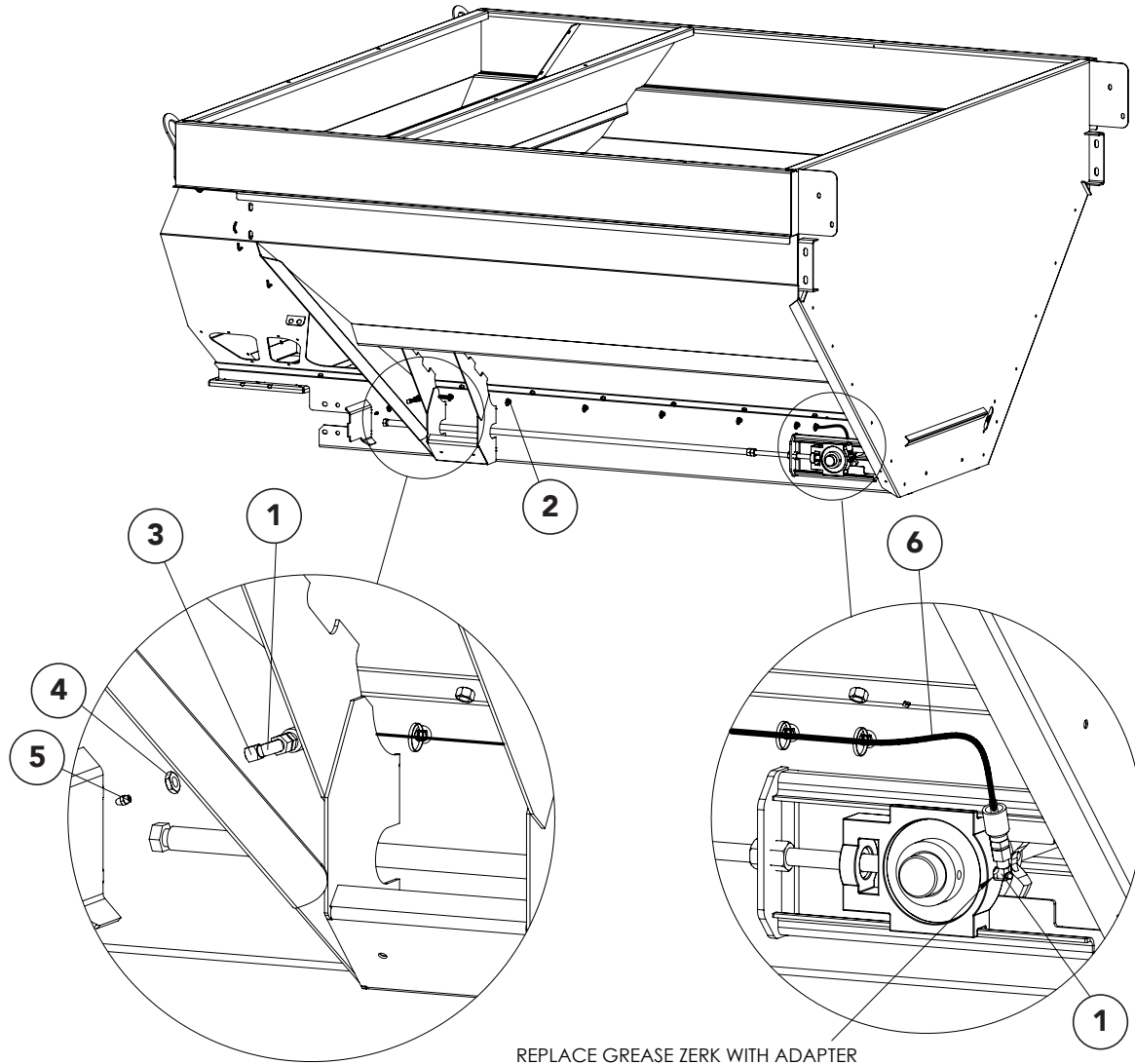

REPLACE GREASE ZERK WITH ADAPTER

ITEM	PART NO.	DESCRIPTION	QTY
1	34734	Adapter - Elbow	2
2	311806	Tie - Cable	8
3	301332	Connector - Bulkhead	2
4	301333	Nut - Lock Connector	2
5	6072	Zerk - Grease	2
6	307128	Hose - Assy 1/4 100R1 x 80	2

Divider

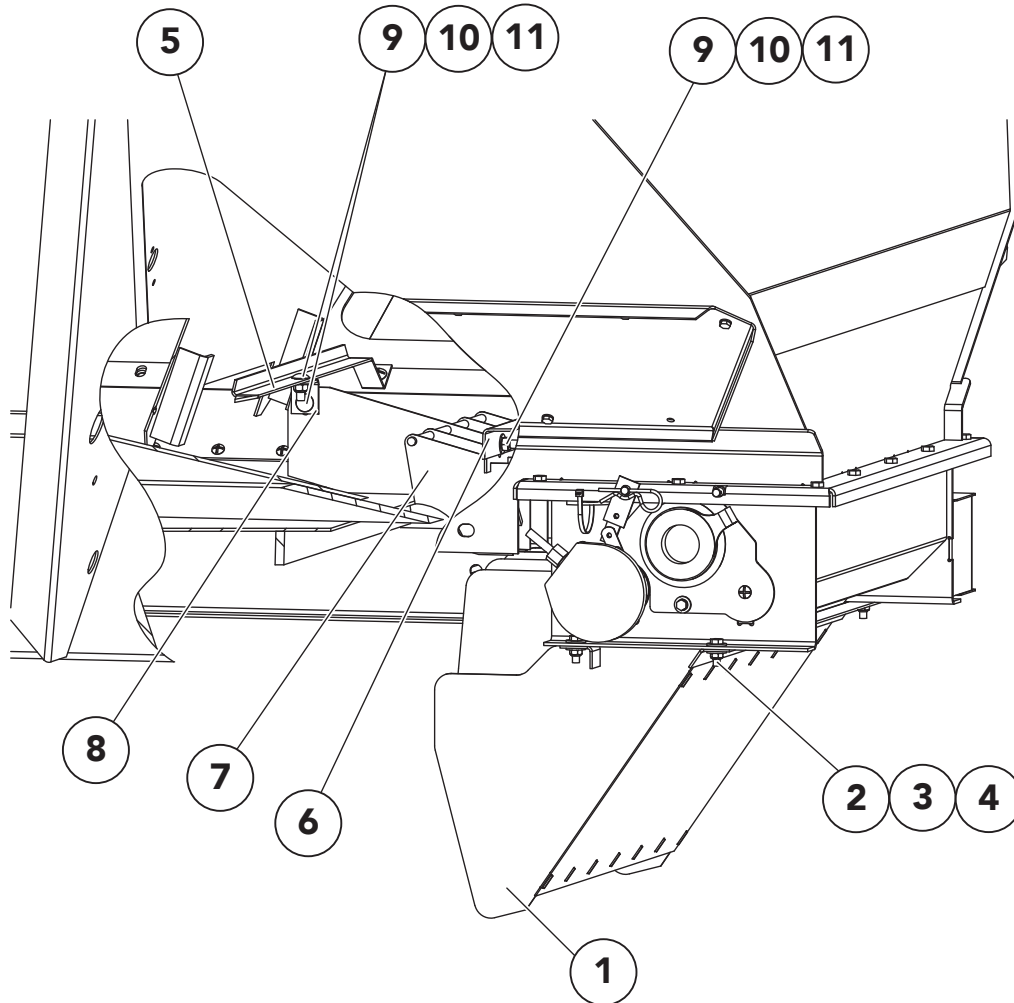

ITEM	PART NO.	DESCRIPTION	QTY
1	306712	Divider - Wldmt Lower 304	1
2	34580	Cap Screw - 5/16 x 1	4
3	36424	Washer - Flat 5/16	8
4	42221	Nut - Lock 5/16 SS	4
5	306576	Support - Divider 304	1
6	306577	Support - Divider 304	1
7	306570	Divider - Wldmt Upper 304	1
8	306575	Clamp - Angle 304	1
9	36408	Bolt - Carriage 3/8 x 1 SS	4
10	36425	Washer - Flat 3/8 SS	4
11	72054	Nut - Lock 3/8 SS	4

Rear Feedgate

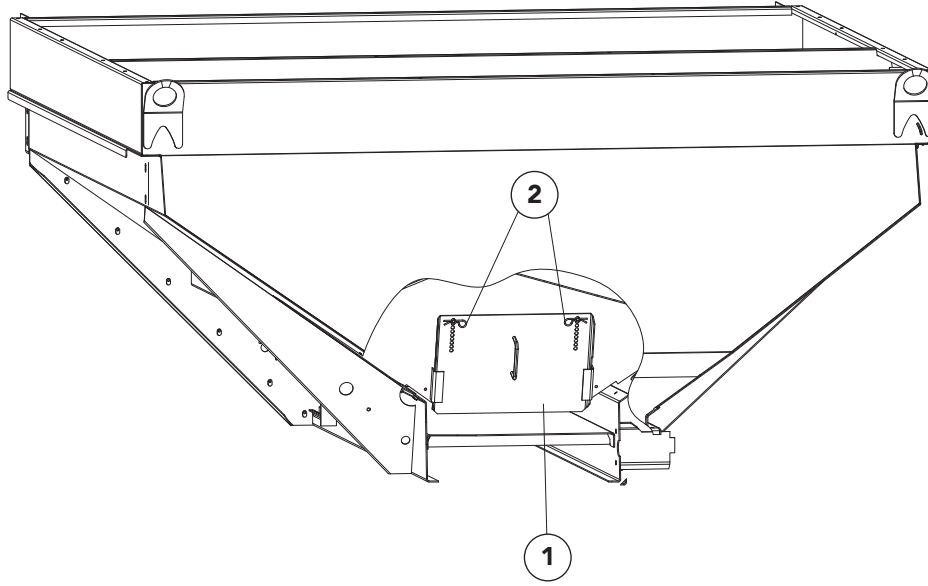

<u>ITEM</u>	<u>PART NO.</u>	<u>DESCRIPTION</u>	<u>QTY</u>
1	306578	Feedgate - Weldment 304	1
2	36429	Pin - Hair	2

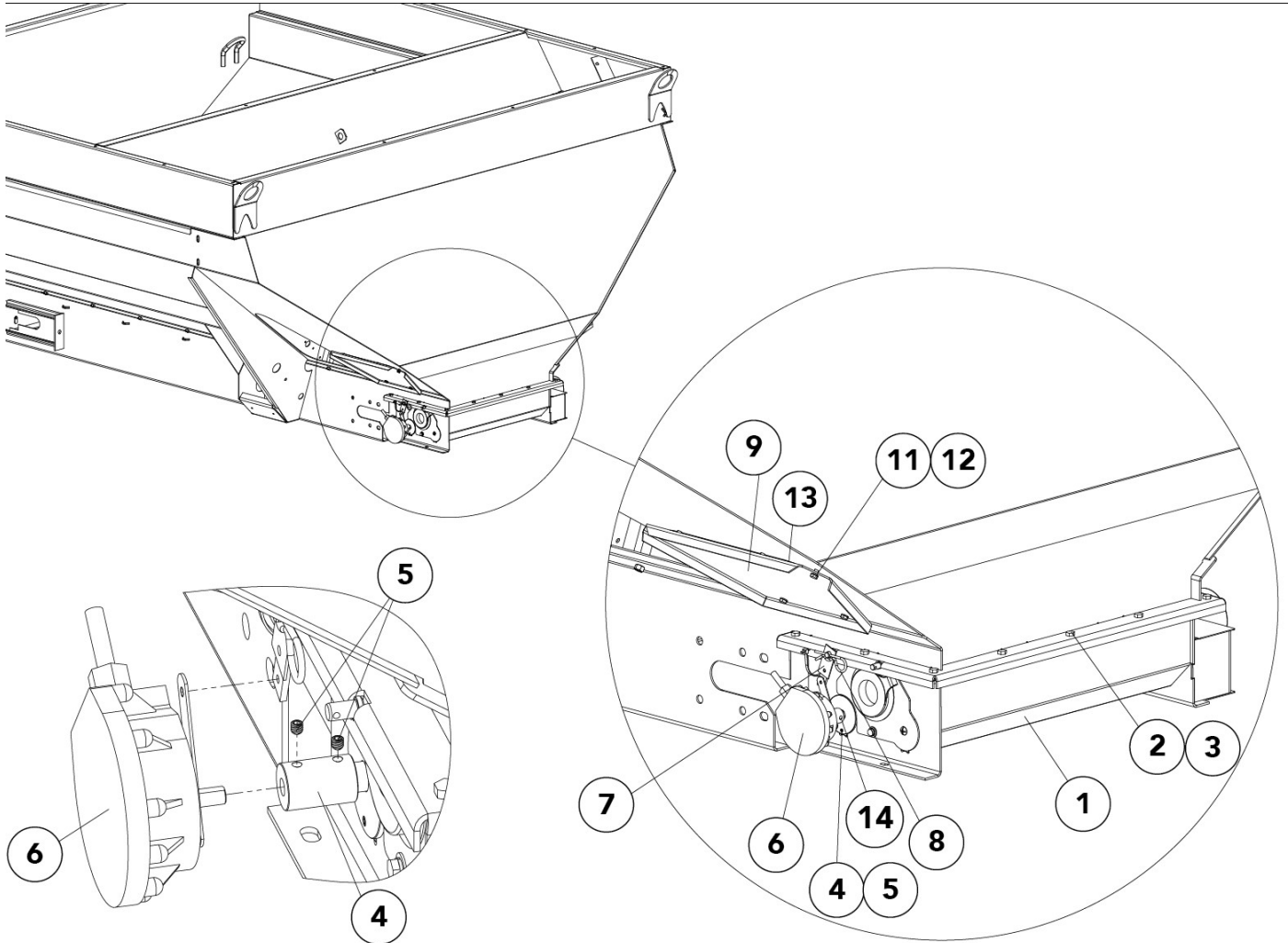

Micro Group

<u>ITEM</u>	<u>PART NO.</u>	<u>DESCRIPTION</u>	<u>QTY</u>
1	306584	Micro - Assembly Single (see next page)	1
	306585	Micro - Assembly Dual (see next page)	1
2	56858	Cap Screw - 5/16 x 3/4	12
3	42221	Nut - Lock 5/16 SS	AR
4	304170	Coupling - Encoder 5/8 Shaft	AR
5	310603	Screw - Set 1/4-20NC X 5/16 SS	AR
6	303994	Encoder - 180 Count DJ with Mount Kit	AR
	303994-AA	Encoder	AR
	303994-AB	Mount - Kit	AR
7	306553	Torque Arm - Encoder 304	AR
8	36429	Pin - Hair	AR
9	306706-AA	Cover - Multibin Access LH 304	1
10	*306706-AB	Cover - Multibin Access RH 304	1
11	36418	Washer - Lock 1/4 SS	12
12	36393	Cap Screw - 1/4 x 3/4 SS	12
13	306819	Seal - Rubber	10 ft.
14	20735	Screw - Set 1/4 x 1/4	AR

* - Not Shown

Micro Assembly-Single

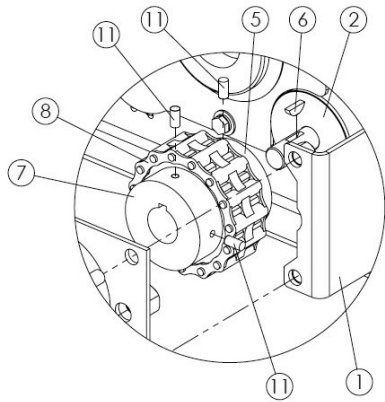

EXPLODED VIEW DETAILING
COUPLING ASSEMBLY

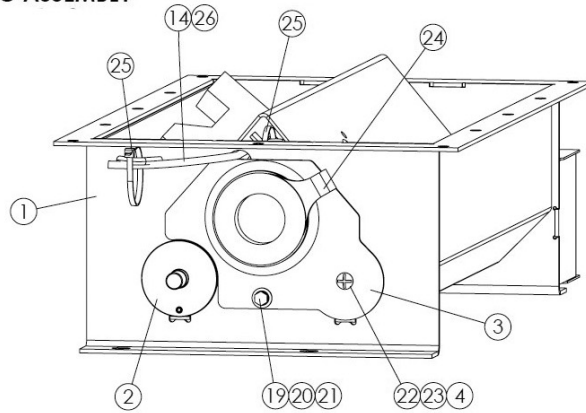
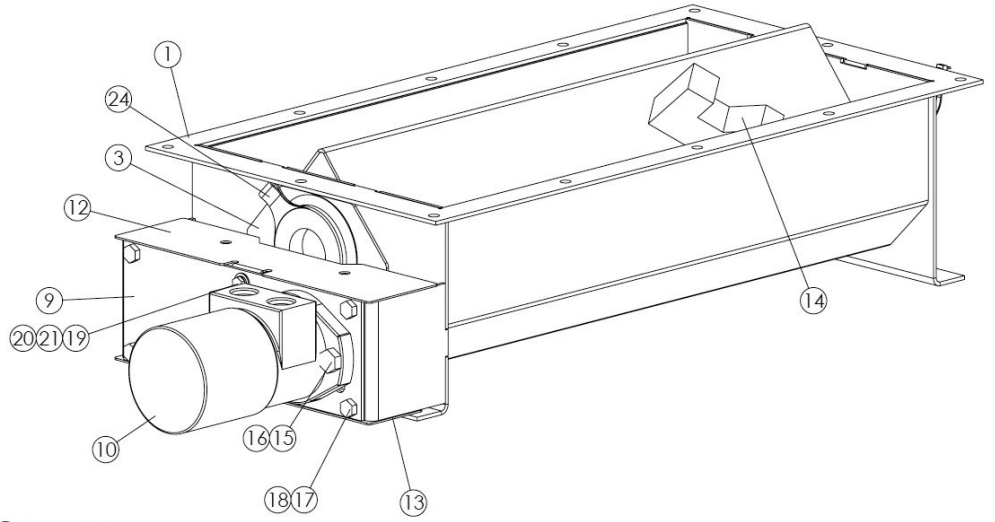

Micro Assembly-Single

<u>ITEM</u>	<u>PART NO.</u>	<u>DESCRIPTION</u>	<u>QTY</u>
	312254	Micro - Assembly Bottom Single 304	
1	306534	Micro - Wldmt Btm 304	1
2	312253	Wheel - Assy Meter Wheels 304	1
3	306555	Retainer - Cover Single 304	2
4	306557	Guide - Retainer 304	2
5	39685	Coupling - Chain Half	1
6	34562	Key - Woodruff .156 X .625	1
7	11409	Coupling - Chain Half 1b X 1/4	1
8	306865	Chain - 304	1
9	306547	Mount - Motor Single 304	1
10	304129	Motor - Hyd 11.9 Cid	1
11	20737	Screw - Set .25-20nc X .5	4
12	306549	Guard - Wldmt Upper 304	1
13	306551	Guard - Wldmt Lower 304	1
14	98787-AB	Sensor - Bin Level Charted	1
15	36539	Capscrew - .5-13nc X 1.5 SS	2
16	39016	Nut - Lock .5-13nc SS	2
17	36398	Capscrew - .375-16nc X 1 SS	4
18	72054	Nut - Lock .375-16nc SS	4
19	36393	Capscrew - .25-20nc X .75 SS	4
20	36423	Washer - Flat .25 SS	4
21	36418	Washer - Lock .25 SS	4
22	32446	Screw - Truss Head .25-20nc X .75 SS	2
23	42034	Nut - Lock .25-20nc SS	2
24	306807	Plug - Inspection	2
25	99674	Strap - Zip Tie 8 Black	4
26	58728	Conduit - 3/8 Split Corrugatd	1.5'

Micro Assembly-Dual

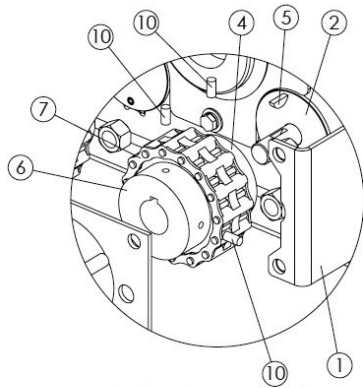

EXPLODED VIEW DETAILING COUPLING ASSEMBLY

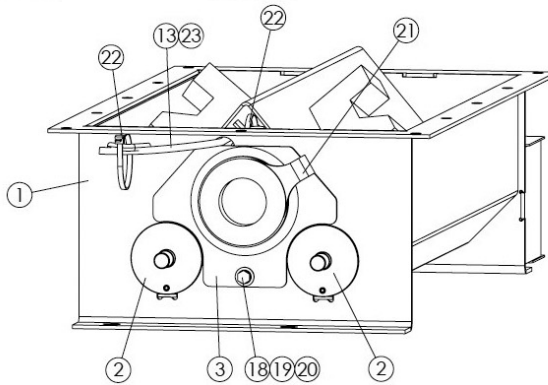
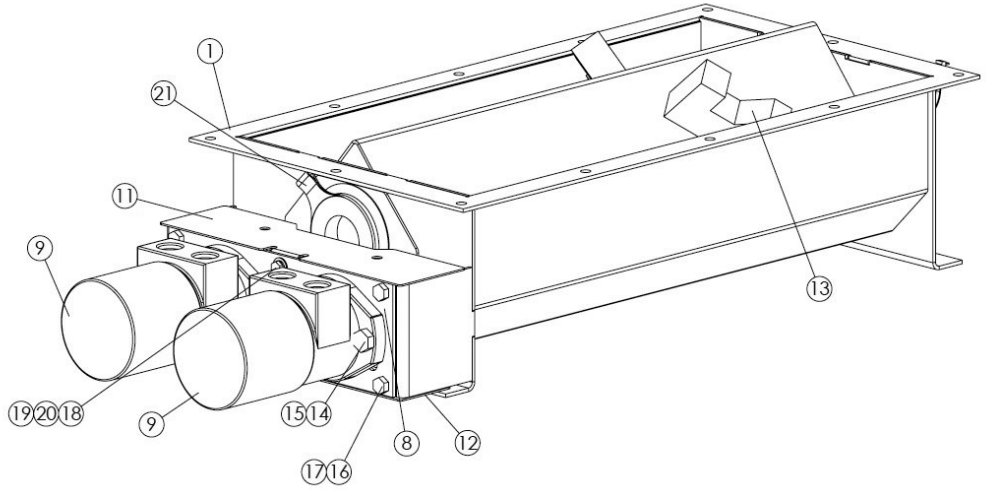

Micro Assembly-Dual

ITEM	PART NO.	DESCRIPTION	QTY
	312255	Micro - Assembly Bottom Dual 304	
1	306534	Micro - Wldmt Btm 304	1
2	312253	Wheel - Assy Meter Wheels 304	2
3	306556	Retainer - Cover Dual 304	2
4	39685	Coupling - Chain Half	2
5	34562	Key - Woodruff .156 X .625	2
6	11409	Coupling - Chain Half 1b X 1/4	2
7	306865	Chain - 304	2
8	306548	Mount - Motor Dual 304	1
9	304129	Motor - Hyd 11.9 Cid	2
10	20737	Screw - Set .25-20nc X .5	8
11	306549	Guard - Wldmt Upper 304	1
12	306551	Guard - Wldmt Lower 304	1
13	98787-AB	Sensor - Bin Level Charted	2
14	36539	Capscrew - .5-13nc X 1.5 SS	4
15	39016	Nut - Lock .5-13nc SS	4
16	36398	Capscrew - .375-16nc X 1 SS	4
17	72054	Nut - Lock .375-16nc SS	4
18	36393	Capscrew - .25-20nc X .75 SS	4
19	36423	Washer - Flat .25 SS	4
20	36418	Washer - Lock .25 SS	4
21	306807	Plug - Inspection	2
22	99674	Strap - Zip Tie 8 Black	2
23	58728	Conduit - 3/8 Split Corrugatd	1.5

Micro Assembly-Meter Wheels

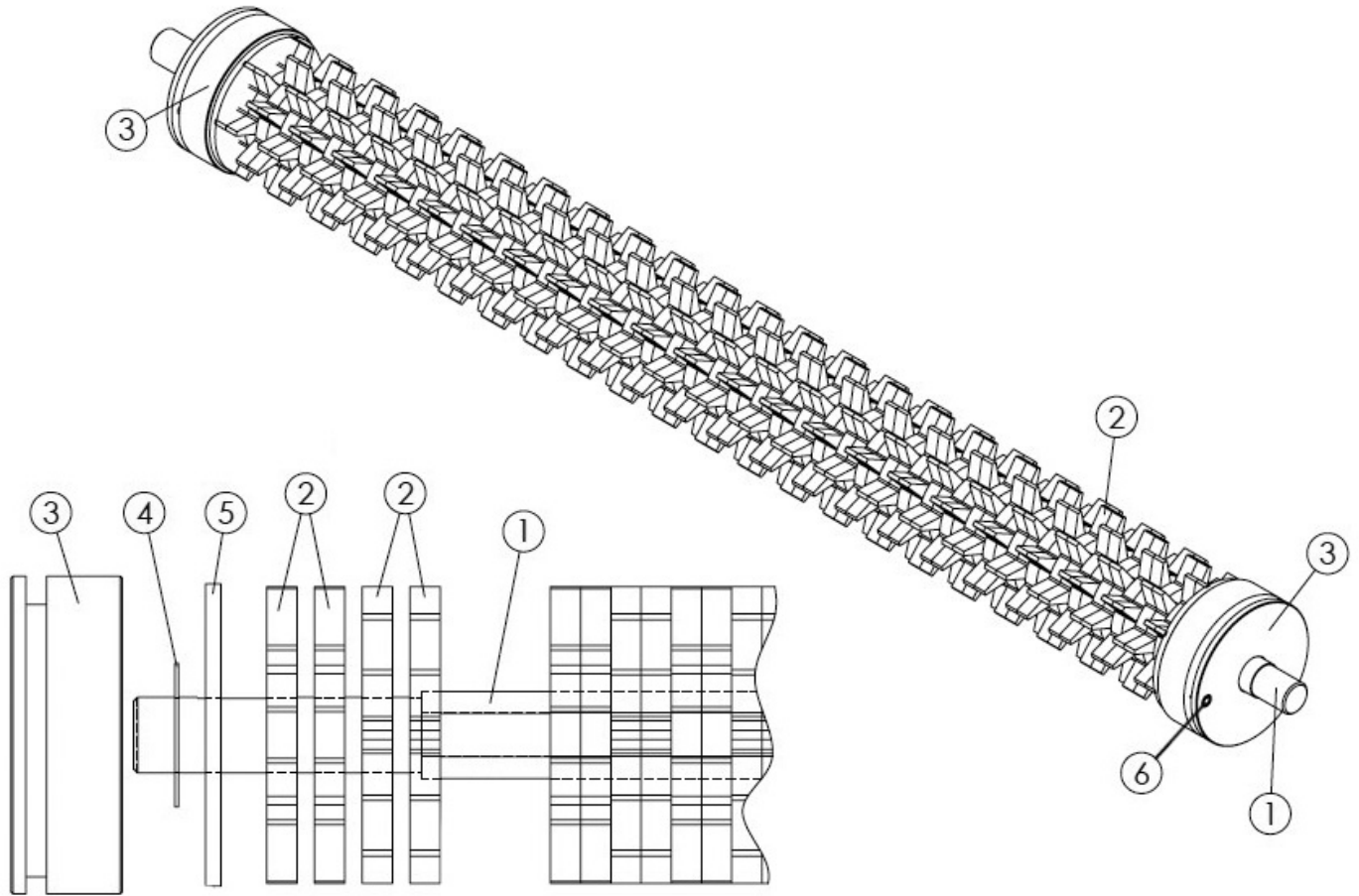

Micro Assembly-Meter Wheels

<u>ITEM</u>	<u>PART NO.</u>	<u>DESCRIPTION</u>	<u>QTY</u>
	312253	Wheel - Assembly Meter	
1	304130	Shaft - Meter Wheel	1
2	312252	Wheel - Meter Section 304	88
3	304125	Hub - Bearing	2
4	304133	Washer - .65id X 1.188od X .029 SS	2
5	96066	Washer - Rubber .625id	2
6	56313	Pin - Roll .188 X .75 SS	2

Micro Screens

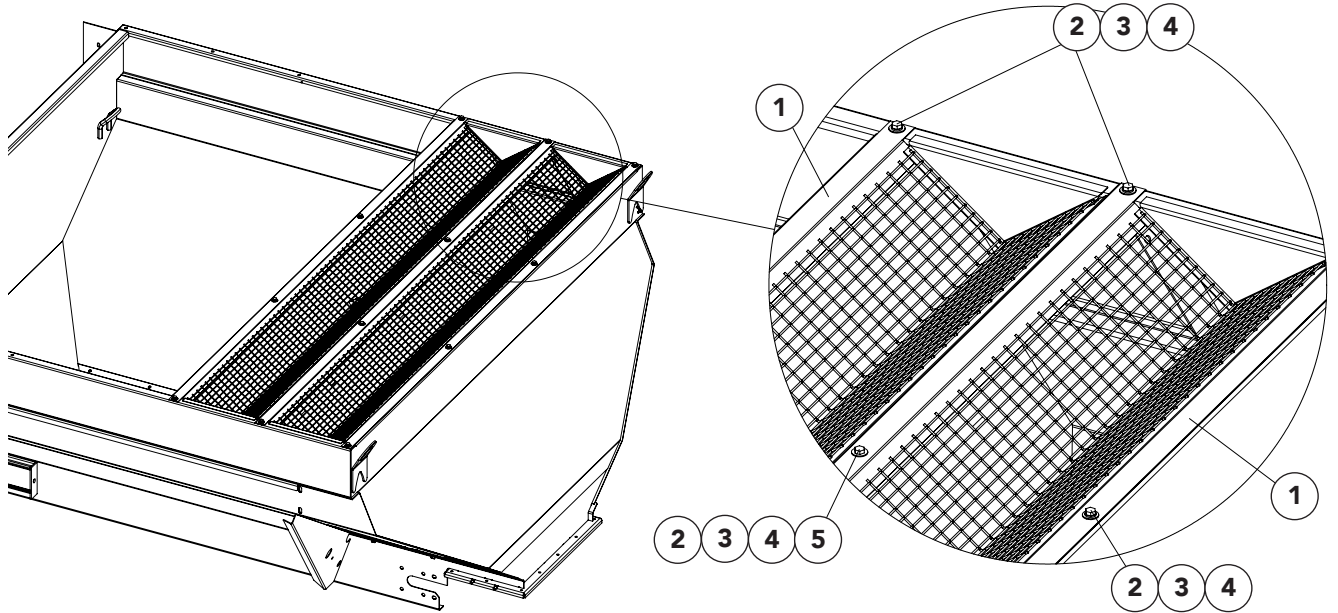

<u>ITEM</u>	<u>PART NO.</u>	<u>DESCRIPTION</u>	<u>QTY</u>
1	306931	Screen - Wldmt 304	AR
2	36293	Cap Screw - 3/8-16 x 3/4 SS	AR
3	36425	Washer - Flat 3/8 SS	AR
4	36420	Washer - Lock 3/8 SS	AR
5	72054	Nut - Lock 3/8 SS	2

Cover Group

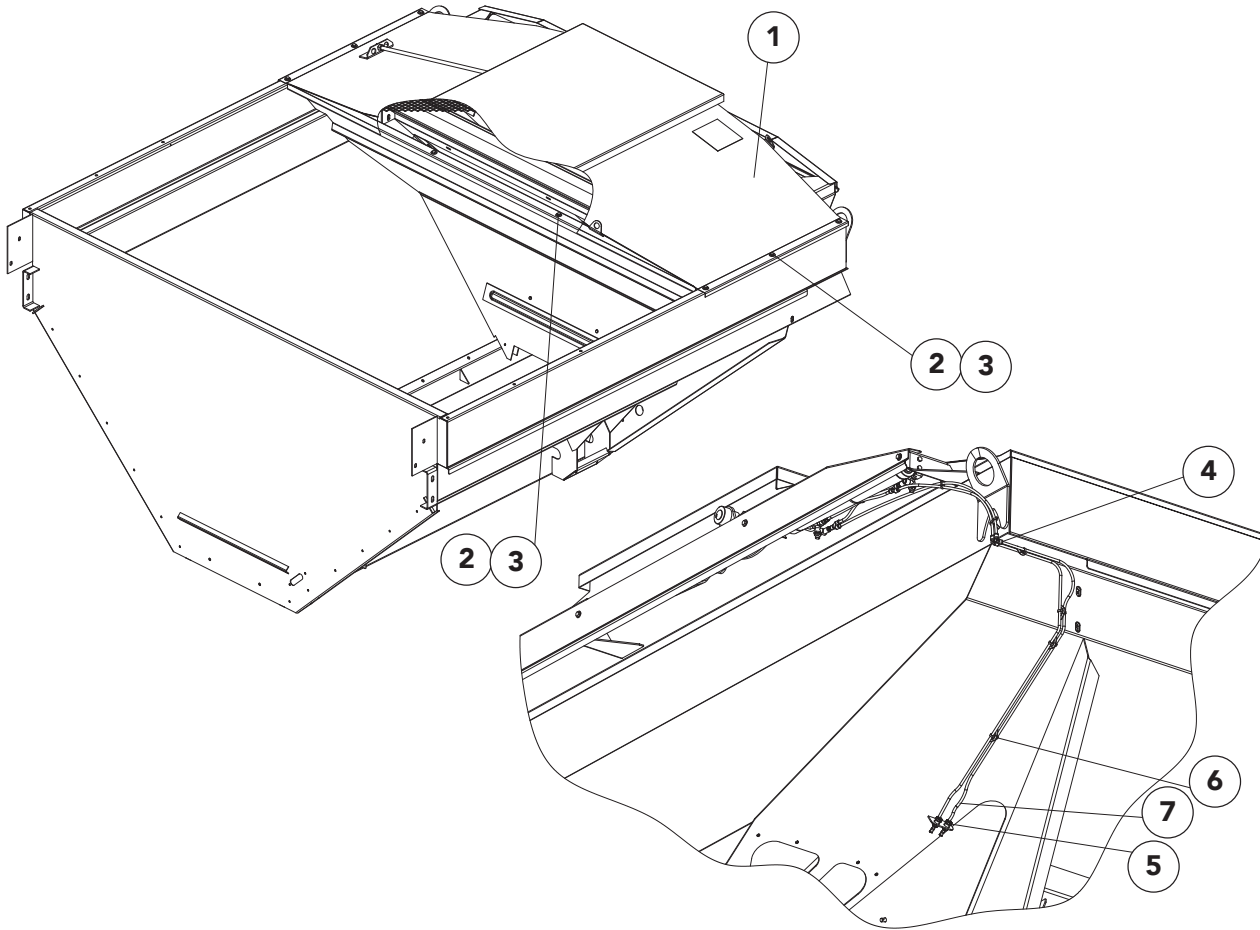

ITEM	PART NO.	DESCRIPTION	QTY
1	306629	Cover - Assembly MULTIBIN 304 (see next page)	1
2	36398	Cap Screw - 3/8 x 1 SS	10
3	36425	Washer - Flat 3/8 SS	10
4	306833	Fitting	2
5	306829	Fitting	2
6	99674	Wire - Tie	6
7	9005-0-7761	Tubing - 1/4 OD Airbrake Lock	11 ft.

Cover Assembly

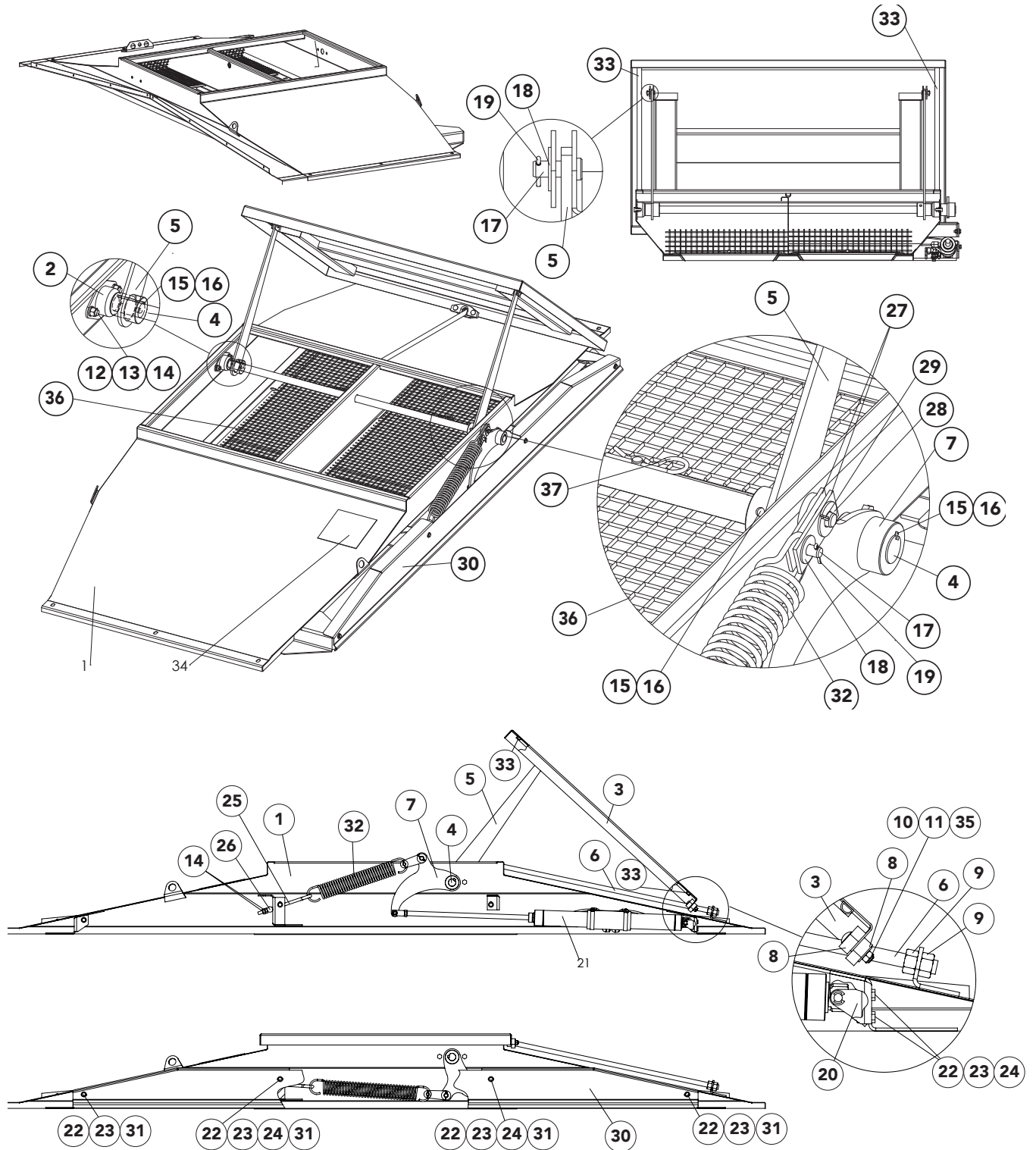

Cover Assembly

<u>ITEM</u>	<u>PART NO.</u>	<u>DESCRIPTION</u>	<u>QTY</u>
	306629	Cover - Assy	
1	306586	Cover - Wldmt	1
2	306711	Bearing - Flange 1"	2
3	306597	Lid - Wldmt 304	1
4	306710	Shaft - Pivot 304	1
5	306709	Link - Wldmt 304	2
6	306607	Rod - Guide 304	1
7	306697	Pivot - Wldmt 304	1
8	306809	Block - Guide	2
9	36417	Nut - Hex 5/8 SS	2
10	42221	Nut - Lock 5/16 SS	2
11	36424	Washer - Flat 5/16	2
12	36293	Cap Screw - 3/8 x 3/4 SS	4
13	36420	Washer - Lock 3/8 SS	4
14	36414	Nut - Hex 3/8 SS	4
15	2212	Key - Square 1/4 x 1-1/2	3
16	20742	Screw - Set 5/16 x 5/16	6
17	306816	Pin - Clevis	3
18	36425	Washer - Flat 3/8 SS	3
19	306817	Pin - Cotter	3
20	306811	Clevis - Base Cylinder SS	1
21	311034	Cylinder - Assy	1
22	36393	Cap Screw - 1/4 x 3/4 SS	6
23	36418	Washer - Lock 1/4 SS	6
24	36412	Nut - Hex 1/4 SS	4
25	306814	Eyebolt - Wire 3/8 x 6 SS	1
26	322864	Pivot - 304	1
27	311040	Plate - Clevis Spring 304	2
28	36426	Washer - Flat 1/2 SS	1
29	36427	Pin - Cotter 1/8 x 1	1
30	306806	Guard - Rear 304	1
31	72054	Nut - .375 -16NC SS LOCK	1

Cover Assembly

<u>ITEM</u>	<u>PART NO.</u>	<u>DESCRIPTION</u>	<u>QTY</u>
31	36423	Washer - Flat 1/4 SS	6
32	306813	Spring	1
33	306818	Seal - Rubber	12.25 ft.
34	55241	Decal - Danger Pinch Point	1
35	8804	Bolt - Carriage 5/16 x 1 SS	2
36	306870	Screen - Wldmt 304	2
37	36429	Pin - Hair	4
38	306927-AA	Transition Tarp LH 304	1
39	306927-AB	Transition - Tarp RH 304	1

Air Cylinder - Cover

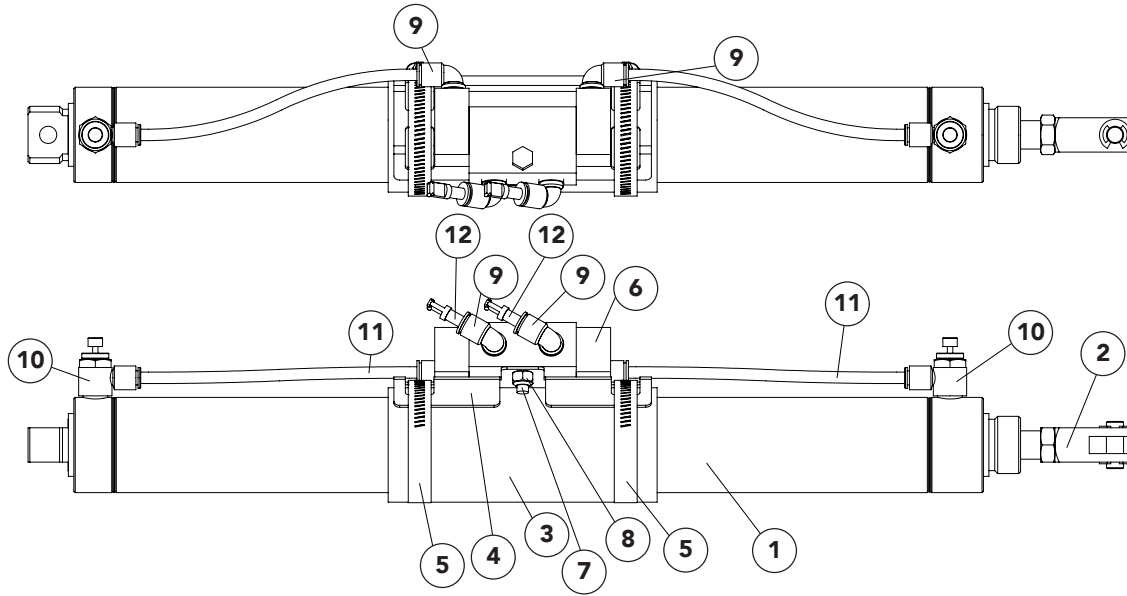

ITEM	PART NO.	DESCRIPTION	QTY
	311034	Cylinder Assy	
1	306810	Cylinder - Air 2 x 16 SS	1
2	306812	Clevis - Rod Cylinder SS	1
3	311038	Isolator - Tube	1
4	311037	Mount - Valve 304	1
5	308029	Clamp - Hose SAE 36 SS	2
6	311035	Valve - Dual Pilot Check	1
7	41669	Capscrew - .25-20NC X 1.75 SS	1
8	42034	Nut - Lock 1/4-20NC SS	1
9	308222	Fitting - 4-4 630202K	4
10	311036	Valve - Speed Control	2
11	9005-0-7761	Tubing -1/4 OD Airbrake Black	1.33 ft.
12	306828	Fitting - 4 630101K	2

Tarp Transition

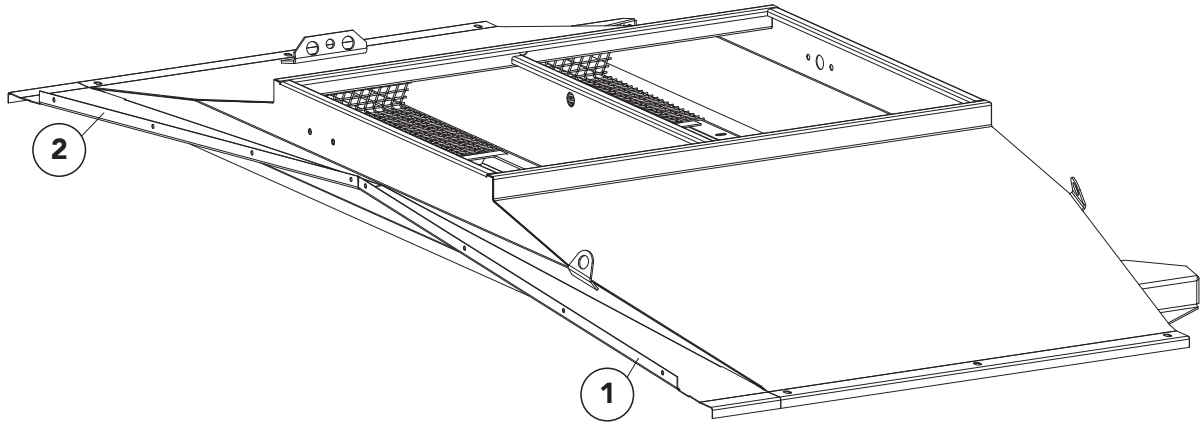

<u>ITEM</u>	<u>PART NO.</u>	<u>DESCRIPTION</u>	<u>QTY</u>
1	306927-AA	Transition - Tarp LH 304	1
2	306927-AB	Transition - Tarp RH 304	1

Lid Pneumatics

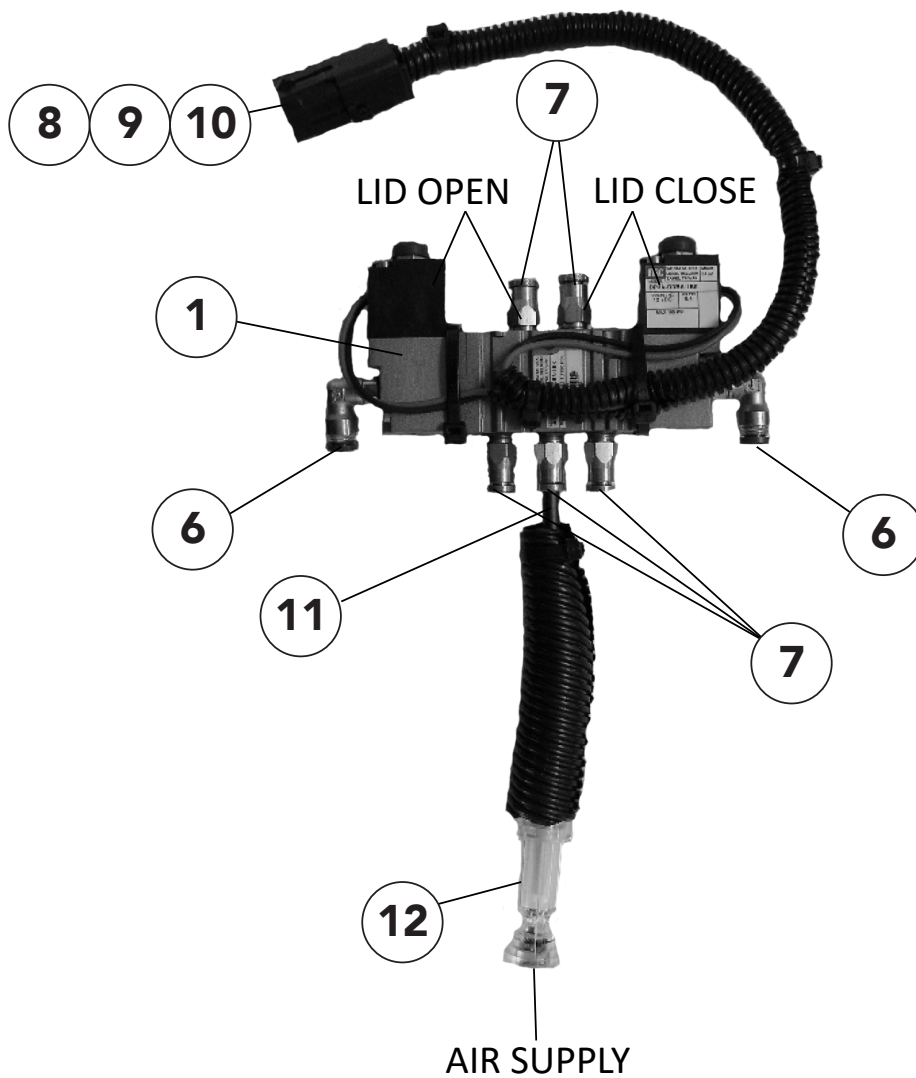
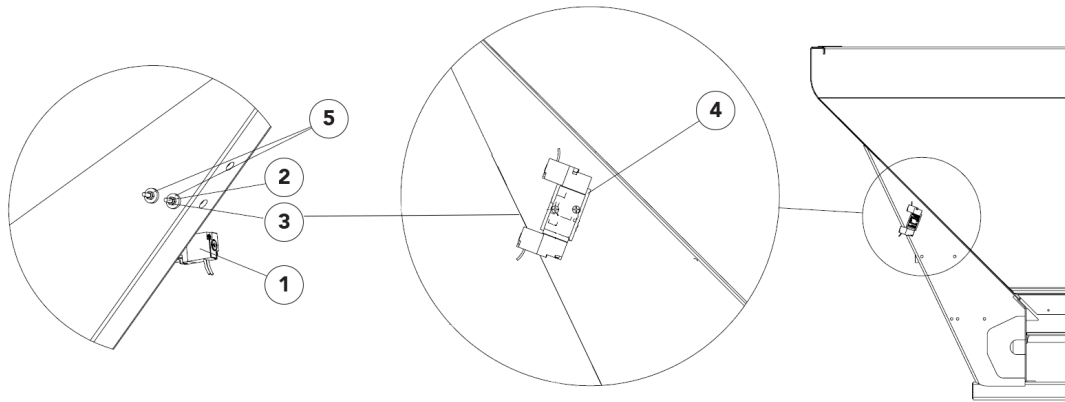

Lid Pneumatics

<u>ITEM</u>	<u>PART NO.</u>	<u>DESCRIPTION</u>	<u>QTY</u>
	307186	Valve - Assy, Includes Items 1, 6 - 14	1
1	307185	Valve - Assy, Includes Items 8 - 11	1
2	307598	Screw - Truss Head #8-32NC x 2 SS	2
3	45168	Nut - Lock #9-32NC	2
4	307596	Spacer - Air Valve Mntg	1
5	307597	Washer - Step	2
6	307187	Fitting - 4-0 630220B	2
7	9005-0-7833	Fitting - 4-2 630102B	5
8	58728	Conduit - Flexible	.375'
9	303730-BD	Connector - Male Sealed	1
10	303730-EC	Seal - Cable	4
11	303730-DC	Terminal - Male Sealed	4
12	9005-0-7761	Tubing - Air Brake	38'
13	308219	Conduit - Flexible	.33'
14	311039	Filter - In-Line	1

Decals

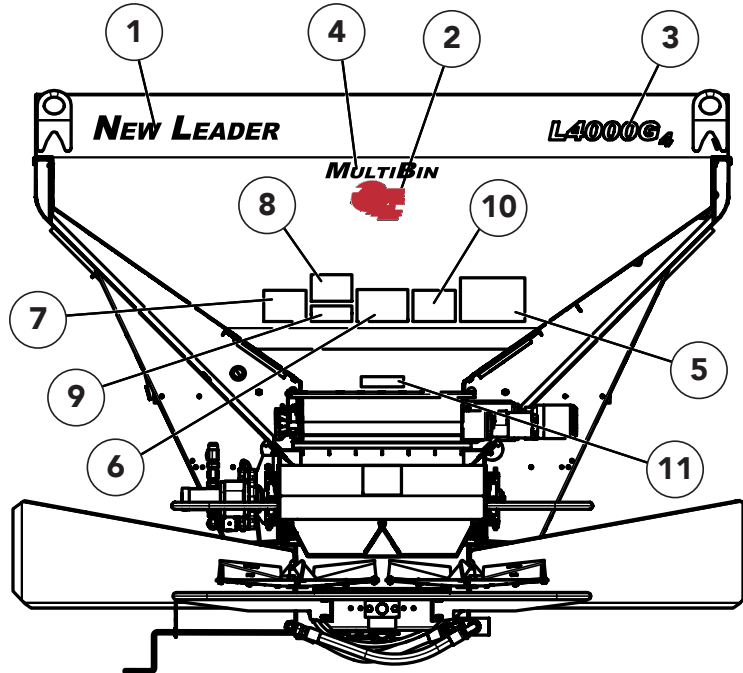

ITEM	PART NO.	DESCRIPTION	QTY
1	312561	Decal - New Leader Black	1
2	87122	Decal - G4	1
3	306151	Decal - L4000G4	1
4	312971	Decal - MULTIBIN	1
5	368	Decal - Danger Flying Material	1
6	71526	Decal - Important Spread Pattern	1
7	21476	Decal - Important Chain Life	1
8	55631	Decal - Warning Moving Part Hazard	1
9	304206	Decal - Notice Do Not Spread Herbicide	1
10	321	Decal - Caution Hazardous Materials	1
11	39017	Decal - No Step	1