



G5

**NL5000 G5**  
WALK-AROUND GUIDE

# TABLE OF CONTENTS

- OVERVIEW..... 3
- SPECIFICATIONS..... 4
- CHAIN OILER AND LUBRICATION ..... 10
- HYDRAULIC RESERVOIR & COOLER ..... 11
- HYDRAULIC MANIFOLDS ..... 12
- PWM VALVES AND SPINNER CONTROL ..... 13
- CHAIN TENSIONER ..... 14
- G5 SWATH WIDTH CONTROL ..... 15
- NL5000 G5 ELECTRONICS ..... 16
- NEW LEADER USER INTERFACE..... 17
- MULTAPPLIER & MULTIBIN ..... 18
- VALUE STATEMENTS ..... 19

# Building The Best Since 1939.

New Leader Manufacturing is family owned and operated. Our business is built on honesty and integrity.

We have a passion for what we do, and we believe that we can make a better tomorrow by building the best today.

The leading brand of dry spinner spreader crop nutrient applicators, New Leader equipment is used to spread fertilizer, lime, compost, and litter. We partner with leading manufacturers such as AGCO, CNH, John Deere, RBR, and more.



# NL5000 G5

The NL5000 G5 sets itself apart by allowing operators to apply fertilizer with pinpoint accuracy.

By using the G5 spinner technology and leveraging the conveyor speed adjustments, operators can reduce overlap, decrease nutrient waste, and ensure nutrients are placed only where they need them, not where they don't.



# LET'S TALK SPECS

The **NL5000 G5** is a hopper-type spreader intended for spreading free flowing granular agricultural materials, such as dry fertilizers, agricultural limestone, gypsum, seeds, and cover crops. It is intended for agricultural vehicle mounting.

The unit is powered hydraulically and provides independent variable speed control for the spinner and full automatic ground speed control for the conveyor.

The conveyor delivers material to the spinners through a hydraulically adjustable metering gate at the rear of the hopper body. Orbital-type hydraulic motors mounted to 6-to-1 ratio spur gear case drive the conveyor. The conveyor is a belt-over-chain type, having parallel strands of pintle-type (#4) chain joined by cross bars every other link.

The spinner assembly has two 24-inch (610 mm) diameter dished discs. Each disc has four formed and heat treated fins that are adjustable to radial angle. The spinner assembly is fully adjustable by means of a hydraulic cylinder.

The optional 304 stainless steel hopper-style spreader MultApplier or MultiBin may be inserted in the main bin.

## NL500 G5

Length	in (cm)
12' (3.66m)	188 (478)
14' (4.27m)	200 (508)

Struck Capacity	Cu Ft (Cu M)
12' (3.96m)	253 (7.16)
14' (4.27m)	298 (8.44)

Estimated Weight	Lbs (kg)
12' (3.96m)	4200 (1905)
14' (4.27m)	5100 (2313)

## MultiBin - Sideboard Included

12' Unit - Bin 1 Length w/ MultiBin (B)	57 in (145 cm)
14' Unit - Bin 1 Length w/ MultiBin (B)	84 in (213 cm)

<b>Estimated Ship Weight</b>	<b>1800 (816 kg)</b>
------------------------------	----------------------

# SPECIFICATIONS

# NL5000

MultApplier	5ft MultApplier	7ft MultApplier
Est. Ship Weight	1200 (544kg)	1400 (635kg)
	Capacities with 5 ft. MultApplier Cu ft (Cu M)    Capacities with 7 ft. MultApplier Cu ft (Cu M)	
Insert Capacity	115 (3.25)	161 (4.60)
12' (3.96m) Bin 1 Total Struck Capacity	195 (5.52)	166 (4.70)
12' (3.96m) Bin Total Struck Capacity	310 (8.77)	327 (9.26)
14' (4.27m) Bin 1 Total Struck Capacity	253 (7.16)	195 (5.52)
14' (4.27m) Bin 1 Total Struck Capacity	368 (10.42)	356 (10.08)

MultiBin - Sideboard Included	
Struck Capacity	Cu Ft (Cu M)
12' NL5000 w/ MultiBin - Bin 1	137 (3.80)
14' NL5000 w/ MultiBin - Bin 1	195 (5.52)
MultiBin - Bin 2	139 (3.94)
MultiBin - Bin 3	23 (.65)
MultiBin - Bin 4	21 (.59)

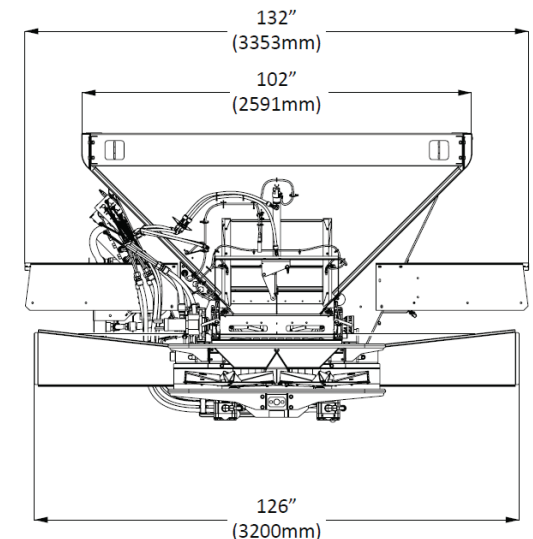
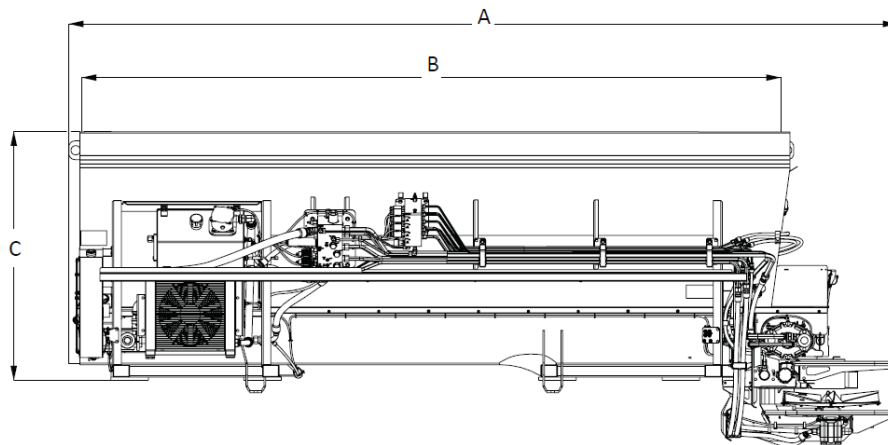

SPECIFICATIONS

# NL5000

Front View

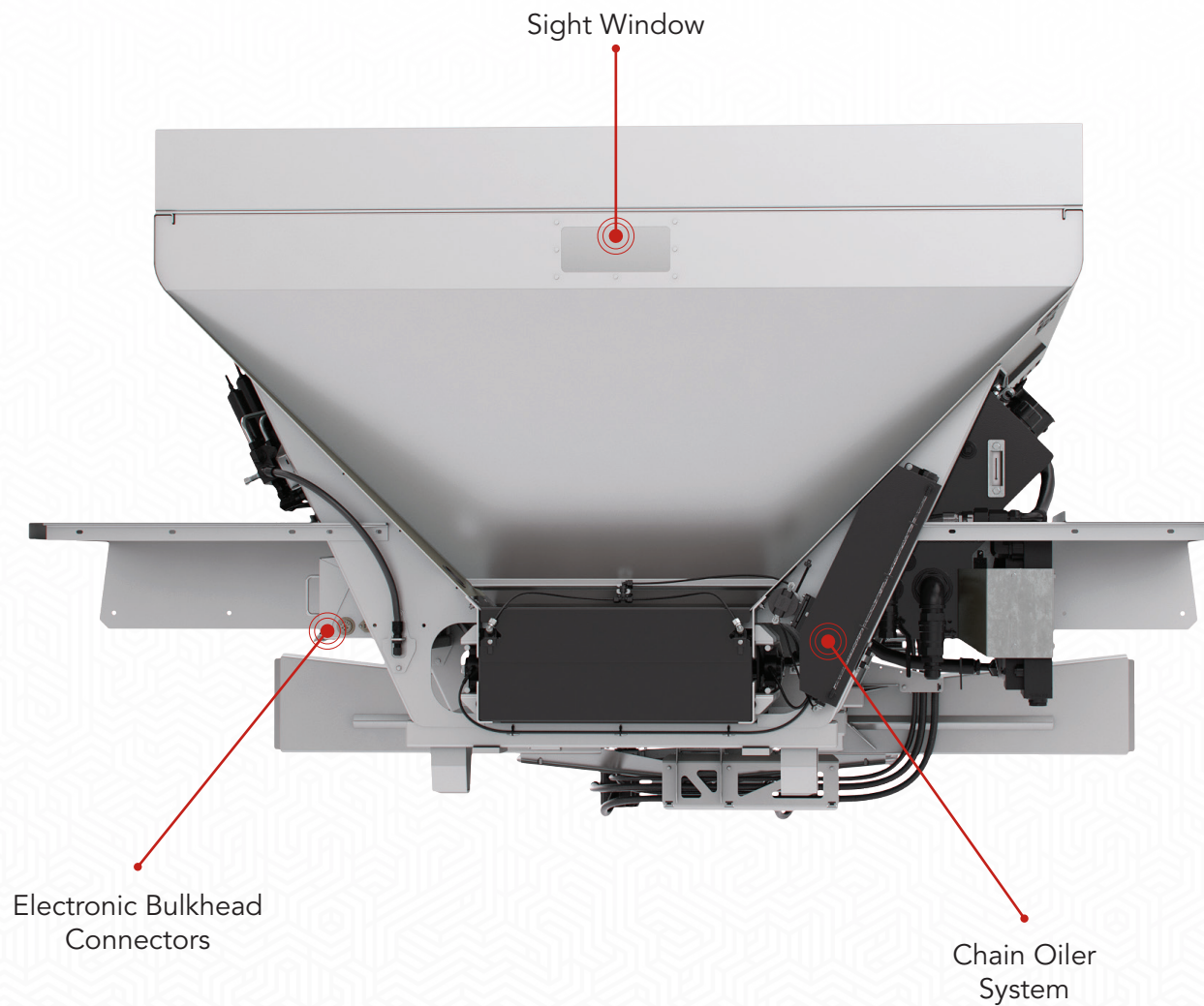

SPECIFICATIONS  
**NL5000**

Left-Hand  
Side View

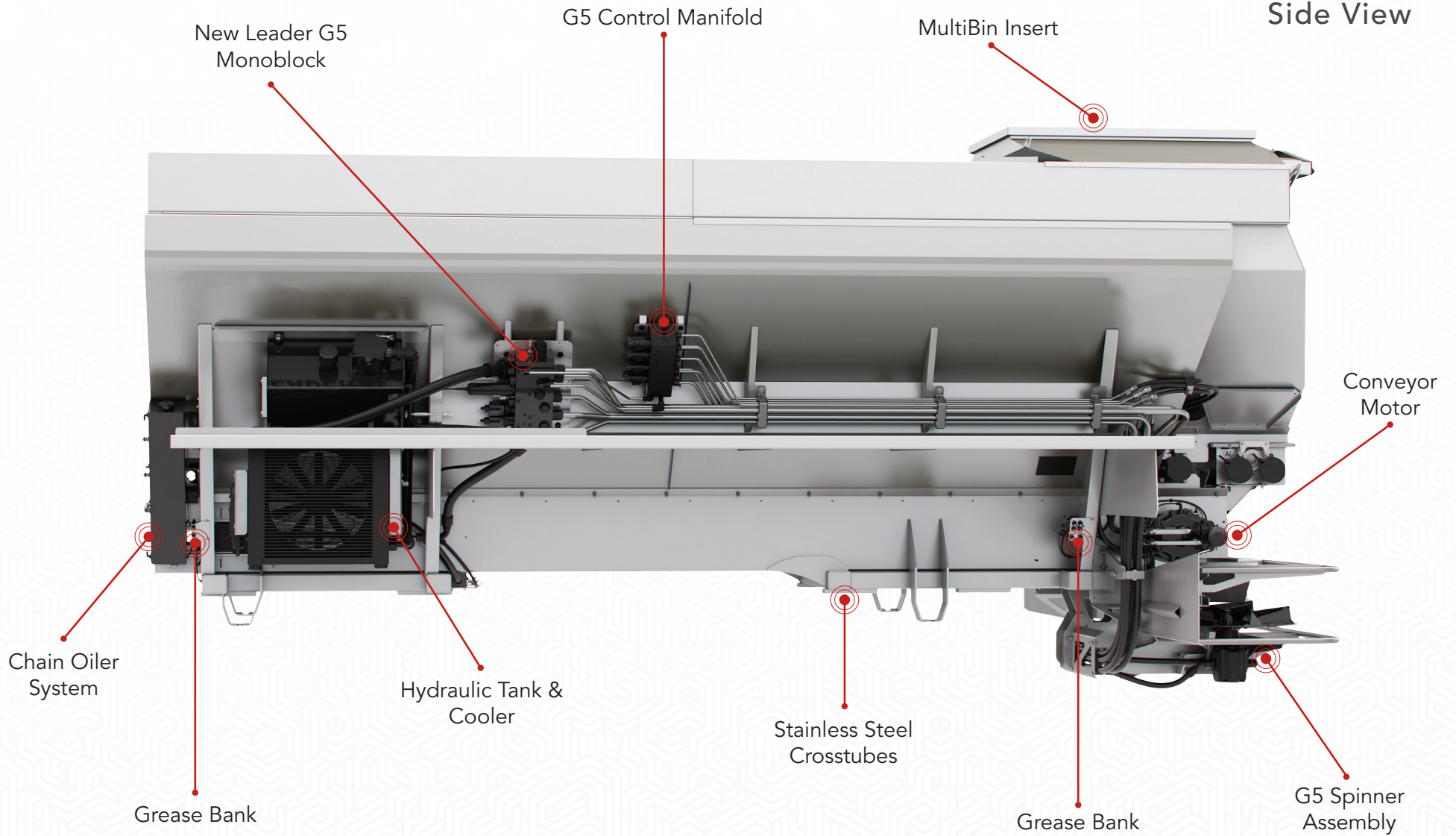

# NL5000

## Rear View

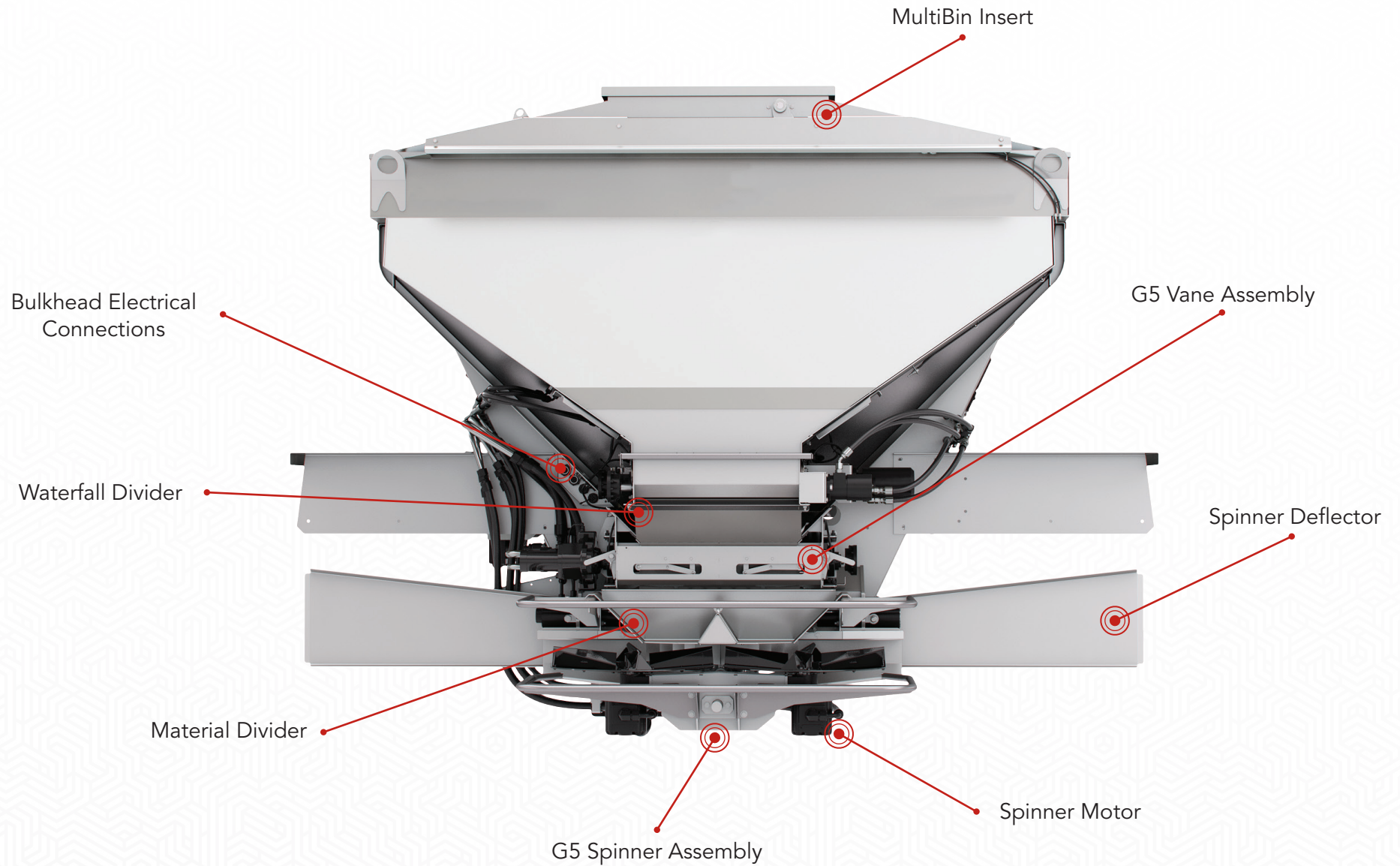

SPECIFICATIONS  
**NL5000**

Right-Hand  
Side View

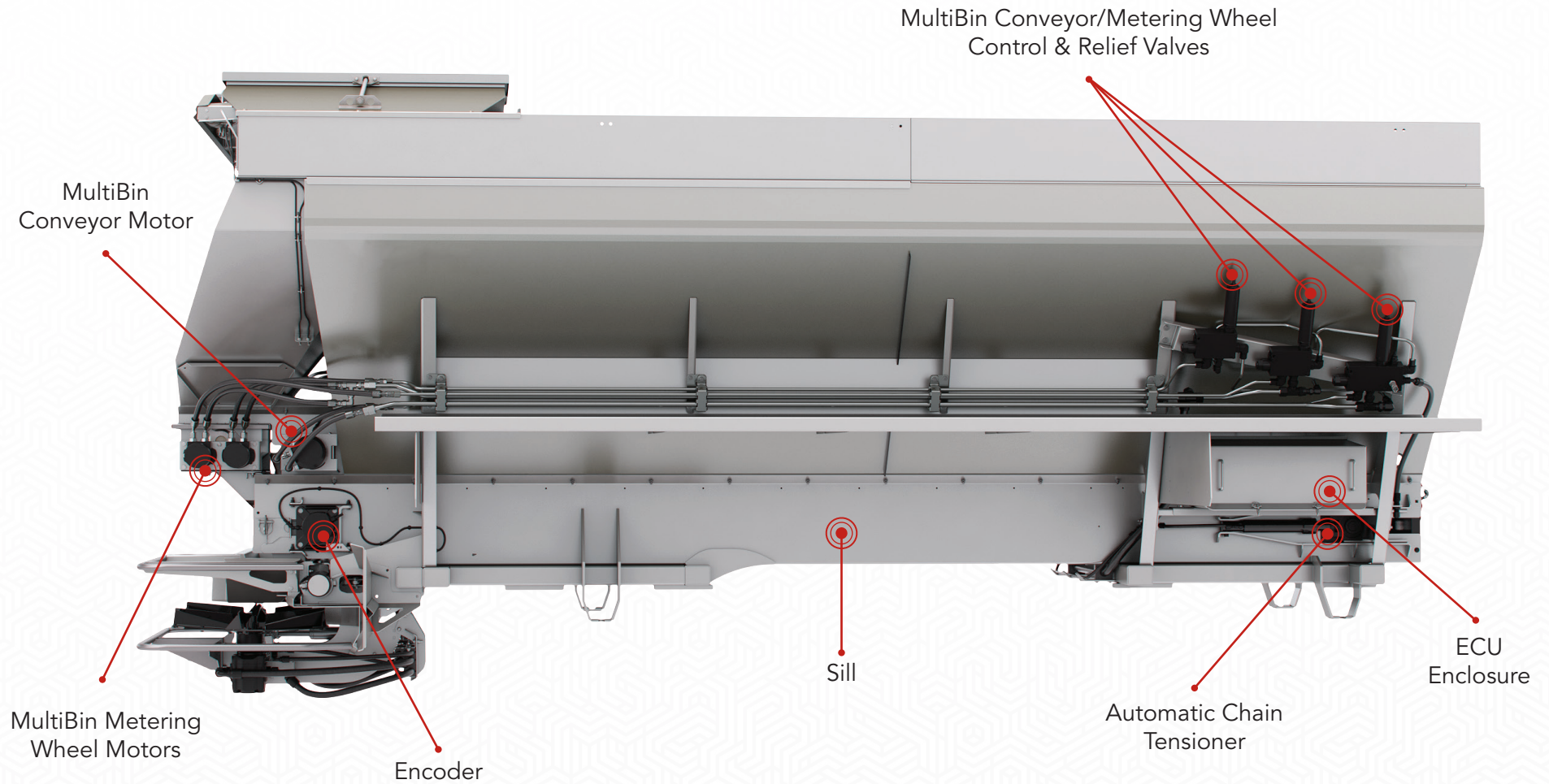

## CHAIN OILER AND LUBRICATION

The pressurized chain oiler is for performing lubrication service of the belt-over-chain conveyor. This system is operated through the controller and accessed through the display. By setting oiling reminders, the operator is notified when the set time limit is reached and the chain needs to be lubricated. This reduces wear of the chain and deterioration from rust. Utilize a mixture of 75% diesel fuel and 25% clean oil.

### KEY POINTS

- In-cab and automated conveyor chain oiler controls and simplifies daily maintenance
- Extends chain life on one of the most expensive consumable components
- Centralized lubrication points for easy and quick maintenance

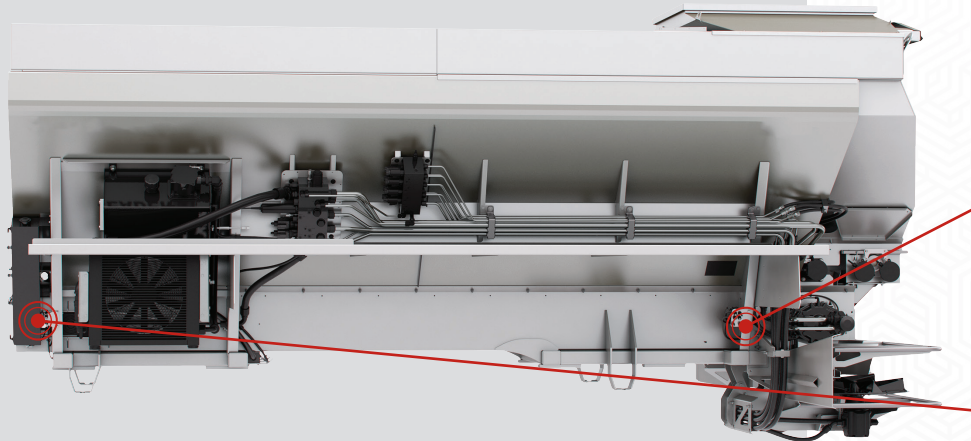

## HYDRAULIC RESERVOIR & COOLER

The hydraulic reservoir and cooler ensures that proper fluid conditions are met. With higher output capabilities, the duty cycles are much greater. With a thermostatically-controlled cooler, the system will maintain a set working temperature, providing a more efficient working system and extended hydraulic component life.

With low fluid, filter, and temperature sensors, monitoring the NL5000 G5 system is simple. All readings are able to be displayed on the monitor, and warnings let the operator know when the system is not performing properly.

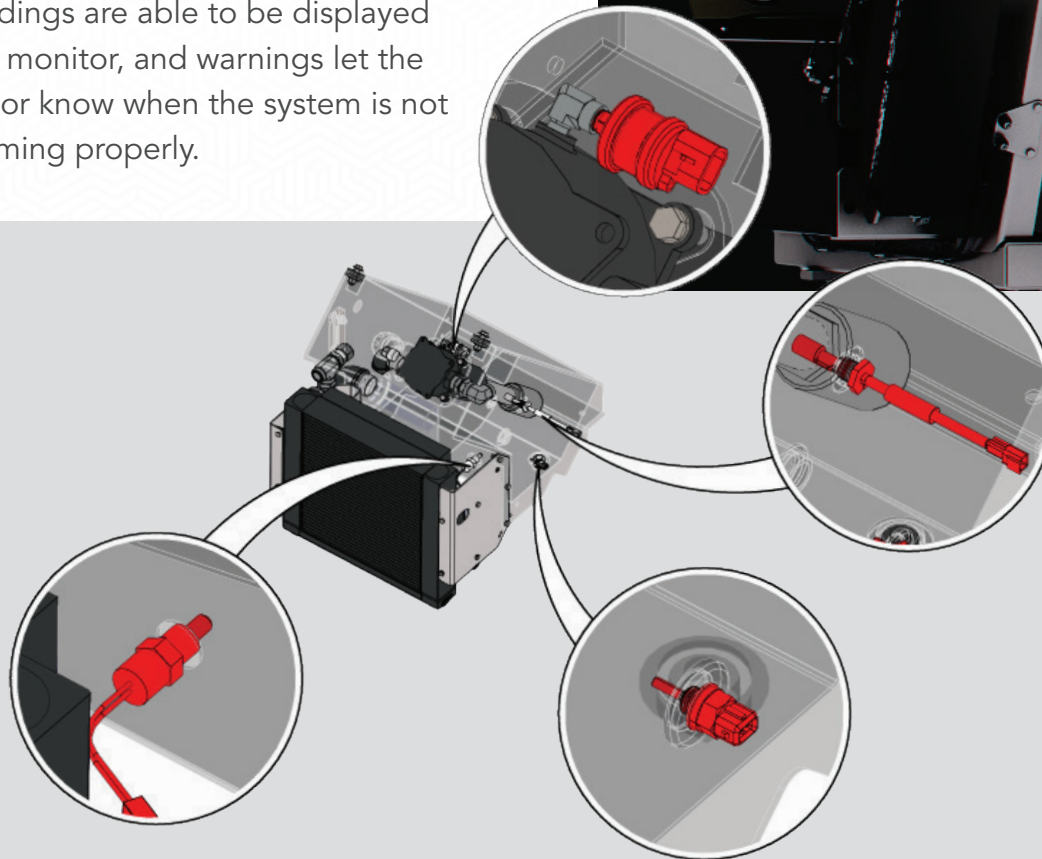
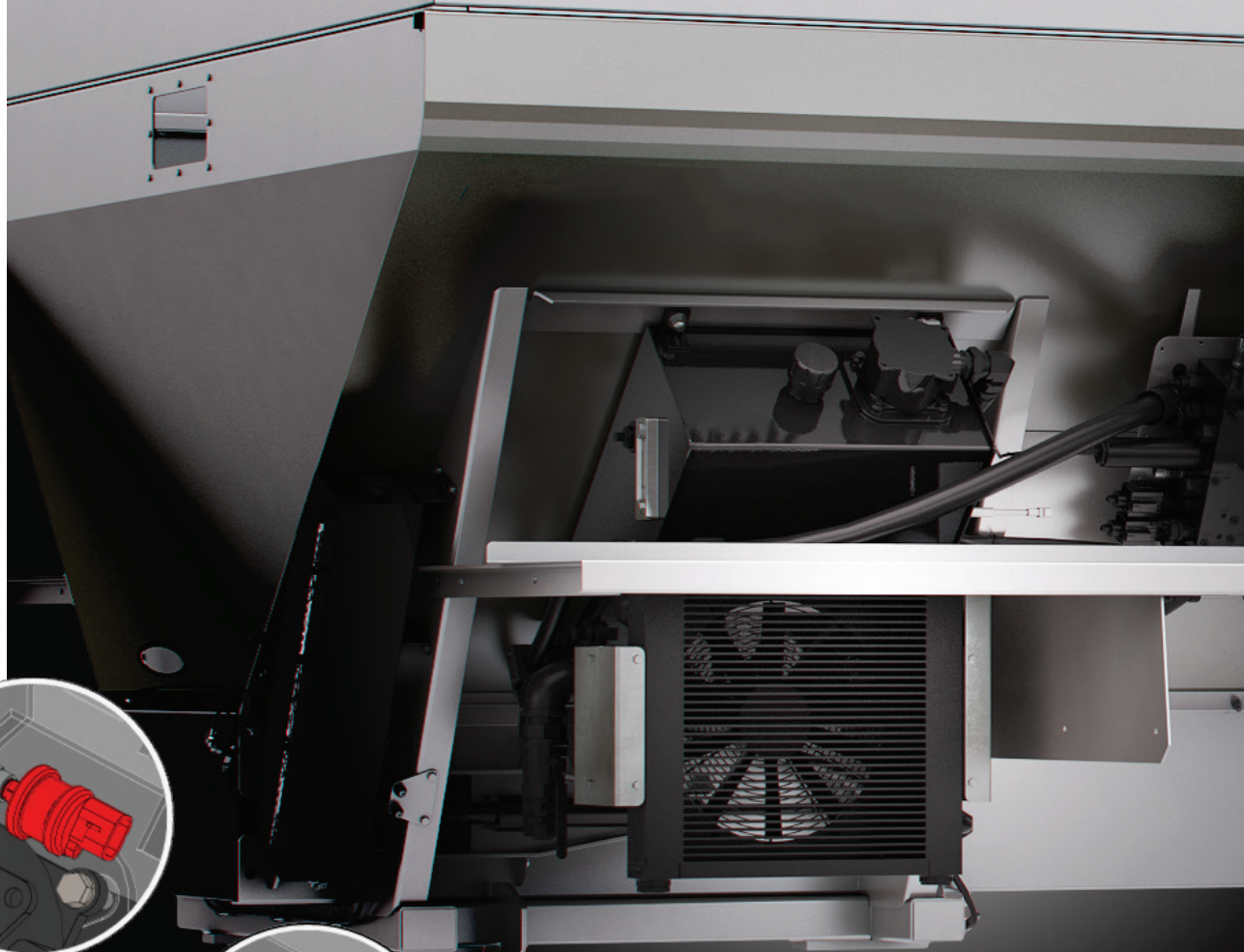

### KEY POINTS

- Thermostatically-controlled cooler maintains proper working temperatures, improving efficiencies
- Temperature, filter, and low fluid sensors

## HYDRAULIC MANIFOLDS

All of the main hydraulic functions are tied into two monoblock hydraulic manifolds. The New Leader G5 Monoblock (1) controls the main conveyor, the spinners, and automatic chain tensioning. The G5 Control Manifold (2) controls all of the automated fan frame movements, fore/aft and left/right, and feedgate controls.

### KEY POINTS

- Improved efficiencies and control via common manifold
- Hydraulic test ports
- Anti-cavitation valves that smooth spinner shutdown
- Automatic chain tensioner
- Automated spinner control with G5 Control Manifold

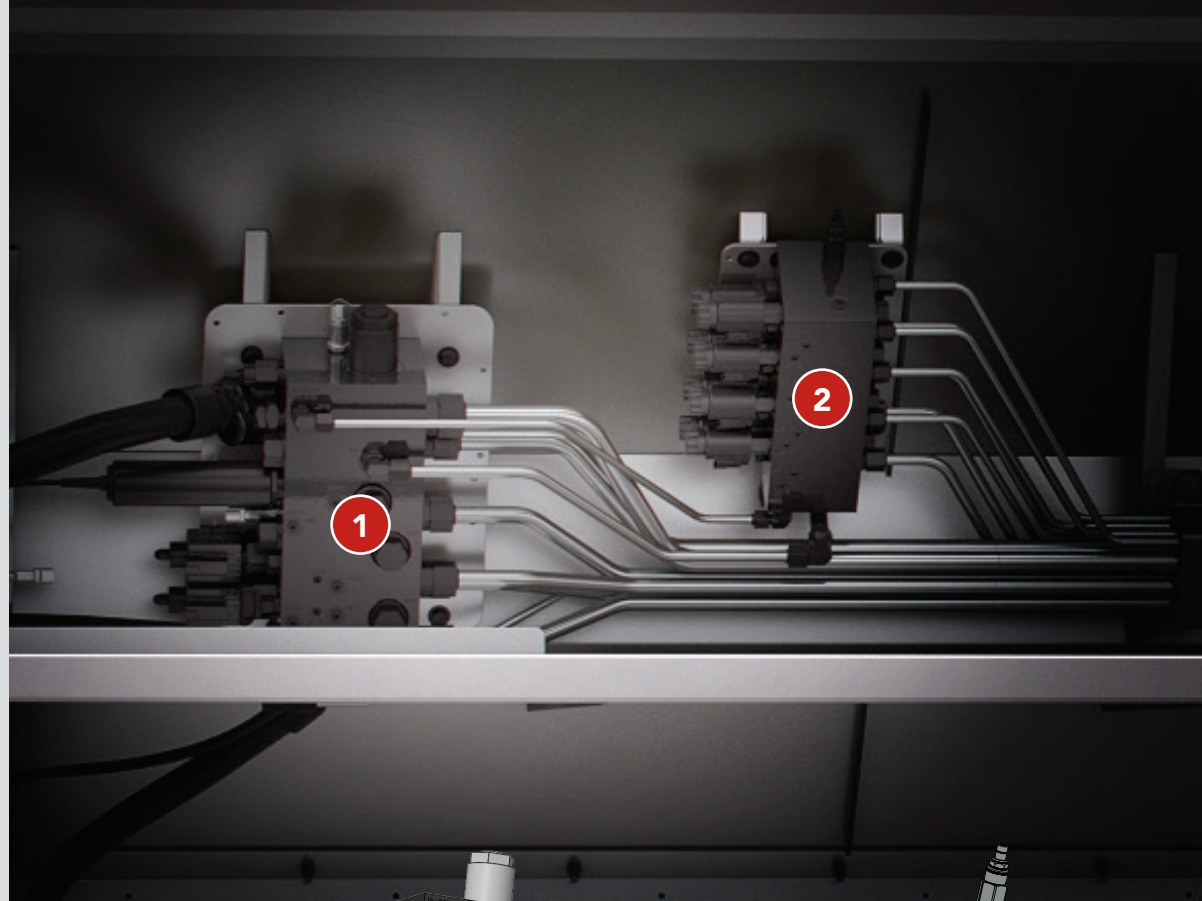

New Leader G5  
Monoblock

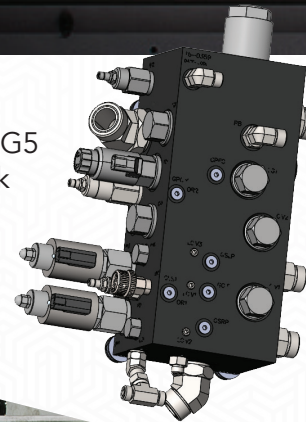

G5 Control  
Manifold

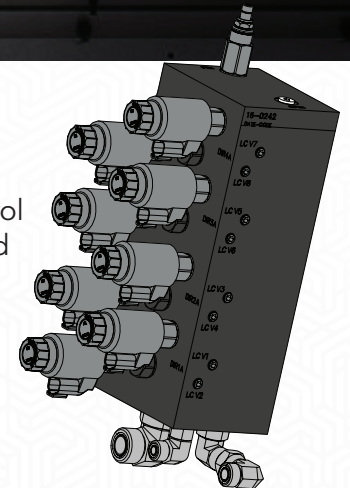

## PWM VALVES AND SPINNER CONTROL

The PWM valves for each spinner are integrated into the New Leader G5 Monoblock. The electronic PWM hydraulic valve is automatically adjusted by the controller to maintain the target spinner speed programmed from the controller. This ensures a consistent and uniform spread pattern at all times.

The PWM Valve for the main conveyor control is integrated into the New Leader G5 Monoblock. The PWM valve has a fast reaction time to meet high demands when operators are traveling at higher application speed.

### KEY POINTS

- Integrated into New Leader Monoblock
- Maintains constant spinner speeds for consistent spread width
- Closed-loop system that adjusts for oil temperature, viscosity, and pressure
- Fast reaction PWM Conveyor Valve for high speed applications and quick rate changes

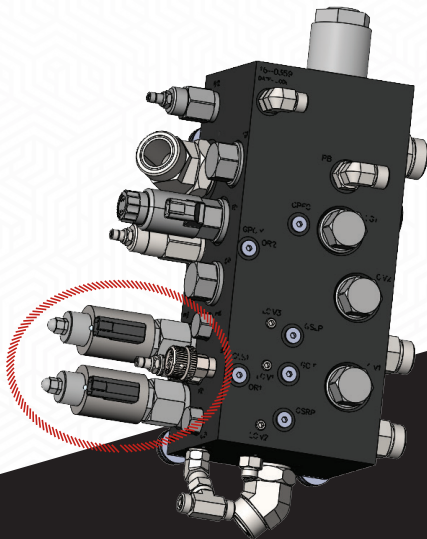

**New Leader PWM Valves**  
integrated in New Leader  
G5 Monoblock



## CHAIN TENSIONER

The automatic chain tensioning feature maintains proper conveyor tension and reduces maintenance requirements. When the pump is engaged, both tensioning cylinders are actuated or pressurized. During extended periods of non-use, the cylinders will relax.

A chain tension sight window is located near the rear of the spreader. When the conveyor is running, the top edge of the chain should be visible between the MIN and MAX lines in the window.

### KEY POINTS

- Maintains proper conveyor tension at all times during operation
- Reduces maintenance requirements
- 304 stainless steel front idler tensioning brackets

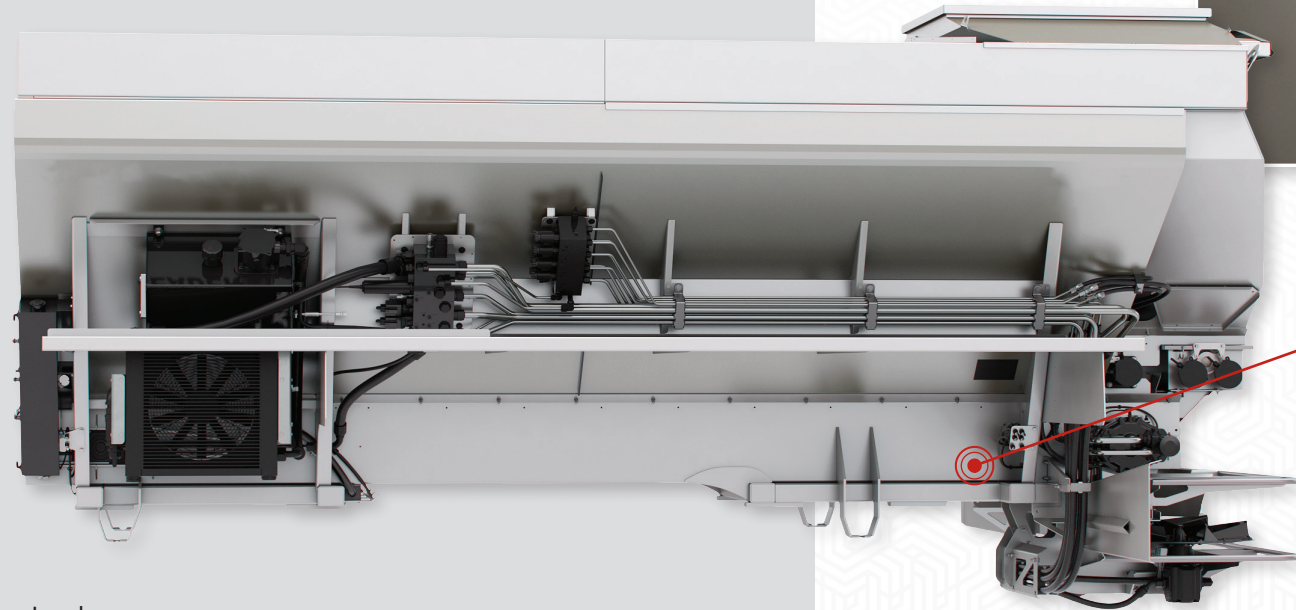
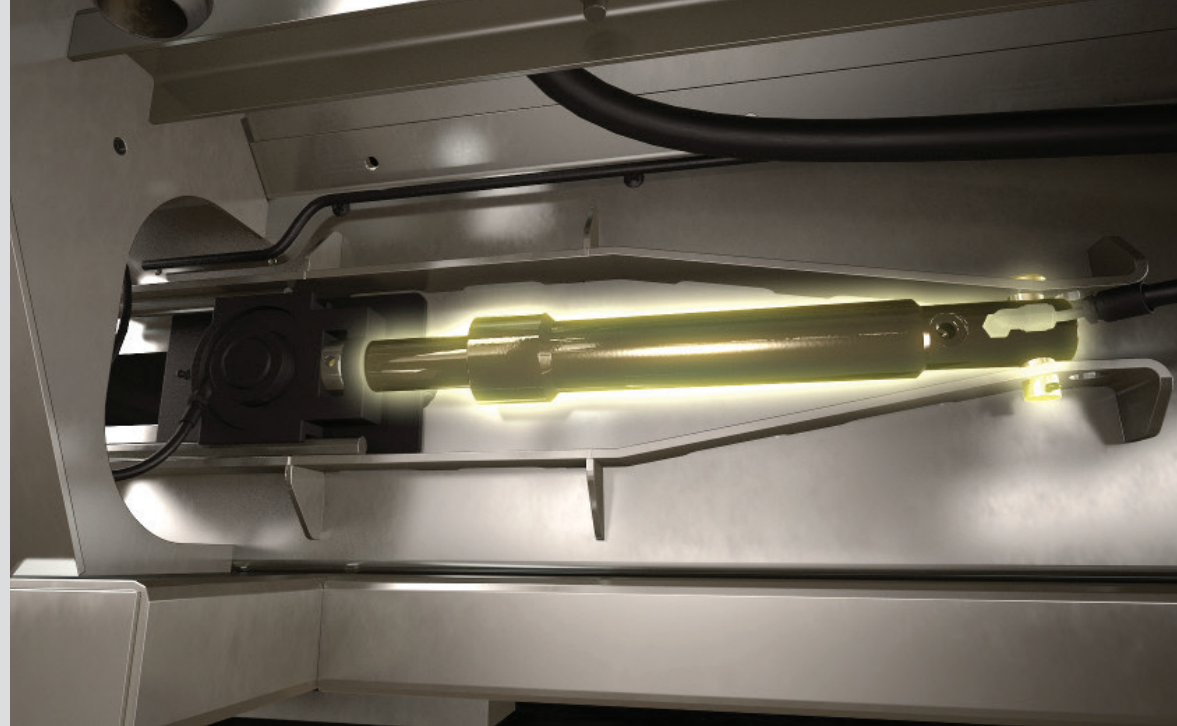

Chain Tension Sight Window

## G5 SWATH WIDTH CONTROL

The NL5000 G5, with its patented 16-section swath width control technology, lets operators apply nutrients with pinpoint accuracy. By shifting the spinner assembly fore/aft and left/right, and leveraging the conveyor speed adjustments, operators can alter where the product is broadcast in the field. This innovative patented technology reduces overlap, decreases nutrient waste, and ensures nutrients are placed only where they're needed.

### KEY POINTS

- 16-section swath width control
- Fore/aft and left/right automated spinner assembly control
- 1/2 width spreading
- Last Pass Control
- Boundary spreading



Last Pass Control

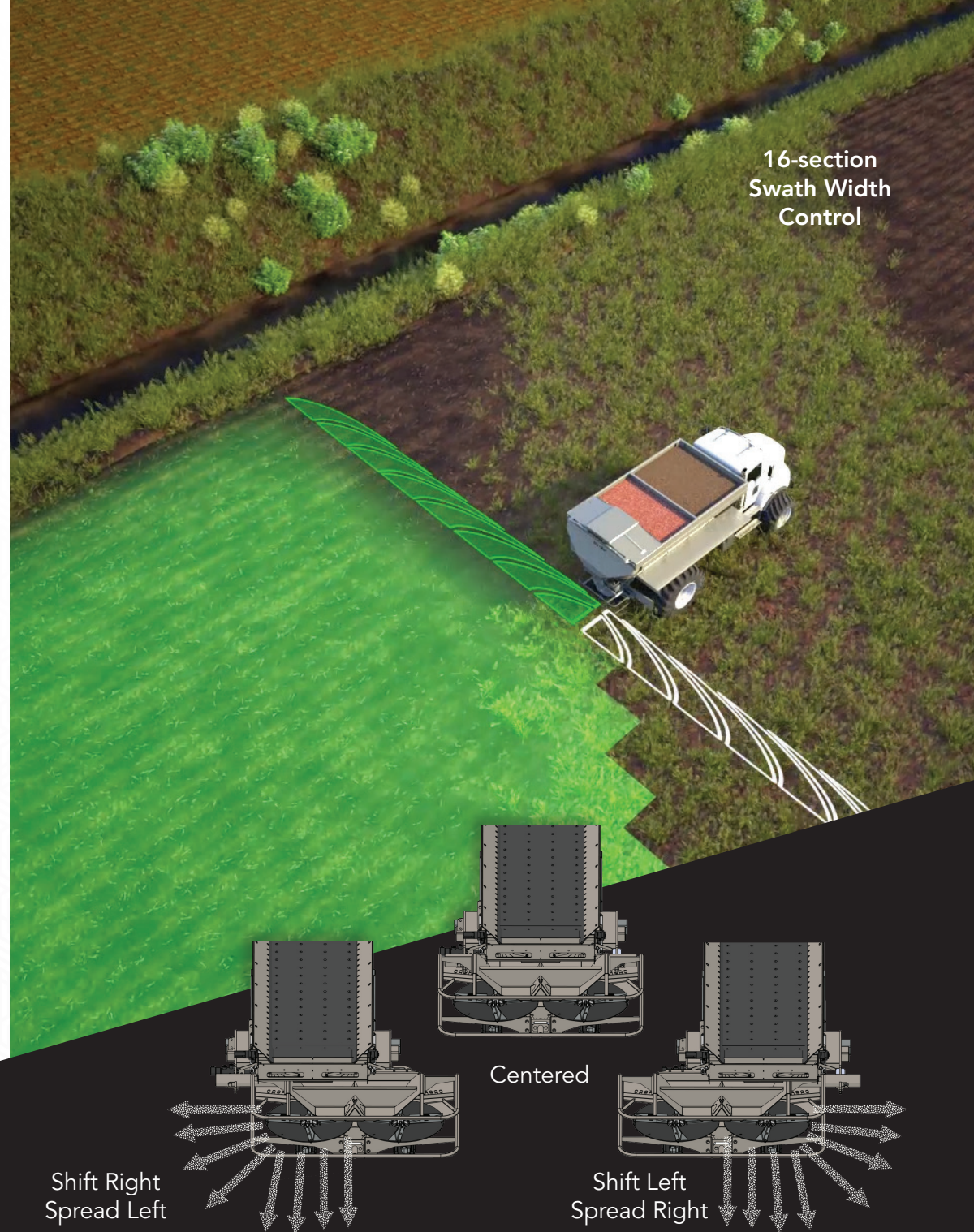

16-section  
Swath Width  
Control

Shift Right  
Spread Left

Centered

Shift Left  
Spread Right

## NL5000 G5 ELECTRONICS

New Leader partnered with Ag Leader to develop a complete electronic control system and user interface.

The ISO-Ready system utilizes a CAN system with specialized modules to offer complete system control.

### KEY POINTS

- Complete electronic package
- Co-developed with Ag Leader, an industry leader in precision agriculture technology
- Factory installed and tested
- Diagnostic feedback
- Stainless steel component enclosure
- 2-year warranty for electronics and complete unit

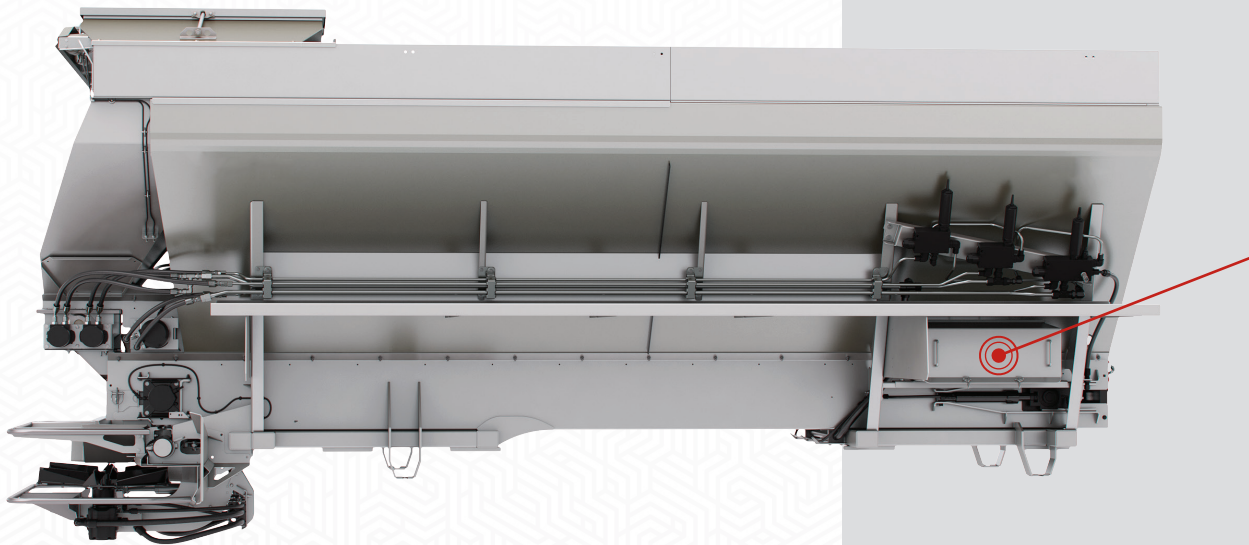
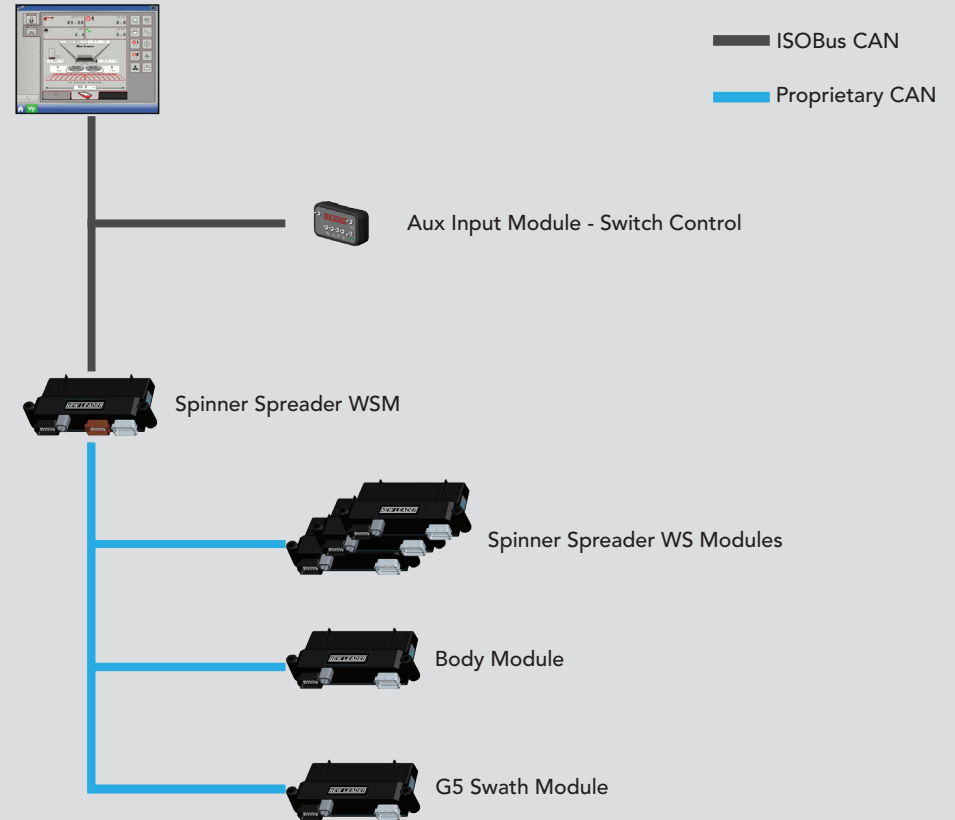

## NEW LEADER USER INTERFACE

The NL5000 G5 runs completely off New Leader software that is truly plug-and-play with an ISOBUS-ready display. Equipped with hardware to meet ISOBUS (11783) Platform, the New Leader User Interface is all about simplicity; simplicity for our OEM partners, simplicity for our dealers, and simplicity for our customers.

The New Leader User Interface allows us to add fully-tested improvements, and provide the best solution to meet our customers' needs while also providing complete support.

The New Leader User Interface allows customers to use any ISOBUS-ready display in the cab, and allows for complete machine control and monitoring in one simple, easy-to-use package from the factory.

### KEY POINTS

- Easy-to-use interface
- Up to 25 stored product profiles and patterns
- ISOBUS-ready
- Diagnostic feedback
- Automated service notifications
- Low bin countdown
- Feed gate optimizer



## MULTAPPLIER & MULTIBIN

Reduce man hours, field compaction, and fuel consumption by applying two products in a single pass with the **MultApplier**, available in 5-ft or 7-ft sizes.

The MultApplier allows for two materials to be spread simultaneously. It features a 24-inch (60.96 cm) 409 stainless steel belt-over-chain type conveyor having parallel strands of 409 stainless steel pintle-type (#4) chain joined by cross bars every other link. The direct driven conveyor is also controlled independently enabling the delivery of material at variable rates through the adjustable gate at the rear of the hopper body. It also utilizes a hydraulically adjustable metering gate. The waterfall divider improves material placement on the spinner for a more effective spread pattern.

The **MultiBin** will transform a single-bin spreader to a 3- or 4-hopper unit, which can be used independently or together for straight and variable rate applications. The front two hoppers dispense fertilizer products while

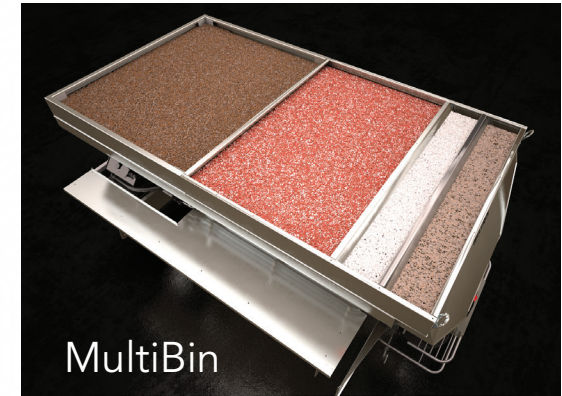

the single or dual hopper at the rear dispense(s) micronutrients or seeding products. The rear bin(s) are sloped forward to improve chassis weight distribution. Material is delivered from the front bin by conveyor and from the rear bin(s) by passing through a stainless steel metering wheel, material dividers and main spinner assembly. Bin sensors are installed to warn when materials are low in each micronutrient bin. The MultiBin can be easily removed from the main spreader for single-bin fertilizer or lime spreading.

- The MultiBin also comes equipped with an upper and lower material divider which improves material placement on the spinner for a more effective spread pattern.
- An optional micronutrient stainless steel cover which opens and closes with a stainless steel air cylinder is available.
- Screens installed on micronutrient bins keep large chunks of material out of the bins by breaking the material up as it enters the bins.



The conveyor and metering wheels are controlled through the insert conveyor control valves located on the right-hand side of the machine.

# VALUE STATEMENTS

## PRECISION APPLICATION

- 16-section swath width control
- 1/2 width spreading
- Last Pass Control
- Boundary spreading
- Automatic feedgate and fan frame control
- Precise independent spinner control and monitoring
- Up to 4 products

## EASE OF USE

- New Leader user interface
- System sensors
- Feed gate optimizer
- Diagnostic feedback
- Complete controller package installed
- Automatic feedgate and fan frame control

## EASE OF MAINTENANCE

- Centralized lubrication
- Manufactured to reduce adjustments
- Automatic chain tensioner
- 304 stainless steel cross tubes, mounts, and take-up brackets
- Automatic chain oiling
- System sensors

“ To **radically improve** the way dry nutrients are **applied**. ”



Go ahead, follow us.



# **NEW LEADER**

Manufactured by

**NEW LEADER MANUFACTURING**

1330 76th Avenue SW | Cedar Rapids, Iowa 52404

[information@newleader.com](mailto:information@newleader.com)

[www.newleader.com](http://www.newleader.com)

Ph. 800.363.8281

**Building the Best Since 1939**

