

NEW LEADER

MODEL L2020G4

UNIT SERIAL NUMBER _____

MANUAL NUMBER: 97373-D

EFFECTIVE 12/2008

***HIGHWAY EQUIPMENT COMPANY
1330 76TH AVE SW
CEDAR RAPIDS, IOWA 52404-7052***

PHONE (319) 363-8281

FAX (319) 632-3081

www.highwayequipment.com

BUILDING THE BEST SINCE 1939

Copyright 2003 Highway Equipment Company, Inc.

TABLE OF CONTENTS

Warranty	4
Preface	5
Safety	6
Safety Decal Installation and Maintenance	8
Safety Decal Illustrations.....	9
General Description	19
Dimensions & Capacities	20
Installation Instructions	21
Pump & PTO Requirements	21
Truck Requirements.....	22
Hydraulic Pump Installation	23
Hydraulic Pump Drive Shaft Installation	23
Mounting Spreader Body.....	24
Fender Installation	28
Electric Dump Valve Control	28
Hydraulic Hose Installation	29
Electrical Connections	32
Light Installation.....	32
Spinner Sensor	32
Filling Hydraulic System.....	32
Checking Installation.....	32
Initial Start-Up.....	33
Field Testing	34
General Operating Procedures.....	35
Lubrication & Maintenance.....	36
Hydraulic System	36
Hydraulic Hose	37
Conveyor Chain.....	38
#5 Conveyor Belt.....	39
Conveyor Gear Case	44
Lubrication of Bearings	45
Clean Up	45
Fasteners	45
Lubricant & Hydraulic Oil Specifications.....	46
Lubrication & Maintenance Chart.....	47
Troubleshooting.....	48
Torque Chart.....	51



TABLE OF CONTENTS CONTINUED

Instructions for Ordering Parts	52
Legend for Parts List Symbols	52
Parts List	
Mounting Angle.....	53
Feedgate & Jack.....	54
#5 Bottom	56
Conveyor Idler.....	58
Conveyor Drive	59
Encoder	60
Conveyor Chain Oiler.....	62
Pintle Chain	66
Conveyor Chain.....	67
Chain Shield.....	68
Wipers.....	70
Fenders.....	72
Inverted V	76
Cab Shield.....	77
Ladder	78
Hillside Flow Divider	79
Material Divider	80
Spinner Guard & Shields.....	81
24" Hydraulic Fans.....	82
Spinner Sensor	84
Reservoir.....	85
Reservoir/Pump Hydraulics.....	86
Twin Spinner Hydraulics.....	88
Mark Series Control Hydraulics	89
Manual Dual Hydraulics.....	92
Raven II with PWM Single Hydraulics	96
Raven II with PWM Dual Hydraulics	98
Gear Cases	100
Spinner Motor.....	104
Conveyor Motors.....	106
Spinner Control Valve.....	108
Lights	109
Decals	110
Control Valve.....	112
Mark V Valve	113
G4 Spread Pattern	Tab



**INSERT CURRENT
NEW LEADER WARRANTY**

PREFACE

PLEASE ! ALWAYS THINK SAFETY FIRST !!

The purpose of this manual is to familiarize the person (or persons) using this unit with the information necessary to properly install, operate, and maintain this system. These instructions cannot replace the following: the fundamental knowledge that must be possessed by the installer or operator, the knowledge of a qualified person, or the clear thinking necessary to install and operate this equipment. Since the life of any machine depends largely upon the care it is given, we suggest that this manual be read thoroughly and referred to frequently. If for any reason you do not understand the instructions, please call your authorized dealer or our Cedar Rapids, Iowa, Product Support Department at (319) 363-8281.

It has been our experience that by following these installation instructions, and by observing the operation of the spreader, you will have sufficient understanding of the machine enabling you to troubleshoot and correct all normal problems that you may encounter. Again, we urge you to call your authorized dealer or our Cedar Rapids Product Support Department if you find the unit is not operating properly, or if you are having trouble with repairs, installation, or removal of this machine.

We urge you to protect your investment by using genuine HECO parts and our authorized dealers for all work other than routine care and adjustments.

Highway Equipment Company reserves the right to make alterations or modifications to this equipment at any time. The manufacturer shall not be obligated to make such changes to machines already in the field.

This Safety Section should be read thoroughly and referred to frequently.

ACCIDENTS HURT!!!

ACCIDENTS COST!!!

ACCIDENTS CAN BE AVOIDED!!!



SAFETY



TAKE NOTE! THIS SAFETY ALERT SYMBOL FOUND THROUGHOUT THIS MANUAL IS USED TO CALL YOUR ATTENTION TO INSTRUCTIONS INVOLVING YOUR PERSONAL SAFETY AND THAT OF OTHERS. FAILURE TO FOLLOW THESE INSTRUCTIONS CAN RESULT IN INJURY OR DEATH.

In this manual and on the safety signs placed on the unit, the words “DANGER,” “WARNING,” “CAUTION,” and “NOTICE” are used to indicate the following:



DANGER

Indicates an imminently hazardous situation that, if not avoided, WILL result in death or serious injury. This signal word is to be limited to the most extreme situations and typically for machine components that, for functional purposes, cannot be guarded.



WARNING

Indicates a potentially hazardous situation that, if not avoided, COULD result in death or serious injury, and includes hazards that are exposed when guards are removed. It may also be used to alert against unsafe practices.



CAUTION

Indicates a potentially hazardous situation that, if not avoided, MAY result in minor or moderate injury. It may also be used to alert against unsafe practices.

NOTICE!

Is used for informational purposes in areas which may involve damage or deterioration to equipment but generally would not involve the potential for personal injury.

IMPORTANT!

Is used for informational purposes in areas which may involve damage or deterioration to equipment but generally would not involve the potential for personal injury.

The need for safety cannot be stressed strongly enough in this manual. At Highway Equipment Company, we urge you to make safety your top priority when operating any equipment. We firmly advise that anyone allowed to operate this machine be thoroughly trained and tested, to prove they understand the fundamentals of safe operation.

The following guidelines are intended to cover general usage and to assist you in avoiding accidents. There will be times when you will run into situations that are not covered in this section. At those times the best standard to use is common sense. If, at any time, you have a question concerning these guidelines, please call your authorized dealer or our factory at (319) 363-8281.



SAFETY**AVOID ACCIDENTS**

Most accidents, whether they occur in industry, on the farm, at home, or on the highway, are caused by the failure of some individual to follow simple and fundamental safety rules or precautions. For this reason, most accidents can be prevented by recognizing the real cause and doing something about it before the accident occurs.

Regardless of the care used in the design and construction of any type of equipment, there are many conditions that cannot be completely safeguarded against without interfering with reasonable accessibility and efficient operation.

A CAREFUL OPERATOR IS THE BEST INSURANCE AGAINST AN ACCIDENT. THE COMPLETE OBSERVANCE OF ONE SIMPLE RULE WOULD PREVENT MANY THOUSAND SERIOUS INJURIES EACH YEAR. THAT RULE IS:

NEVER ATTEMPT TO CLEAN, OIL OR ADJUST A MACHINE WHILE IT IS IN MOTION.

NATIONAL SAFETY COUNCIL

**CAUTION**

If spreader is used to transport chemicals, check with your chemical supplier regarding DOT (Department of Transportation) requirements.



SAFETY DECALS

MAINTENANCE INSTRUCTIONS

1. Keep safety decals and signs clean and legible at all times.
2. Replace safety decals and signs that are missing or have become illegible.
3. Replaced parts that displayed a safety sign should also display the current sign.
4. Safety decals or signs are available from your dealer's Parts Department or our Cedar Rapids factory.

INSTALLATION INSTRUCTIONS

1. **Clean Surface**
Wash the installation surface with a synthetic, free-rinsing detergent. Avoid washing the surface with a soap containing creams or lotion. Allow to dry.
2. **Position Safety Decal**
Decide on the exact position before application. Application marks may be made on the top or side edge of the substrate with a lead pencil, marking pen, or small pieces of masking tape. NOTE: Do not use chalk line, china marker, or grease pencil. Safety decals will not adhere to these.
3. **Remove the Liner**
A small bend at the corner or edge will cause the liner to separate from the decal. Pull the liner away in a continuous motion at a 180-degree angle. If the liner is scored, bend at score and remove.
4. **Apply Safety Decal**
 - a. Tack decal in place with thumb pressure in upper corners.
 - b. Using firm initial squeegee pressure, begin at the center of the decal and work outward in all directions with overlapping strokes. NOTE: Keep squeegee blade even—nicked edges will leave application bubbles.
 - c. Pull up tack points before squeegeeing over them to avoid wrinkles.
5. **Remove Pre-mask**
If safety decal has a pre-mask cover remove it at this time by pulling it away from the decal at a 180 degree angle. NOTE: It is important that the pre-mask covering is removed before the decal is exposed to sunlight to avoid the pre-mask from permanently adhering to the decal.
6. **Remove Air Pockets**
Inspect the decal in the flat areas for bubbles. To eliminate the bubbles, puncture the decal at one end of the bubble with a pin (never a razor blade) and press out entrapped air with thumb moving toward the puncture.
7. **Re-Squeegee All Edges.**



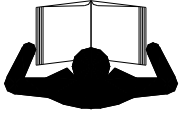

SAFETY DECALS CONTINUED

Note: Decals with "Notice" or "Important" are equal.

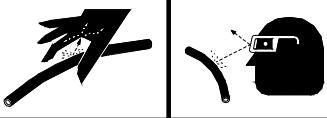
 CAUTION

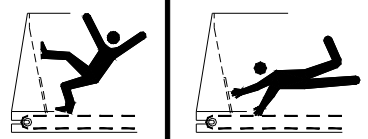
<p>TO AVOID INJURY OR MACHINE DAMAGE:</p> <ul style="list-style-type: none"> Do not operate or work on this machine without reading and understanding the operators manual. Keep hands, feet, hair and clothing away from moving parts. Do not allow riders on machine. Avoid unsafe operation or maintenance. Disengage power takeoff and shut off engine before removing guards, servicing or unclogging machine. Keep unauthorized people away from machine. Keep all guards in place when machine is in use. If manual is missing, contact dealer for replacement. <p style="text-align: right;">150034</p>

 WARNING

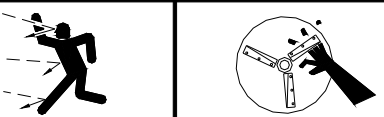
<p>HIGH PRESSURE FLUID HAZARD To prevent death or serious injury:</p> <ul style="list-style-type: none"> Relieve pressure on system before repairing, adjusting, or disconnecting. Keep all lines, fittings and couplers tight and free of leaks. Wear proper hand and eye protection when searching for leaks. Use wood or cardboard instead of hands. Do not use hydraulic lines for hand holds or steps. Components may be hot. <p style="text-align: right;">39138</p>

 DANGER

<p>MOVING PART HAZARD To prevent death or serious injury:</p> <ul style="list-style-type: none"> Stay out of box while conveyor is moving. Disconnect and lockout power source before adjusting or servicing. Do not ride on spreader. <p style="text-align: right;">364</p>

 DANGER

<p>FLYING MATERIAL & ROTATING SPINNER HAZARD To prevent death or serious injury:</p> <ul style="list-style-type: none"> Wear eye protection. Stop machine before servicing or adjusting. Keep bystanders at least 60 feet away. <p style="text-align: right;">368</p>



NOTICE
<p>Spinner assembly and material flow divider have NOT been adjusted at the factory. Before assembling unit, read and follow assembly instructions in the operation and maintenance manual for this unit.</p> <p>Before spreading material, spread pattern tests must be conducted to properly adjust the spread pattern. Refer to the "How to Check Your Spread Pattern" manual for adjustment instructions. A spread pattern test kit is available from your New Leader dealer.</p> <p>Wind, humidity, rain and other adverse weather conditions can affect spread pattern, resulting in uneven crop growth and loss of yield.</p> <p>THE MANUFACTURER OF THIS SPREADER WILL NOT BE LIABLE FOR MISAPPLIED MATERIAL DUE TO AN IMPROPERLY ADJUSTED SPREADER OR ADVERSE WEATHER CONDITIONS.</p> <p>It is recommended that spread pattern tests be conducted prior to each spreading season, after any spreader maintenance, and periodically during the spreading season. Spread pattern tests must be conducted whenever a new product is to be applied.</p> <p style="text-align: right;">71526-F</p>

 CAUTION
HAZARDOUS MATERIALS To avoid injury or machine damage: <ul style="list-style-type: none"> Materials to be spread can be dangerous. Improper selection, application, use or handling may be a hazard to persons, animals, crops or other property. Follow instructions and precautions given by the material manufacturer. <p style="text-align: right;">321</p>

 WARNING
MOVING PART HAZARD To prevent death or serious injury: <ul style="list-style-type: none"> Close and secure guards before starting. Do not stand or climb on machine. Disconnect and lockout power source before adjusting or servicing. Keep hands, feet and hair away from moving parts. <p style="text-align: right;">55631</p>

 WARNING

<p>FALLING HAZARD To prevent death, serious injury or machine damage:</p> <ul style="list-style-type: none"> Do not stand or climb on guard. <p style="text-align: right;">55630</p>

	 WARNING
<p>To prevent death or serious injury:</p> <ul style="list-style-type: none"> Do not place objects on fenders. Keep off fenders. They are not intended to carry loads. <p style="text-align: right;">39200</p>	



Please Give Part No., Description and Unit Serial No. 97373-D

GENERAL SAFETY RULES Operation Section

1. Before attempting to operate this unit, read and be sure you understand the operation and maintenance manual. Locate all controls and determine the use of each. Know what you are doing!
2. When leaving the unit unattended for any reason, be sure to:
 - a. Take power take-off out of gear.
 - b. Shut off conveyor and spinner drives.
 - c. Shut off vehicle engine and unit engine (if so equipped).
 - d. Place transmission of the vehicle in "neutral" or "park".
 - e. Set parking brake firmly.
 - f. Lock ignition and take keys with you.
 - g. Lock vehicle cab.
 - h. If on steep grade, block wheels.

These actions are recommended to avoid unauthorized use, runaway, vandalism, theft and unexpected operation during start-up.



3. Do not read, eat, talk on a mobile phone or take your attention away while operating the unit. Operating is a full-time job.
4. Stay out of the body while conveyor is operating. If it is necessary to get into the body for any reason, be sure all power is shut off, vehicle brakes are set, and the engine starting switch is locked and keys removed. All controls should be tagged to prohibit operation and tags should be placed and later removed only by the person who was working in the body.

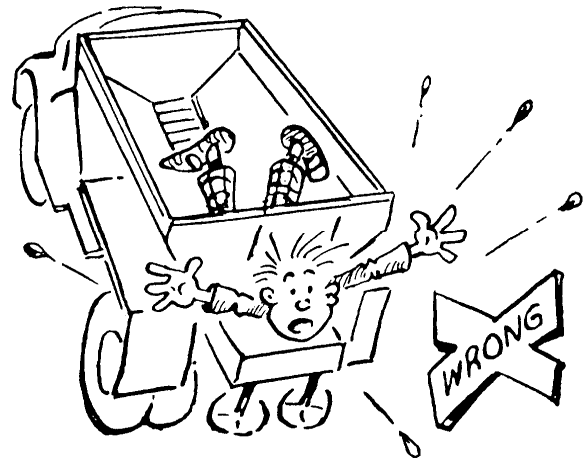

5. Guards and covers are provided to help avoid injury. Stop all machinery before removing them. Replace guards and covers before starting spreader operation.
6. Stay clear of any moving members, such as shafts, couplings and universal joints. Make adjustments in small steps, shutting down all motions for each adjustment.
7. Before starting unit, be sure everyone is clear and out of the way.

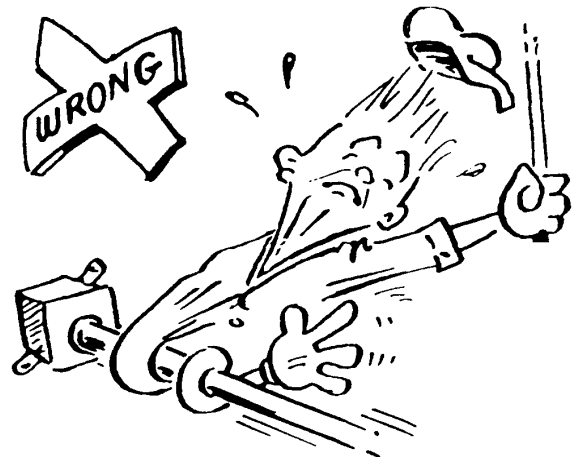

GENERAL SAFETY RULES Operation Section

8. Be careful in getting on and off this unit, especially in wet, icy, snowy or muddy conditions. Clean mud, snow or ice from steps and footwear.
9. Do not allow anyone to ride on any part of unit for any reason.

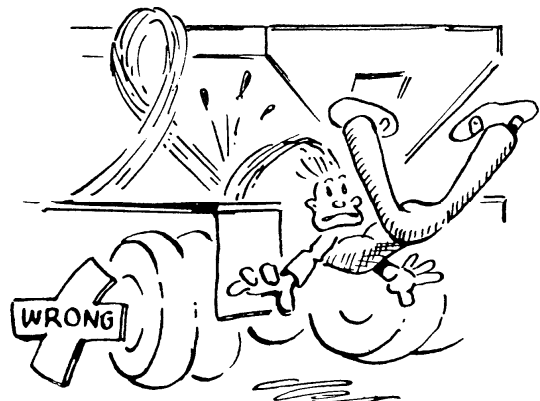
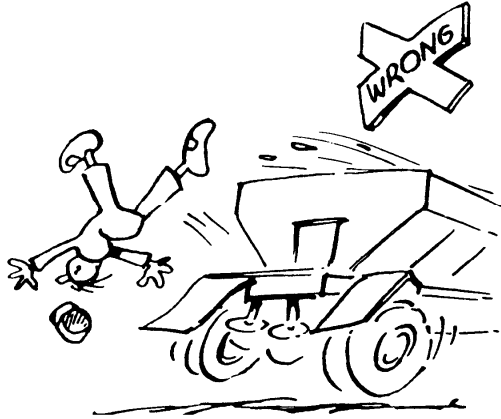

10. Keep away from spinners while they are turning:
 - a. Serious injury can occur if spinners touch you.
 - b. Rocks, scrap metal or other material can be thrown off the spinner violently. Stay out of discharge area.



11. Inspect spinner fins, spinner frame mounting and spinner fin nuts and screws every day. Look for missing fasteners, looseness, wear and cracks. Replace immediately if required. Use only new SAE grade 5 or grade 8 screws and new self-locking nuts.

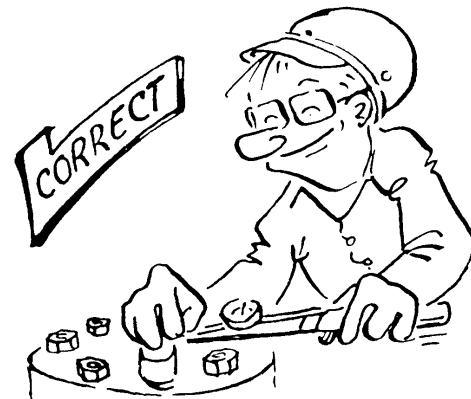

12. Inspect all bolts, screws, fasteners, keys, chain drives, body mountings and other attachments periodically. Replace any missing or damaged parts with proper specification items. Tighten all bolts, nuts and screws to specified torques according to the torque chart in this manual.

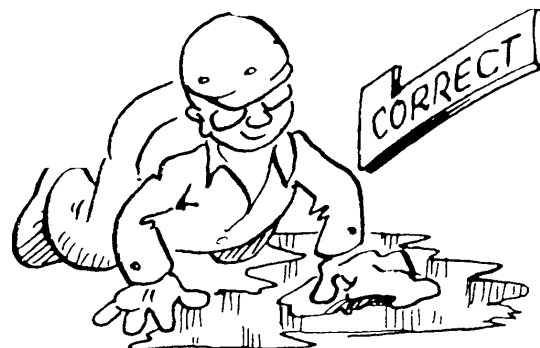

13. Shut off engine before filling fuel and oil tanks. Do not allow overflow. Wipe up all spills. Do not smoke. Stay away from open flame. FIRE HAZARD!



GENERAL SAFETY RULES Operation Section

14. Starting fluids and sprays are extremely flammable. Don't smoke. Stay away from flame or heat!
15. All vehicles should be equipped with a serviceable fire extinguisher of 5 BC rating or larger.
16. Hydraulic system and oil can get hot enough to cause burns. Before working on the system, wait until oil has cooled.
17. Wear eye protection while working around or on unit.
18. Read, understand and follow instructions and precautions given by the manufacturer or supplier of materials to be spread. Improper selection, application, use or handling may be hazardous to people, animals, plants, crops or other property.
19. Cover all loads that can spill or blow away. Do not spread dusty materials where dust may create pollution or a traffic visibility problem.



20. Turn slowly and be careful when traveling on rough surfaces and side slopes, especially with a loaded spreader. Load may shift causing unit to tip.

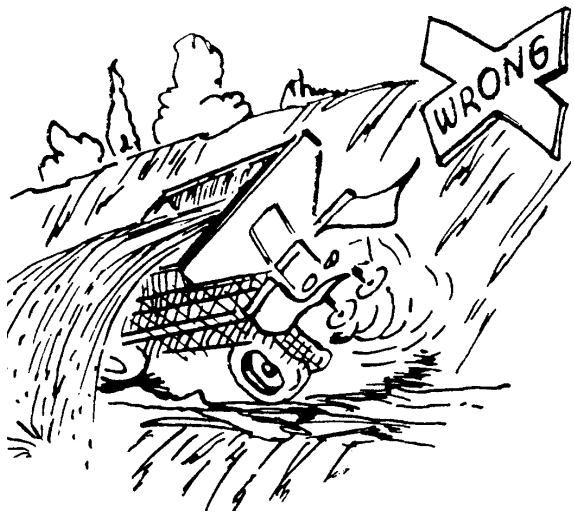
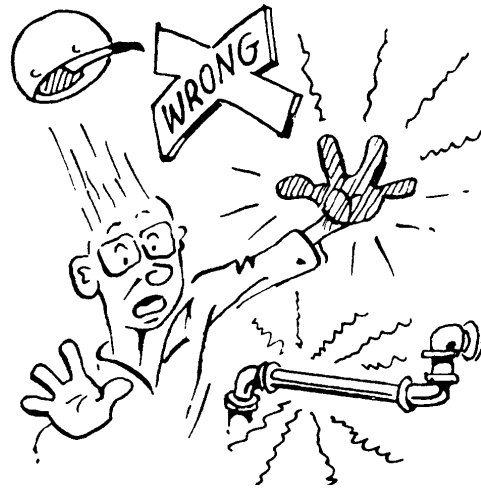

GENERAL SAFETY RULES

Operation Section

21. When using metering device, shut off spinner before placing box on hook or when removing it. Handle box with care to avoid injury.
22. Read and understand the precautionary decals on the spreader. Replace any that become defaced, damaged, lost or painted over. Replacement decals can be ordered from your equipment dealer or from Highway Equipment Company by calling (319) 363-8281.



GENERAL SAFETY RULES Maintenance Section

1. Maintenance includes all lubrication, inspection, adjustments (other than operational control adjustments such as feedgate openings, conveyor speed, etc.) part replacement, repairs and such upkeep tasks as cleaning and painting.
2. When performing any maintenance work, wear proper protective equipment—always wear eye protection—safety shoes can help save your toes—gloves will help protect your hands against cuts, bruises, abrasions and from minor burns—a hard hat is better than a sore head!
3. Use proper tools for the job required. Use of improper tools (such as a screwdriver instead of a pry bar, a pair of pliers instead of a wrench, a wrench instead of a hammer) not only can damage the equipment being worked on, but can lead to serious injuries. **USE THE PROPER TOOLS.**
4. Before attempting any maintenance work (including lubrication), shut off power completely. **DO NOT WORK ON RUNNING MACHINERY!**
5. When guards and covers are removed for any maintenance, be sure that such guards are reinstalled before unit is put back into operation.
6. Check all screws, bolts and nuts for proper torques before placing equipment back in service. Refer to torque chart in this manual.
7. Some parts and assemblies are quite heavy. Before attempting to unfasten any heavy part or assembly, arrange to support it by means of a hoist, by blocking or by use of an adequate arrangement to prevent it from falling, tipping, swinging or moving in any manner which may damage it or injure someone. Always use lifting device that is properly rated to lift the equipment. Do not lift loaded spreader. **NEVER LIFT EQUIPMENT OVER PEOPLE.**

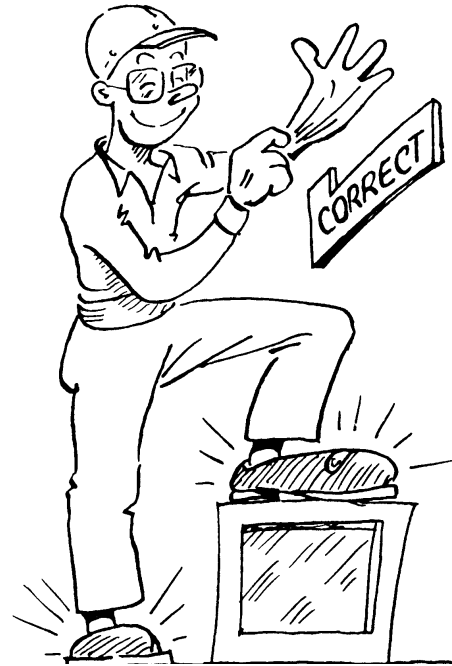

GENERAL SAFETY RULES Maintenance Section

8. If repairs require use of a torch or electric welder, be sure that all flammable and combustible materials are removed. Fuel or oil reservoirs must be emptied, steam cleaned and filled with water before attempting to cut or weld them. **DO NOT** weld or flame cut on any tank containing oil, gasoline or their fumes or other flammable material, or any container whose contents or previous contents are unknown.
9. Keep a fully charged fire extinguisher readily available at all times. It should be a Type ABC or a Type BC unit.
10. Cleaning solvents should be used with care. Petroleum based solvents are flammable and present a fire hazard. Don't use gasoline. All solvents must be used with adequate ventilation, as their vapors should not be inhaled.
11. When batteries are being charged or discharged, they generate hydrogen and oxygen gases. This combination of gases is highly explosive. **DO NOT SMOKE** around batteries—**STAY AWAY FROM FLAME**—don't check batteries by shorting terminals as the spark could cause an explosion. Connect and disconnect battery charger leads only when charger is "off". Be very careful with "jumper" cables.
12. Batteries contain strong sulfuric acid—handle with care. If acid gets on you, flush it off with large amounts of water. If it gets in your eyes, flush it out with plenty of water immediately and get medical help.
13. Hydraulic fluid under high pressure leaking from a pin hole are dangerous as they can penetrate the skin as though injected with a hypodermic needle. Such liquids have a poisonous effect and can cause serious wounds. Get medical assistance if such a wound occurs. To check for such leaks, use a piece of cardboard or wood instead of your hand. The fine spray from a small hydraulic oil leak can be highly explosive—**DO NOT SMOKE**—**STAY AWAY FROM FLAME OR SPARKS**.

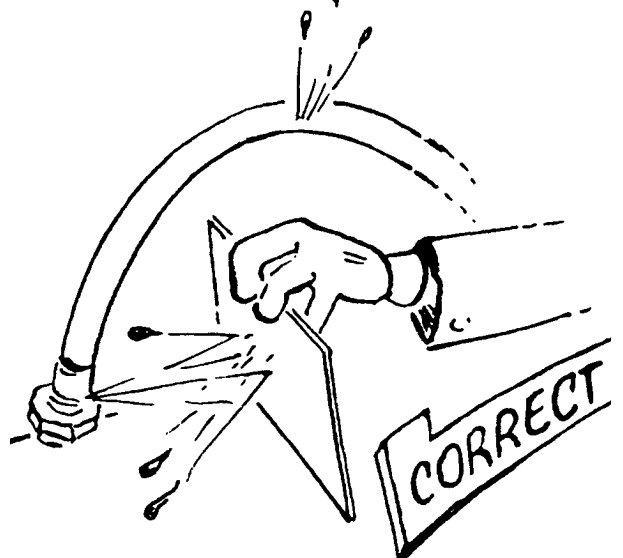
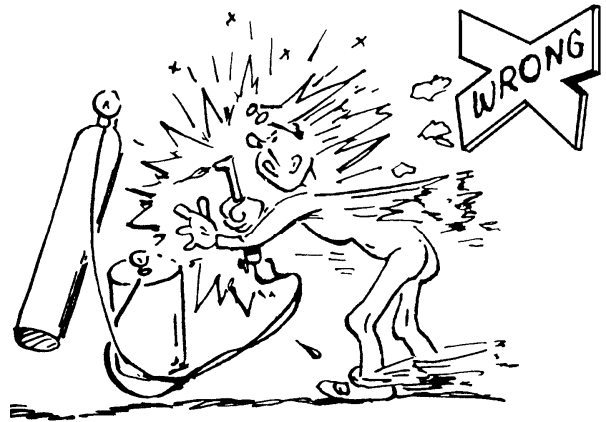

GENERAL SAFETY RULES Installation Section

1. The selection of the vehicle on which a spreader body is to be mounted has important safety aspects. To avoid overloading:
 - a. Do not mount spreader on a chassis which, when fully loaded with material to be spread, will exceed either the Gross Axle Weight Rating (GAWR) or the Gross Vehicle Weight Rating (GVWR) for the chassis.
 - b. Do install the spreader only on a vehicle with cab-to-axle dimension recommended for the spreader body length shown.
2. Follow mounting instructions in the Installation section of this manual. If mounting conditions require deviation from these instructions refer to factory.

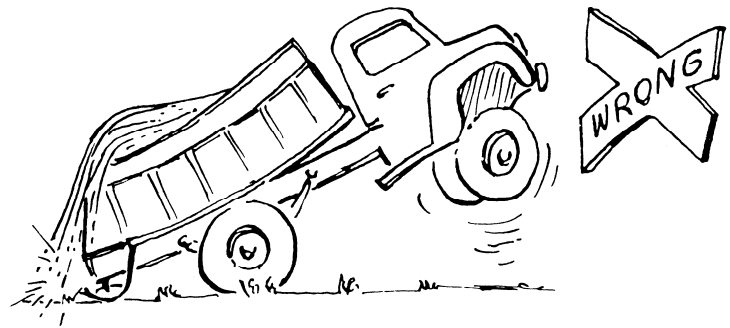
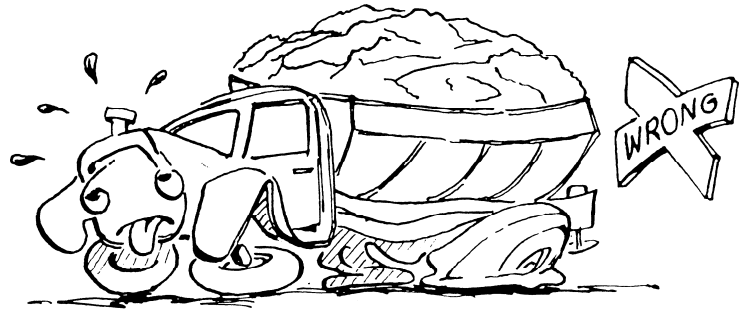

3. When making the installation, be sure that the lighting meets Federal Motor Vehicle Safety Standard (FMVSS) No. 108 and all applicable local and state regulations.
4. When selecting a PTO to drive hydraulic pump, do not use a higher percent speed drive than the Truck-PTO-Pump Match Graph indicates in the Installation section of this manual. Too high a percent PTO will drive pump at excessive speed, which can ruin the pump, but more importantly, will overheat the hydraulic oil system and increase the possibility of fire.

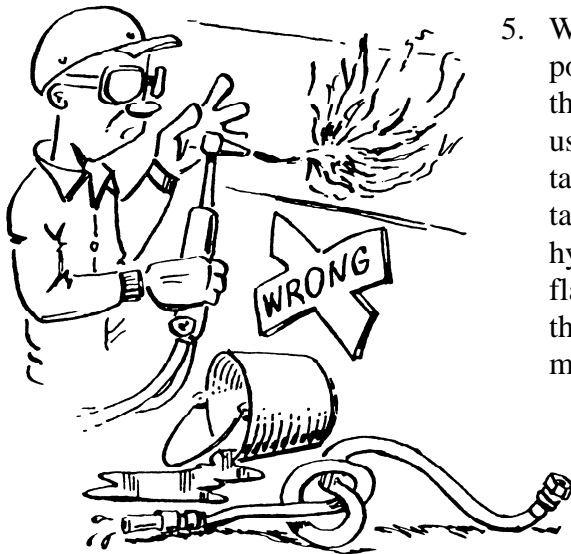

5. When truck frame must be shortened, cut off only the portion that extends behind rear shackle in accordance with the truck manufacturer's recommendations. If a torch is used to make the cut, all necessary precautions should be taken to prevent fire. Cuts should not be made near fuel tanks and hydraulic oil reservoirs, fuel, brake, electric or hydraulic lines and such lines should be protected from flame, sparks or molten metal. Tires should be removed if there is any chance of their being struck by flame, sparks or molten metal. Have a fire extinguisher handy.



GENERAL SAFETY RULES Installation Section

5. Do not weld on vehicle frame as such welding can lead to fatigue cracking and must be avoided. When drilling holes in frame member, drill only through the vertical web portions—do not put holes in top or bottom flanges. Refer to truck manufacturer's recommendations.

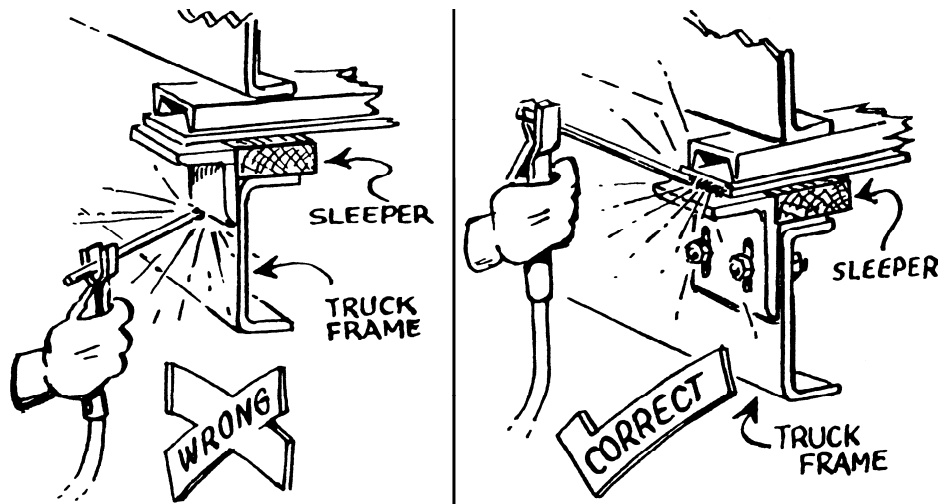

6. Be sure that welds between mounting bars and sill or between mounting angles and spreader cross sills are sound, full fillet welds. Center mounting angles so that good fillet welds can be made on three sides—and edge bead weld is not a satisfactory weld for this service. Use dry, E6013 or E7018 rod for normal steels. On stainless steel bodies use SAE grade 5 bolts—welding is recommended if type 308 welding rod is available.

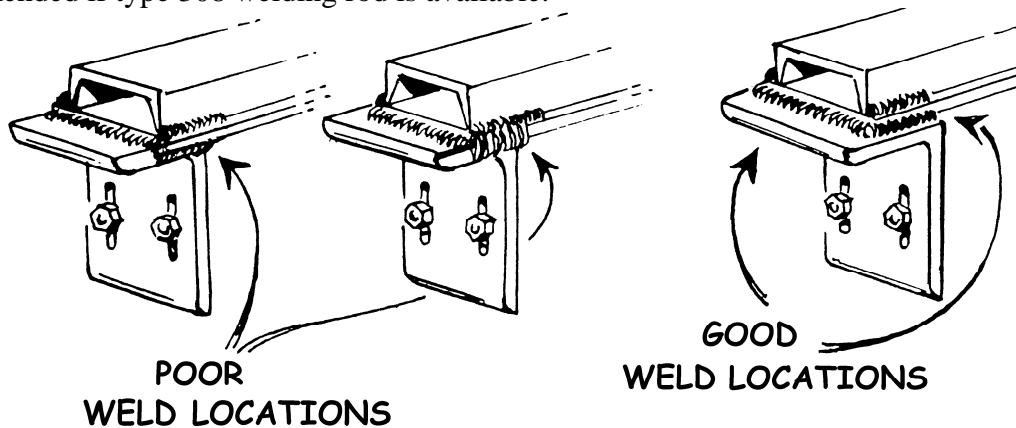

7. Install controls so that they are located of convenient use. Position them so that they do not interfere with any vehicle control and that they do not interfere with driver or passenger or with access to or exit from the vehicle.
8. Check for vehicle visibility, especially toward the rear. Reposition or add mirrors so that adequate rearward visibility is maintained.
9. Add Caution, Warning, Danger and Instruction decals as required. Peel off any label masking which has not been removed.
10. Install all guards as required.
11. Check installation completely to be sure all fasteners are secure and that nothing has been left undone.

NOTES:



GENERAL DESCRIPTION

The Model L2020G4 is a hopper-type spreader intended for spreading free-flowing granular agricultural materials, such as chemical fertilizers, agricultural limestone and gypsum. It is intended for truck chassis or flotation vehicle mounting. It also may be incorporated into a towed trailer unit.

The unit is powered hydraulically and provides independent variable speed control for the spinner. The conveyor has full automatic ground speed coordinated control by means of a motorized valve with shaft sensor or Mark series control system. The hydraulic pump, which provides the hydraulic power, is a gear-type pump that is driven by means of a transmission PTO.

The conveyor runs the full length of the hopper bottom to deliver material to the spinners through an adjustable metering gate at the rear of the hopper body. It is driven by an orbital type hydraulic motor integrally mounted to a 6 to 1 ratio spur gear box. The standard conveyor is a number five straight belt on ten foot through thirteen foot units and a number four Belt-over-chain on fourteen foot through sixteen foot units.

The distributor spinner assembly has two 24 inch (60.96cm) diameter dished discs. Each disc has four formed and heat treated fins. Each fin's angle can be adjusted. The spinner is fully adjustable by means of a rotating handle.

This product is intended for commercial use only.



DIMENSIONS & CAPACITIES

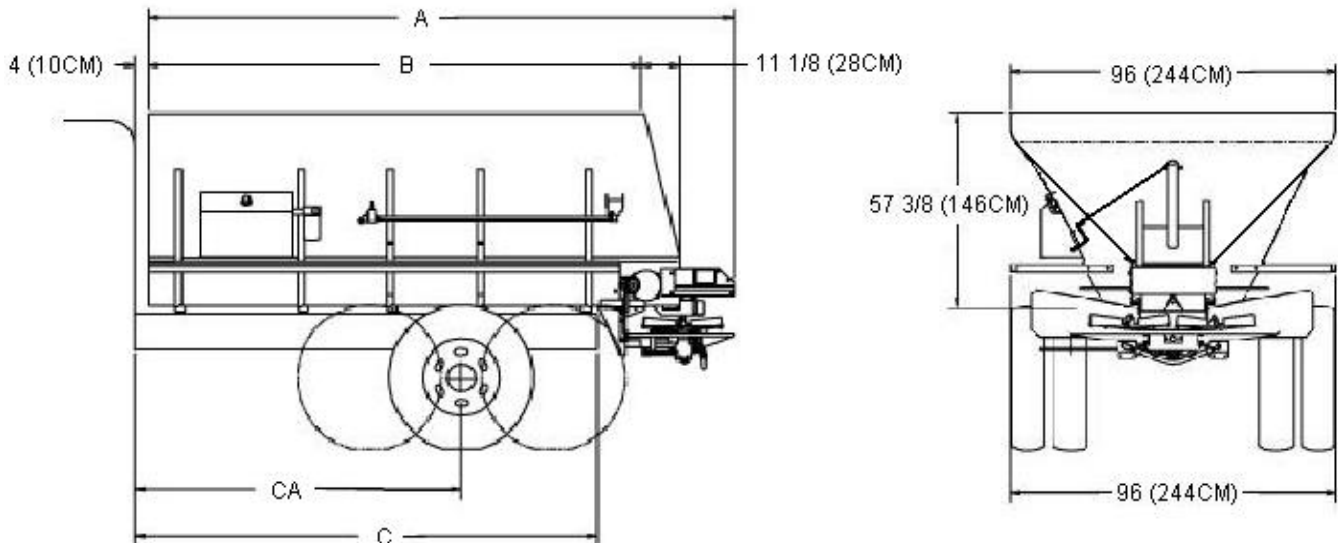

Dimensions				
Body Length	Overall A	Inside B	Frame C	Cab to Axle or Cab to Tandem CA/CT
10' (3.05m)	148" (376cm)	120" (305cm)	111" (282cm)	84" (213cm) CA
11' (3.35m)	160" (406cm)	132" (335cm)	123" (312cm)	84" (213cm) CA
12' (3.66m)	172" (437cm)	144" (366cm)	135" (343cm)	102" (259cm) CA
12'6" (3.81m)	178" (452cm)	144" (381cm)	141" (358cm)	102" (259cm) CA
13' (3.96m)	184" (467cm)	156" (396cm)	147" (373cm)	102-108" (259-274cm) CT
14' (4.27m)	196" (498cm)	168" (427cm)	159" (404cm)	120" (305cm) CT
15' (4.57m)	208" (528cm)	180" (457cm)	171" (434cm)	130" (330cm) CT
16' (4.88m)	220" (559cm)	192" (488cm)	183" (465cm)	138" (351cm) CT

Body Length	Capacities-Struck — Cubic Yards (Meters ³) Cubic Feet	
	Standard	Spreader Weight Approx. Pounds – As Shipped
10' (3.05m)	7.07 (5.41) 191	3745 lbs.
11' (3.35m)	7.83 (5.99) 211	3815 lbs.
12' (3.66m)	8.58 (6.56) 231	3885 lbs.
12'6" (3.81m)	8.58 (6.56) 231	3920 lbs.
13' (3.96m)	9.33 (7.13) 252	3955 lbs.
14' (4.27m)	10.09 (7.71) 272	4025 lbs.
15' (4.57m)	10.84 (8.29) 293	4095 lbs.
16' (4.88m)	11.59 (8.86) 313	4165 lbs.



INSTALLATION INSTRUCTIONS

Recommended sequence of installation is:

1. Mounting of PTO and pump drive.
2. Installation of radar (if applicable)
3. Mounting of spreader.
4. Installation of controller and encoder (if applicable)
5. Installation of hydraulic hose and electrical wiring.
6. Installation of optional parts.
7. Filling of hydraulic tanks and lubrication.
8. Checking for leaks and proper functioning.

NOTICE!

Pump and truck requirements must be determined prior to installation of the L2020G4.

PUMP AND PTO REQUIREMENTS:

Hydraulic Requirements

Maximum Pressure: 3100 PSI (213.7 b)
Flow: 28-30 GPM (106 – 113.6 LPM)

Sizing Data Required:

Since the amount of material per acre to be spread depends upon the match between pump size, pump speed (which depends upon engine speed and PTO percent), conveyor delivery rate and feedgate opening, it is essential that a correct match between these factors be made. This matching is called “sizing.”

1. Correct sizing requires accurate and complete information.
 - A. Engine governed operating speed.
 - B. Transmission make and model.
 - C. PTO Data
 1. Make and model of PTO.
 2. PTO percentage of engine RPM.
 3. Direction of PTO Rotation (Engine direction or opposite of engine direction).

NOTICE!

Excessive engine speed will cause more hydraulic oil to be pumped than is required to drive spinners and conveyor and may result in overheating the oil. Too low an engine speed may not provide sufficient hydraulic oil flow to maintain spread width or to keep the conveyor running at the speed required to deliver the desired quantity of material being spread.

NOTE: It may be necessary to select a higher percentage PTO or a larger pump than standard with lower speed engines, such as diesels and heavy duty gasoline engines. Consult your dealer in such cases. It is desirable to install a tachometer in order to maintain proper engine speeds.



INSTALLATION INSTRUCTIONS CONTINUED

2. Pump PTO Selection:

The following chart shows pumps available through Highway Equipment Company (HECO):

HECO Pump Part No.	% Efficiency	Pump CID	Required System GPM (LPM)	Required Pump RPM (95% efficiency)
86664	95	3.87	28 – 30 (106 – 113.6)	1760 – 1885
86665	95	4.38	28 – 30 (106 – 113.6)	1555 – 1665

To determine PTO (Power Take-Off) percentage:

$$(\text{REQUIRED PUMP RPM} \div \text{OPTIMAL ENGINE RPM}) \times 100 = \text{PTO}\%$$

To determine Engine RPM:

$$\text{REQUIRED PUMP RPM} \div (\text{PTO}\% \div 100) = \text{OPTIMAL ENGINE RPM}$$

NOTICE!

Do not select a PTO % and an engine RPM resulting in more than 3000 RPM. Driving the pumps (referenced above) at speeds greater than 3000 RPM will result in premature failure of the pump and other hydraulic components.

TRUCK REQUIREMENTS

In mounting the L2020G4 spreader on a truck, the following questions must be considered:

1. Is the CA/CT (Cab to Axle/Cab to Tandem) dimension of the truck correct for the length of the spreader?

See the Dimensions charts on page 20. This will assist in matching spreader to truck.

2. Is the truck's GAWR (Gross Axle Weight Rating) and the GVWR (Gross Vehicle Weight Rating) adequate to carry the fully loaded spreader?

Refer to your New Leader dealer. He knows where to find the GAWR and GVWR for most trucks, and how to calculate the weight distribution on each axle and total loaded vehicle weight.



INSTALLATION INSTRUCTIONS CONTINUED

HYDRAULIC PUMP INSTALLATION

A mounting bracket for the hydraulic pump is shipped with the spreader. It may be necessary to modify this bracket to fit your truck since many variable factors such as PTO make and model, muffler position, transmission make and model, etc., all affect the mounting position. **DO NOT WELD THE BRACKET TO THE TRUCK FRAME.** To do so may void the truck manufacturer's warranty.

Position the mounting bracket so that the pump drive shaft will be as straight possible. In no case should the angle of any universal joint exceed 15°. The pump shaft and PTO shaft should be parallel. (Figure 1)

HYDRAULIC PUMP DRIVE SHAFT INSTALLATION

The pump drive shaft included may be too long for some installations. It may be cut and redrilled as necessary. When redrilling the shaft, be sure that universal joints are properly "timed", as shown in Figure 1.

Install the slip joint at the end of the pump drive shaft. Failure to install the slip joint will result in bearing failure in pump, PTO or both.

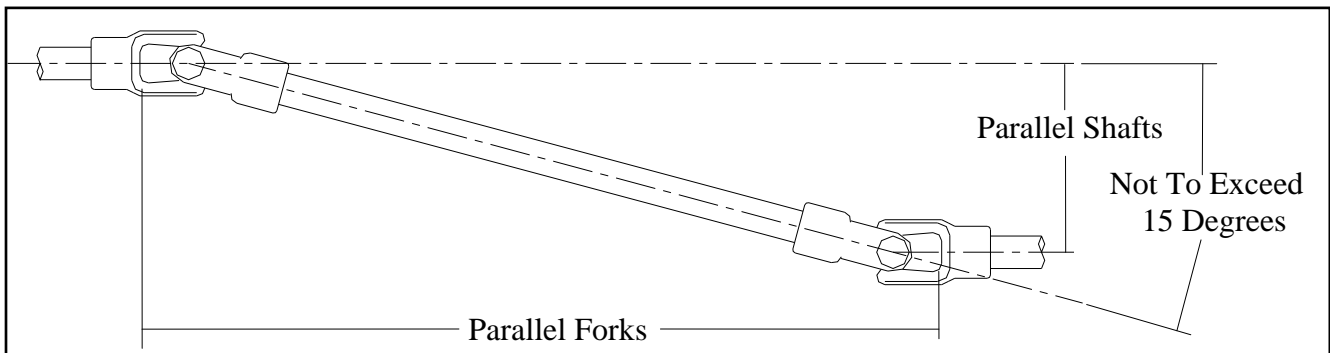

Figure 1 - Timing of Universal Joints

RADAR & CONTROLLER INSTALLATION



CAUTION

All holes in the truck cab walls, floor and firewall for control wires, hoses and cables are to be grommeted, plugged and sealed to prevent entrance of engine fumes, dust, dirt, water and noise.

See control manual for installation instructions of radar, control box and cable routing.

INSTALLATION INSTRUCTIONS CONTINUED

MOUNTING OF SPREADER BODY

Truck Frame Length

The length from the rear of the cab to the rear end of the frame should be approximately as shown on “Dimensions and Capacities” chart under “C”. Shorten truck frame as necessary, making sure to follow truck manufacturer’s specifications so as not to void truck warranty.

Filler Strips

NOTICE! Do not weld to truck frame; it may void truck warranty.

A level top surface is necessary for mounting. Add steel shim bars or strips the same thickness as fish plates or other obstructions and as wide as the truck frame channel top flange. Shims must be drilled to clear any rivet or bolt heads.

Units with rubber mounting pads do not require wood filler strips—continue to *Positioning Body* on next page. Rubber mounting pads may be ordered or follow instructions below if not so equipped.

Positioning Body



WARNING

Use only lifting devices that meet or exceed OSHA standard 1910.184. Never exceed work load limits or lift equipment over people. Empty spreader before lifting. Loads may shift or fall if improperly supported, causing injury.



WARNING

Keep unit supported until mounting is complete. Unit could slip off chassis, causing injury or damage to unit.

Using a suitable lifting device, lift empty spreader onto truck frame. Position body centrally with respect to truck frame rails and approximately 4" (10.16cm) from rear of cab. Check position of spreader at rear to insure rear mounting angle can be installed on truck frame and centered on rear cross tube.



INSTALLATION INSTRUCTIONS CONTINUED**Installing Front Mounting Angles**

NOTICE!	DO NOT PUT HOLES INTO TOP OR BOTTOM FLANGES —to do so may void truck manufacturer's warranty. When drilling holes in frame member, drill only through vertical web portions.
----------------	---

Assemble two front mounting angle springs and hardware. Use a 3/8" (.95cm) shim between cross tube mounting plate and truck frame mounting angle. Position assembly under second cross tube from front and against truck frame, make sure springs do not contact cross tube. Mark position of mounting angle holes on truck frame. Drill 9/16" (1.43cm) holes where marked and install mounting assembly using 1/2" hardware supplied. Weld mounting plate to bottom of cross tube on three sides, and remove 3/8" shim (Figure 3, page 27). Tighten spring assembly until spring compressed height is 4" (10.16cm). There should be a 3/8" (.95cm) space between cross tube mounting plate and truck frame mounting angle (Figure 2, page 26). Repeat this procedure on other side of truck frame, on same cross tube.

NOTE: It may be necessary to mount front mounting angle springs on first cross tube on some vehicles due to obstructions such as spring shackles etc.

Installing Center Mounting Angles (10 Foot (304.8cm) and 11 Foot (335.28) Bodies)

Position center mounting angles at a convenient cross tube near center of body with slotted faces against truck frame. Weld mounting angle to bottom of cross tube on three sides (Figure 3, page 27). Do not install hardware, these mounting angles are for side to side support only (Figure 2, page 26).

Installing Center Mounting Angles (12 Foot (365.76cm) to 16 Foot (487.68cm) Bodies)

Position center mounting angles at a convenient cross tube near center of body with slotted faces against truck frame and mark location of slots on truck frame. Drill 9/16" (1.43cm) diameter holes through truck frame approximately 3/4" (1.91cm) from bottom of slots (Figure 2). Weld mounting angle to bottom of cross tube on three sides (Figure 3). Install hardware and tighten to recommended torque.

NOTE: Position of center mounting angles will vary due to obstructions such as spring shackles, etc.



INSTALLATION INSTRUCTIONS CONTINUED

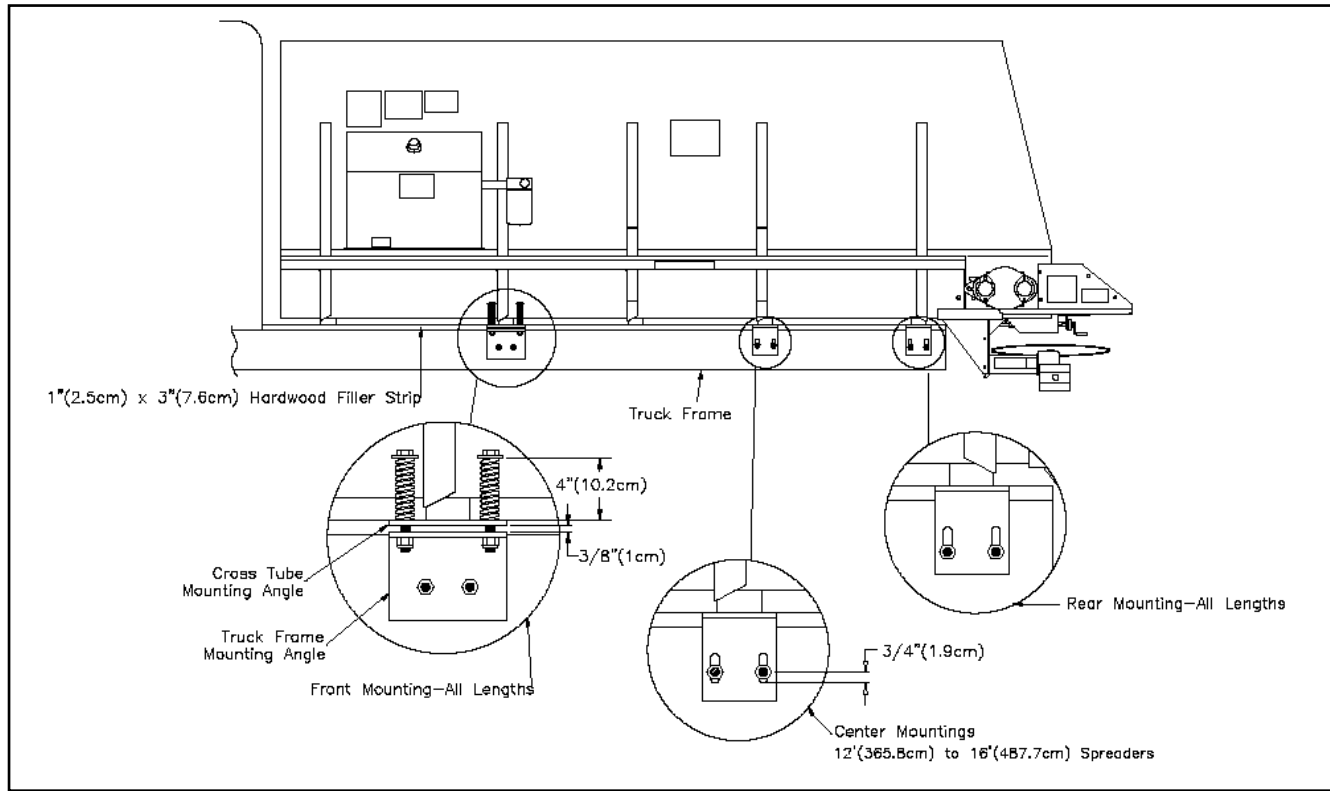

Figure 2 - Mounting Angle Installation

Installing Rear Mounting Angles



CAUTION

Make sure drill will not puncture gas tank or harm any other obstruction before drilling holes.

NOTICE!

DO NOT WELD ON VEHICLE FRAME! Such welding can lead to fatigue cracking and must be avoided.

Position rear mounting angles with the slotted faces against the side of the truck frame and centered on rear cross sill. Mark slot locations on truck frame. Drill 9/16" (1.43cm) diameter holes through truck frame at bottom end of slots (Figure 2). Weld mounting angle to bottom of cross tube on three sides (Figure 3). Install hardware and tighten to recommended torque.

INSTALLATION INSTRUCTIONS CONTINUED

Securing Spreader Body to Frame

NOTICE!

Connect welders ground directly to one of the items being welded anytime an arc welder is used on the vehicle or anything connected to the vehicle. Disconnect power cable from control box! Failure to do so can result in damage to components on both the vehicle and/or spreader, in which case the warranty will be null and void by manufacturer.

Install mounting angles and tighten mounting bolts to recommended torque. Weld mounting angles to spreader cross tubes by welding on front, outer and rear sides (Figure 4). Make sure welds between mounting angles and spreader cross tubes are sound full fillet welds. Center mounting angles so good fillet welds can be made on three sides, an edge bead weld is not a satisfactory weld for this service. Use dry E6013 or E7018 rod for mild steel spreaders and type 308 welding rod on stainless steel.

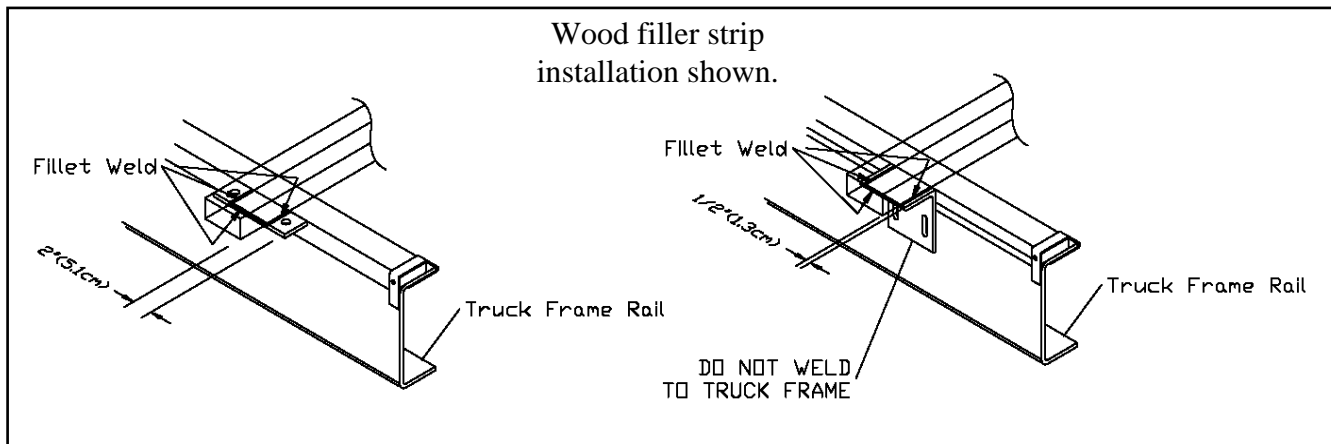

Figure 3 - Welding Instructions

INSTALLATION INSTRUCTIONS CONTINUED

FENDER INSTALLATION

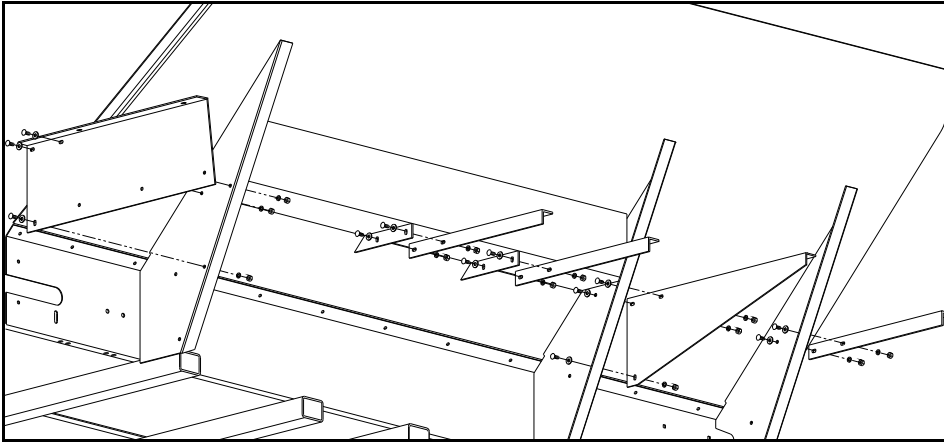

Figure 4 - Fender Angle Installation

Attach fender angles to spreader body as shown in Figure 4. Use upper set of holes for full or super floatation fenders and lower set of holes for semi-float and truck chassis mount fenders. Do not tighten hardware at this time.

NOTE: Some fenders have angles in place of panels shown.

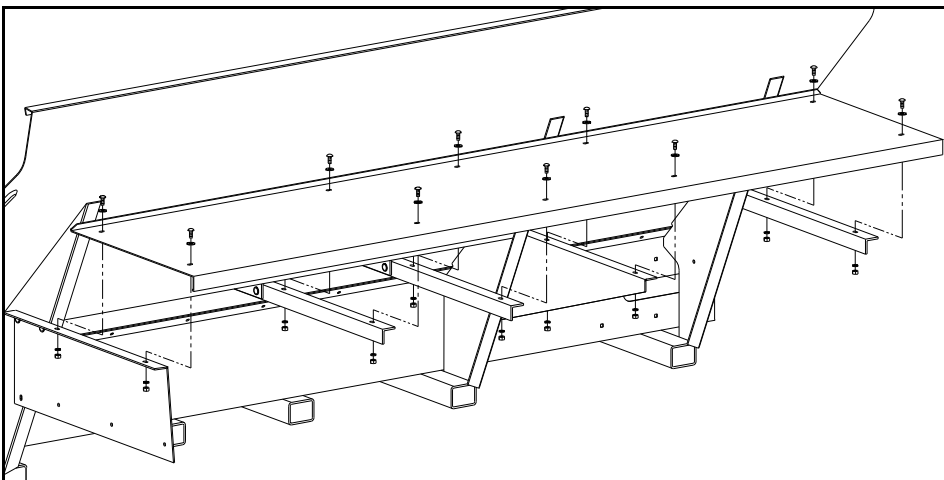

Figure 5 - Fender Installation

Attach fenders on top of angles/panels as shown in Figure 5. Tighten all hardware.

ELECTRIC DUMP VALVE CONTROL INSTALLATION

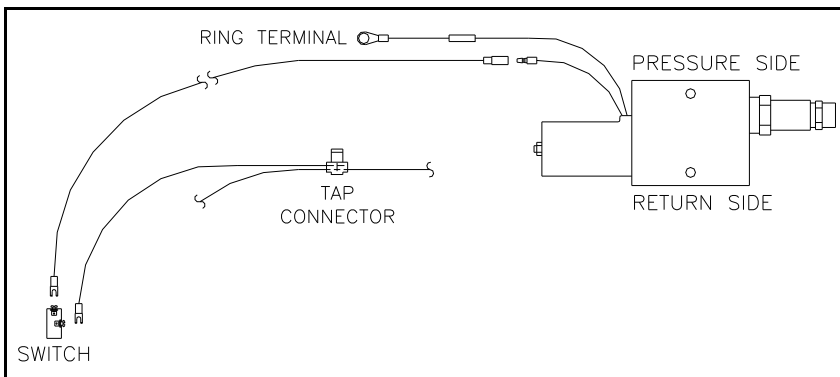

Figure 6 - Electric Dump Valve Control

Manual hydraulics only:

Splice wire from switch into wire with two amp to four amp fuse using tap connector. (See location of tap connector in Figure 6.) Ground ring terminal to chain shield hardware. Mount switch in dash or control panel in a location that is easily accessible while operating vehicle.

INSTALLATION INSTRUCTIONS CONTINUED

HYDRAULIC HOSE INSTALLATION

Determine the pressure port of the pump. Install the pressure hose into this port as shown in Figure 7. Connect the suction hose to the opposite port and to the tank outlet on the reservoir. If necessary, use plastic tie straps to support hoses so that they will not catch on field obstructions, contact the muffler or moving parts.

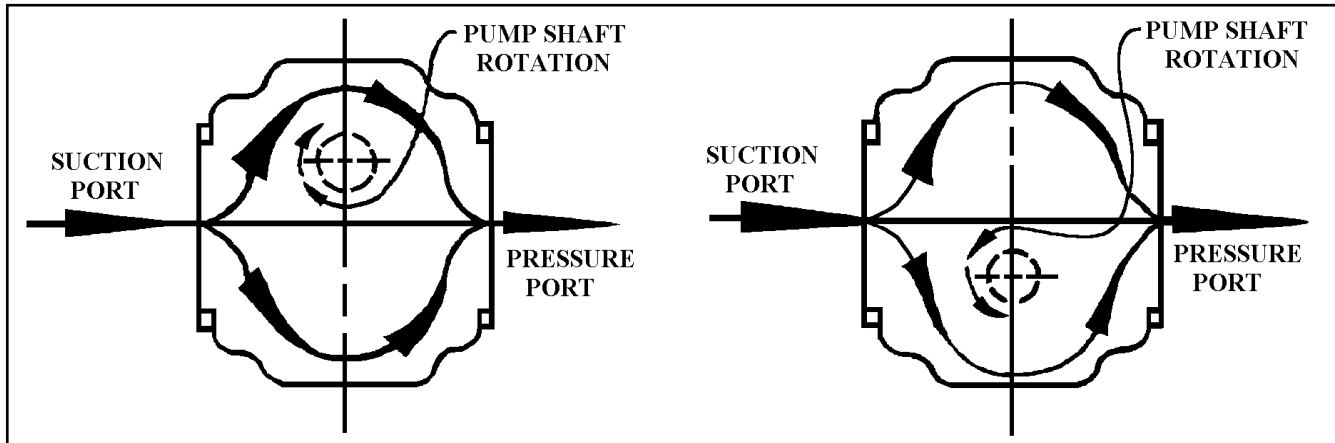

Figure 7 - Hydraulic Pump Installation

Use thread sealer on all fittings, except "O" ring and JIC adapters, "O" ring valves and motors, etc. When using thread sealer, do not put it on the first three threads of the fitting. Too much on the fitting or on the first three threads will force it into the oil stream where it could damage the system.



CAUTION

If a threaded connection is tightened too tightly, the fitting or housing into which the fitting is placed could be distorted and an unstoppable leak could occur.

Assemble the system as shown in the Hydraulics Parts List. Place the hose clamps as needed to keep hoses away from hot or moving parts. Do not let hoses hang so low as to be snagged. Do not stretch hoses tight.

The hydraulic hoses supplied are as follows:

Pressure Line: Two wire braid hose, one end fitting crimped on, other end fitting to be field installed after cutting hose to length. See assembly instructions on the following page.

Suction Line: Single spiral wire reinforced to be cut to length. Fittings to be assembled with double hose clamps.

All Return Lines: Double cotton braid with crimped end fittings.

INSTALLATION INSTRUCTIONS CONTINUED



WARNING

Do not use one manufacturer's hose with another manufacturer's fittings. Such use will void any warranty and may cause premature burst or leak of hydraulic fluids! Severe injury and/or fire could result!

Reusable Non-Skive Type Ends

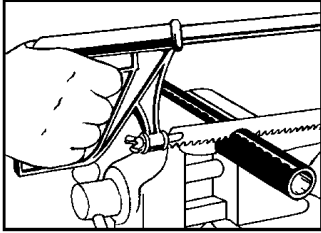

Step 1

Cut hose to length required using a fine tooth hacksaw or cut-off machine.

Clean hose bore.

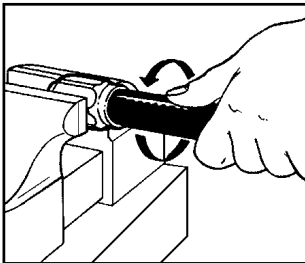

Step 2

Liberally lubricate hose cover with hose assembly lube.

Place socket in vise and turn hose into socket counterclockwise until it bottoms.

When assembling long lengths of hose, it may be preferred to put hose in the vise just tight enough to prevent from turning, and screw socket onto the hose counterclockwise until it bottoms.

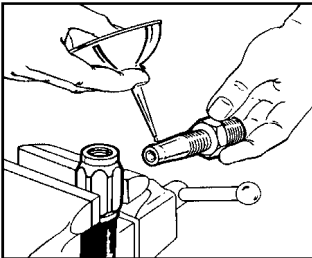

Step 3

Liberally lubricate nipple threads and inside of hose.

Use heavy weight oil.

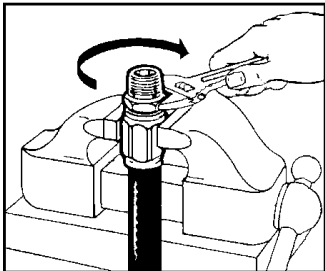

Step 4

Screw nipple clockwise into socket and hose.

Leave 1/32" (.08cm) to 1/16" (.16cm) clearance between nipple hex and socket.

Disassemble in reverse order.

Used with permission of the Aeroquip Company



INSTALLATION INSTRUCTIONS CONTINUED

Installation Guide

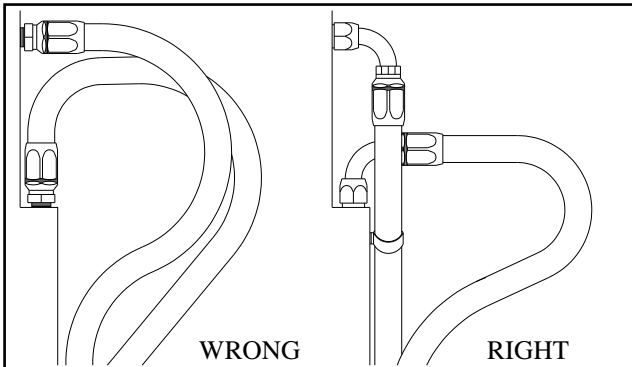

1. Use elbows and adapters in the installation to relieve strain on the assembly, and to provide easier and neater installations that are accessible for inspection and maintenance. Remember that metal end fittings cannot be considered as part of the flexible portion of the assembly.

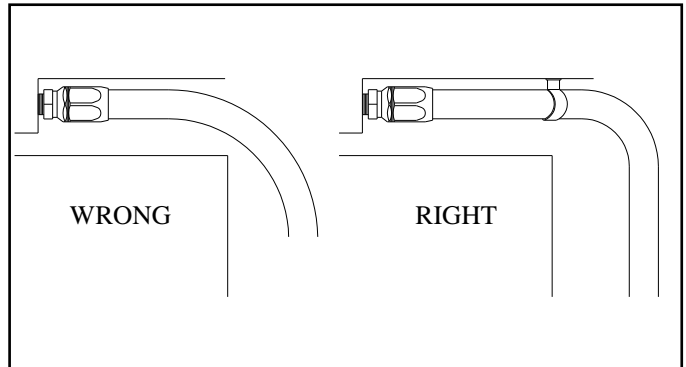

2. Install hose runs to avoid rubbing or abrasion. Clamps are often needed to support long runs of hose or to keep hose away from moving parts. It is important that the clamps be of the correct size. A clamp that is too large will allow the hose to move in the clamp causing abrasion at this point.

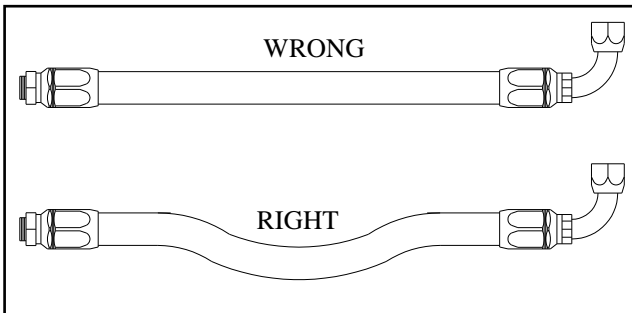

3. In straight hose installations allow enough slack in the hose line to provide for changes in length that will occur when pressure is applied. This change in length can be from +2% to -4%.

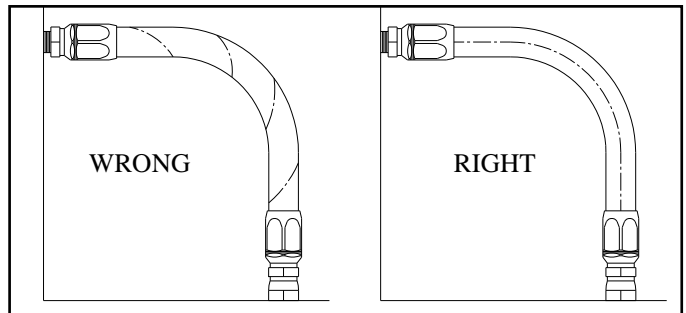

4. Do not twist hose during installation. This can be determined by the printed layline on the hose. Pressure applied to a twisted hose can cause hose failure or loosening of the connections.

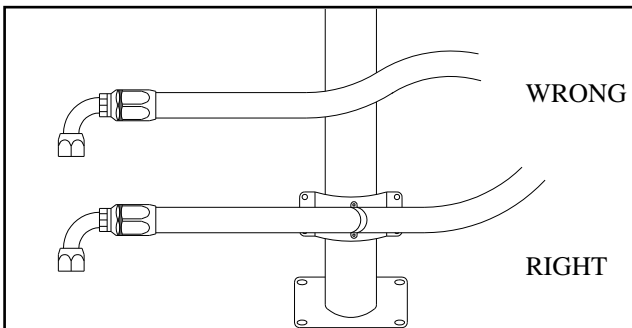

5. Keep hose away from hot parts. High ambient temperature will shorten hose life. If you cannot route it away from the heat source, insulate it.

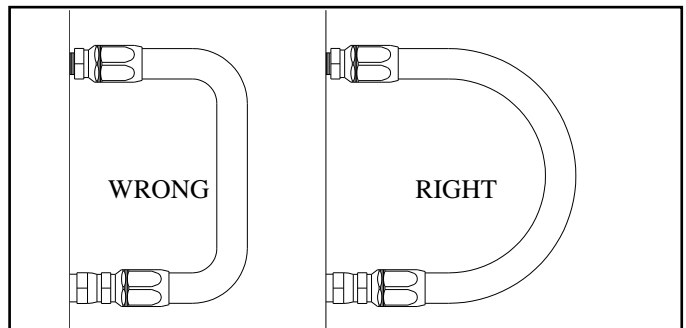

6. Keep the bend radii of the hose as large as possible to avoid hose collapsing and restriction of flow. Follow catalog specs on minimum bend radii.

(Used with the permission of The Weatherhead Company.)



Please Give Part No., Description and Unit Serial No. 97373-D

INSTALLATION INSTRUCTIONS CONTINUED**ELECTRICAL CONNECTIONS**

Connect all electrical control circuits. The supply conductor should be connected to the accessory terminal of the truck ignition switch through the fifteen amp. circuit breaker provided in the control panel. All wiring should be approved automotive insulated wire, supported adequately with insulating ties or straps, and located where it will not interfere with any control or access. Make sure wiring does not contact any moving parts or sharp edge and is kept away from any hydraulic line or any heated part.

LIGHT INSTALLATION

Light installation must comply with all applicable requirements prescribed by FMVSS/CMVSS 108, state and local regulations. See “Lights” parts list and instructions below for example of installation.

Use two belt reflector mounts to attach rear red reflectors if mudflaps are not installed. Mount three lamp cluster to rear endgate. Mount red lamps on back of fenders facing rearward and amber lamps at the opposite end of fenders facing forward.

SPINNER SENSOR

The spinner sensor must be mounted under the right-hand spinner disc in the holes provided. Rotate the disc so that one of the cap screws is directly above the sensor. Position the sensor 1/8-inch (.32cm) or less below the cap screw and tighten the sensor hardware. If the distance between the sensor and the spinner cap screw is more than 1/8 inch (.32cm), the sensor may not get a good RPM reading. See “Spinner Sensor” parts list for illustration.

FILLING HYDRAULIC SYSTEM**NOTICE!**

DO NOT attempt to run pump without first filling hydraulic oil reservoir and opening suction line gate valve, or pump may be ruined.

Fill reservoir with hydraulic oil as specified in the “Lubricant Specifications” section of this manual. Be sure oil is clean, free from dirt, water and other contaminants.

Lubricate all points requiring lubrication per “Lubrication Chart” in this manual.

CHECKING INSTALLATION

See “Initial Start-Up” procedure.



INITIAL START-UP



WARNING Stand clear of moving machinery.

NOTE: Do not load spreader with material.

1. Check over entire unit to be sure all fasteners are in place and properly tightened per "Fastener Torque Chart" in this manual.
2. Make sure no other persons are in vicinity of truck or spreader.
3. Make sure no loose parts are in unit or on conveyor or spinner.
4. Open feedgate until it is completely clear of conveyor.
5. Check oil level in hydraulic reservoir; fill as necessary. Refer to "Lubricant Specification" section of this manual for proper oil. Completely open gate valve under reservoir.
6. Set throttle so engine runs at about 1000RPM. Engage PTO driving pump. Allow pump to run and circulate oil for several minutes. Increase warm-up time in cold weather.
7. Manual spinner control valve: Move to position "3".
PWM spinner control valve: Run at 300 RPM.
Spinner should run at slow speed. Allow to run until it is operating smoothly and all air has been purged.
8. Manual spinner control valve: Move to position "0".
PWM spinner control valve: Run at 0 RPM.
9. Place control in manual mode (see control manual) and run conveyor until it's operating smoothly.
10. Manual spinner control valve: Move to position "5".
PWM spinner control valve: Run at 500 RPM.
Allow both spinner and conveyor to run. Shut down system.



WARNING

DO NOT check leaks with hands while system is operating as high pressure oil leaks can be dangerous! DO NOT check for leaks adjacent to moving parts while system is operating as there may be danger of entanglement!

11. Check all connections in hydraulic system to make sure there are no leaks.
12. Check hydraulic oil reservoir and refill to maintain level around mid-point of sight gauge.
Unit is now ready for field testing.



FIELD TESTING

The following procedure is a guide:

1. Field test over any suitable course which allows vehicle to be driven at speeds to be used while spreading.
2. Make sure unit has been properly serviced, that oil reservoir is full and gate valve under reservoir is fully open. Do not load spreader.
3. Manual spinner control valve: Set to position "7".
PWM spinner control valve: Run at 700 RPM.



DANGER

Take proper safety precautions when observing conveyor and spinner speed while vehicle is in motion! These may include use of suitable mirrors clamped to permit observation by a safely seated observer, following the spreader in another vehicle at a safe distance, or other suitable means. Do not stand on fenders, in body or on any part of spreader as there is danger of falling off the vehicle or into moving parts! Use great care in performing this test!

4. Turn control to "on" position. Engage PTO and allow to run at fast idle long enough to bring hydraulic oil up to operating temperature. Spinners should revolve at moderate speed. Conveyor should not move.
5. Set program in control console to operational mode and begin forward travel. Move conveyor switch to "on" position. Conveyor should start immediately when vehicle moves and should continue to run at speeds which vary directly with the vehicles field speed; the conveyor should speed up as truck speed increases and slow down as truck speed reduces. Spinner speed should remain constant when engine speed is above minimum operating range.

GENERAL OPERATING PROCEDURES

1. Make sure unit has been properly serviced and is in good operating condition. Field test unit prior to first use, prior to each spreading season's use, and following overhaul or repair work, to verify that all components and systems are functioning properly. See "Field Testing" section.
2. Fill body with material to be spread.
3. Drive to location where spreading is to be done.
4. Adjust spinner control valve for material being applied to give spread width desired. See "G4 Spread Pattern" section.
5. Adjust spinner to give spread pattern desired. See "G4 Spread Pattern" section.
6. Set feedgate opening to obtain yield desired. Measure actual material depth.
7. Make sure shut-off valve on hydraulic reservoir is fully opened.
8. Turn on power to controller and set program to desired values.
9. Engage pump drive PTO.



CAUTION Drive only at speeds which permit good control of vehicle!

10. Drive at speeds that allow engine to turn at proper RPM.

Higher transmission gears may be used with speeds to 30 MPH. If lower speeds must be used, shift transmission into lower gears so engine speed can be maintained to allow adequate hydraulic oil delivery from pump.

NOTICE!

CHANGE THE HYDRAULIC OIL FILTER AFTER THE FIRST WEEK (OR NOT MORE THAN 50 HOURS) OF OPERATION ON A UNIT.



LUBRICATION & MAINTENANCE

PREVENTATIVE MAINTENANCE PAYS!

The handling and spreading of commercial fertilizers is a most severe operation with respect to metal corrosion. Unless a frequent, periodic preventative maintenance program is established, rapid damage to spreading equipment can occur. Proper cleaning, lubrication and maintenance will give you longer life, more satisfactory service and more economical use of your equipment.



WARNING

Shut off all power and allow all moving parts to come to rest before performing any maintenance operation.

HYDRAULIC SYSTEM

Proper oil in the hydraulic system is one of the most important factors for satisfactory operation. Utmost cleanliness in handling the oil cannot be stressed enough. Keep hydraulic oil in original closed containers, clean top of container before opening and pouring, and handle in extremely clean measures and funnels.

Refer to “Lubricant and Hydraulic Oil Specifications” section of the manual for selection of the proper hydraulic fluid for use in the hydraulic system.

Service Schedule

1. Check hydraulic oil daily by means of sight gauge on reservoir. Add oil if required. Periodically inspect hoses and fittings for leaks.



WARNING

DO NOT check leaks with hands while system is operating as high pressure leaks are very dangerous! DO NOT check for leaks adjacent to moving parts while system is operating as there may be danger of

2. Change hydraulic oil filter after first week (or not more than 50 hours) of operation on a unit.
3. After first filter change, replace filter when indicator reaches Red Zone.
4. Drain reservoir through drain plug (not through suction outlet), flush, and refill and change filter element annually. Oil and filter should also be changed whenever oil shows any signs of breaking down under continued high-pressure operation. Discoloration of oil is one sign of breakdown.



LUBRICATION & MAINTENANCE CONTINUED

HYDRAULIC HOSE

Hose assemblies in operation should be inspected frequently for leakage, kinking, abrasion, corrosion or any other signs of wear or damage. Worn or damaged hose assemblies should be replaced immediately.

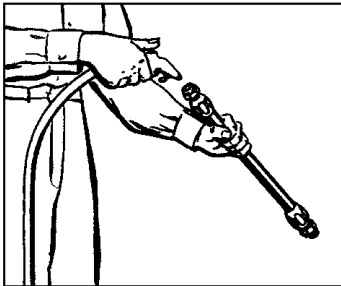

Clean

Clean assembly by blowing out with clean compressed air. Assemblies may be rinsed out with mineral spirits if the tube stock is compatible with oil, otherwise hot water at 150 degrees F maximum may be used.

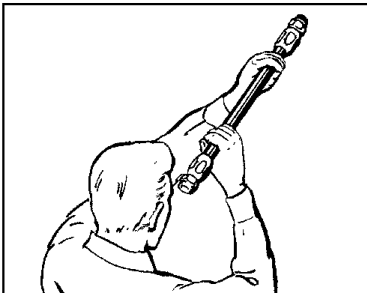

Inspect

Examine hose assembly internally for cut or bulged tube, obstructions, and cleanliness. For segment style fittings, be sure that the hose butts up against the nipple shoulder; band and retaining ring are properly set and tight, and segments are properly spaced. Check for proper gap between nut and socket or hex and socket. Nuts should swivel freely. Check the layline of the hose to be sure the assembly is not twisted. Cap the ends of the hose with plastic covers to keep clean.

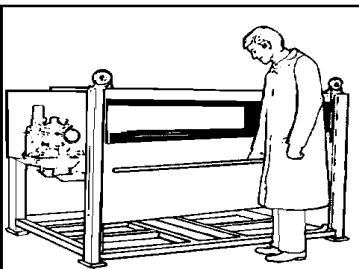

Test

The hose assembly should be hydrostatically tested at twice the recommended working pressure of the hose. Test pressure should be held for not more than one minute and not less than 30 seconds. When test pressure is reached, visually inspect hose assembly for: 1. Any leaks or signs of weakness. 2. Any movement of the hose fitting in relation to the hose. Any of these defects are cause for rejection.



WARNING

Testing should be conducted in approved test stands with adequate guards to protect the operator.

Storage and Handling

Hose should be stored in a dark, dry atmosphere away from electrical equipment, and the temperature should not exceed 90° F (32.22° C).



Please Give Part No., Description and Unit Serial No. 97373-D

LUBRICATION & MAINTENANCE CONTINUED

CONVEYOR CHAIN

Hose down unit and remove any material build-up on sprockets and under chain.

NOTICE!

The conveyor will move away from the bottom panel if material accumulates under the conveyor or on the sprockets. The more material that accumulates, the closer the chain will come to the chain shields. If the conveyor should catch a chain shield, it could permanently damage the conveyor, the chain shields or the unit. Do not remove material while conveyor or spinner is running!

Lubricate conveyor chain daily. Shut down spinner and run conveyor slowly to lubricate chain. Use a mixture of 75% fuel oil and 25% SAE 10 oil in a pressurized hand spray gun. Spray oil mixture between links of chain through openings provided at rear end of sill or from front outside body when clearance is adequate. After each unit washing, allow to dry, then lubricate.



DANGER

Stay out of body when conveyor is running. Stay clear of all moving parts. Entanglement of clothes, any part of your body or anything you have in your hands can cause serious injury. Do not use a bar, rod or hammer on conveyor while it is moving—if it gets caught it could cause injury!

If a chain oiler is used, fill oiler reservoir daily with a mixture of 75% fuel oil and 25% SAE 10 oil. Before each filling of unit with material to be spread, open petcock and run conveyor until full length of chain has been oiled, then shut petcock.

Proper chain tension is also a factor in chain and sprocket life (Figure 8). Measure from rear of unit forward to achieve proper chain tension. Make sure chain is tensioned equally on both sides. This adjustment is made on each side of the unit at the idler bearings.

Chain Tension to be Measured from Rear of Sill – Proper Tension 36" to 40" (91cm to 102)

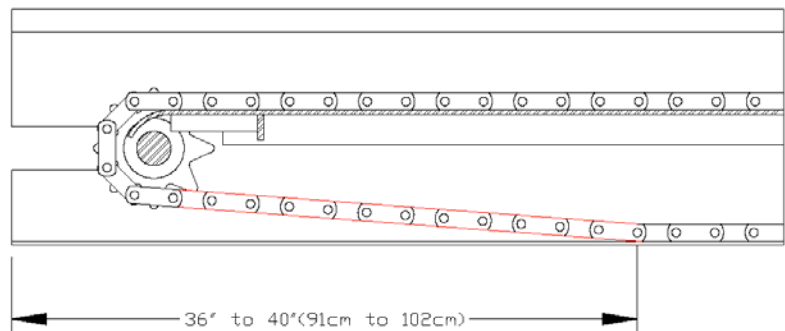

Figure 8 - Adjusting Chain Tension

Conveyor chains that are too tight will tend to stretch, causing excess sprocket wear and eventually breakage. Excess slack presents the possibility of chain catching on sub-frame parts. Bent or distorted chain bars will cause damage as well. Straighten or replace bent or distorted chain bars immediately.



LUBRICATION & MAINTENANCE CONTINUED

#4 CONVEYOR BELT

Standard belt for the #4 chain has a nylon fabric that is impervious to moisture, weathering or normal action except oil.

- Inspect belt fastener occasionally for wear or "raveling" of belt grip area.
- Make sure belt connecting pin is positioned correctly as shown in Figure 9.

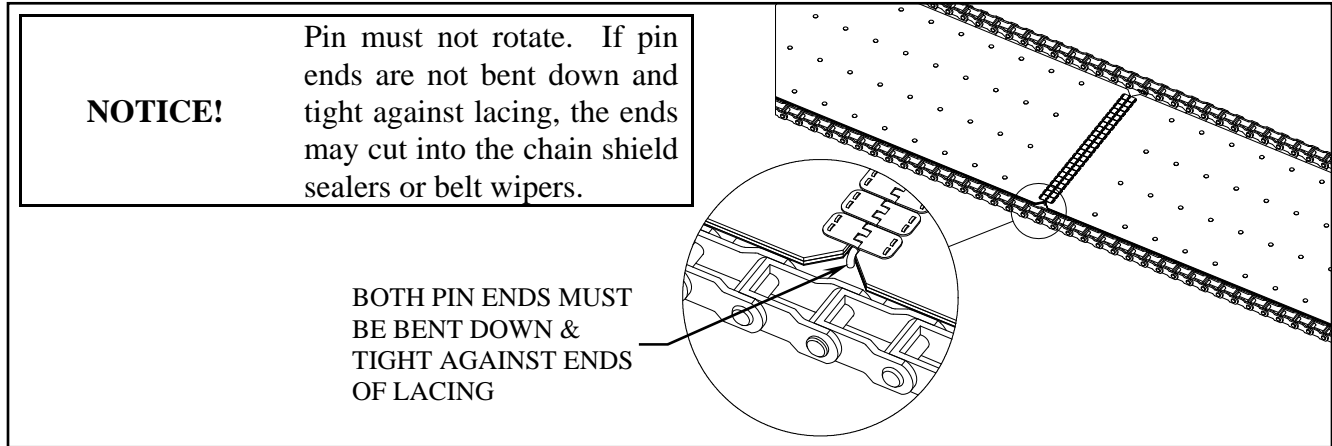

Figure 9 – Conveyor Belt Pin Installation

#5 CONVEYOR BELT

Maintenance

The conveyor belt should be checked daily for proper tension and tracking. See *Adjustment* section.

Do not be alarmed as sides of belt wear unless belt is out of track. The belt will continue to operate satisfactorily with up to 1" (2.54cm) total worn from the sides. Inspect belt lacing frequently for wear or "raveling" of belt grip area and loosening hardware. Retighten loose nuts and peen end of lacing screw into slot of nut as required.

LUBRICATION & MAINTENANCE CONTINUED

Adjustment

1. TENSION

Belt tension should be just tight enough to prevent slippage—no tighter. If the “flats” on the conveyor drive pulley are visible through the belt, tension is high enough.

2. TRACKING

Empty spreader to check tracking by doing the following:

A. Make sure truck engine is shut off and move spinner control valve to “0” position. Start truck engine and engage pump drive PTO. Spinners should not turn. If they do, correct the problem before proceeding.



WARNING

Do not work near rotating spinners. Severe injury can result from contact with moving parts.

B. Run truck engine, place controller in manual mode (see control manufacturer’s manual) and run conveyor at slow speed. Gradually increase speed until tracking is visual.



CAUTION

Use great care to avoid entanglement with any moving parts.

A properly adjusted belt will either remain in a steady position centered on the pulley or more often will “wander” back and forth 1/4 (.64cm) to 1/2 inch (1.27cm) across the pulley, but remain generally centered. The conveyor belt sides should not curl or scuff.

Improper tracking is usually due to three basic causes. These problems and their respective solutions follow:

PROBLEM 1: (Figure 10)

Belt tracks to one side, contacts side of conveyor. Contact is more severe at the front and may not quite touch at the rear.

SOLUTION:

Tighten idler bearing at side in contact with belt. Make this adjustment one turn at a time. Operate conveyor 10 to 15 minutes at a high speed to allow belt to react to the adjustment. Repeat if necessary.

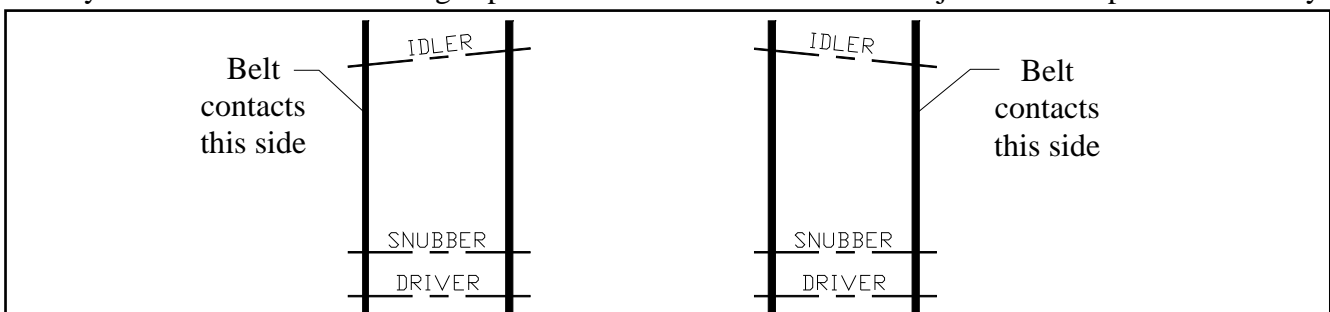

Figure 10



LUBRICATION & MAINTENANCE CONTINUED

PROBLEM 2: (Figure 11)

Belt contacts one side at front and contacts other side at rear.

SOLUTION:

If adjusting as in Problem 1 does not remedy the situation, adjustment of the drive pulley is necessary. Mark the position of the adjustment screw (RH side) on the side of the unit. Determine which illustration shows the problem to figure out which direction the drive shaft should be moved. Loosen the adjustment screw to move the shaft forward; tighten the screw to move the shaft rearward.

NOTE: The illustration is exaggerated. Only move the adjustment screw 1/4 (.64cm) turn at a time after loosening the bolts holding the bearing. Usually, 1/64 (.04cm) to 1/32 (.08cm) inch adjustment is all that is necessary. Retighten bearing. Operate conveyor for 10 to 15 minutes at a high speed to allow belt to react to adjustment. The problem should change to Problem 1. Adjust as in Problem 1 to track belt properly.

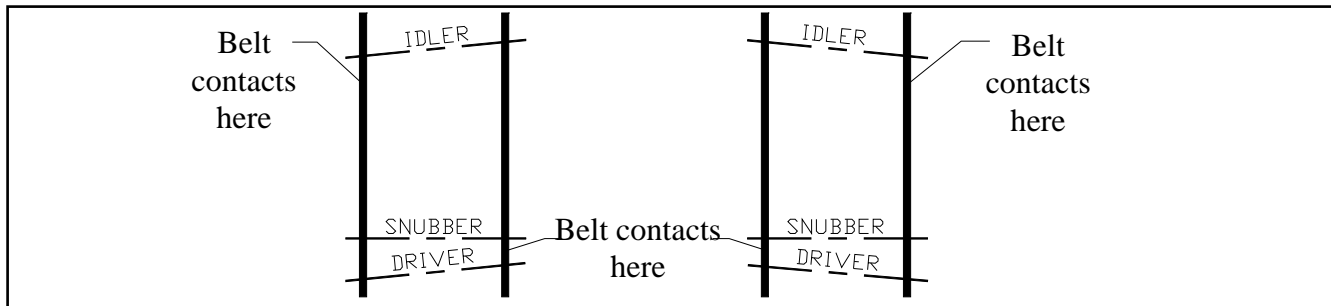

Figure 11

PROBLEM 3: (Figure 12)

Belt contacts side as in Problem 1, but contacts more heavily at a point approximately three feet from rear.

SOLUTION:

Realign snubber pulley. Note the point or side of contact from the illustration. This side of the snubber is too low. NOTE: This pulley moves up and down ONLY.

Loosen belt and raise or lower as necessary. Loosen the two bolts holding the snubber bearing on the side to be adjusted after marking the old position. Move approximately 1/16 (.16cm) inch at a time and retighten. Retighten belt the exact number of turns previously loosened. Operate conveyor 10 to 15 minutes to allow belt to react to adjustment. Refer to Problem 1 and readjust. If readjustment does not compensate, repeat.

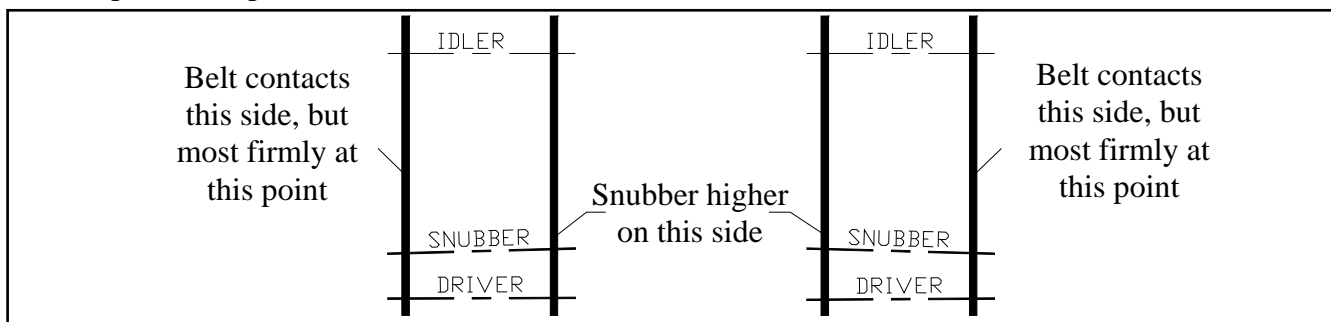

Figure 12



LUBRICATION & MAINTENANCE CONTINUED

If, after continued adjustment, the belt does not track properly, check the following:

1. Check for twisted spreader body. Shims must be placed between spreader cross tubes and the mounting surface to eliminate any twist in the body structure.
2. Check for crowned Idler Pulley by placing a straight edge on the pulley. If properly crowned, the straight edge will contact the center pulley leaving 1/16 (.16cm) inch gap between the straight edge and both pulley ends. Replace the pulley if crown is not present.
3. Check for lacing squareness by removing the belt. This should be done as a last resort. If the lacing is not square to the belt ends, contact your dealer for service.
4. Sight down the body under the belt shields. The only point which should come close to or slightly contact the belt, is the lowest point on the shield. If the belt contacts the shield firmly at any other point, tracking will be impossible and you should see your dealer immediately. Only your dealer can correct the situation.

Shield

The belt shields along each side of the belt inside the unit should be just contacting the belt when the belt is properly adjusted and the unit is empty (Figure 13). If a shield has clearance along its length, it can be moved down until it just contacts the belt by loosening the fastener bolts, allowing the shield to slide downward and tightening the bolts. If the shield is tending to cut into the belt along its full length, loosening the bolts and raising the shield until it just contacts the belt will correct the problem.

If the shield cuts the belt at one or more points or if it gaps at one or more points, it should be replaced.

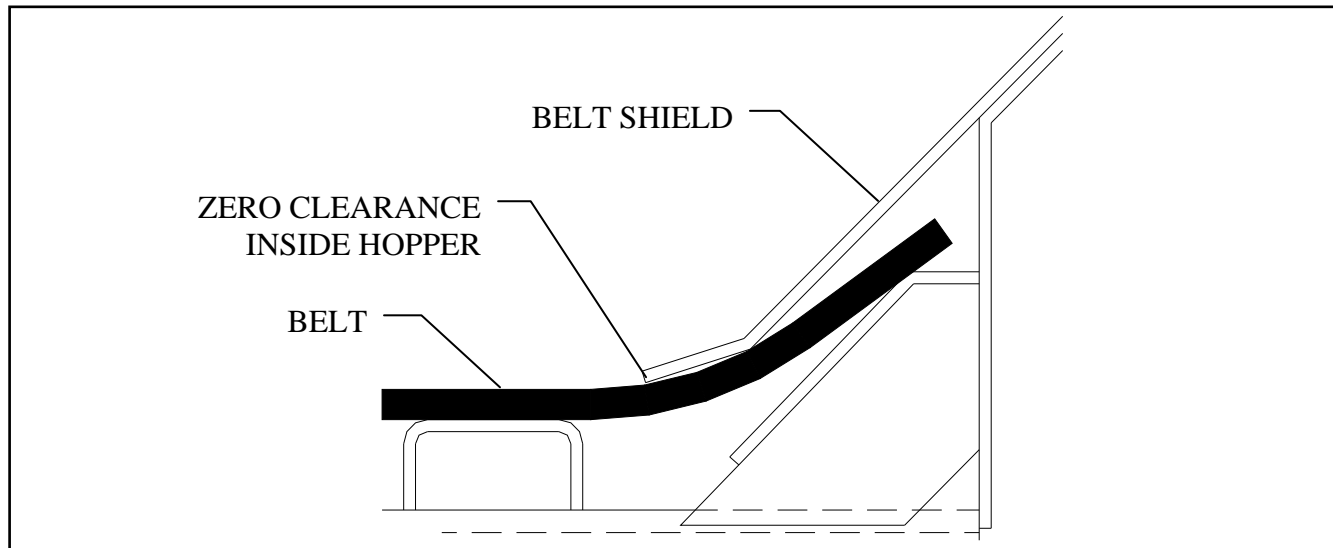

Figure 13 - #5 Bottom

NOTICE!

Don't lubricate the #5 belt. Use of lubricants will cause the belt to deteriorate and fail prematurely.



Please Give Part No., Description and Unit Serial No.

97373-D
Page Rev. A

LUBRICATION & MAINTENANCE CONTINUED**Removal & Replacement****Tools and Equipment Required:**

1. 1 1/2" Hex Wrench
2. 25 (762cm) to 30 (914.4cm) Feet of 1/4" (.64cm) to 3/8" (.95cm) Rope.
3. 3 or 4 Pieces of 2 x 4 (5.08cm x 10.16cm) Lumber about 3 Feet (91.44cm) Long.
4. 10 Feet (304.8cm) of 14 or 16 Gauge Soft Iron Wire.

NOTE: Two people **MUST** be used for this procedure.

Parts Required: See Parts Pages.

Procedure:

1. Set spinner control valve at "0" position to stop spinners.
2. Remove both belt shields, clean thoroughly and repaint.
3. Adjust processor to Manual operation. Select a slow Manual Speed so tracking is visual.
4. Move the front idler adjustment bolts to extreme rear position.
5. Shut down spreader. Pull out splice pin to separate belt splice.
6. Insert pin into one side of belt splice. Attach a winch to the belt splice and remove belt.
NOTE: If the splice pin cannot be removed, cut belt and remove belt by hand.
7. Using any suitable tool, remove any caked material from the drive pulley, snubber pulley, idler pulley and from inside the frame channels. Clean and repaint as required.
8. Thread OLD splice pin through one end of new belt splice. Connect wire to pin about 1/4" (.64cm) in from each side of the belt, forming a loop.
9. Thread the rope along the top of the belt channel, around the front idler pulley, over the snubber pulley, and under the drive pulley.



CAUTION Make sure power is shut off before performing threading operation.

10. Tie end of rope under drive pulley to wire loop. Wrap other end of rope once around drive pulley and out to rear.
11. Start conveyor drive so drive pulley turns slowly. One person should pull on rope while other feeds belt into unit from rear. Pull new belt under drive pulley, over snubber pulley, along frame channels, around front idler pulley and back to drive pulley.



LUBRICATION & MAINTENANCE CONTINUED



CAUTION

Use extreme care to avoid entanglement! Someone must stay at controls to stop conveyor instantly if required.



CAUTION

Use extreme care to avoid entanglement! Stand well back from drive pulley.

12. Shut off all power and insert lumber under belt to support its weight as shown in Figure 14.
13. Insert a plastic tube in each splice and across the full width of the belt and pull the two ends together at the center of the rear face of the drive pulley.
14. Insert the splice pin (flexible, plastic covered).
15. Snug the belt up by tightening the idler pulley.
16. Tighten the belt until the edge of the belt is approximately 2" (5.08cm) above the lower edge of the sill lower flange on each side. Remove lumber.
17. Adjust for proper tracking as outlined in the *Belt Conveyor Adjustment* section of this manual.

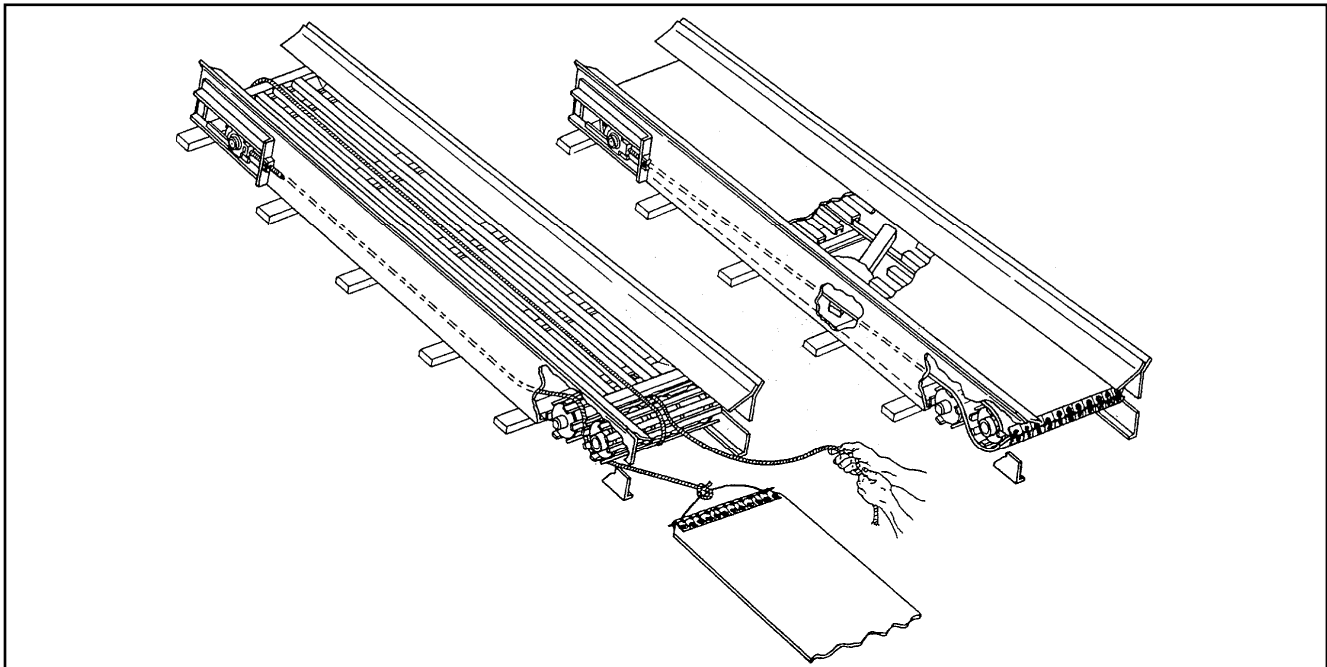

Figure 14 – #5 Belt Installation

CONVEYOR GEAR CASE

Oil in a new unit should be drained after first two weeks (or not more than 100 hours) of operation and gear case should be thoroughly flushed with light oil. Refer to “Lubricant Specifications” section for proper grade oil. Refill gear case with one pint (.47 liters) of recommended lubricant. After initial change, oil should be changed every 2,000 hours of operation or annually, whichever occurs first.

Check gear case oil level monthly.



LUBRICATION & MAINTENANCE CONTINUED

LUBRICATION OF BEARINGS

Grease in a bearing acts to prevent excessive wear of parts, protects ball races and balls from corrosion and aids in preventing excessive heat within the bearing. It is very important the grease maintains its proper consistency during operation. It must not be fluid and it must not channel.

Lubricate bearings by pumping grease slowly until it forms a slight bead around the seals. This bead indicates adequate lubrication and also provides additional protection against the entrance of dirt.

Make sure all fittings are thoroughly cleaned before grease is injected. Points to be lubricated by means of a grease gun have standard grease fittings.

CLEAN UP

NOTICE!

High pressure wash can inject water and/or fertilizer into control components, causing damage. Use caution when cleaning these areas.

Thoroughly wash unit every two to three days during the operating season to maintain minimal maintenance operation. Hose unit down under pressure to free all sticky and frozen material.

It is important the unit be thoroughly cleaned at the end of each operating season. All lubrication and maintenance instructions should be closely followed. Repaint worn spots to prevent formation of rust.

FASTENERS

Tighten all screw fasteners to recommended torque's after first week of operation and annually thereafter. If loose fasteners are found at any time, tighten to the recommended torque. Replace any lost or damaged fasteners or other parts immediately. Check body mounting hardware every week.



LUBRICANT & HYDRAULIC OIL SPECIFICATIONS

NOTICE!

The lubricant distributor and/or supplier is to be held responsible for results obtained from their products. Procure lubricants from distributors and/or suppliers of unquestionable integrity, supplying known and tested products. Do not jeopardize your equipment with inferior lubricants. No specific brands of oil are recommended. Use only products qualified under the following oil viscosity specifications and classification recommended by reputable oil companies.

HYDRAULIC SYSTEM

Use premium quality lubricants with 100-200 SUS or 20-43 cSt viscosity at operating temperatures. The hydraulic fluid's specifications in the table below are for normal operating conditions. Extreme environments or dirty conditions may require the use of different oils. Consult your New Leader dealer or the Product Support Department at Highway Equipment Company for systems operating outside normal conditions.

Ideal Oil Operating Temperature	140 - 190° F (56.1-76.2° C)
Recommended Premium Lubricant	Automotive Engine Oil
Lubricant Specifications: Viscosity Index Viscosity at 40°C, cst Viscosity at 100°C, cst	Greater than 130 Less than 115 Greater than 14
Acceptable Fluid Example	Valvoline All-Fleet Plus® SAE 15W-40

GEAR CASE LUBRICANT

Lubricate these assemblies with non-corrosive type SAE 90 E.P. (extreme pressure) gear oil conforming to MIL-L2105 B multi-purpose gear lubricating oil requirements (API Service GL 4) with ambient temperatures from 40° to 100° F (4.44 to 37.77° C). Ambient temperatures below 40° F (4.44° C) require SAE 80 E.P. lubricant; above 100° F (37.77° C) use SAE 140 E.P. grade oil.

GREASE GUN LUBRICANT

Use a waterproof ball and roller bearing lithium base lubricant with a minimum melting point of 300° F (148.8° C). This lubricant should have a viscosity which assures easy handling in the pressure gun at prevailing atmospheric temperatures. The grease should conform to NLGI No. 2 consistency.

CHAIN OILER LUBRICANT

Use a mixture of 75% No. 1 or No. 2 diesel fuel or kerosene mixed with 25% SAE 10 engine oil.

NOTICE!

Don't lubricate the #5 belt. Use of lubricants will cause the belt to deteriorate and fail prematurely.



LUBRICATION & MAINTENANCE CHART**WARNING**

Shut off all power and allow all moving parts to come to a rest before performing any maintenance operation.

The spreader should be regularly lubricated with the lubricants recommended in this manual in accordance with the following chart:

<u>LOCATION</u>	<u>PLACES</u>	<u>METHOD</u>	<u>FREQUENCY</u>
Transmission PTO			
Slip Yoke	1	Grease Gun	Weekly
Universal Joint	2	Grease Gun	Monthly
Hydraulic System			
Reservoir	1	Check Daily; Change Annually	
Filter	1	Check Daily; Change when indicator is red	
Conveyor - All Except #5 Conveyor			
Dragshaft Bearings	2	Grease Gun	Weekly
Idler Shaft Bearings	2	Grease Gun	Daily
Idler Adjusting Screws	2	Hand Grease	Weekly
Chain	2 Strands	Spray Oil	Daily
Chain Oiler (If so equipped)	1	Oil Mixture	Daily
Conveyor - #5 Conveyor			
Dragshaft Bearings	2	Grease Gun	Weekly
Idler Shaft Bearings	2	Grease Gun	Weekly
Snubber Pulley Bearings	2	Grease Gun	Weekly
Idler Adjusting Screws	2	Hand Grease	Monthly
Conveyor			
Gear Case	1	Gear Box Oil	Check Monthly, Change Annually
Feedgate Jack Assembly			
Gears	1	Hand Grease	Annually
Tube	1	Grease Gun	Monthly
Spinner			
Grease Zerks – Jack & Shaft	4	Grease Gun	Weekly

NOTE: Unusual conditions, such as excessive dust, temperature extremes or excessive moisture may require more frequent lubrication of specific parts.

* See Lubricant and Hydraulic Oil Specifications for types of lubricants and oil to be used.



Please Give Part No., Description and Unit Serial No. 97373-D

TROUBLESHOOTING

- Symptom:** Spinner motors do not turn when spinner control valve is in running position or conveyor does not run in manual mode. See reasons 1, 2, 3, 4, 5, 7, 8 & 9.
- Symptom:** Spinners turn but conveyor does not run in manual mode. See reasons 6, 8, 9, 10 & 11.
- Symptom:** Console in operation mode, but the conveyor does not move when the machine moves. See reasons 6, 8, 9, 10 & 11.
- Symptom:** Spinner speed does not stay constant. See reasons 4, 5, 12, 13 & 14.
- Symptom:** Spinners run with cab control in “Off” position. See reason 15.
- Symptom:** Hydraulic oil overheats (200° F. or hotter). See reasons 1, 4, 6, 16, 17, 18 & 19.
- Symptom:** Light flashes and buzzer sounds intermittently. Conveyor runs in jerks. See reasons 20, 21, 22 & 27.
- Symptom:** Conveyor does not run with cab control “On”, PTO engaged and vehicle driving forward. See reasons 23, 24 & 25.
- Symptom:** Conveyor runs when control switch in cab is in “Off” position. See reasons 16 & 26.
- Symptom:** Conveyor starts to run when PTO is engaged. See reasons 16, 23, 26 & 27.
- Symptom:** Controller application or programming. Refer to the control manual’s Troubleshooting section.



TROUBLESHOOTING CONTINUED**Reason:****Correction:**

1. Hydraulic oil level low.	Add hydraulic oil as necessary to maintain level around mid-point of sight gauge.
2. Shut-Off valve on oil reservoir not open.	Open valve fully by turning counter-clockwise until it stops.
3. Hydraulic Pump is not rotating.	<ol style="list-style-type: none"> 1. PTO is disengaged. Shift into engagement. 2. Drive line has failed. Repair or replace. 3. Key in pump shaft has failed. Replace key. 4. U-joint pin or key has failed. Replace pin or key.
4. In-line relief valve set too low.	<p>In-line relief valve pressure should be 3100 PSI (213.7 b). Set spinner control valve to "0". Disconnect pressure line, coming from rear port on spinner control valve, at control. Reconnect this line to flow meter inlet port. Disconnect return line from control where it joins the return tube running to the reservoir. Connect flow meter load valve to return tube. Open load valve fully, run truck engine at about 2750 RPM. Slowly close load valve until pressure reaches 3100 PSI (213.7 b). If this pressure cannot be reached, set up relief valve adjustment until gauge reads 3100 PSI (213.7 b).</p> <p>CAUTION: Do not set pressure above 3100 PSI (213.7 b).</p>
5. Worn pump.	With flow meter arranged to check relief valve setting above, open load valve fully. Read flow rate with truck engine running at 2750 RPM. Close load valve until pressure reads 1000 PSI. Flow rate should not decrease more than three (3) GPM. If flow loss is greater, replace pump.
6. Mark Series relief valve open to return line.	Using relief valve testing adapter and flow meter, test valve for opening pressure. If not 2000 PSI (137.9 b), replace relief valve.
7. Jammed or frozen spinner motors.	Free up. If not possible, replace as required.
8. Jammed or frozen conveyor.	Free up conveyor.
9. Jammed or frozen conveyor hydraulic motor.	Replace motor.
10. Conveyor hydraulic motor shaft key sheared.	Replace key.
11. Mark Series control gears stripped or unpinned.	Remove Mark series service hole cover. With hydraulics off, when control is run in manual mode the idler arm should rotate freely. If it doesn't, examine for stripped gears or unpinned gears. Replace as required. Check also for jammed valve spool. If jammed, replace control unit.
12. Pump speed is not adequate to provide sufficient flow to maintain spinner speed.	Increase engine speed.
13. Insufficient hydraulic oil flow at normal driving speeds.	Check PTO-Pump matching. If insufficient flow results, install higher percent PTO or use larger pump (Special).



TROUBLESHOOTING CONTINUED

<u>Reason:</u>	<u>Correction:</u>
14. Defective spinner control valve.	Replace valve metering spool spring. If no improvement, replace spinner control valve.
15. Cab control is for conveyor only—spinners run anytime vehicle engine is running, PTO is engaged and spinner control valve is in a running position.	None required. This is a normal condition. To stop spinners, set spinner control valve at “O” position, disconnect PTO, or shut off vehicle engine.
16. Excessive oil is being pumped.	<ol style="list-style-type: none"> 1. PTO percentage too high. Change PTO to smaller percentage or use smaller pump. 2. Pump is too large. Do not exceed 30 GPM pumping rate. Change to smaller pump or use smaller percentage PTO. 3. Pressure drop in control valve is sufficient to run lightly loaded conveyor motor. Shut off pump drive by disengaging PTO shaft.
17. Worn motor (spinner or conveyor).	Motor heats up at an excessive rate (check for this heating when system is cold). Replace motor.
18. Improper or deteriorated hydraulic oil.	Replace hydraulic oil with proper specification oil and replace filter.
19. Pinched or obstructed hose, hydraulic line or fitting.	Clear obstruction or replace part. Straighten kinked hoses.
20. Driving too fast for application rate.	Shift truck transmission to a lower gear. Will not normally occur if within maximum application rates.
21. Synco-Matic® Mark series cog-belt drive has failed.	Cog-belt is broken or disengaged. Reset or replace. Cog drive pulleys may be unpinned—re-pin to shaft.
22. Synco-Matic® Mark series control gear has failed.	Examine gears for stripping or being disconnected. Replace.
23. Defective radar.	Check speed on console. Repair or replace radar as required.
24. Defective gear train in Mark series valve.	Remove cover from Mark series control valve. Idler arm should rotate around connection gear. If not, replace gear train.
25. Locked spool in Mark series valve.	Check as for defective gear train above. If arm does not rotate, check for stripped gears in gear train. Replace gears if stripped. With new gears, the idler gears will not turn with hand pressure, check for locked valve spool. Replace Mark series valve if spool is jammed.
26. Control processor’s power is in “Off” position.	Turn on control processor.
27. Involves the controller.	Refer to control manual.



STANDARD TORQUES NATIONAL COARSE (NC) CAP SCREWS

CAP SCREW GRADE IDENTIFICATION - MARKINGS ON HEAD

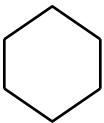
SAE GRADE 2  NO MARKINGS

SAE GRADE 5  THREE MARKS - 120 DEGREES APART

SAE GRADE 8  SIX MARKS - 60 DEGREES APART

USE GRADE 2 TORQUES FOR STAINLESS STEEL FASTENERS AND CARRIAGE BOLTS.

CAP SCREW SIZE	TORQUE - FOOT-POUNDS					
	GRADE 2		GRADE 5		GRADE 8	
	DRY	LUBE	DRY	LUBE	DRY	LUBE
1/4"	5	4	8	6	12	9
5/16"	11	8	17	13	25	18
3/8"	20	15	30	23	45	35
7/16"	30	24	50	35	70	55
1/2"	50	35	75	55	110	80
9/16"	65	50	110	80	150	110
5/8"	90	70	150	110	220	170
3/4"	100	120	260	200	380	280
7/8"	140	110	400	300	600	460
1"	220	160	580	440	900	650



Please Give Part No., Description and Unit Serial No.

97373-D
Page Rev. A

INSTRUCTIONS FOR ORDERING PARTS



Order from the AUTHORIZED DEALER in your area.

1. Always give the pertinent model and serial number of the spreader.
2. Give part name, part number and the quantity required.
3. Give the correct street address to where the parts are to be shipped, and the carrier if there is a preference.

Unless claims for shortages or errors are made immediately upon receipt of goods they will not be considered. Any part returns should be directed through the dealer from which they were purchased.

When broken goods are received, a full description of the damage should be made by the carrier agent on the freight bill. If this description is insisted upon, full damage can always be collected from the transportation company.

No responsibility is assumed for delay or damage to merchandise while in transit. Our responsibility ceases upon delivery of shipment to the transportation company from whom a receipt is received showing that shipment was in good condition when delivered to them. Therefore, claims (if any) should be filed with the transportation company and not with Highway Equipment Company.

If your claims are not being handled (by the transportation company) to your satisfaction, please call the Parts Manager at Highway Equipment Company (319) 363-8281 for assistance.

In the parts list the following symbols and abbreviations stand for:

- * - Not Shown
- AR – As Required
- CS – Carbon Steel
- SS – Stainless Steel

The parts listed under the different steel types (CS and 304 SS) are for that type of unit and do not necessarily mean the part is made of that type of steel.



MOUNTING ANGLE

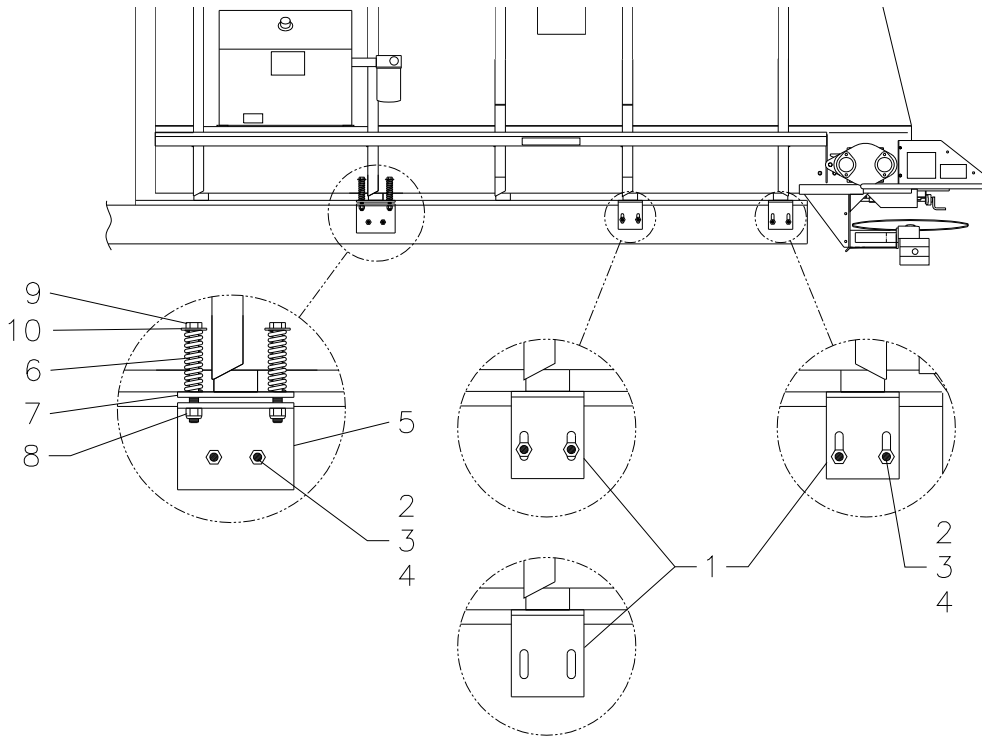

<u>ITEM</u>	<u>PART NO.</u>	<u>DESCRIPTION</u>	<u>QTY</u>
1	31856	Angle – Mounting	4
2	20131	Cap Screw - 1/2 x 2	12
3	20695	Washer – Flat 1/2	12
4	20680	Washer – Flat 1/2	12
5	81847	Angle – Mounting	2
6	81000	Spring	4
7	81848	Mounting – Bar	2
8	41762	Nut – Lock 5/8	4
9	20195	Cap Screw – 5/8 x 6 1/2	4
10	20697	Washer – Flat 5/8	4

FEEDGATE AND JACK

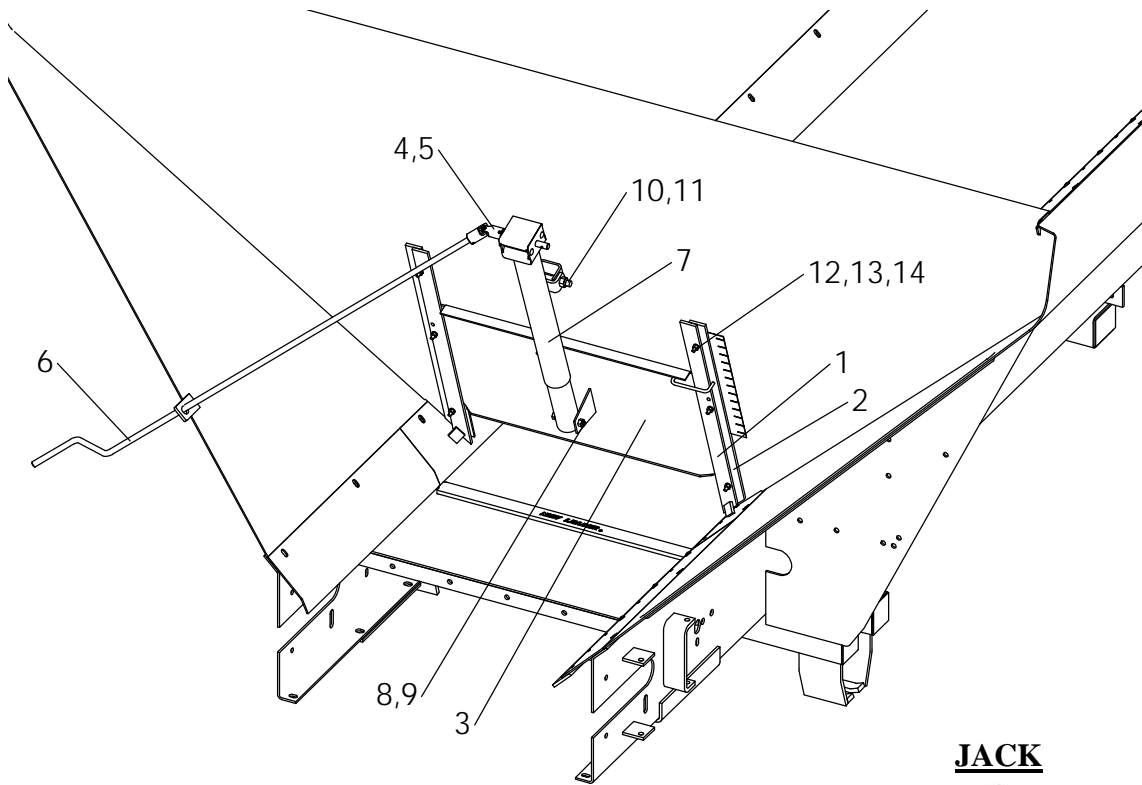

JACK

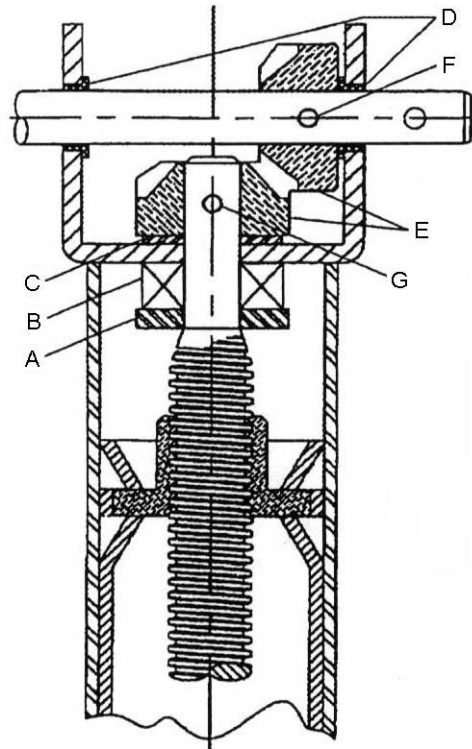

Please Give Part No., Description and Unit Serial No.

97373-D

FEEDGATE AND JACK CONTINUED

<u>ITEM</u>	<u>PART NO.</u>			<u>DESCRIPTION</u>	<u>QTY</u>
	CS	409 SS	304 SS		
1	2885	36384	36384	Slide - Feedgate RH	1
	2884	36384	36384	Slide - Feedgate LH	1
2	NA	36385	36385	Guide - Feedgate	2
3	98508	98509	98510	Feedgate Weldment	1
4	85002	85002	85002	U-Joint	1
5	20918	20918	20918	Pin - Roll	2
6	14382	14382	14382	Handle	1
7	40704	40704	40704	Jack	1
A	84210	84210	84210	Washer - Thrust	1
B	84211	84211	84211	Bearing - Thrust	1
C	84212	84212	84212	Washer	1
D	84213	84213	84213	Bushing	2
E	84214	84214	84214	Gear - Miter	2
F	84215	84215	84215	Pin - Groove	1
G	84216	84216	84216	Pin - Roll	1
8	20074	36296	36296	Cap Screw - 3/8 x 2 3/4	1
9	20678	72054	72054	Nut - Lock 3/8	1
10	20138	80798	80798	Cap Screw - 1/2 x 3 3/4	1
11	20680	39016	39016	Nut - Hex 1/2	1
12	20006	40750	40750	Cap Screw - 1/4 x 1 1/4	6
13	20710	36418	36418	Washer - Lock 1/4	6
14	20642	36412	36412	Nut - Hex 1/4	6
	* 84221	84221	84221	Jack Service Kit, Includes A - G	



Please Give Part No., Description and Unit Serial No.

97373-D

#5 BOTTOM

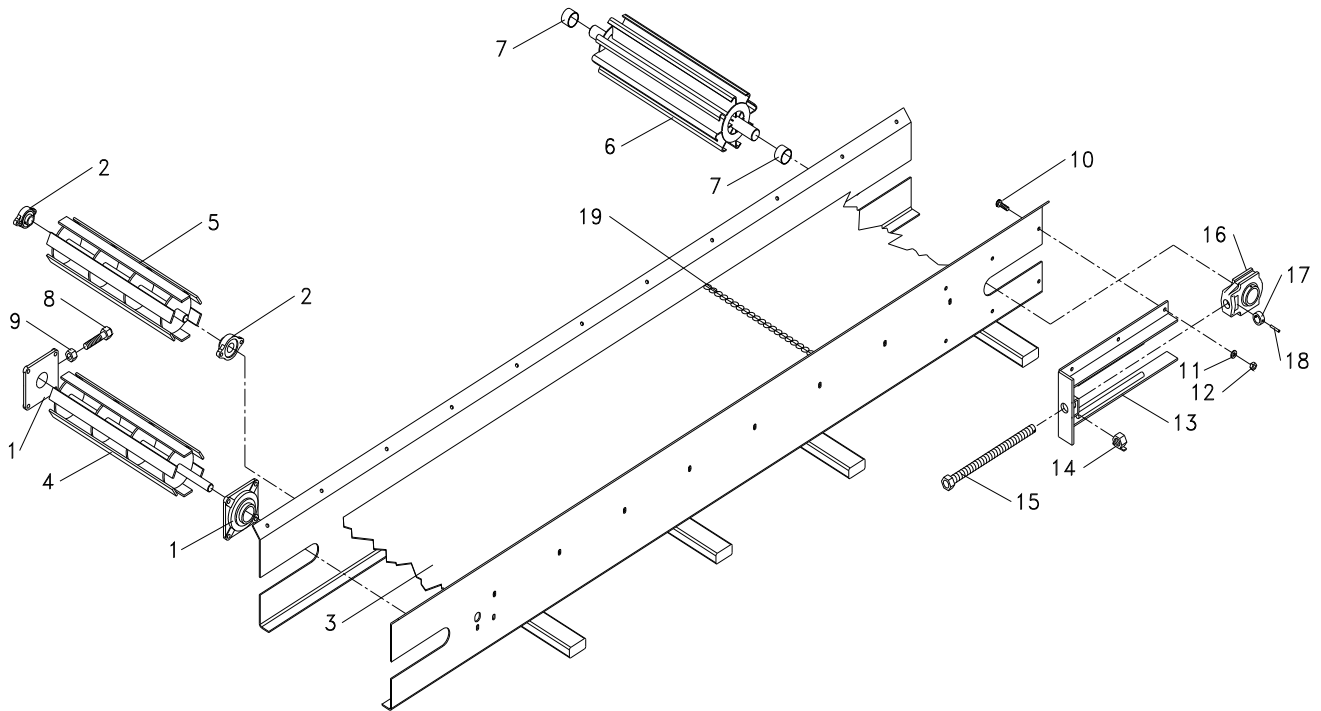

ITEM	PART NO.		DESCRIPTION	QTY
	CS	SS		
	53982	53982	#5 Belt Assembly – 10' Unit	
	53983	53983	#5 Belt Assembly – 11' Unit	
	53984	53984	#5 Belt Assembly – 12' Unit	
	55454	55454	#5 Belt Assembly – 12'6" Unit	
	53985	53985	#5 Belt Assembly – 13' Unit	
NOTE: The above assemblies include Items 3 and 19.				
1	6465	6465	Bearing	2
2	32468	32468	Bearing	2
3	39597	39597	Belt Only 10' Unit	1
	39598	39598	Belt Only 11' Unit	1
	39599	39599	Belt Only 12' Unit	1
			Belt Only 12'6" Unit	
	39600	39600	Belt Only 13' Unit	1
4	39572	43793	Pulley – Drive, Use with Single Pinion	1
	54736	54737	Pulley – Drive, Use with Dual Pinion	1
5	33875	36366	Pulley - Snub	1
6	81343	81344	Pulley - Idler	1
7	81345	81345	Spacer - Pipe	2
8	81354	81354	Screw - Set, 3"	1
9	36417	36417	Nut - Hex, 5/8	1



Please Give Part No., Description and Unit Serial No.

97373-D

#5 BOTTOM CONTINUED

<u>ITEM</u>	<u>PART NO.</u>		<u>DESCRIPTION</u>	<u>QTY</u>
	CS	SS		
10	20319	36409	Bolt – Carriage 3/8 x 1 1/4	12
11	20712	36420	Washer – Lock 3/8	12
12	20644	36414	Nut – Hex 3/8	12
	36507	36507	Take-up Assembly, Includes Items 13–18	2
13	7895	7895	Bracket – Take-up Weldment	2
14	39110	39110	Nut Weldment	2
15	36508	36508	Chain Tightener Weldment	2
16	22511	22511	Bearing – Take-up	2
17	30725	30725	Collar – Set	2
18	20925	20925	Pin – Roll	2
19	53995	53995	Kit – Belt Splicing, Consisting of:	1
	53992	53992	Fastener - Hinge 1 Bolt	4
	53993	53993	Fastener - Hinge 2 Bolt	2
	53994	53994	Fastener - Hinge 3 Bolt	4
	33884-23	33884-23	Tape - Belt Stiffener	2
	39603	39603	Pin - Hinge	1
	39604-23	39604-23	Tube - Sealer	2



Please Give Part No., Description and Unit Serial No.

CONVEYOR IDLER

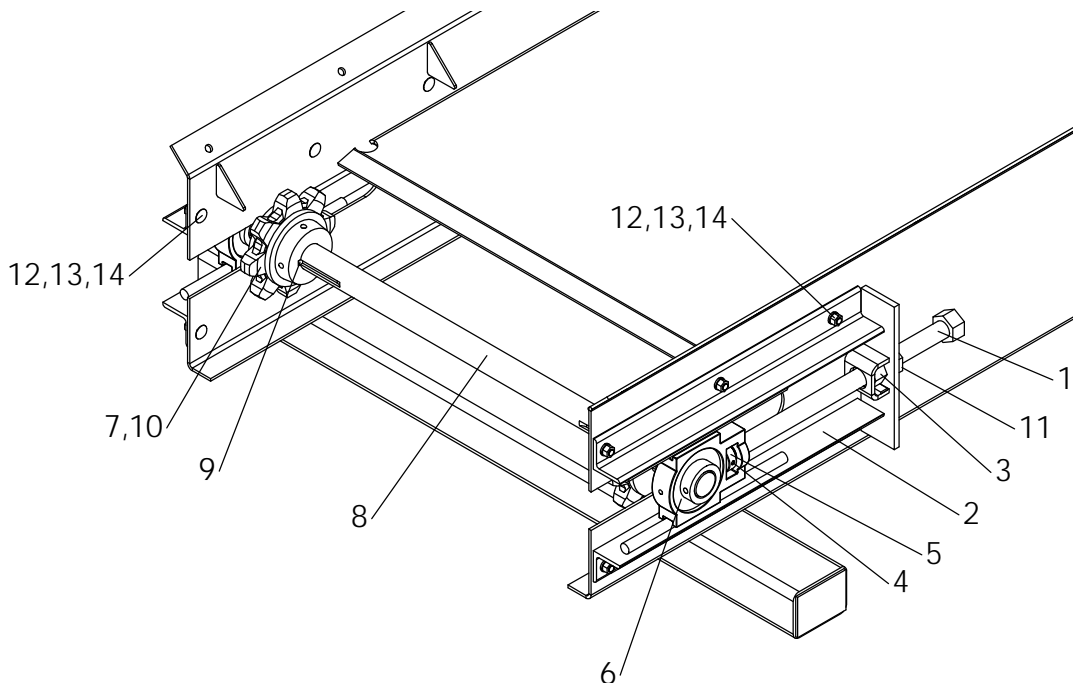

<u>ITEM</u>	<u>PART NO.</u>		<u>DESCRIPTION</u>	<u>QTY</u>
	CS	SS		
1	36508	36508	Chain Tightener Weldment	2
2	7895	7895	Take-up Weldment	2
3	39110	39110	Nut Weldment	2
4	20925	20925	Pin – Roll 1/4 x 1 1/2	2
5	30725	30725	Collar – Set 1”	2
6	22511	22511	Bearing – Take-up	2
7	97051	97051	Sprocket – Idler	2
8	48279	48279	Shaft – Idler	1
9	2135	2135	Key – Square	2
10	20743	20743	Screw – Set 5/16 x 3/8	4
11	36509	36509	Nut – Hex 1-8NC	2
12	20318	36408	Bolt – Carriage 3/8 x 1	12
13	20712	36420	Washer – Lock 3/8	12
14	20644	36414	Nut – Hex 3/8	12

CONVEYOR DRIVE

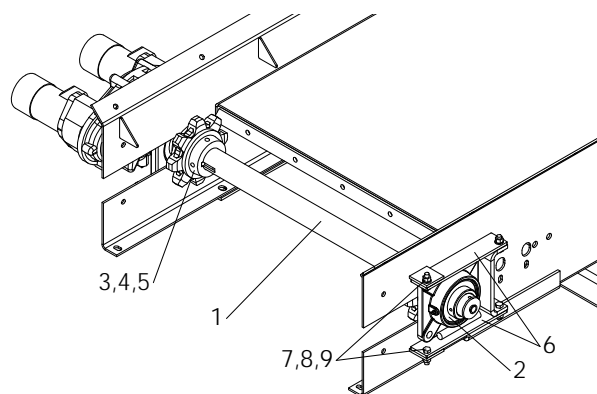
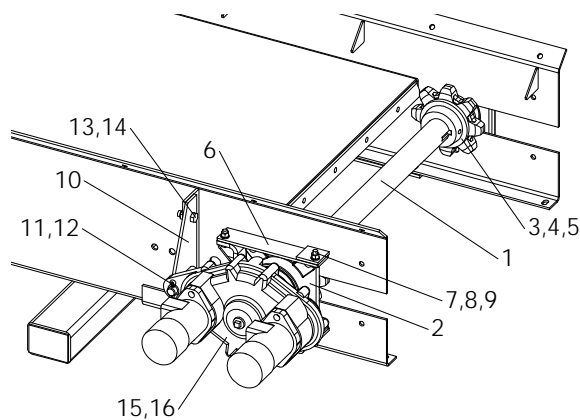

<u>ITEM</u>	<u>PART NO.</u>		<u>DESCRIPTION</u>	<u>QTY</u>
	CS	SS		
1	77899	77899	Shaft – Drive Single Pinion	1
	98090	98090	Shaft – Drive Dual Pinion	1
2	6465	6465	Bearing	2
3	88276	88276	Sprocket	2
4	20743	20743	Screw – Set 5/16 x 3/8	4
5	6131	6131	Key – Square 1/2 x 1 1/2	2
6	82882	82885	Guide – Bearing	4
7	20068	36399	Cap Screw - 3/8 x 1 1/4	8
8	20712	36420	Washer – Lock 3/8	8
9	20644	36414	Nut – Hex 3/8	8
10	82550	82552	Bracket - Torque Arm LH	1
11	20833	20833	Pin – Cotter 1/4 x 1 1/2	1
12	2716	2716	Washer – Flat 3/4	2
13	20128	20128	Cap Screw - 1/2 x 1 1/4	2
14	20680	20680	Nut – Lock 1/2	2
15	37010	37010	Key – Square 1/2 x 1 1/2	2
16			Gear Case Assembly – Refer to “Control Hydraulics”	

ENCODER

#2, #3 and #4 Conveyors

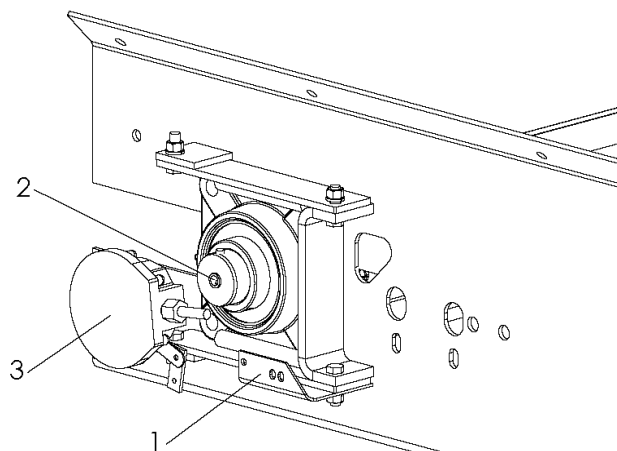

#5 Conveyors

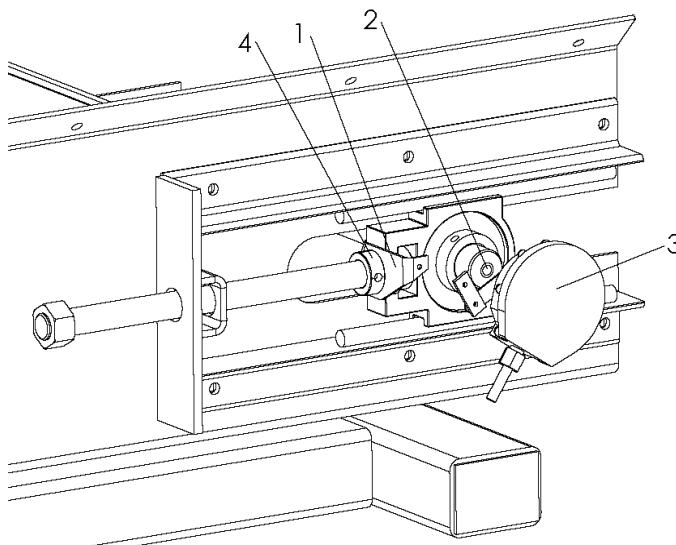

<u>ITEM</u>	<u>PART NO.</u>	<u>DESCRIPTION</u>	<u>QTY</u>
	97341	Mount – Kit Encoder for #2, 3 & 4, Includes 1-3	
	304787	Mount – Kit Encoder for #5, Includes 1-4	
1	304946	Bracket – Rear Shaft	1
	81949	Bracket – Front Shaft	1
2	56263	Sleeve – Rate Sensor	1
3	303994	Encoder – 180 DJ with Hardware	1
	304056	Encoder – 360 DJ with Hardware	1
4	2696	Collar – Set 1”	1



Please Give Part No., Description and Unit Serial No.

THIS PAGE INTENTIONALLY LEFT BLANK



Please Give Part No., Description and Unit Serial No.

CONVEYOR CHAIN OILER

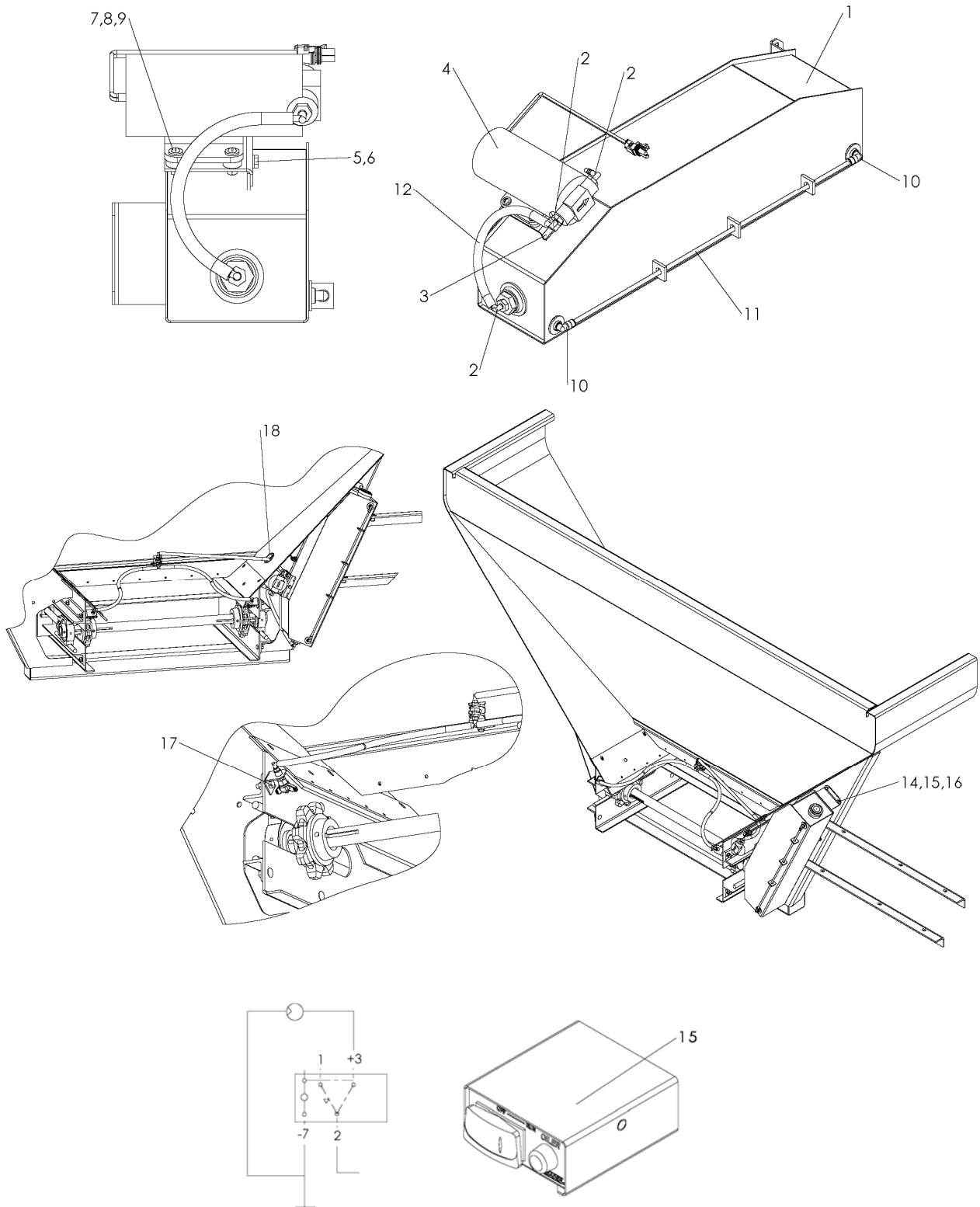

Please Give Part No., Description and Unit Serial No.

97373-D

CONVEYOR CHAIN OILER CONTINUED

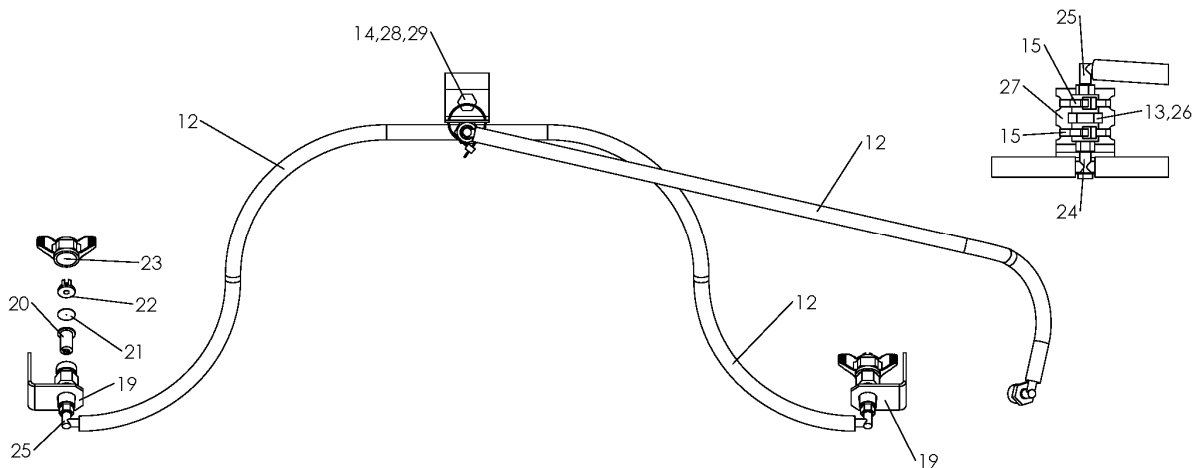

<u>ITEM</u>	<u>PART NO.</u>	<u>DESCRIPTION</u>	<u>QTY</u>
	306063	Tank – Assembly, Includes 1-13	
1	304398	Tank – Weldment	1
2	306657	Elbow	3
3	304409	Mount – Pump	1
4	304390	Pump – Assembly with Connector	1
	304834	Pump – Diagram 1.1 GPM 30 PSI	1
	303730-AB	Connector – FEM Socket Sealed	1
	303730-CC	Terminal – FEM Sealed (Sleeve)	2
	303730-EB	Seal – Cable Lt Gray	2
5	36393	Capscrew – 1/4 x 3/4 SS	5
6	36418	Washer – Lock 1/4 SS	5
7	20574	Screw – Round Head #10 x 1	4
8	171052	Washer – Flat #10 SS	8
9	47295	Nut – Hex #10 SS	4
10	301337	Fitting – 90 Male 1/8 NPT	2
11	306437	Tubing – Clear	Feet 2.063
12	26544	Hose – Low Pressure 1/4 ID x 8	Feet 1.167
13	*306670	Tape – Thread Seal w/PTFE Yellow Gas Line	AR
14	36414	Nut – Hex 3/8 SS	1
15	304391	Panel – Assembly Oiler Control	1
	99676	Fuse – 10AMP Fast Acting	1
16	36412	Nut – Hex 1/4 SS	4



Please Give Part No., Description and Unit Serial No.

97373-D

CONVEYOR CHAIN OILER CONTINUED

<u>ITEM</u>	<u>PART NO.</u>	<u>DESCRIPTION</u>	<u>QTY</u>
17	36399	Capscrew – 3/8 x 1-1/4 SS	2
18	34129	Grommet – Rubber	1
19	306649	Nozzle – Mount Assembly	2
	304839	Angle – Weldment Nozzle Mount	1
	306650	Body – Male Nozzle Brass	1
20	306651	Strainer – Check Valve	2
21	306652	Plate – Orifice SS	2
22	306654	Nozzle – Even Flat Spray SS	2
23	306653	Cap – Nozzle	2
24	306655	Tee – Black	1
25	306656	Elbow – Black	3
26	306678	Coupling – Polypropylene	1
27	306804	Bracket – Coupling	1
28	36293	Capscrew – 3/8 x 3/4 SS	1
29	36420	Washer – Lock 3/8 SS	1

AR – As Required



Please Give Part No., Description and Unit Serial No.

97373-D

THIS PAGE INTENTIONALLY LEFT BLANK.



Please Give Part No., Description and Unit Serial No.

PINTLE CHAIN CONVEYOR

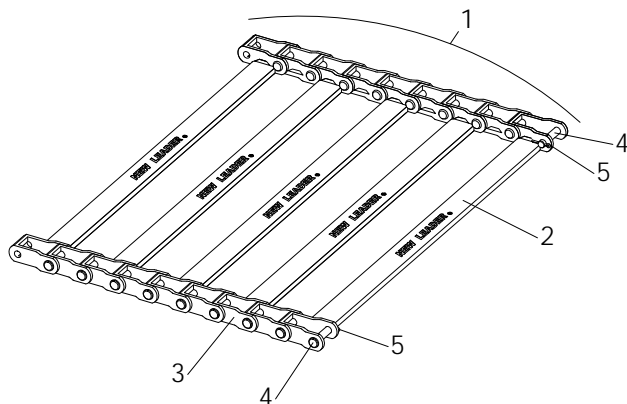

#2 – Cross bars every other link

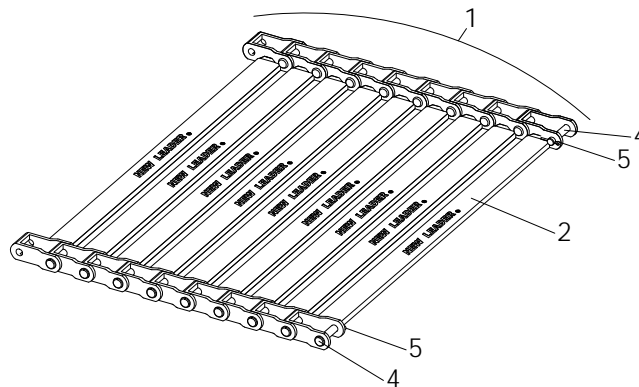

#3 – Cross bars every link

<u>ITEM</u>	<u>PART NO.</u>		<u>DESCRIPTION</u>	<u>QTY</u>
	#2	#3	Chain – Assembly	
1	81869	81884	10' Unit	1
	81870	81885	11' Unit	1
	81871	81886	12' Unit	1
	81872	81887	12'6" Unit	1
	81873	81888	13' Unit	1
	81874	81889	14' Unit	1
	81875	81890	15' Unit	1
	81876	81891	16' Unit	1
2	36699	36699	Link – Pintle Chain	AR
3			Crossbar Weldment	AR
4	36697	36697	Pin – Pintle Chain	AR
5	20817	20817	Pin – Cotter	AR



Please Give Part No., Description and Unit Serial No.

97373-D

CONVEYOR CHAIN

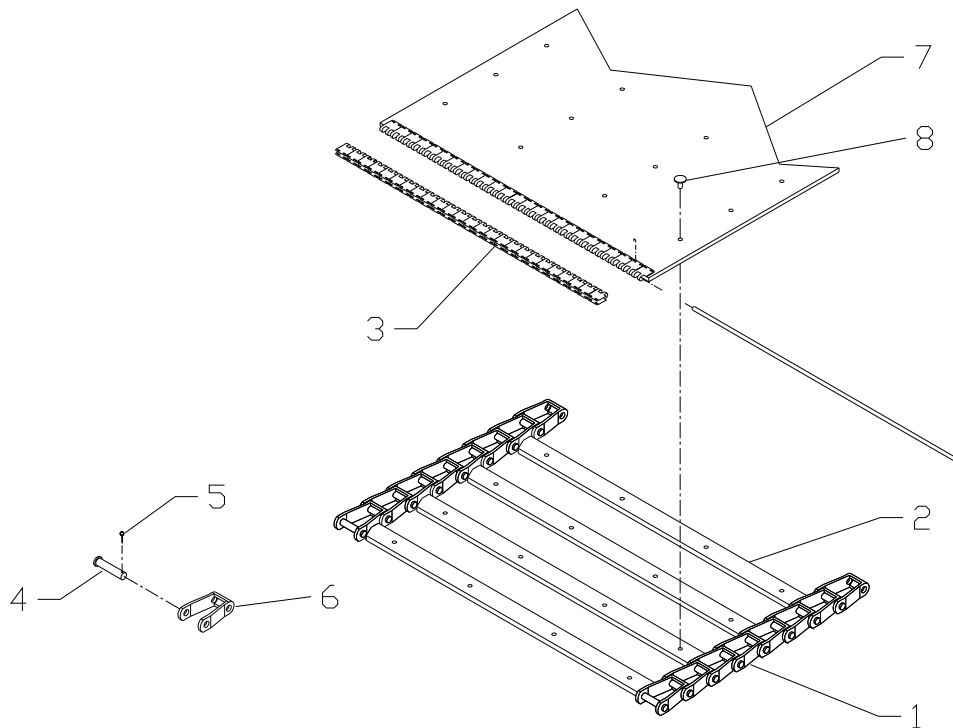

<u>ITEM</u>	<u>PART NO.</u>	<u>PART NO.</u>	<u>DESCRIPTION</u>	<u>QTY</u>
1	#4 BOC -----	#5 BOC 305307-AA	Chain – Conveyor Assembly 8’ Unit	1
	305613-AC	305307-AC	10’ Unit	1
	305613-AD	305307-AD	11’ Unit	1
	305613-AE	305307-AE	12’ Unit	1
	305613-AF	305307-AF	12’6” Unit	1
	305613-AG	305307-AG	13’ Unit	1
	305613-AH	-----	14’ Unit	1
	305613-AI	-----	15’ Unit	1
	305613-AJ	-----	16’ Unit	1
2	81403		Crossbar – Weldment w/Rivet Holes	AR
3	73317-X1		Kit – Splicer	1
			Lacing Strips 23”	2
			Pin - Connecting	1
			Staples	AR
4	36697		Pin – Pintle Chain	AR
5	20817		Pin – Cotter	AR
6	36699		Link – Pintle Chain	AR
7	6251		Belt – Conveyor (Specify Unit Length)	AR
8	6245		Rivet	AR



Please Give Part No., Description and Unit Serial No.

97373-D

CHAIN SHIELDS

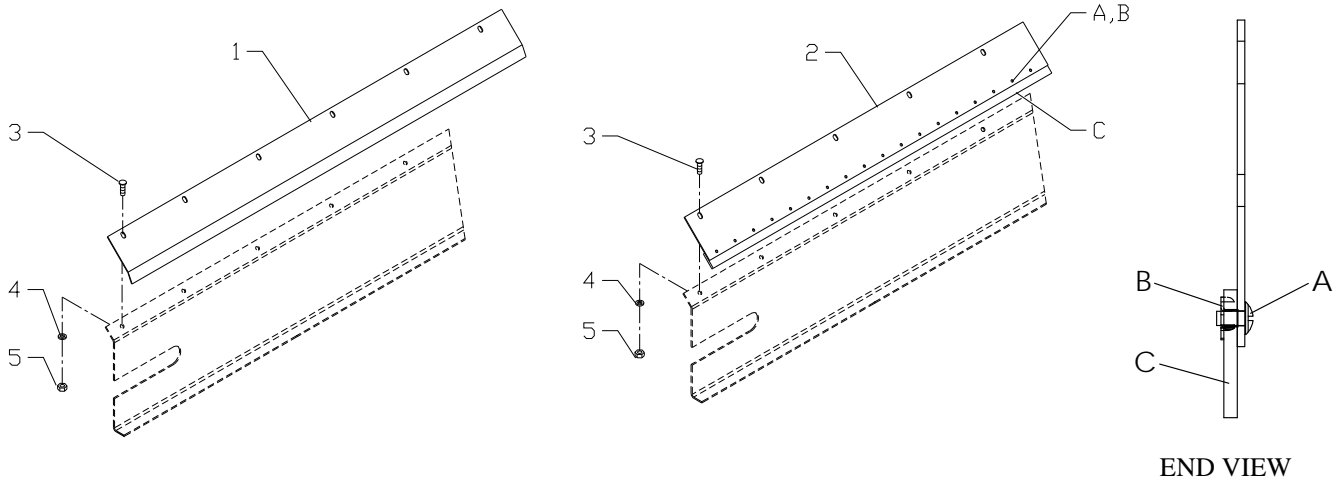

<u>ITEM</u>	<u>PART NO.</u>			<u>DESCRIPTION</u>	<u>QTY</u>
	CS	409 SS	304 SS		
				Chain Shield – RH #2 & #3 Chain	
1	97713-AC	97730-AC	97747-AC	10' Unit	1
	97713-AD	97730-AD	97747-AD	11' Unit	1
	97715-AA	97732-AA	97749-AA	12' Unit	1
	97714	97716	97720	12'6" Unit	1
	97715-AB	97732-AB	97749-AB	13' Unit	1
	97715-AC	97732-AC	97749-AC	14' Unit	1
	97715-AD	97732-AD	97749-AD	15' Unit	1
	97715-AE	97732-AE	97749-AE	16' Unit	1
				Chain Shield – LH #2 & #3 Chain	
	97713-AG	97730-AG	97747-AG	10' Unit	1
	97713-AH	97730-AH	97747-AH	11' Unit	1
	97715-AF	97732-AF	97749-AF	12' Unit	1
	97731	97733	97737	12'6" Unit	1
	97715-AG	97732-AG	97749-AG	13' Unit	1
	97715-AH	97732-AH	97749-AH	14' Unit	1
	97715-AI	97732-AI	97749-AI	15' Unit	1
	97715-AJ	97732-AJ	97749-AJ	16' Unit	1



Please Give Part No., Description and Unit Serial No.

97373-D

CHAIN SHIELDS CONTINUED

<u>ITEM</u>	<u>PART NO.</u>			<u>DESCRIPTION</u>	<u>QTY</u>
	CS	409 SS	304 SS		
2				Chain Shield – RH #4 BOC	
	97815	97833	97851	10' Unit	1
	97816	97834	97852	11' Unit	1
	97817	97835	97853	12' Unit	1
	97873	97874	97875	12'6" Unit	1
	97818	97836	97854	13' Unit	1
	97819	97837	97855	14' Unit	1
	97820	97838	97856	15' Unit	1
	97821	97839	97857	16' Unit	1
				Chain Shield – LH #4 BOC	
	97824	97842	97860	10' Unit	1
	97825	97843	97861	11' Unit	1
	97826	97844	97862	12' Unit	1
	97876	97877	97878	12'6" Unit	1
	97827	97845	97863	13' Unit	1
	97828	97846	97864	14' Unit	1
	97829	97847	97865	15' Unit	1
	97830	97848	97866	16' Unit	1
A	20624	56258	56258	Screw – Truss Head 1/4 x 1/2	AR
B	88931	88931	88931	Nut – Tee 1/4 x 1/4	AR
C	7687	7687	7687	Sealer - Belt, #4 BOC Shield (Specify Unit Length)	AR
3	20318	71829	71829	Bolt – Carriage 3/8 x 1	AR
4	20712	36420	36420	Washer – Lock 3/8	AR
5	20644	36414	36414	Nut – Hex 3/8	AR



Please Give Part No., Description and Unit Serial No.

97373-D

FRONT WIPER

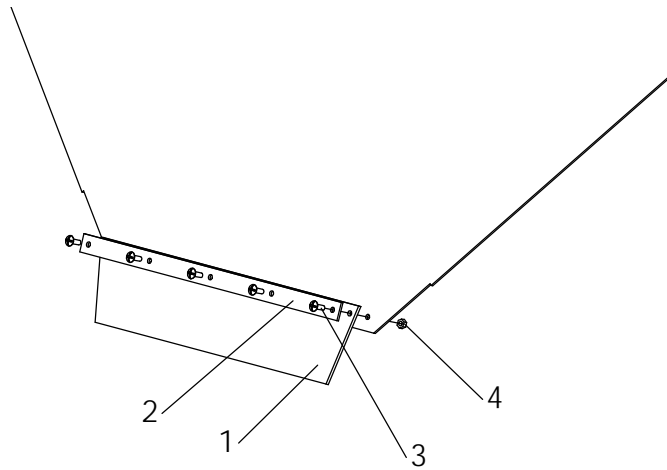

<u>ITEM</u>		<u>PART NO.</u>		<u>DESCRIPTION</u>	<u>QTY</u>
	CS	409	304		
1	39426	39426	39426	Belt – Front Wiper	1
2	39408	43605	54230	Retainer – Front Wiper Belt	1
3	20583	32466	32446	Screw – Truss 1/4 x 3/4	5
4	20642	36412	36412	Nut – Hex 1/4	5



Please Give Part No., Description and Unit Serial No.

REAR WIPER - #2 & #3 CONVEYORS

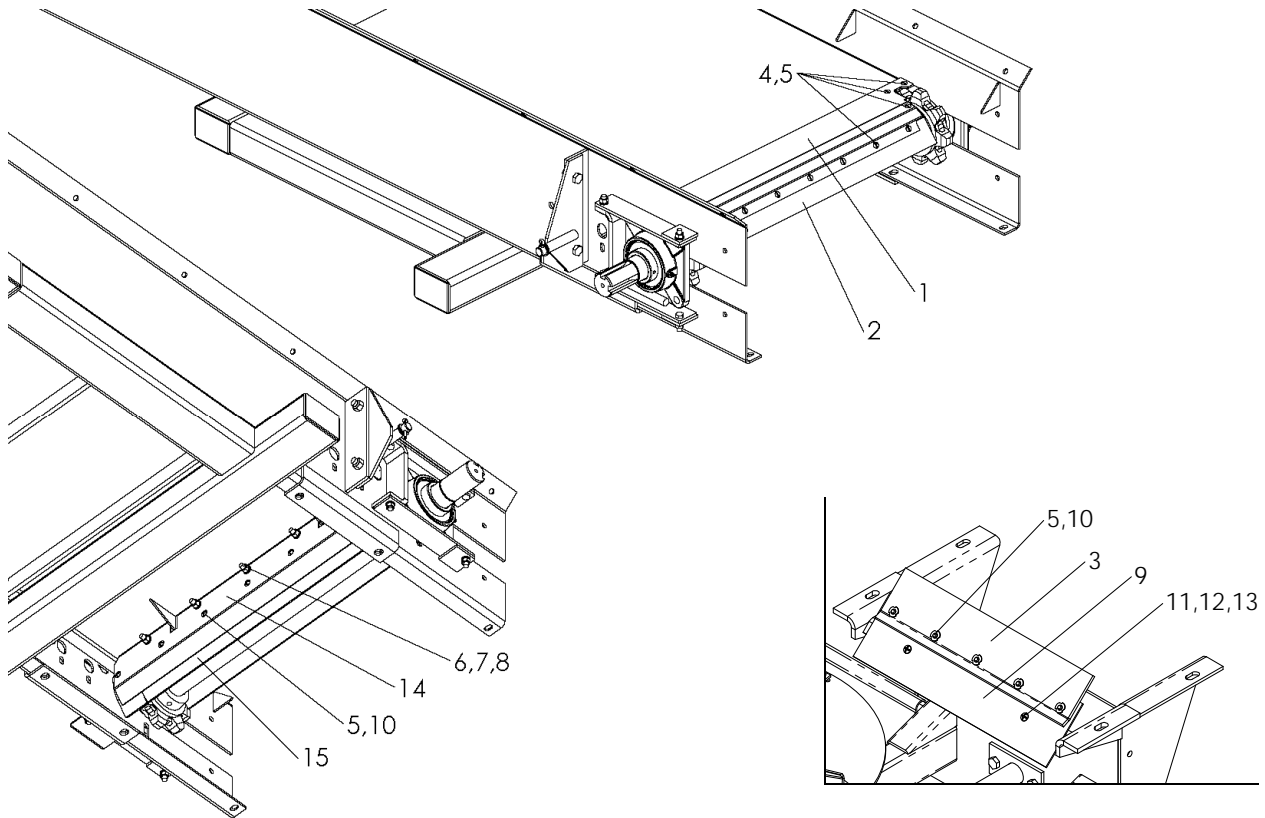

<u>ITEM</u>	<u>PART NO.</u>		<u>DESCRIPTION</u>	<u>QTY</u>
	CS	SS		
	98083	98084	Lip – Group Rear	
	96741	96741	Wiper – Assembly Rear	
1	98049	98050	Lip – Weldment Rear	1
2	305287	305287	Wiper – 30” Rear Lip	2
3	304417	304417	Belt – Rear Wiper	2
4	20617	56400	Screw – Flat Head 1/4 x 1/2	11
5	88931	88931	Nut – Tee 1/4	23
9	20068	36399	Cap Screw – 3/8 x 1	5
7	20712	36420	Washer – Lock 3/8	5
8	20644	36414	Nut – Hex 3/8	5
9	96743	96743	Plate – Wiper Belt	1
10	56258	56258	Screw – Truss Head 1/4 x 1/2	12
11	32446	32446	Screw – Truss Head 1/4 x 3/4	2
12	36418	36418	Washer – Lock 1/4	2
13	36412	36412	Nut – Hex 1/4	2
14	305282	305283	Mount – 24” Internal Wiper	1
15	305284	305284	Rubber – 24” Internal Wiper	1



Please Give Part No., Description and Unit Serial No.

97373-D

FENDERS & MUDFLAPS – TRUCK & SEMI-FLOAT TIRES

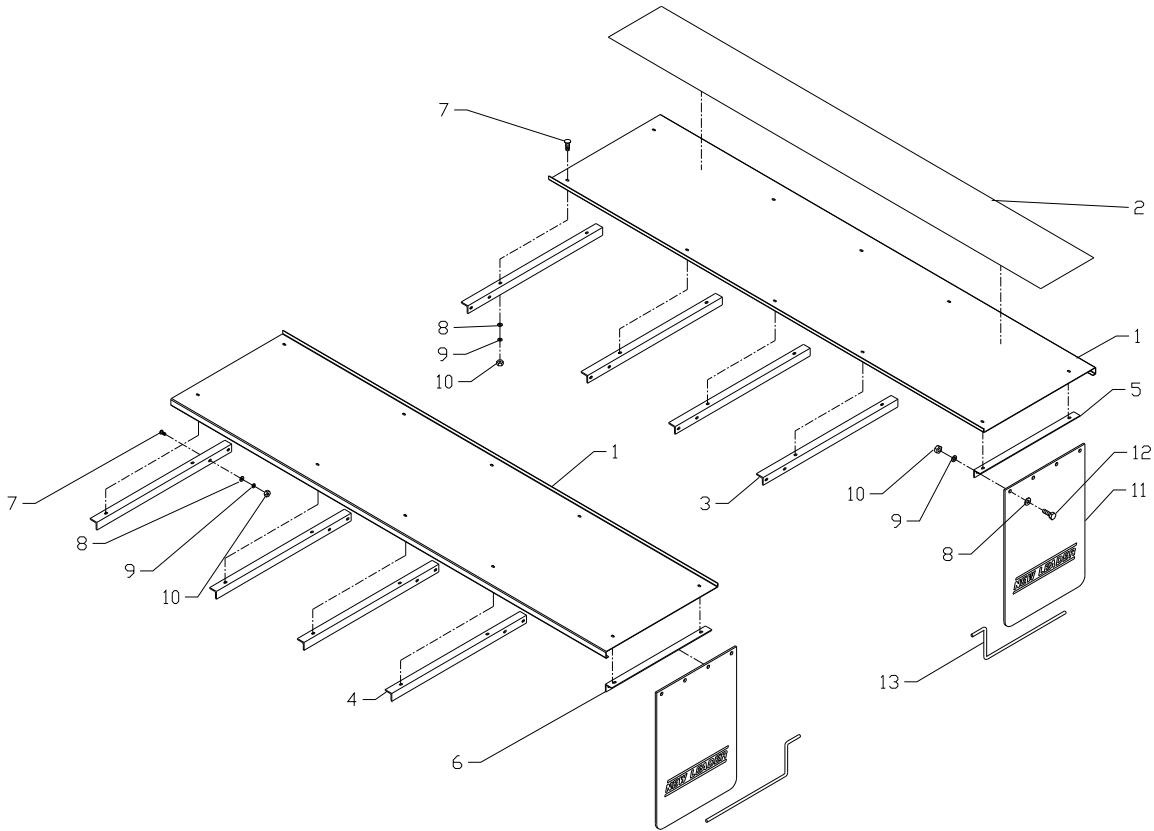

<u>ITEM</u>	<u>PART NO.</u>			<u>DESCRIPTION</u>	<u>QTY</u>
1	CS	409 SS	304 SS	Fender – Truck Tires for:	
	81416	81441	81464	10' Unit	2
	81417	81442	81465	11' Unit	2
	81418	81443	81466	12' Unit	2
	81419	81444	81467	13' Unit	2
	81420	81445	81468	14' Unit	2
	81421	81446	81469	15' Unit	2
	81422	81447	81470	16' Unit	2
				Fender – Semi-Float Tires for:	
	81487	81512	81535	10' Unit	2
	81488	81513	81536	11' Unit	2
	81489	81514	81537	12' Unit	2
	81490	81515	81538	13' Unit	2
	81491	81516	81539	14' Unit	2
	81492	81517	81540	15' Unit	2
	81493	81518	81541	16' Unit	2



Please Give Part No., Description and Unit Serial No.

97373-D
Page Rev. A

FENDERS & MUDFLAPS – TRUCK & SEMI-FLOAT TIRES CONTINUED

<u>ITEM</u>	<u>PART NO.</u>			<u>DESCRIPTION</u>	<u>QTY</u>
	CS	409 SS	304 SS		
2	83124	83124	83124	Material - Non-skid Inches	AR
3	46445	46445	46445	Angle – Mounting	AR
	81428	81428	81428	Angle – Mounting Long	AR
	83021	83021	83021	Angle – Mounting for Semi	AR
	81499	81499	81499	Angle – Mounting Long for Semi	AR
5	46434	71900	71872	Bracket – Mudflap RH	1
	71930	71990	71960	Bracket – Mudflap RH for Semi	1
6	46435	71901	71873	Bracket – Mudflap LH	1
	71931	71991	71961	Bracket – Mudflap LH for Semi	1
7	20318	36408	36408	Bolt - Carriage, 3/8 x 1	AR
8	20693	36425	36425	Washer - Flat, 3/8	AR
9	20712	36420	36420	Washer - Lock	AR
10	20644	36414	36414	Nut - Hex, 3/8	AR
11	7793	7793	7793	Mudflap - NEW LEADER, Truck only	2
12	20067	36398	36398	Cap Screw - 3/8 x 1	12
13	36844	36844	36844	Rod - Mudflap	AR



Please Give Part No., Description and Unit Serial No.

FENDERS – FULL & SUPER FLOATATION TIRES

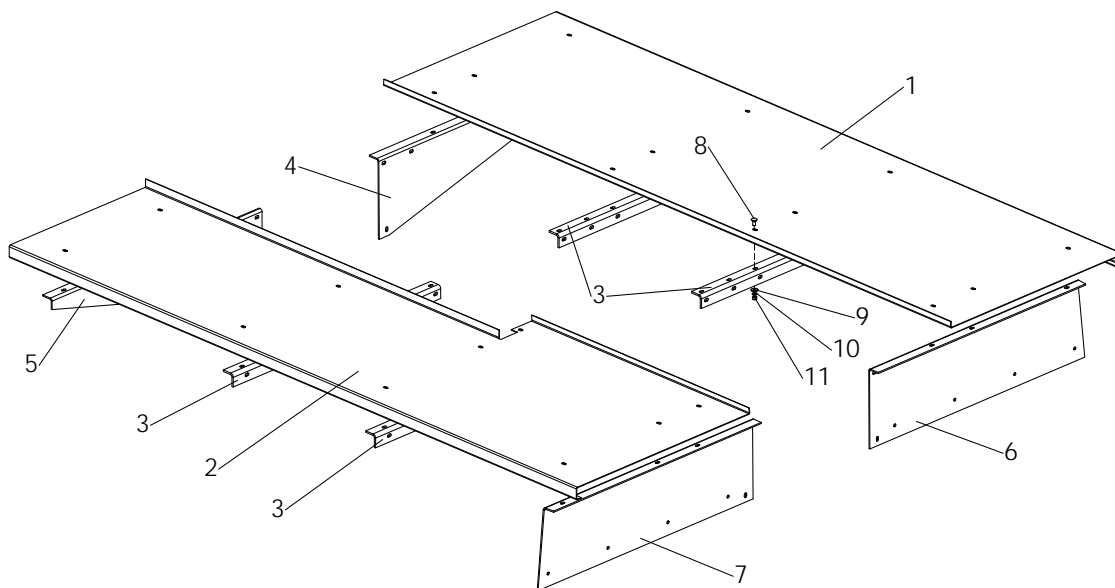

<u>ITEM</u>	<u>PART NO.</u>			<u>DESCRIPTION</u>	<u>QTY</u>
	CS	409 SS	304 SS		
1				Fender - RH, Full for:	
	81554	81582	81606	10' Unit	1
	81555	81583	81607	11' Unit	1
	81556	81584	81608	12' Unit	1
	81557	81585	81609	13' Unit	1
	81558	81586	81610	14' Unit	1
	81559	81587	81611	15' Unit	1
	81560	81588	81612	16' Unit	1
				Fender - RH, Super for:	
	87239	87237	81606-X1	10' Unit	1
	81555-X2	81583-X1	81607-X1	11' Unit	1
	81556-X2	81584-X1	81608-X1	12' Unit	1
	81557-X1	81585-X1	81609-X1	13' Unit	1
	81558-X1	87243	87241	14' Unit	1
	87245	87247	87249	15' Unit	1
	87251	87253	87255	16' Unit	1



Please Give Part No., Description and Unit Serial No.

97373-D

FENDERS – FULL & SUPER FLOATATION TIRES CONTINUED

<u>ITEM</u>	<u>PART NO.</u>			<u>DESCRIPTION</u>	<u>QTY</u>
	CS	409 SS	304 SS		
2				Fender - LH, Full for:	
	81697	81720	81742	10' Unit	1
	81698	81721	81743	11' Unit	1
	81699	81722	81744	12' Unit	1
	81700	81723	81745	13' Unit	1
	81701	81724	81746	14' Unit	1
	81702	81725	81747	15' Unit	1
	81703	81726	81748	16' Unit	1
				Fender - LH, Super for:	
	87240	87238	81742-X1	10' Unit	1
	81698-X2	81721-X1	81743-X1	11' Unit	1
	81699-X2	81722-X1	81744-X1	12' Unit	1
	81700-X1	81723-X1	81745-X1	13' Unit	1
	81701-X1	87244	87242	14' Unit	1
	87246	87248	87250	15' Unit	1
	87252	87254	87256	16' Unit	1
3	81569	81569	81569	Angle – Mounting for Full	AR
	81569-X1	81569-X1	81569-X1	Angle – Mounting for Super	AR
4	83252-X1	83252-X1	83252-X1	Support – Front RH for Super only	1
5	83253-X1	83253-X1	83253-X1	Support – Front LH for Super only	1
6	81573	81597	81621	Support – Rear RH for Full	1
	83254-X1	83254-X1	83254-X1	Support – Rear RH for Super	1
7	81574	81598	81622	Support – Rear LH for Full	1
	83255-X1	83255-X1	83255-X1	Support – Rear LH for Super	1
8	20318	36408	36408	Bolt - Carriage, 3/8 x 1	AR
9	20693	36425	36425	Washer - Flat, 3/8	AR
10	20712	36420	36420	Washer - Lock	AR
11	20644	36414	36414	Nut - Hex, 3/8	AR



Please Give Part No., Description and Unit Serial No.

INVERTED "V"

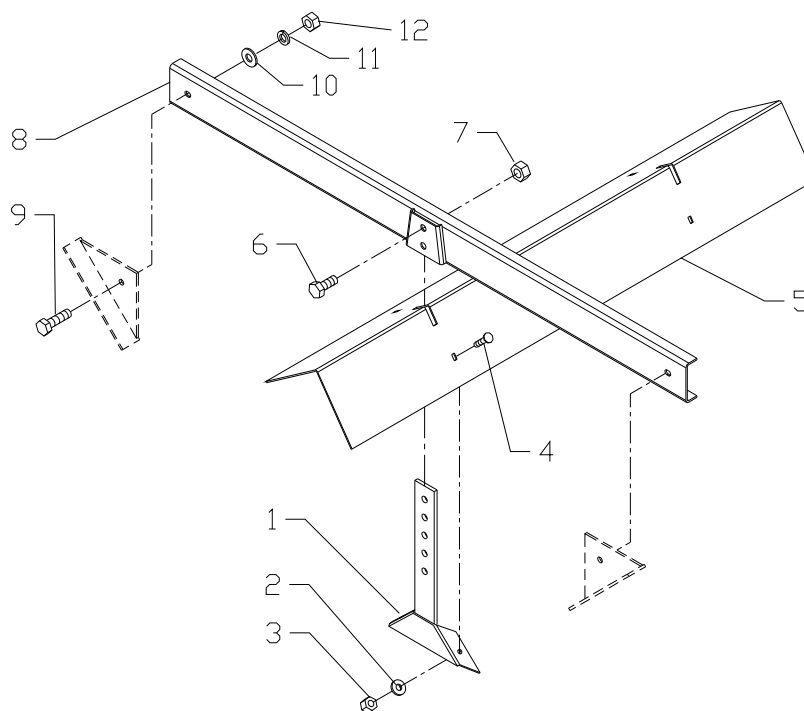

<u>ITEM</u>	<u>PART NO.</u>			<u>DESCRIPTION</u>	<u>QTY</u>
	CS	409 SS	304 SS		
1	82625	82626	82626	Bar - Adjusting. Weldment	AR
2	20692	36424	36424	Washer - Flat, 5/16	AR
3	20677	42221	42221	Nut - Hex, 5/16 Lock	AR
4	20291	42639	42639	Bolt - Carriage, 5/16 x 1	AR
5	82613	82617	82621	Inverted "V" (10' Unit)	1
	82614	82618	82622	Inverted "V" (11' - 12'6" Units)	1
	82615	82619	82623	Inverted "V" (13' - 14' Units)	1
	82616	82620	82624	Inverted "V" (15' - 16' Unit)	1
6	20176	58800	58800	Screw - Cap	AR
7	20682	41762	41762	Nut - Hex, Locking 5/8	AR
8	81261	81262	81263	Hanger Weldment	AR
9	20128	36402	36402	Cap Screw - 1/2 x 1 1/4	AR
10	20695	36426	36426	Washer - Flat, 1/2	AR
11	20714	36422	36422	Washer - Lock, 1/2	AR
12	20646	36416	36416	Nut - Hex, 1/2	AR

CAB SHIELD

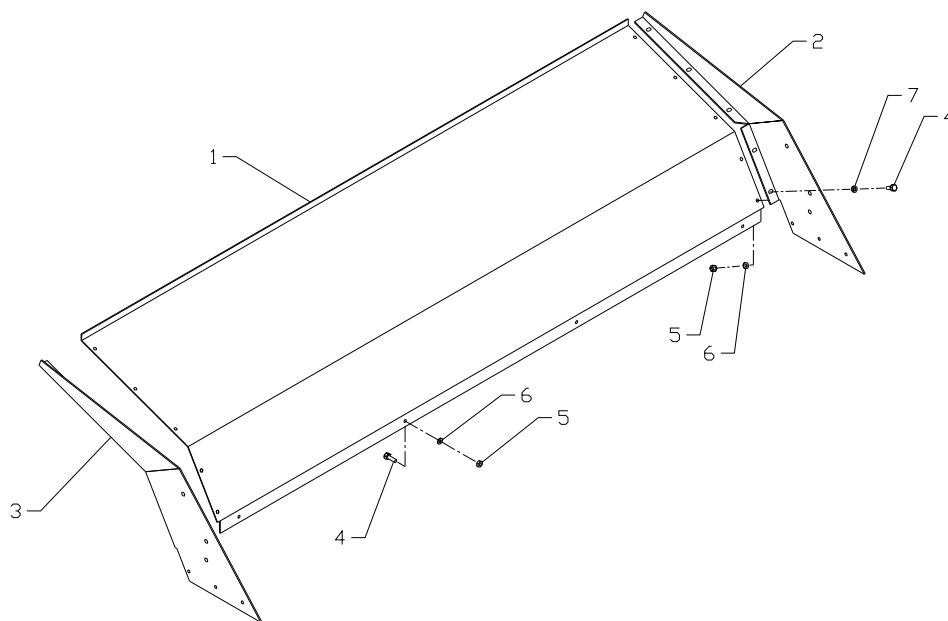

<u>ITEM</u>	<u>PART NO.</u>			<u>DESCRIPTION</u>	<u>QTY</u>
	CS	409 SS	304 SS		
	81910	81912	81911	Cab Shield Assembly - 57" Height	1
	81913	81915	81914	Cab Shield Assembly - 63" Height	1
	81916	81918	81917	Cab Shield Assembly - 69" Height	1
1	81901	81903	81902	Panel - Shield, 57" Height	1
	81904	81906	81905	Panel - Shield, 63" Height	1
	81907	91909	81908	Panel - Shield, 69" Height	1
2	31788	79167	79166	Support Weldment - R.H. 57" Height	1
	39813	79170	79171	Support Weldment - R.H. 63" Height	1
	39819	79175	79174	Support Weldment - R.H. 69" Height	1
3	31789	79169	79168	Support Weldment - L.H. 57" Height	1
	39815	79173	79172	Support Weldment - L.H. 63" Height	1
	39821	79177	79176	Support Weldment - L.H. 69" Height	1
4	20067	36398	36398	Cap Screw - 3/8 x 1	AR
5	20644	36414	36414	Nut - Hex, 3/8	AR
6	20712	36420	36420	Washer - Lock, 3/8	AR
7	20693	36425	36425	Washer - Flat, 3/8	AR



Please Give Part No., Description and Unit Serial No.

97373-D

LADDER

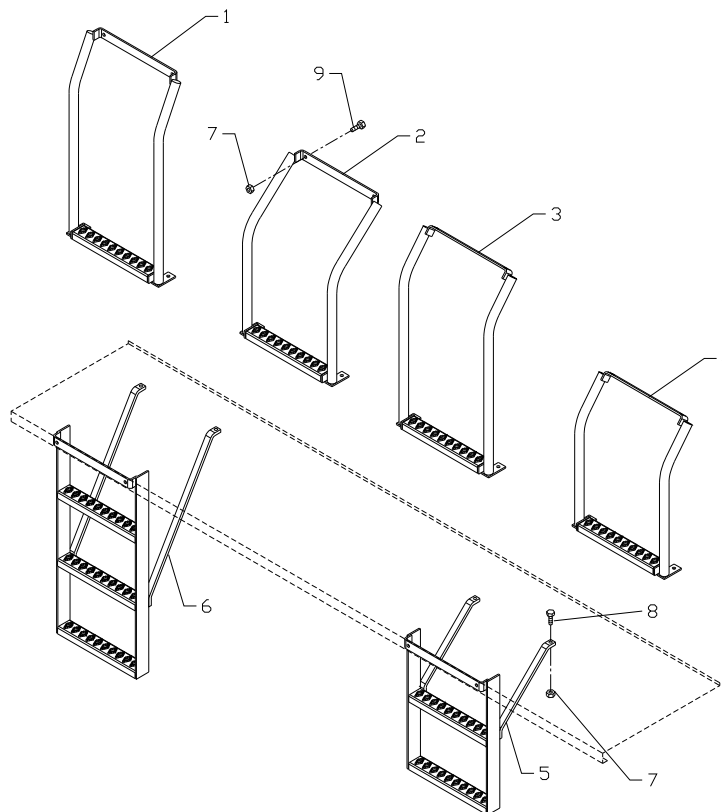

<u>ITEM</u>	<u>PART NO.</u>	<u>DESCRIPTION</u>	<u>QTY</u>
	46458	Group - Ladder	
	46460	Group - Ladder for Units with Raised Fenders	
	53955	Group - Ladder for 96" Wide Units	
	53951	Group - Ladder for 96" Wide Units with Raised Fenders	
1	72795	Ladder - Upper	1
2	72777	Ladder - Upper for Units with Raised Fenders	1
3	72779	Ladder - Upper for 96" Wide Units	1
4	72778	Ladder - Upper for 96" Wide Units with Raised Fenders	1
5	72797	Ladder - Lower	1
6	72796	Ladder - Lower for Units with Raised Fenders	1
7	20644	Nut - Hex, 3/8	8
8	20069	Cap Screw - 3/8 x 1 1/2	2
9	20068	Cap Screw - 3/8 x 1 1/4	6



Please Give Part No., Description and Unit Serial No.

97373-D

HILLSIDE FLOW DIVIDER

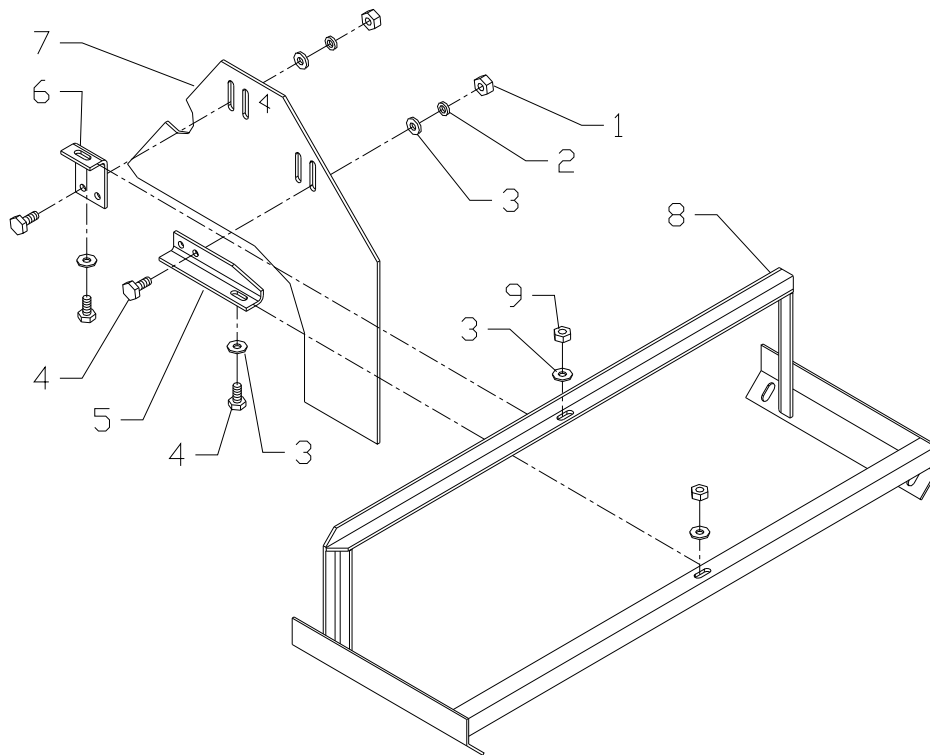

<u>ITEM</u>	<u>PART NO.</u>	<u>DESCRIPTION</u>	<u>QTY</u>
1	36413	Nut – Hex 5/16 SS	4
2	36419	Washer – Lock 5/16 SS	4
3	36424	Washer – Flat 5/16 SS	8
4	34580	Cap Screw - 5/16 x 1 SS	6
5	56879	Bracket – Clamp SS	1
6	56880	Angle – Clamp SS	1
7	56878	Panel – Divider SS for #5 Conveyor	1
	82288	Panel – Divider SS for #4 BOC	1
8	56926	Support Weldment, SS	1
9	20677	Nut – Lock 5/16 SS	2



Please Give Part No., Description and Unit Serial No.

97373-D

MATERIAL DIVIDER

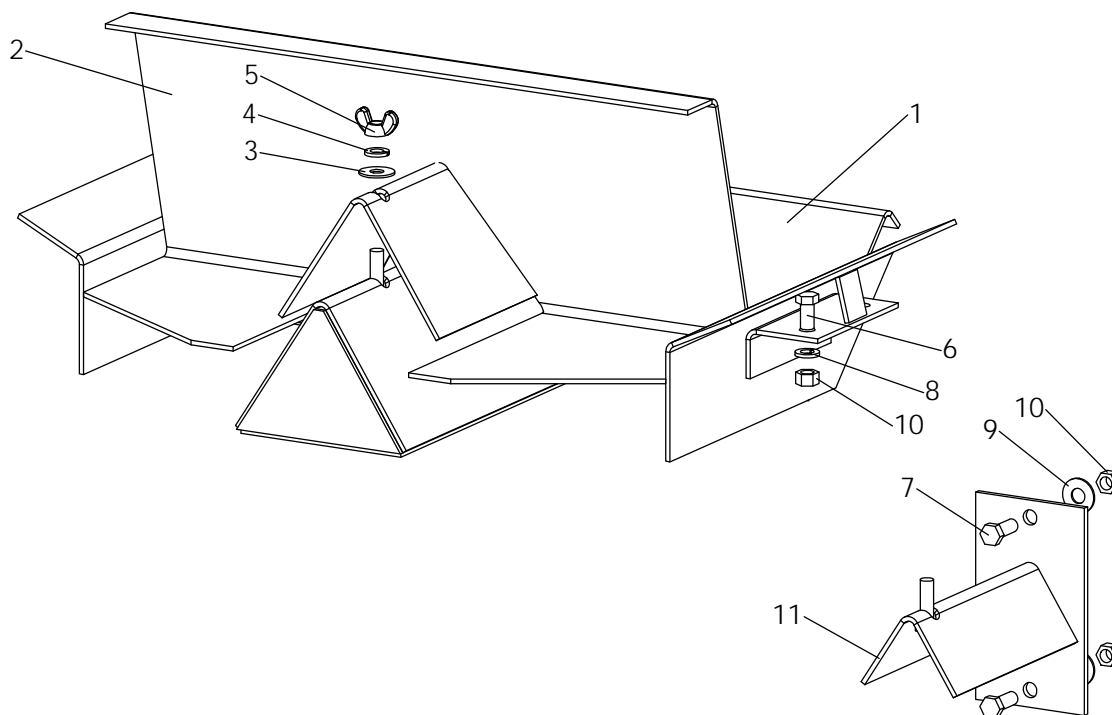

<u>ITEM</u>		<u>PART NO.</u>	<u>DESCRIPTION</u>	<u>QTY</u>
	CS	SS		
	87107	87107	Divider – Material Assembly, Includes Items 1 & 2	
1	87037	87037	Divider – Weldment	1
2	87045	87045	Deflector – Rear Weldment	1
3	36425	36425	Washer – Flat 3/8 SS	1
4	36420	36420	Washer – Lock 3/8 SS	1
5	20673	20673	Nut – Wing 3/8	1
6	20065	36293	Cap Screw – 3/8 x 3/4	2
7	20067	20067	Cap Screw – 3/8 x 1	2
8	20712	36420	Washer – Lock 3/8	2
9	20693	20693	Washer – Flat 3/8	2
10	20644	36414	Nut – Hex 3/8	4
11	87381	87381	Mount – Divider Weldment	1

Mount Item 11 on truck to hold Item 2 when not in use.



SPINNER GUARD & SHIELDS

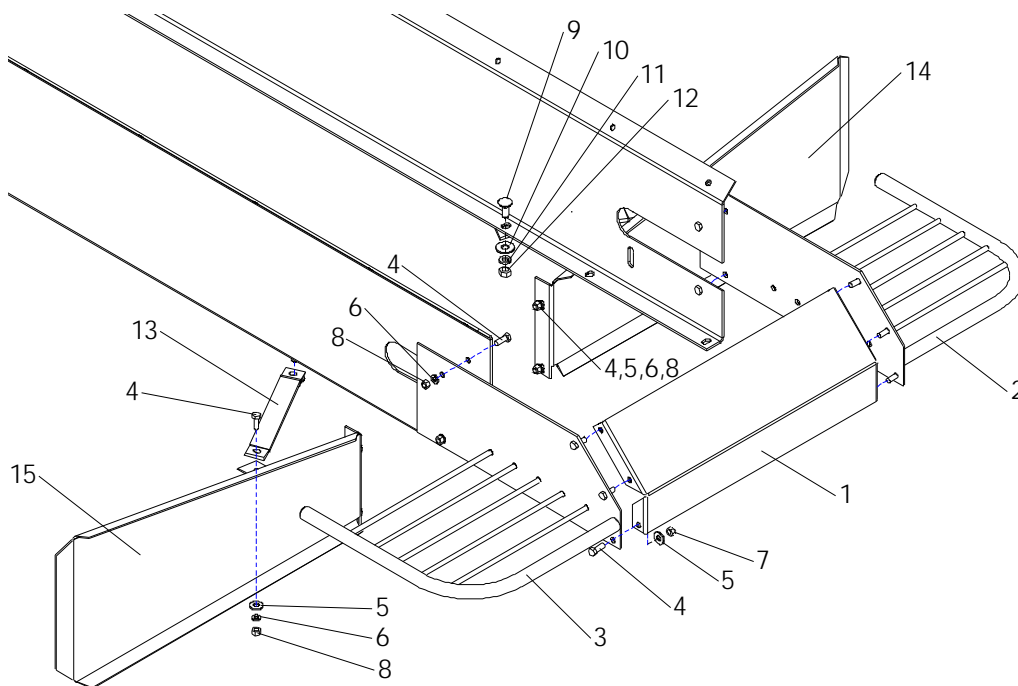

WARNING

Guards are intended to reduce hazard of entanglement with machinery and injury. All guards must be installed per this drawing before spreader is put into operation.

<u>ITEM</u>	<u>PART NO.</u>		<u>DESCRIPTION</u>	<u>QTY</u>
	CS	SS		
1	87026	87026-X1	Guard – Center Section Weldment	1
2	87027	87027-X1	Guard – RH Weldment	1
3	87031	87031-X1	Guard – LH Weldment	2
4	20067	36398	Cap Screw - 3/8 x 1	16
5	20693	36425	Washer – Flat 3/8	12
6	20712	36420	Washer – Lock 3/8	10
7	20678	72054	Nut – Lock 3/8	6
8	20644	36414	Nut - Hex 3/8	10
9	20368	36940	Bolt – Carriage 1/2 x 1	2
10	20695	36426	Washer – Flat 1/2	2
11	20714	36422	Washer - Lock 1/2	2
12	20646	36416	Nut – Hex 1/2	2
13	87067	87068	Bar – Stiffener	2
14	82960	82964	Shield – RH Weldment (Attach to fan frame)	1
15	82961	82965	Shield – LH Weldment (Attach to fan frame)	1

24" HYDRAULIC FANS

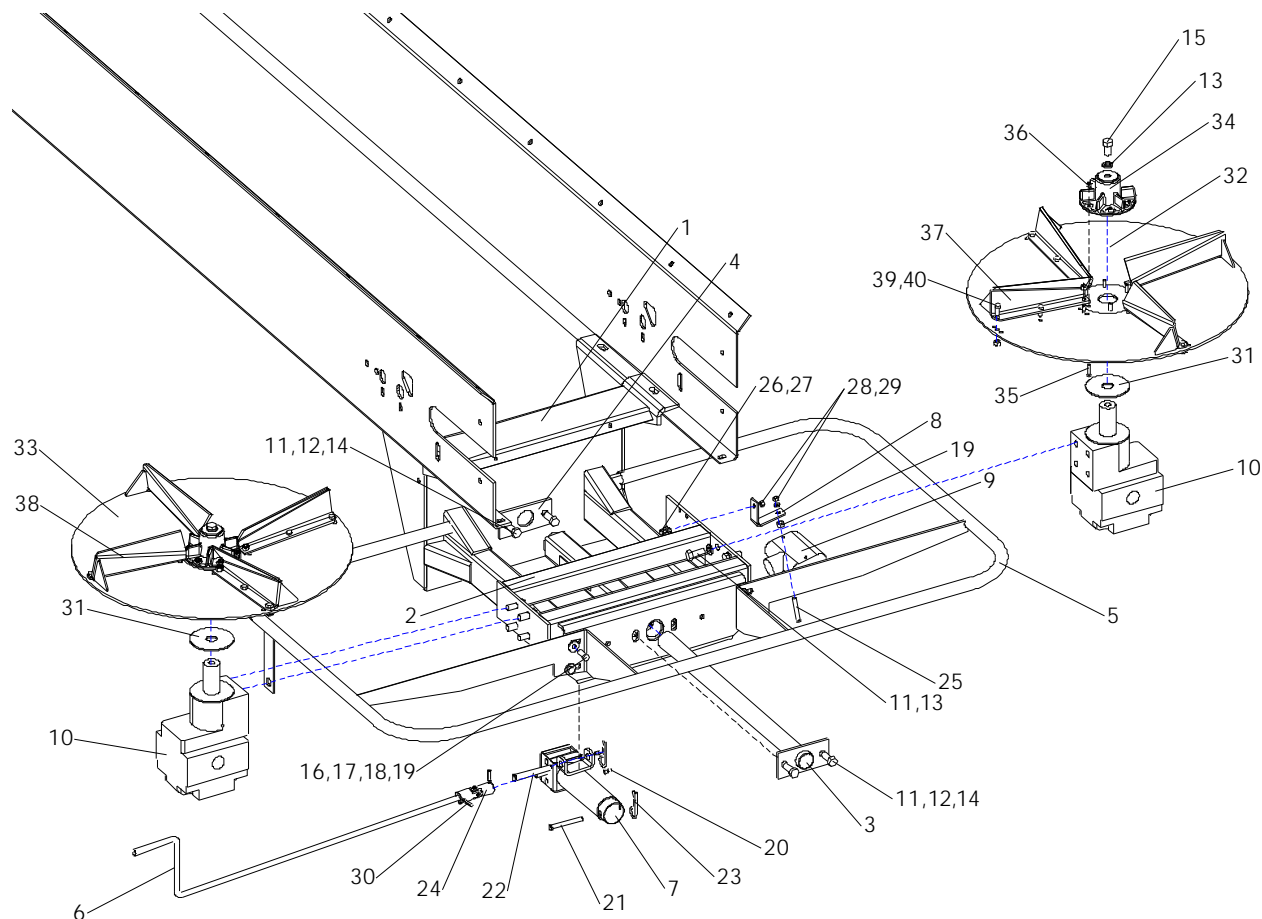

<u>ITEM</u>	<u>PART NO.</u>		<u>DESCRIPTION</u>	<u>QTY</u>
	CS	SS		
	87094	87093	24" Hydraulic Fan Assembly	
			NOTE: Assembly does not include guards.	
	87106	87106	Fan – LH Assembly, Includes Items 33-40	1
	87105	87105	Fan – RH Assembly, Includes Items 32, 33-40	1
1	87000	87069	Plate – Back	1
2	87013	87082	Mount – Motor Weldment	1
3	87021	87021	Shaft – Support Weldment	1
4	87065	87023	Plate – Shaft Mount	1
5	87032	87032-X1	Guard – Spinner Weldment	1
6	87024	87024	Handle	1
7	87170	87170	Jack – Coated Assy	1
8	87053	87053	Angle – Valve Mount	1



Please Give Part No., Description and Unit Serial No.

24" HYDRAULIC FANS CONTINUED

<u>ITEM</u>	<u>PART NO.</u>		<u>DESCRIPTION</u>	<u>QTY</u>
	CS	SS		
9	43510	43510	Valve – Flow Divider	1
	56368	56368	Spool – Compensating	1
10	305944	305944	Motor – Hydraulic	2
	306090		Speedi-Sleeve	1
	306429		Speedi-Tool	1
11	20128	36402	Cap Screw - 1/2 x 1 1/4	12
12	20695	36426	Washer – Flat 1/2	4
13	20714	36422	Washer – Lock 1/2	10
14	20680	39016	Nut – Lock 1/2	4
15	20127	36401	Cap Screw - 1/2 x 1	2
16	20067	36398	Cap Screw - 3/8 x 1	4
17	20693	36425	Washer – Flat 3/8	4
18	20712	36420	Washer – Lock 3/8	4
19	20644	36414	Nut – Hex 3/8	5
20	6072	6072	Zerk – Grease	4
21	6547	6547	Pin – Clevis	1
22	87048	87048	Pin – Clevis	1
23	40576	40576	Pin – Hair	2
24	85002	85002	U-Joint	1
25	20010	34865	Cap Screw – 1/4 x 2 1/4	1
26	20005	36395	Cap Screw – 1/4 x 1	1
27	20691	36423	Washer – Flat 1/4	1
28	20710	36418	Washer – Lock 1/4	2
29	20642	36412	Nut – Hex 1/4	2
30	20918	20918	Pin – Roll	2
31	305571	305571	Washer – Rubber	2
32	27056-X4	27056-X4	Disc – Distributor RH	1
33	27056-X5	27056-X5	Disc – Distributor LH	1
34	10877	10877	Hub	2
35	20004	20004	Cap Screw - 1/4 x 7/8	12
36	20676	20676	Nut - Lock 1/4	12
37	25870	25870-X1	Fin - RH Weldment	4
38	25871	25871-X1	Fin – LH Weldment	4
39	20034	20034	Cap Screw – 5/16 x 3/4	24
40	20677	20677	Nut – Lock 5/16	24
41	* 20368	36940	Bolt – Carriage 1/2 x 1	4
42	* 20695	36426	Washer – Flat 1/2	4
43	* 20714	36422	Washer – Lock 1/2	4
44	* 20646	36416	Nut – Hex 1/2	4

* - Not Shown – Used to attach spinner to sills.



Please Give Part No., Description and Unit Serial No.

SPINNER SENSOR

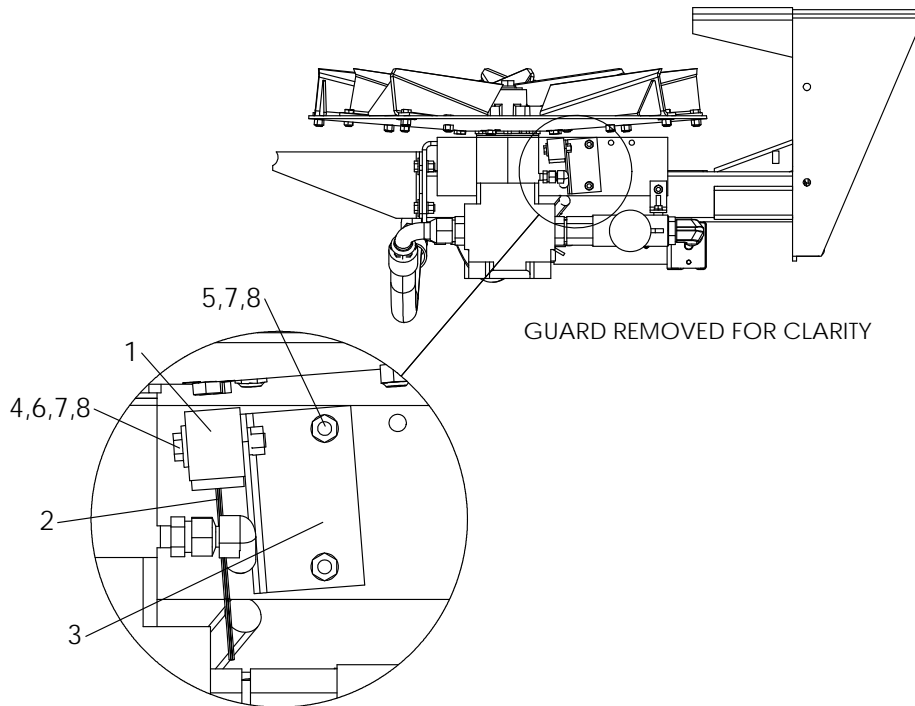

<u>ITEM</u>	<u>PART NO.</u>	<u>DESCRIPTION</u>	<u>QTY</u>
	97310	Sensor – Kit Spinner	
1	89011	Sensor – Assembly	1
2	89009	Cable – Sensor Extension	1
3	86672	Bracket	1
4	42448	Cap Screw – 1/4 x 1-1/2 SS	2
5	36393	Cap Screw – 1/4 x 3/4 SS	2
6	36423	Washer – Flat 1/4 SS	2
7	36418	Washer – Lock 1/4 SS	4
8	36412	Nut – Hex 1/4 SS	4

RESERVOIR

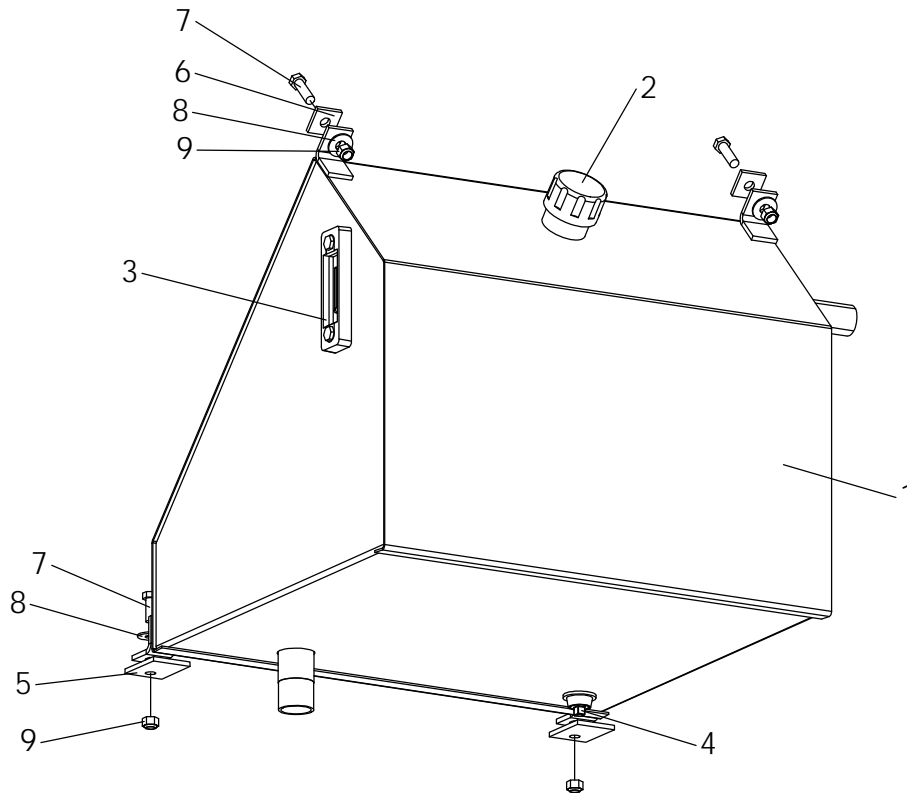

<u>ITEM</u>	<u>PART NO.</u>		<u>DESCRIPTION</u>	<u>QTY</u>
	CS	SS		
	86484	86484	Reservoir Assembly, Includes Items 1, 2, 4 & 10	
1	86464	86464	Tank – Weldment	1
2	96747	96747	Cap – Filler	1
3	38575	38575	Gauge – Sight & Temperature	1
4	6033	6033	Plug – Pipe	1
5	39158	39158	Belt – Flex Mount	2
6	39159	39159	Belt – Flex Mount	2
7	20069	34858	Cap Screw - 3/8 x 1 1/2	4
8	20693	36425	Washer – Flat 3/8	4
9	20678	72054	Nut – Lock 3/8	4
10	* 6031	6031	Plug – Pipe	1

* - Not Shown



Please Give Part No., Description and Unit Serial No.

97373-D

RESERVOIR/PUMP HYDRAULICS

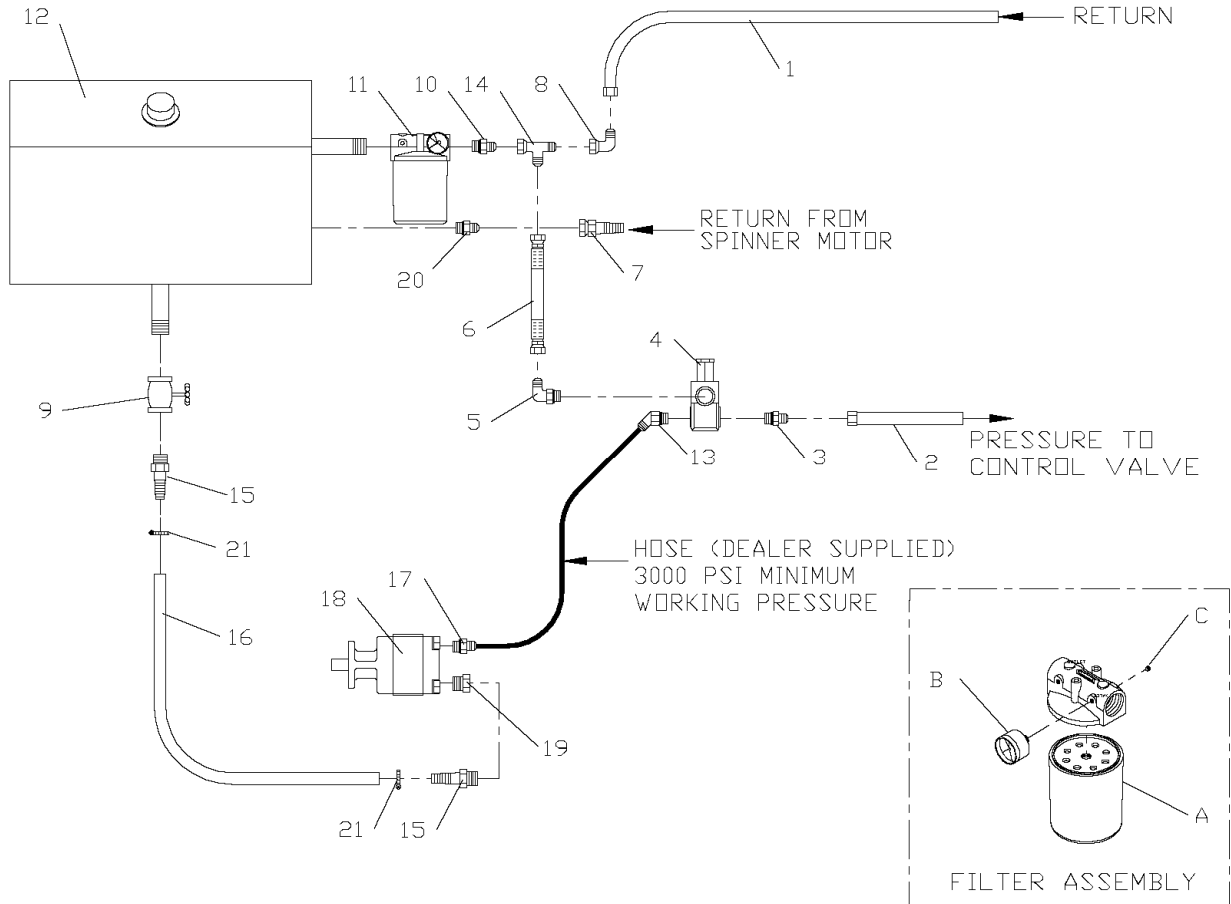

<u>ITEM</u>	<u>PART NO.</u>	<u>DESCRIPTION</u>	<u>QTY</u>
1	98145	Tube Assembly for: 8' Unit	1
	98520	10' Unit	1
	98521	11' Unit	1
	98522	12' & 12'6" Units	1
	98523	13' Unit	1
	98524	14' Unit	1
	98525	15' Unit	1
	98526	16' Unit	1
2	98110	Tube Assembly for: 8' Unit	1
	98111	10' Unit	1
	98112	11' Unit	1
	98113	12' Unit	1
	98114	12'6" Unit	1
	98115	13' Unit	1
	98117	14' Unit	1
	98119	15' Unit	1
	98122	16' Unit	1



Please Give Part No., Description and Unit Serial No.

97373-D

RESERVOIR/PUMP HYDRAULICS CONTINUED

<u>ITEM</u>	<u>PART NO.</u>	<u>DESCRIPTION</u>	<u>QTY</u>
3	29803	Fitting – 16-16 070120	1
4	98109	Valve – Relief 3100 PSI	1
5	29840	Fitting – 16-16 070220	1
6	81336	Hose – 1 x 17-7/8”	1
	82512	Hose – 1 x 12-3/4”, 11’ Units	1
7	34761	Fitting – Socketless	1
8	29807	Fitting – 16-16 070221	1
9	21409	Valve – Gate	1
10	34724	Fitting – 16-20 070102	1
11	39845	Filter – Oil	1
A	43530	Filter Element	1
B	43534	Indicator	1
C	6029	Plug – Pipe	3
12	86464	Tank – Hydraulic	1
	38575	Gauge – Sight & Temperature	1
13	34726	Fitting – 16-16 070320	1
14	29850	Fitting – 16-16-16 070432	1
15	31680	End – Hose	2
16	21878-108	Hose – Suction 1-1/2 x 108, Direct Mount	1
	21878-72	Hose – Suction 1-1/2 x 72, Driveline Mount	1
17	34845	Adapter	1
18	86664	Pump – 3.85 CID	1
	86665	Pump – 4.38 CID	1
19	29780	Bushing	1
20	29766	Fitting – 6-6 070102	1
21	6288	Clamp – Hose	2



Please Give Part No., Description and Unit Serial No.

97373-D

TWIN SPINNER HYDRAULICS

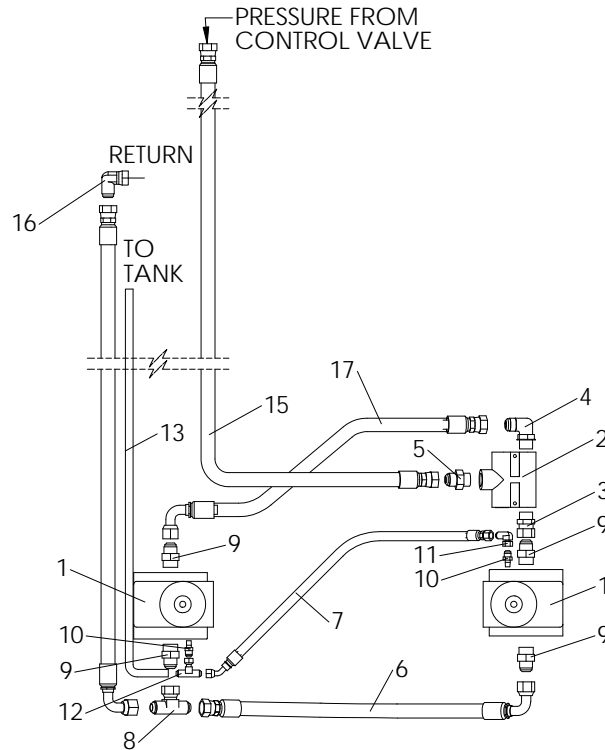

ITEM	PART NO.	DESCRIPTION	QTY
1	305944	Motor - Spinner	2
	306090	Speedi-Sleeve	1
	306429	Speedi-Tool	1
2	43510	Valve - Flow Divider	1
	56368	Spool - Compensating	1
3	29788	Adapter	1
4	29847	Adapter - 90° Elbow	1
5	29789	Adapter	1
6	87049	Hose Assembly	1
7	87112	Hose Assembly	1
8	29809	Adapter - Tee	1
9	34717	Adapter - Connector	4
10	34763	Adapter	2
11	34816	Adapter - 90° Elbow	1
12	29825	Adapter - Tee	1
13	34195-180	Hose - Drain Line	1
14	87115	Hose - Return Assy, Use w/ Mark Hydraulics	1
	87166	Hose - Return Assy, Use w/ Manual/Raven Hyd.	1
15	98104	Hose - Pressure Assembly	1
16	34709	Adapter - Elbow 90°, Manual Hydraulics only	1
17	98108	Hose - Assembly	1



Please Give Part No., Description and Unit Serial No.

97373-D

MARK SERIES CONTROL HYDRAULICS – SINGLE PINION

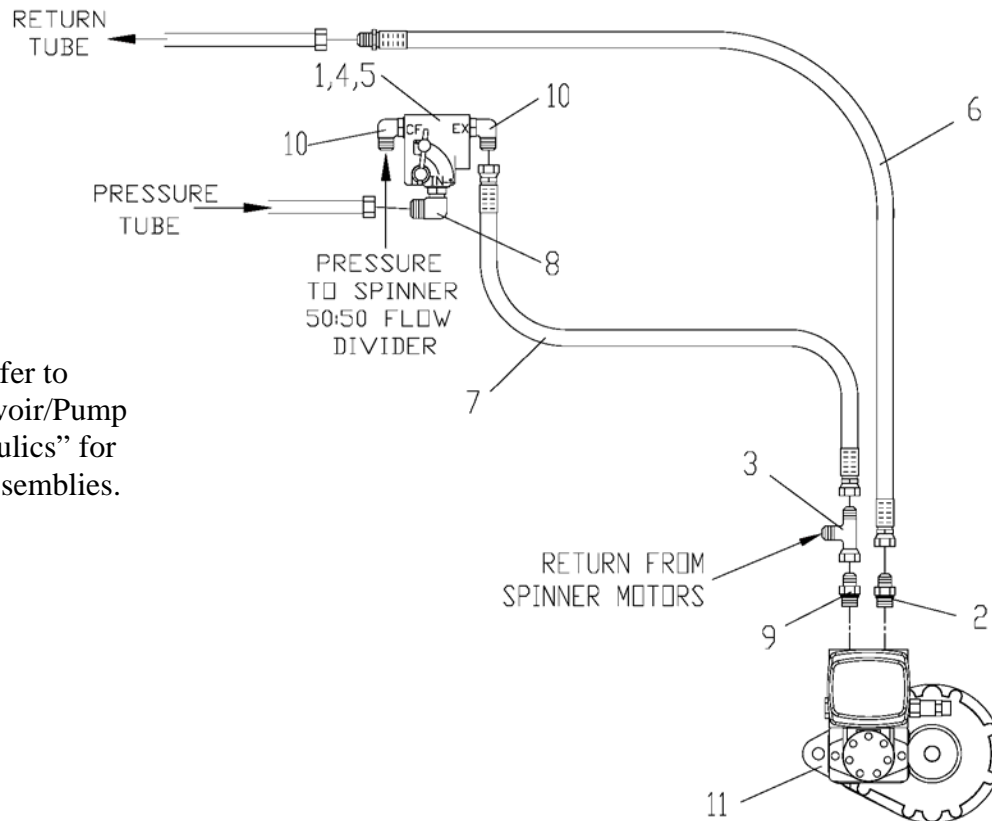

Refer to
"Reservoir/Pump
Hydraulics" for
tube assemblies.

ITEM	PART NO.	DESCRIPTION	QTY
1	32485	Valve – Control	1
2	29803	Adapter – Connector	1
3	29781	Adapter – Tee	1
4	20011	Cap Screw – 1/4 x 2 1/2	2
5	20676	Nut – Lock, 1/4	2
6	81340	Hose – Assembly 1 x 40-1/2 Return	1
	81340-X1	Hose – Assembly 1 x 43-1/2 Return, 12'6" Units	1
7	56125	Hose – Assembly 3/4 x 21	1
8	29838	Adapter – 90° Elbow	1
9	29835	Adapter – Reducing	1
10	29847	Adapter – 90° Elbow	2
11	88376	Mark V Gear Case Assembly – 1.5" Motor	1
12	84956	Mark IV.4 Gear Case Assembly – 1.5" Motor	1
	43501	Gear Case – Single	1
	46395	Motor – Hydraulic, 1.5"	1
	46396	Motor – Hydraulic, 2"	1



Please Give Part No., Description and Unit Serial No.

97373-D

MARK SERIES CONTROL HYDRAULICS – DUAL PINION

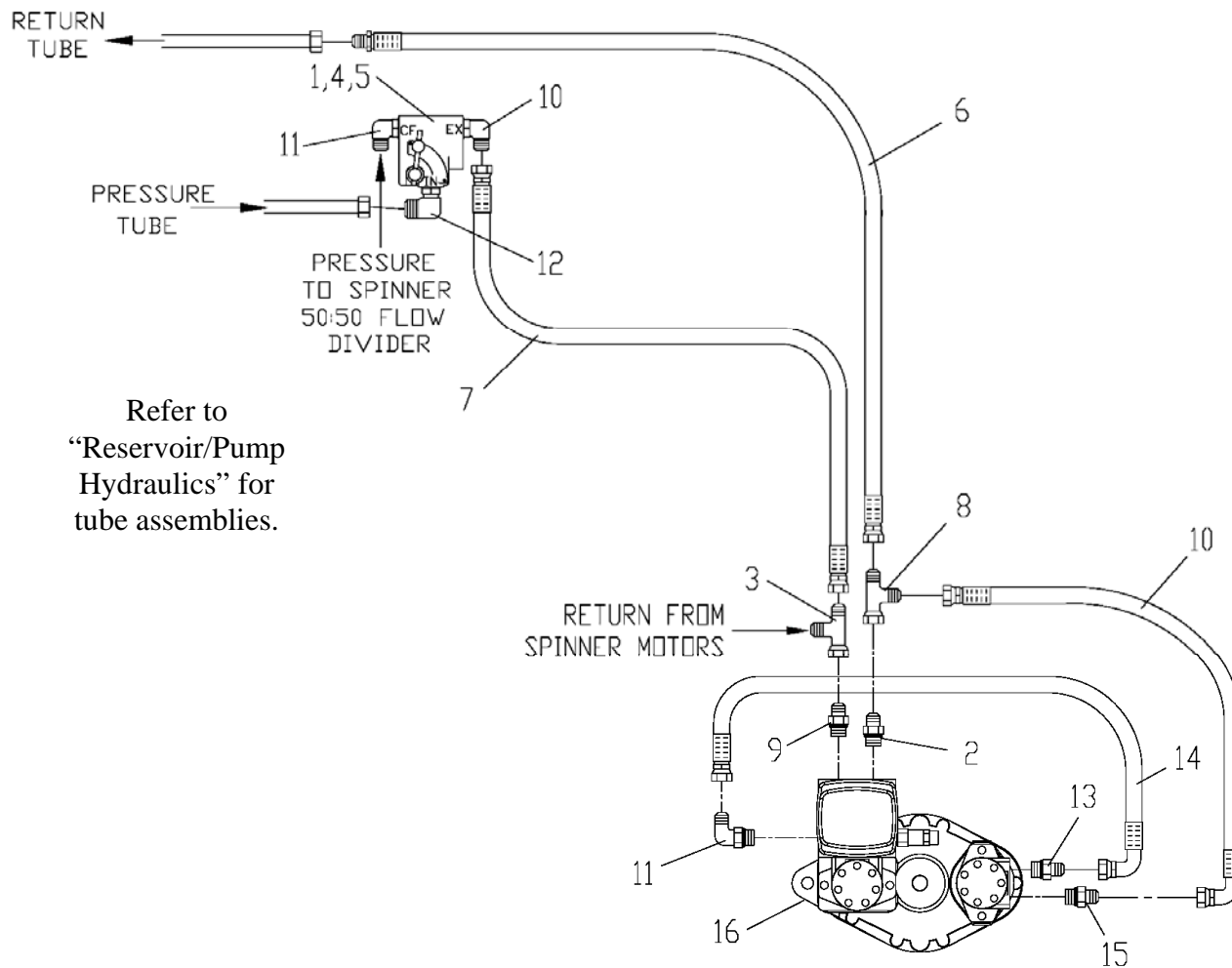

<u>ITEM</u>	<u>PART NO.</u>	<u>DESCRIPTION</u>	<u>QTY</u>
1	32485	Valve – Control	1
2	29803	Adapter – Connector	1
3	29781	Adapter – Tee	1
4	20011	Cap Screw – 1/4 x 2 1/2	2
5	20676	Nut – Lock 1/4	2
6	42996	Hose – Assembly 1 x 32-7/8 Return	1
7	56125	Hose – Assembly 3/4 x 21	1
8	29850	Adapter – Tee	1
9	29835	Adapter - Reducing	1



MARK SERIES CONTROL HYDRAULICS – DUAL PINION CONTINUED

<u>ITEM</u>	<u>PART NO.</u>	<u>DESCRIPTION</u>	<u>QTY</u>
10	56121	Hose – Assembly 1 x 18-1/2	1
11	29847	Adapter - 90° Elbow	2
12	29838	Adapter – 90° Elbow	1
13	29753	Adapter – Connector	1
14	54773	Hose – Assembly 3/4 x 32	1
15	29778	Adapter – Connector	1
16	88377	Mark V Gear Case Assembly – 1” Motors	1
	88378	Mark V Gear Case Assembly – 1.25” Motors	1
	88379	Mark V Gear Case Assembly – 1.5” Motors	1
	84957	Gear Case – Dual Mark IV.4 Assembly	1
	55971	Gear Case – Dual	1
	Modified	Standard	
	55972	55970	Motor – Hydraulic 1” 1 EACH
	82462	82459	1.25” 1 EACH
	46395	38897	1.5” 1 EACH
17	*306890	Breather Tube – Assembly Gear Case	1
	306891	Fitting – 4-2 630202K	1
	9005-0-7661	Tubing – 1/4 OD Air Brake	Feet 1.5

* - Not Shown



Please Give Part No., Description and Unit Serial No.

97373-D

MANUAL DUAL HYDRAULICS – SINGLE PINION

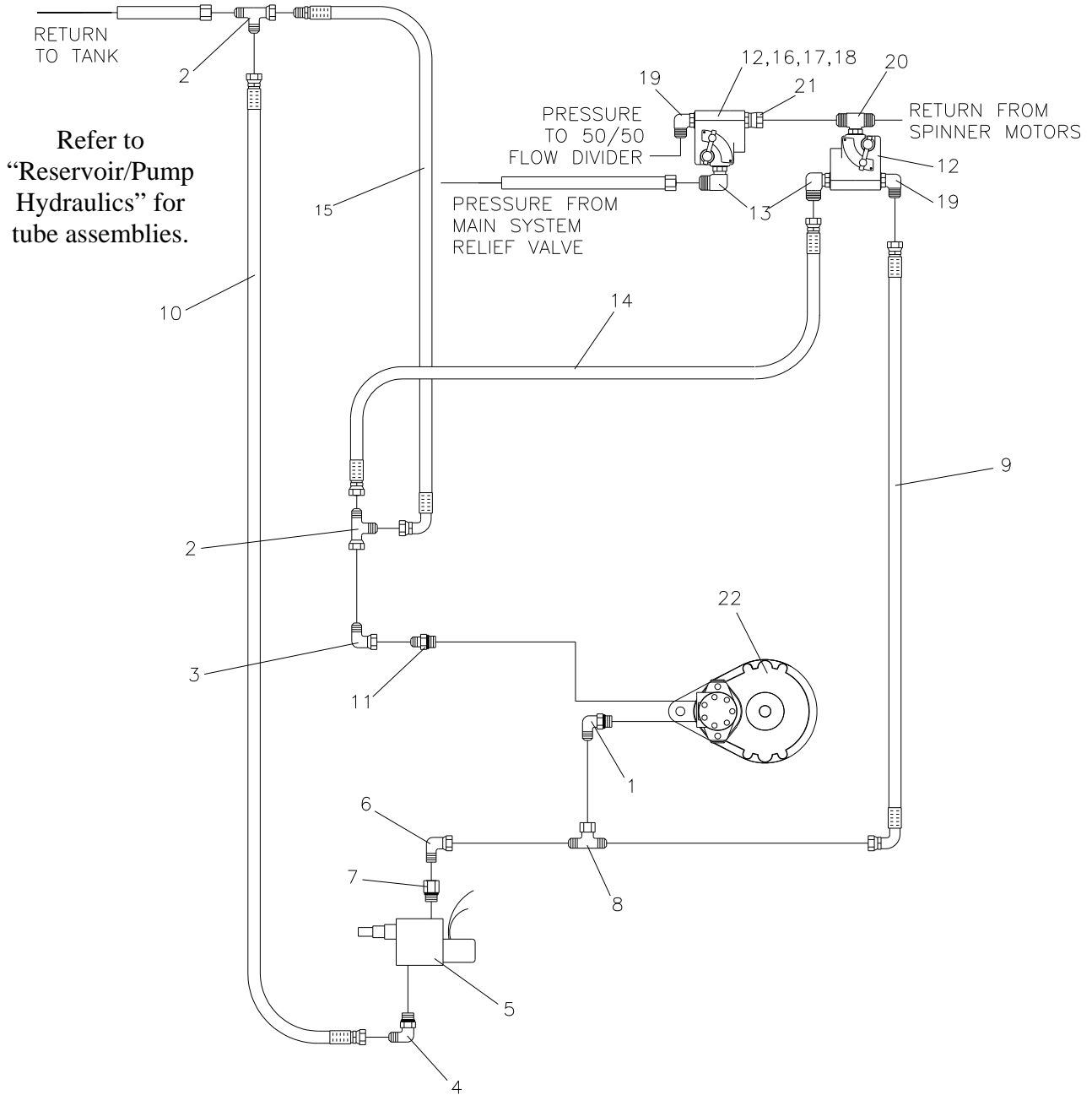

Please Give Part No., Description and Unit Serial No.

97373-D

MANUAL DUAL HYDRAULICS – SINGLE PINION CONTINUED

<u>ITEM</u>	<u>PART NO.</u>	<u>DESCRIPTION</u>	<u>QTY</u>
1	29773	Adapter – Elbow 90°	1
2	29850	Adapter – Tee	2
3	29807	Adapter – Elbow 90°	1
4	29840	Adapter – Elbow 90°	1
5	56297	Valve – 2000 PSI Solenoid with Relief	1
6	29827	Adapter – Elbow 90°	1
7	21505	Adapter – Bushing	1
8	29809	Adapter – Tee	1
9	71473	Hose – Assembly 3/4 x 29	1
10	79557	Hose – Assembly 1 x 44 Return	1
11	29778	Adapter – Connector	1
12	32485	Valve – Control	2
13	29838	Adapter – Elbow 90°	2
14	82527	Hose – Assembly 1 x 17-1/2 Return	1
15	84109	Hose – Assembly 1 x 43-3/4 Return	1
16	20011	Cap Screw – 1/4 x 2 1/2	2
17	20691	Washer – Flat 1/4	2
18	20676	Nut – Lock 1/4	2
19	29847	Adapter – Elbow 90°	2
20	34715	Adapter – Tee	1
21	29788	Adapter – Connector	1
22	57301	Gear Case Assembly – 1.5” Motor	1
	57302	Gear Case Assembly – 2” Motor	1
	36671	Gear Case – Single Pinion Assembly	1
	38897	Motor – Hydraulic 1.5”	1
	38898	Motor – Hydraulic 2”	1



MANUAL DUAL HYDRAULICS – DUAL PINION

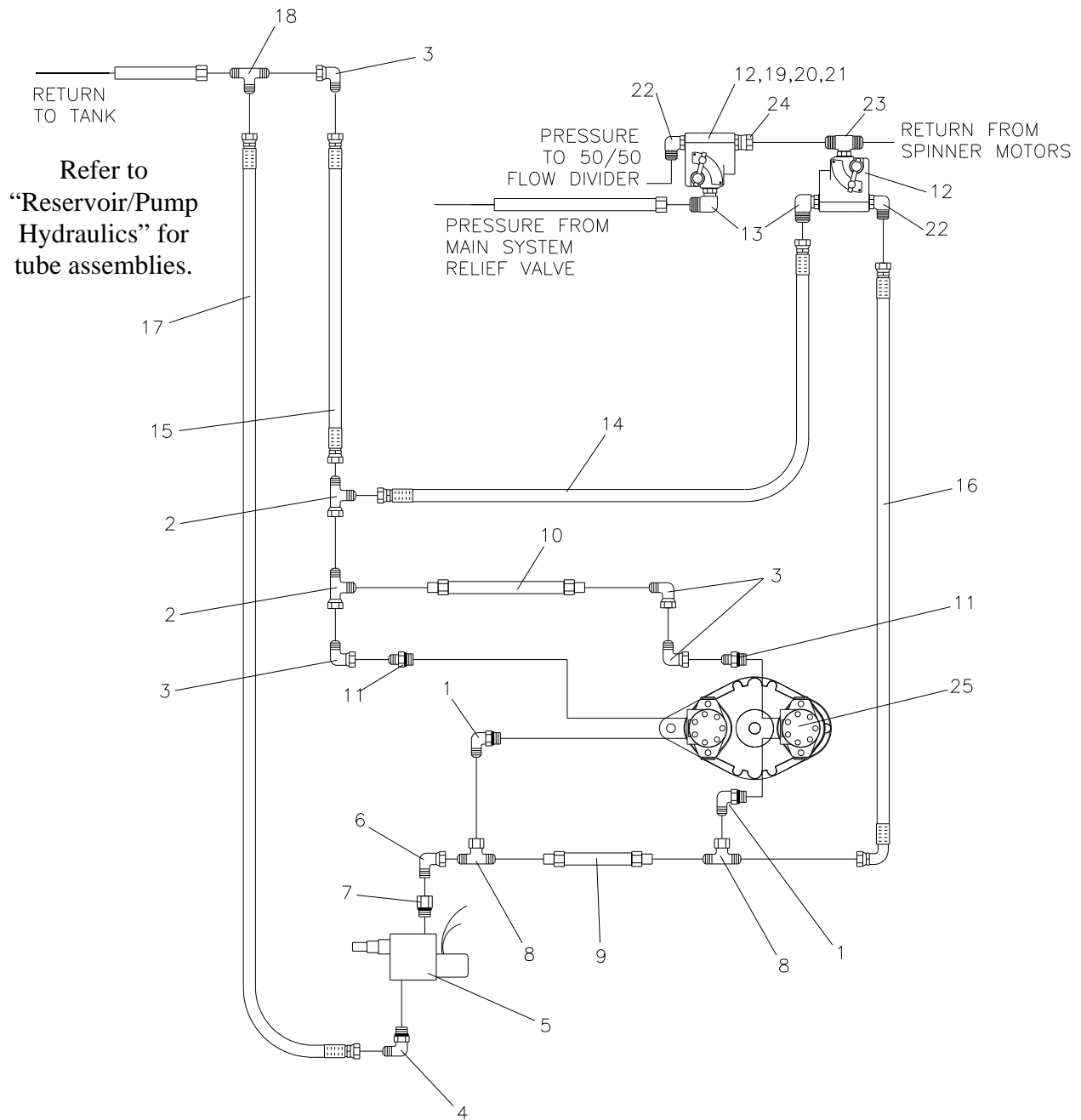

Please Give Part No., Description and Unit Serial No.

97373-D

MANUAL DUAL HYDRAULICS – DUAL PINION CONTINUED

<u>ITEM</u>	<u>PART NO.</u>	<u>DESCRIPTION</u>	<u>QTY</u>
1	29773	Adapter – Elbow 90°	1
2	29850	Adapter – Tee	2
3	29807	Adapter – Elbow 90°	1
4	29840	Adapter – Elbow 90°	1
5	56297	Valve – 2000 PSI Solenoid with Relief	1
6	29827	Adapter – Elbow 90°	1
7	21505	Adapter – Bushing	1
8	29809	Adapter – Tee	1
9	80886	Tube – Assembly	1
10	80888	Tube – Assembly	1
11	29778	Adapter – Connector	1
12	32485	Valve – Control	2
13	29838	Adapter – Elbow 90°	2
14	82532	Hose – Assembly 1 x 21 Return	1
15	84598	Hose – Assembly 1 x 26-1/2 Return	1
16	54773	Hose – Assembly 3/4 x 32	1
17	82599	Hose – Assembly 1 x 42	1
18	34711	Adapter – Tee	1
19	20011	Cap Screw – 1/4 x 2 1/2	2
20	20691	Washer – Flat 1/4	2
21	20676	Nut – Lock 1/4	2
22	29847	Adapter – Elbow 90°	2
23	34715	Adapter – Tee	1
24	29788	Adapter – Connector	1
25	57303	Gear Case Assembly – 1” Motors	1
	82463	Gear Case Assembly – 1.25” Motors	1
	57304	Gear Case Assembly – 1.5” Motors	1
	37985	Gear Case – Dual Pinion Assembly	1
	55970	Motor – Hydraulic 1”	2
	82459	Motor – Hydraulic 1.25”	2
	38897	Motor – Hydraulic 1.5”	2



RAVEN II/PWM – SINGLE PINION

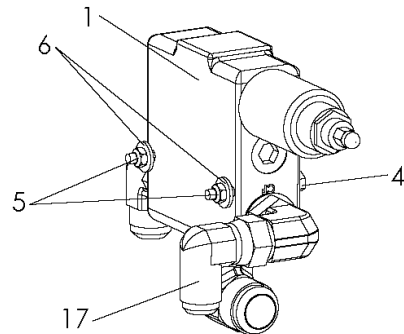
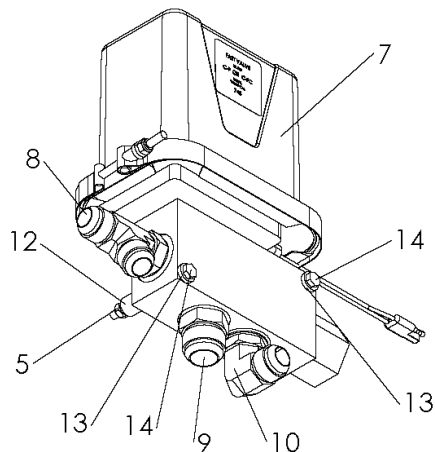
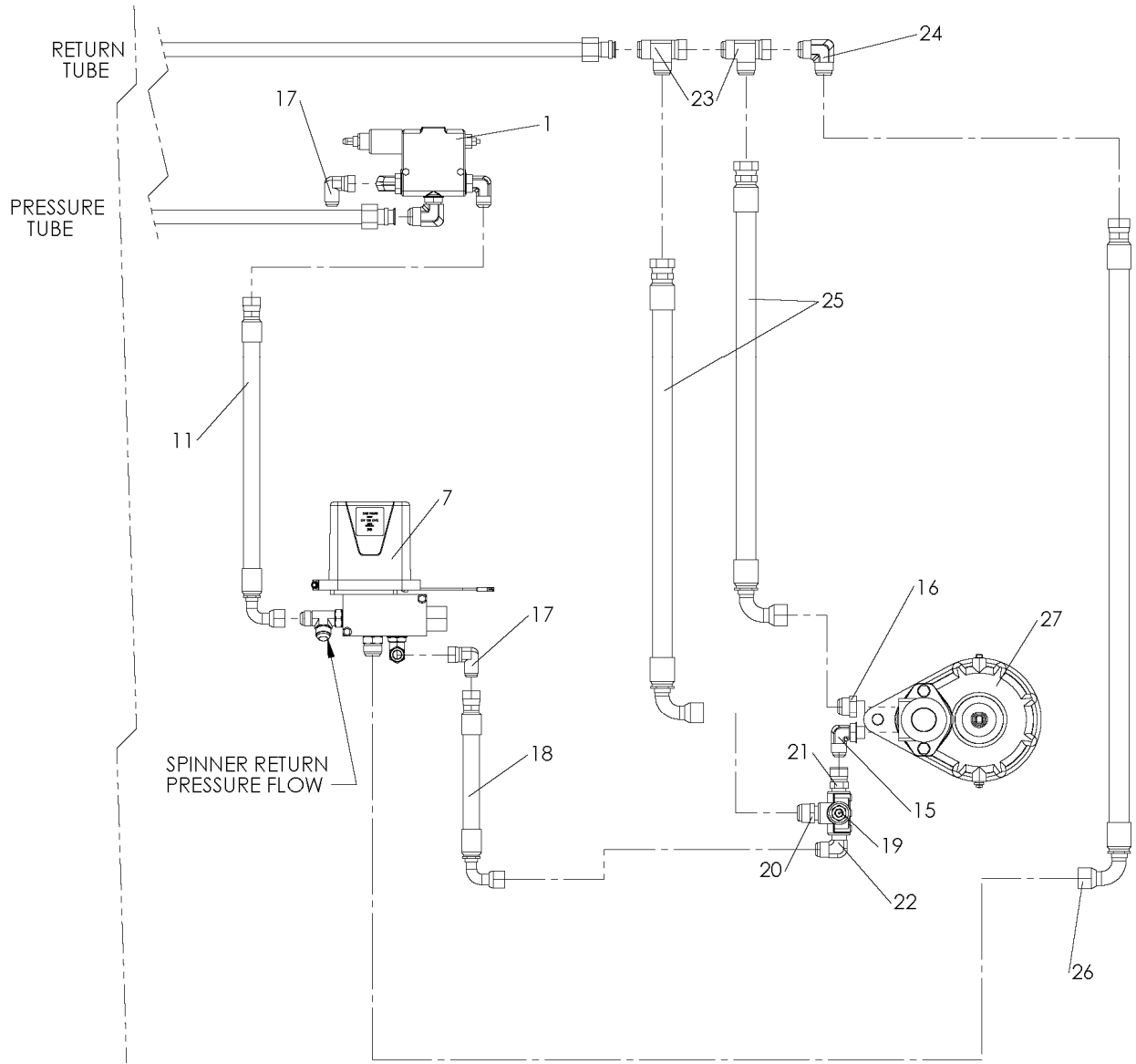

Please Give Part No., Description and Unit Serial No.

97373-D

RAVEN II/PWM – SINGLE PINION CONTINUED

<u>ITEM</u>	<u>PART NO.</u>	<u>DESCRIPTION</u>	<u>QTY</u>
	305396	Hydraulics Group – Raven II/PWM Single Pinion	
1	32485-X1	Valve – Control PWM	1
2	29847	Adapter – Elbow, 90°	2
3	29838	Adapter – Elbow, 90°	1
4	34501	Capscrew – 1/4-20NC x 2-1/2 SS	2
5	42034	Nut – Lock 1/4-20 SS	4
6	36423	Washer – Flat 1/4 SS	2
7	86771-X5	Valve – 25 GPM Raven II	1
	306379	Seal – Kit Raven	1
8	29791	Fitting – 12-12-12 070428	1
9	29775	Fitting – 16-12 070120	1
10	29847	Fitting – 12-12 070220	1
11	29638	Hose – Assembly 3/4 100R2 x 23	1
12	302098	Washer – Step	2
13	302097	Washer – Step	2
14	56396	Capscrew 1/4-20 x 3-1/4 SS	2
15	29773	Adapter – Elbow 90°	1
16	29778	Adapter – Reducing	1
17	34709	Adapter - Elbow, 90°	2
18	56104	Hose – Assembly 3/4 x 13-1/2 100R2	1
19	75037	Valve – Relief	1
20	29757	Adapter	1
21	34826	Adapter	1
22	29764	Adapter – Elbow 90°	1
23	29850	Tee – Swivel Nut	2
24	29783	Adapter – Elbow 90°	1
25	85260	Hose – 1 x 32-1/2 2CB Return	2
26	96452	Hose – 1 2CB x 47-1/4 Return	1
27	57301	Gear Case Assembly 1.5 Motor	1
	36671	Gear Case 6:1	1
	38897	Motor – Hydraulic 1.5	1



RAVEN II/PWM – DUAL PINION

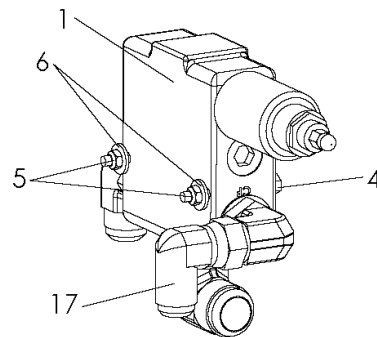
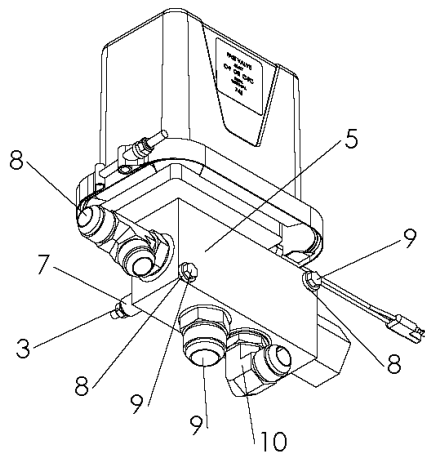
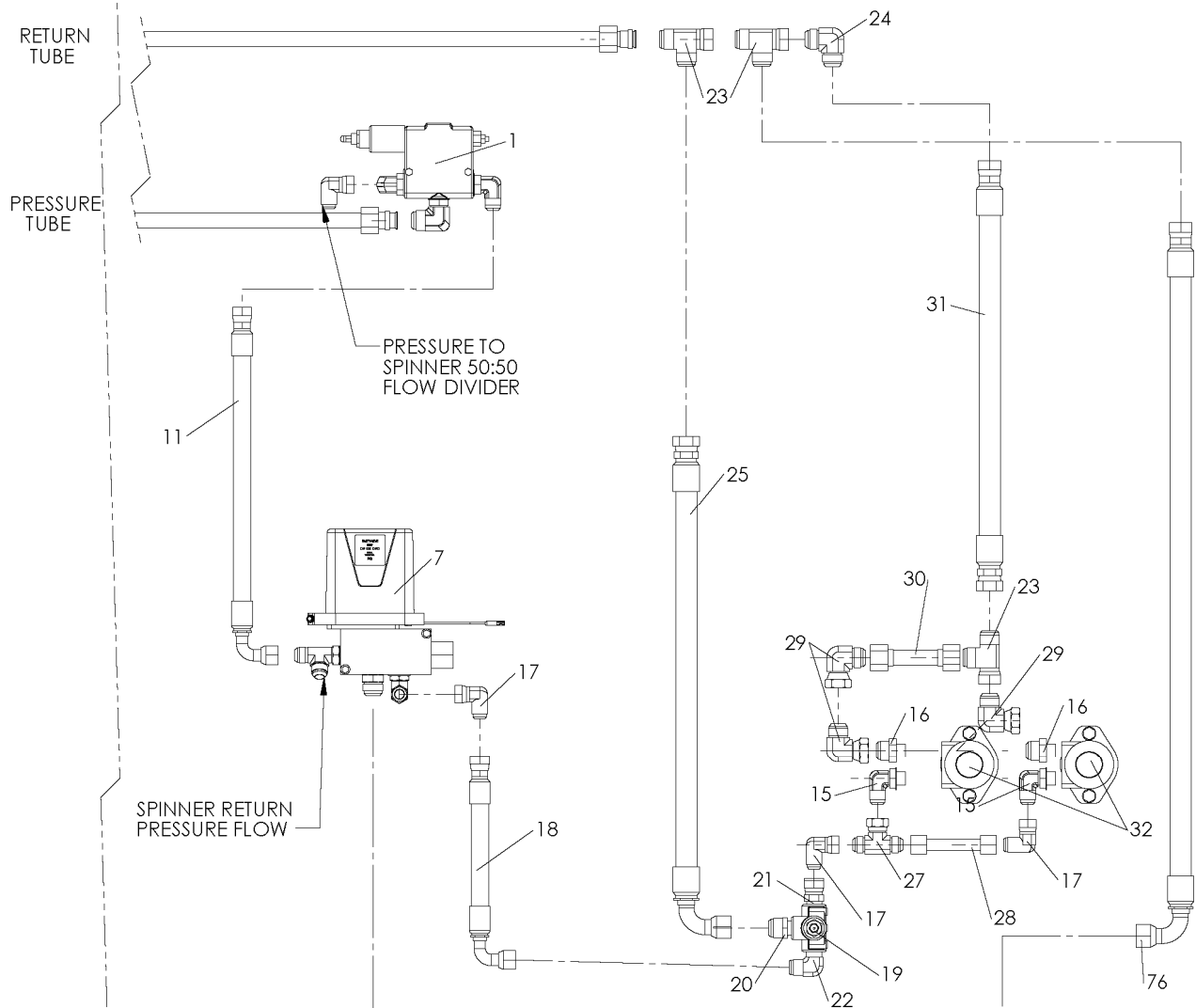

Please Give Part No., Description and Unit Serial No.

97373-D

RAVEN II/PWM – DUAL PINION CONTINUED

<u>ITEM</u>	<u>PART NO.</u>	<u>DESCRIPTION</u>	<u>QTY</u>
	305397	Hydraulics Group – Raven II/PWM Dual Pinion	
1	32485-X1	Valve – Control PWM	1
2	29847	Adapter – Elbow, 90°	2
3	29838	Adapter – Elbow, 90°	1
4	34501	Capscrew – 1/4-20NC x 2-1/2 SS	2
5	42034	Nut – Lock 1/4-20 SS	4
6	36423	Washer – Flat 1/4 SS	2
7	86771-X5	Valve – 25 GPM Raven II	1
	306379	Seal – Kit Raven II	1
8	29791	Fitting – 12-12-12 070428	1
9	29775	Fitting – 16-12 070120	1
10	29847	Fitting – 12-12 070220	1
11	29638	Hose – Assembly 3/4 100R2 x 23	1
12	302098	Washer – Step	2
13	302097	Washer – Step	2
14	56396	Capscrew 1/4-20 x 3-1/4 SS	2
15	29773	Adapter – Elbow 90°	2
16	29778	Adapter – Reducing	2
17	34709	Adapter - Elbow, 90°	4
18	56104	Hose – Assembly 3/4 x 13-1/2 100R2	1
19	75037	Valve – Relief	1
20	29757	Adapter	1
21	34826	Adapter	1
22	29764	Adapter – Elbow 90°	1
23	29850	Tee – Swivel Nut	3
24	29783	Adapter – Elbow 90°	1
25	85260	Hose – 1 x 32-1/2 2CB Return	1
26	96452	Hose – 1 2CB x 47-1/4 Return	1
27	29809	Fitting – 12-12-12 070433	1
28	80886	Tube Assembly 3/4 x 4-7/8	1
29	29807	Fitting – 16-16 070221	3
30	80888	Tube Assembly 1 OD x 2.938	1
31	82958	Hose Assembly 1 CB x 28-1/2 Return	1
32	90889-X3	Gear Case Assembly 1.5 Motor	1
	37985	Gear Case 6:1	1
	303838-X1	Motor – Hydraulic 2000 Series with Speed Sensor	1
	74524	Gasket	4
	34650	Spacer – Gear Case Motor	2
	303838	Motor – Hydraulic 2000 Series	1



SINGLE PINION GEAR CASE

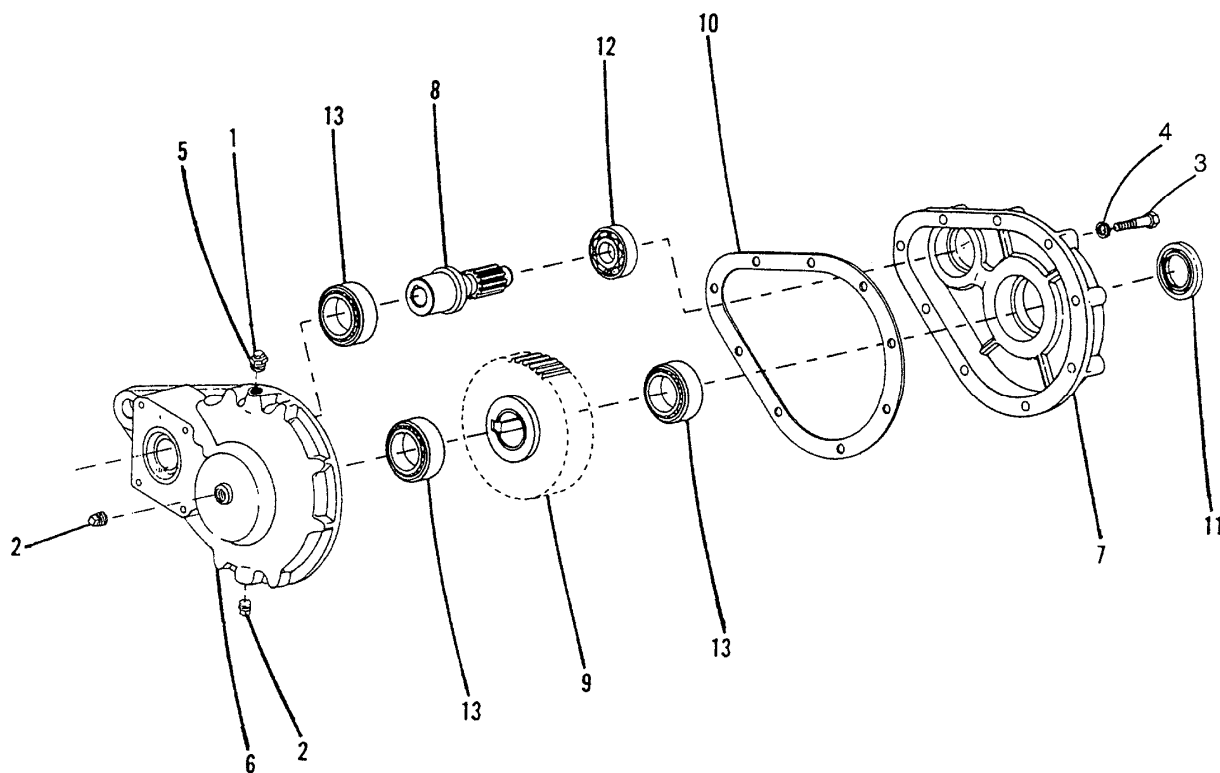

<u>ITEM</u>	<u>PART NO.</u>	<u>DESCRIPTION</u>	<u>QTY</u>
	43501	Gear Case – Assembly Mark series	
1	2564	Cap – Breather	1
2	6031	Plug – Pipe	2
3	20040	Cap Screw – 5/16 x 2	9
4	20711	Washer – Lock 5/16	9
5	27465	Bushing – Pipe	1
6	44403	Housing – Outboard	1
7	37002	Housing – Inboard	1
8	37003	Gear – Pinion	1
9	38981	Gear	1
10	37005	Gasket	1
11	37006	Seal – Oil	1
12	37007	Bearing	1
13	37008	Bearing	3

GEAR CASE – SINGLE PINION

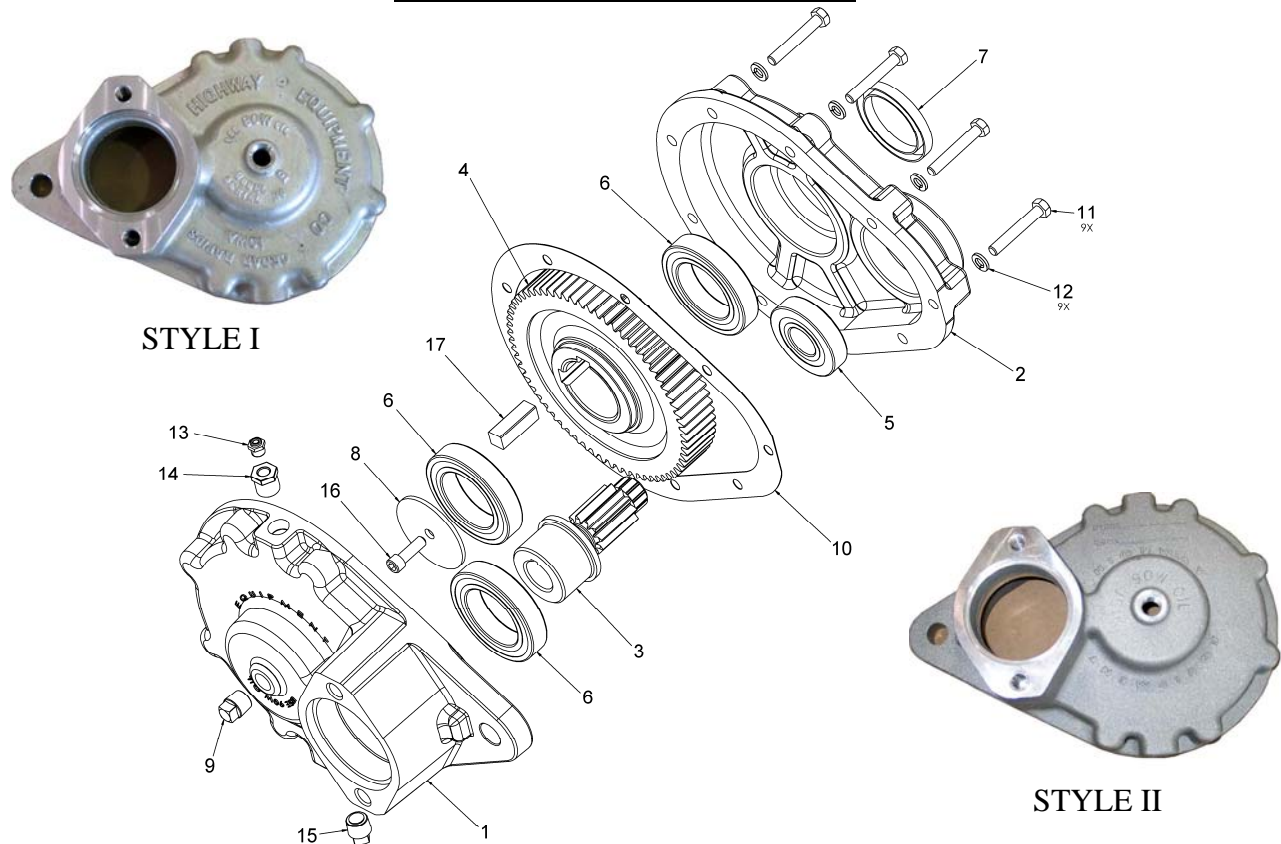

ITEM	PART NO.	DESCRIPTION	QTY
	36671	Gear Case – Assembly Single Pinion	
	Style I	Style II	
	304269-AA	304269-AB	
1	37001	304559 Housing – Outboard	1
2	37002	304560 Housing – Inboard	1
3	37003	304561 Gear – Pinion 11 Tooth	2
4	38981	304562 Gear – Driven 67 Tooth	1
5	37007	37007 Bearing	2
6	37008	37008 Bearing	4
7	37006	37006 Seal – Oil	1
8	38979	38979 Washer – Flat 2-1/2 x 11/32	2
9	6031	6031 Plug – Pipe	1
10	37005	304563 Gasket – Housing	1
11	20040	20040 Cap Screw – 5/16NC x 2	10
12	20711	20711 Washer – Lock 5/16	10
13	2564	2564 Cap – Breather	1
14	27465	27465 Bushing – Pipe 1/8 x 3/8	1
15	21490	21490 Plug – Pipe Magnetic	1
16	38980	38980 Screw – Allen Head 5/16-18 x 1	1
17	37010	37010 Key – 1/2 x 1/2 x 1-1/2	2



Please Give Part No., Description and Unit Serial No.

GEAR CASE

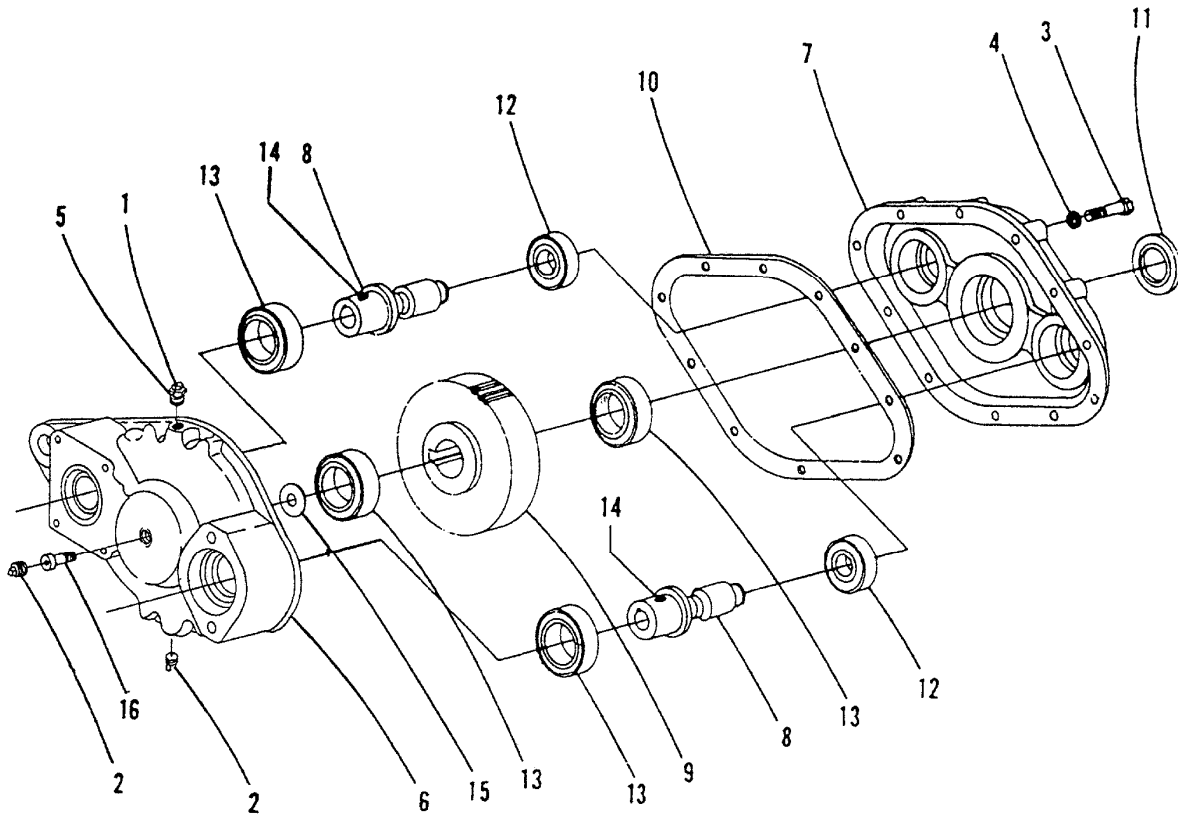

<u>ITEM</u>	<u>PART NO.</u>	<u>DESCRIPTION</u>	<u>QTY</u>
	55971	Gear Case – Assembly Mark series	
1	2564	Cap - Breather	1
2	6031	Plug - Pipe	2
3	20040	Cap Screw - 5/16 x 2	10
4	20711	Washer - Lock 5/16	10
5	27465	Bushing - Pipe	9
6	55974	Housing – Outboard, Mark series	1
7	38982	Housing - Inboard	1
8	37003	Gear - Pinion	2
9	38981	Gear	1
10	38978	Gasket	1
11	37006	Seal - Oil	1
12	37007	Bearing	2
13	37008	Bearing	4
14	20431	Screw - Set 5/16 x 3/4 Lock	1
15	38979	Washer	2
16	38980	Screw - Allen Head	1



Please Give Part No., Description and Unit Serial No.

97373-D

GEAR CASE – DUAL PINION



STYLE I

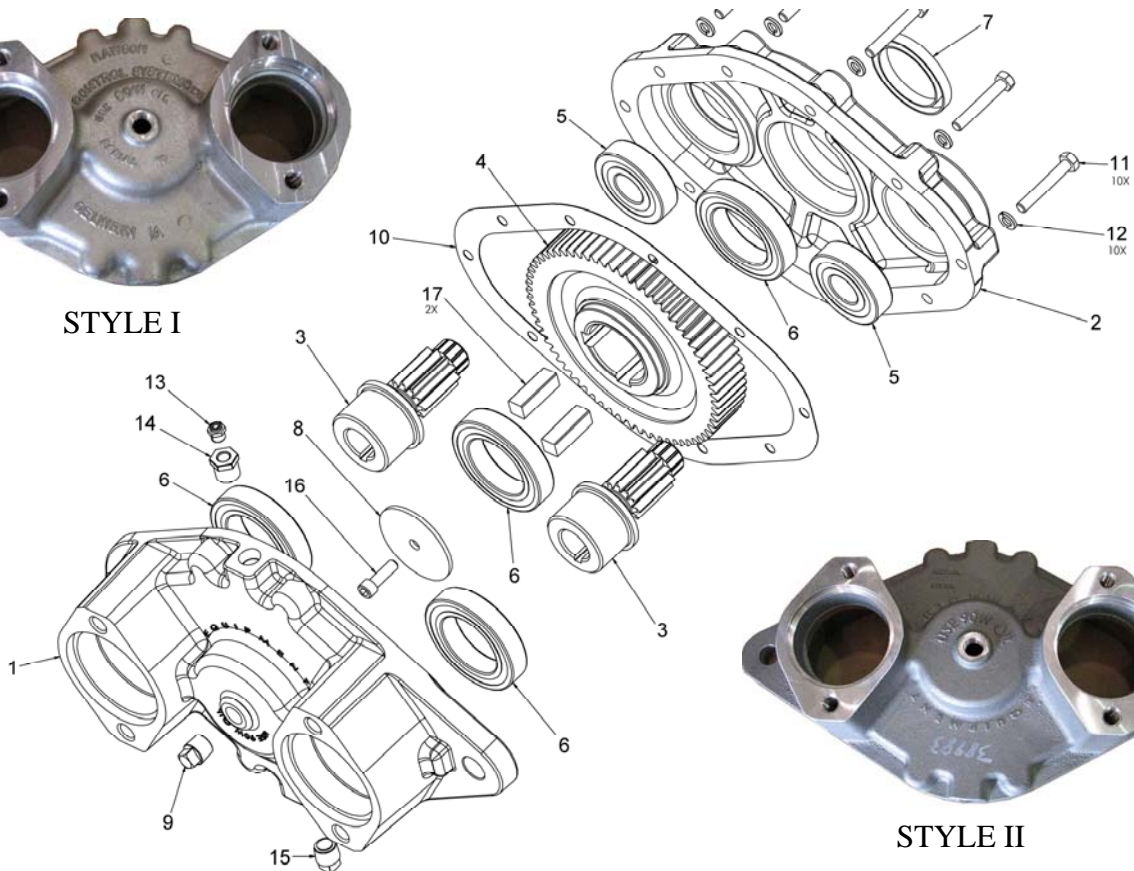

STYLE II

<u>ITEM</u>	<u>PART NO.</u>		<u>DESCRIPTION</u>	<u>QTY</u>
	37985		Gear Case – Assembly Dual Pinion	
	Style I	Style II	Parts – Service, Includes 1–17	
	304268-AA	304268-AB		
1	38983	304557	Housing – Outboard	1
2	38982	304558	Housing – Inboard	1
3	37003	304561	Gear – Pinion 11 Tooth	2
4	38981	304562	Gear – Driven 67 Tooth	1
5	37007	37007	Bearing	2
6	37008	37008	Bearing	4
7	37006	37006	Seal – Oil	1
8	38979	38979	Washer – Flat 2-1/2 x 11/32	2
9	6031	6031	Plug – Pipe	1
10	38978	304564	Gasket – Housing	1
11	20040	20040	Cap Screw – 5/16NC x 2	10
12	20711	20711	Washer – Lock 5/16	10
13	2564	2564	Cap – Breather	1
14	27465	27465	Bushing – Pipe 1/8 x 3/8	1
15	21490	21490	Plug – Pipe Magnetic	1
16	38980	38980	Screw – Allen Head 5/16-18 x 1	1
17	37010	37010	Key – 1/2 x 1/2 x 1-1/2	2



Please Give Part No., Description and Unit Serial No.

97373-D

SPINNER MOTOR

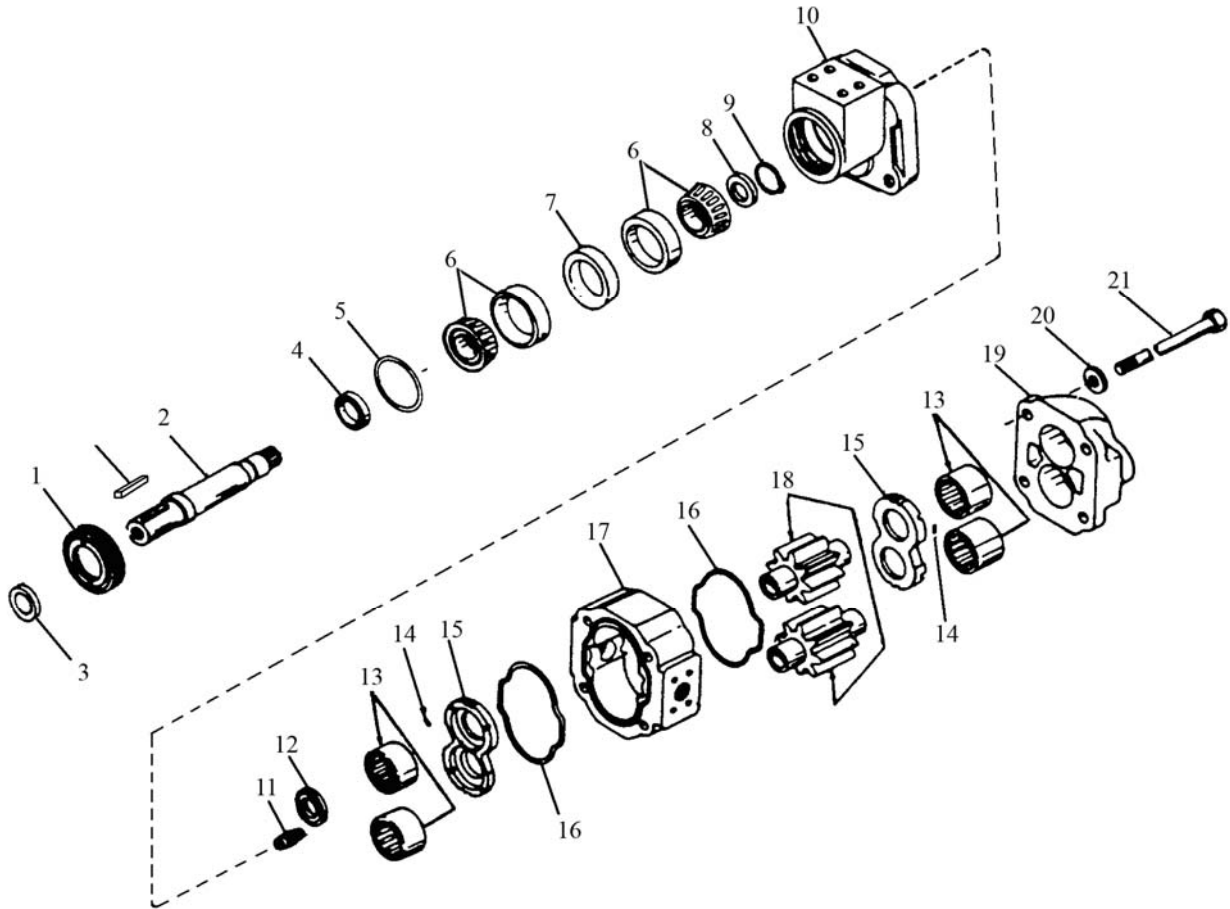

Please Give Part No., Description and Unit Serial No.

SPINNER MOTOR CONTINUED

<u>ITEM</u>	<u>PART NO.</u>	<u>DESCRIPTION</u>	<u>QTY</u>
	305944	Motor Assembly	
	72548	Kit – Seal, Includes Items 3-5	
	305824	Retainer – Assy w/Seals, Includes 1,3-5	
	306093	Shaft – Assy Output, Includes: 1-9, 22	
1	306091	Ring - Retainer	1
2	306088	Shaft	1
3	33809	Seal - Excluder	1
4	71980	Seal	1
	23940	Tool Seal Installation (Required to Install Item 4)	
5	28494	“O” Ring	1
6	28491	Bearing – Tapered Roller Assembly	2
7	28454	Spacer	1
8	306092	Washer - Lock	1
9	306089	Nut – lock	1
10	306087	Cover – Shaft End	1
11	58797	Plug	2
12	28495	Bushing	1
13	23806	Bearing	4
14	23819	Seals - Pocket (Makes 12 Seals)	1
15	23818	Plate	2
16	23820	Gasket	2
17	28498	Housing	1
18	23822	Set - Gear	1
19	23812	Cover - Port End	1
20		Washer	4
21	23833	Cap Screw	4
22	24458	Key	1
23	*30723	Tool – Wrench Spinner	1
24	*24536	Tool – Seal Driver	1
25	*23940	Tool – Seal Sleeve	1
26	*306090	Sleeve – Speedi	1

* - Not Shown



Please Give Part No., Description and Unit Serial No.

97373-D

CONVEYOR MOTOR

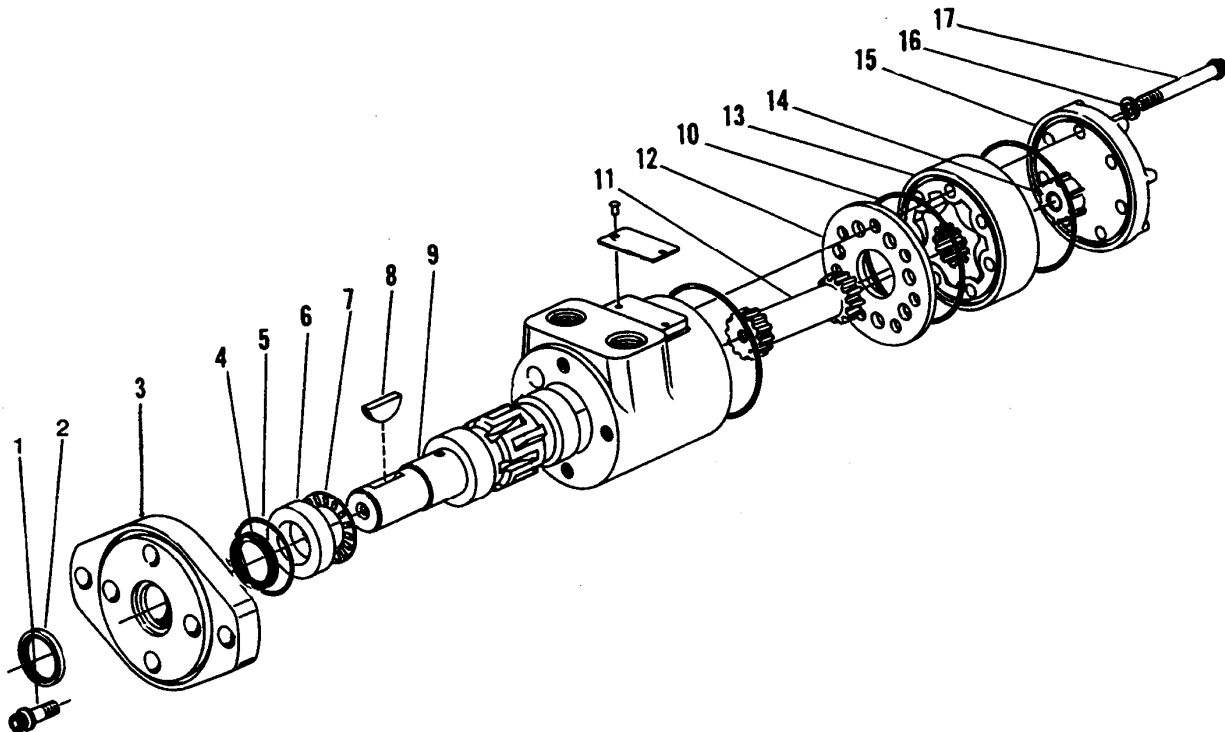

<u>ITEM</u>	<u>PART NO.</u>	<u>DESCRIPTION</u>	<u>QTY</u>
	55970	Motor - Hydraulic, 1"	
	55972	Motor - Hydraulic, 1" Modified	
	82459	Motor - Hydraulic, 1 1/4"	
	82462	Motor - Hydraulic, 1 1/4" Modified	
	38897	Motor - Hydraulic, 1 1/2"	
	46395	Motor - Hydraulic, 1 1/2" Modified	
	38898	Motor - Hydraulic, 2"	
	46396	Motor - Hydraulic, 2" Modified	
1	30665	Cap Screw - 5/16 x 7/8	4
2	73471	Seal	1
3	73555	Flange - Mounting (Used on Standard Motors)	1
	73556	Flange - Mounting (Used on Modified Motors)	1
4	73473	Seal	1
5	73474	Seal - "O" Ring	1



Please Give Part No., Description and Unit Serial No.

97373-D

CONVEYOR MOTOR CONTINUED

<u>ITEM</u>	<u>PART NO.</u>	<u>DESCRIPTION</u>	<u>QTY</u>
6	37385	Race - Bearing	1
7	37401	Bearing - Thrust Needle	1
8	3065	Key	1
9	37386	Shaft - Output Keyed	1
10	73480	Seal - "O" Ring	3
11	47062	Drive (Used on 1" Motors)	1
	83014	Drive (Used on 1 1/4" Motors)	1
	16946	Drive (Used on 1 1/2 & 2" Motors)	1
12	37388	Plate - Spacer	1
13	47063	Gerotor - 1"	1
	83015	Gerotor - 1 1/4"	1
	37394	Gerotor - 1 1/2"	1
	37395	Gerotor - 2"	1
14	47064	Spacer - 1"	1
		* No Spacer (Item 14) on 1 1/4" Motor	
	37398	Spacer - 1 1/2"	1
	37399	Spacer - 2"	1
15	37400	Cap - End	1
16	37381	Washer - Seal	7
17	47065	Cap Screw (Used on 1" Motors)	7
	83016	Cap Screw (Used on 1 1/4" Motors)	7
	16937	Cap Screw (Used on 1 1/2" Motors)	7
	16938	Cap Screw (Used on 2" Motors)	7
18	* 73477	Seal - "O" Ring	1
19	* 73472	Washer - Back-up	1
	39137	Seal Kit (Includes Items 2,4,5,10,16,18 & 19)	



SPINNER CONTROL VALVE

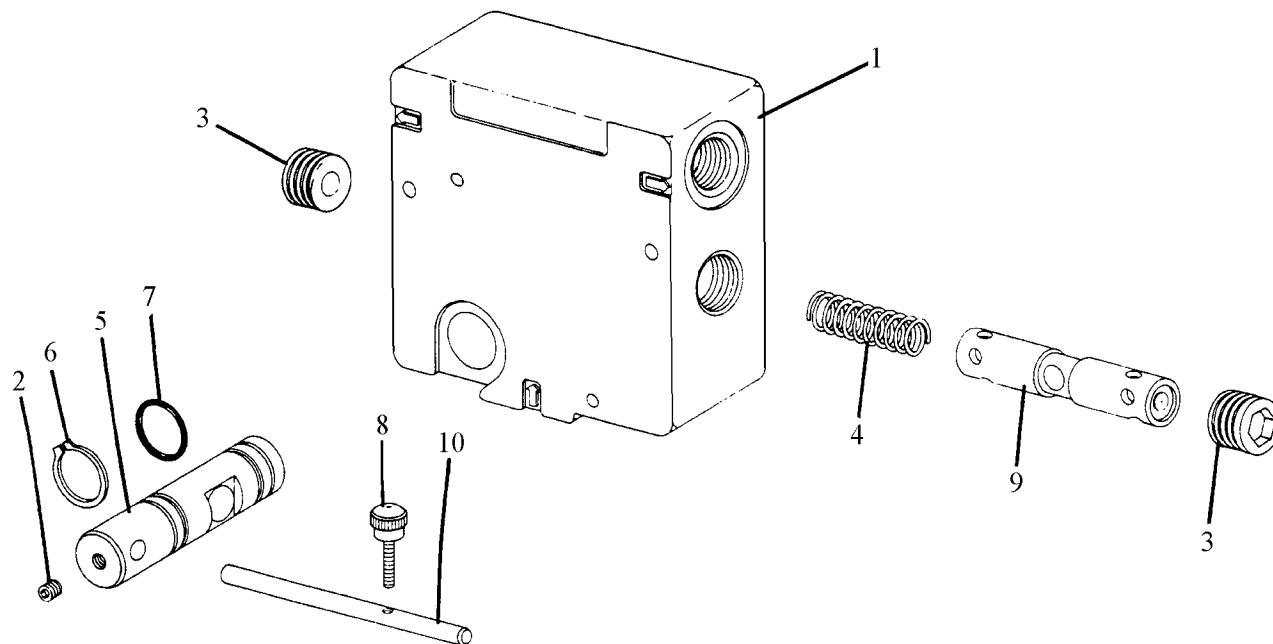

<u>ITEM</u>	<u>PART NO.</u>	<u>DESCRIPTION</u>	<u>QTY</u>
	32485	Valve - Hydraulic	
1	N.S.	Body - Adjustable Divider	1
2	20735	Screw - Set, 1/4 x 1/4	1
3	24555	Plug	2
4	24556	Spring	1
5	24557	Spool - Rotary	1
	28474	Kit - Seal (Includes Items 6 & 7)	1
6	24559	Ring - Snap	2
7	24563	O-Ring	2
8	24566	Screw - Thumb	1
9	56367	Spool - Compensating	1
10	24558	Handle	1

N.S. - Not Serviced Separately



Please Give Part No., Description and Unit Serial No.

97373-D

LIGHTS

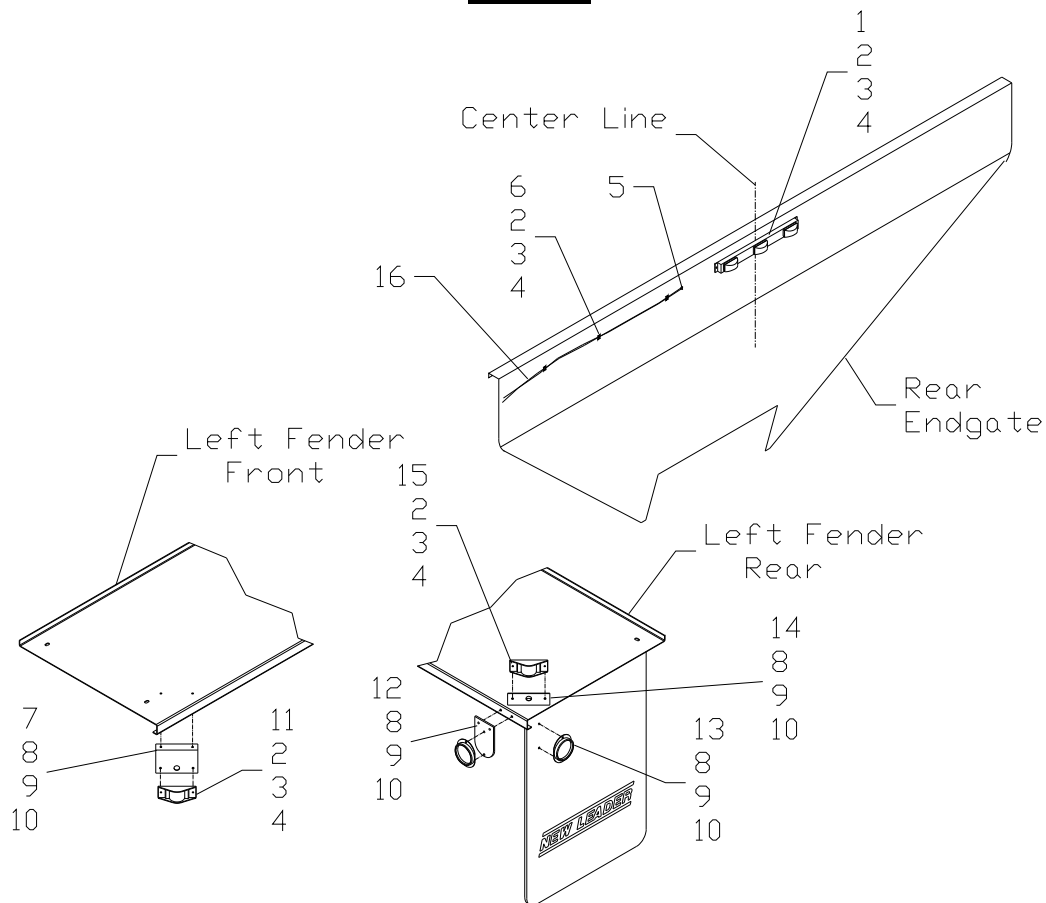

<u>ITEM</u>	<u>PART NO.</u>	<u>DESCRIPTION</u>	<u>QTY</u>
1	6114	Cluster - Light, Red	1
2	20572	Screw - Machine 3/16 x 3/4	33
3	20709	Washer - Lock 3/16	33
4	20641	Nut - Hex 3/16	33
5	21986	Grommet - Rubber	AR
6	6198	Clamp - Wire	AR
7	38611	Bracket - Front Light, Amber	2
8	20003	Cap Screw - 1/4 x 3/4	24
9	20691	Washer - Flat 1/4	24
10	20642	Nut - Hex 1/4	24
11	6108	Clearance Lamp - Amber	2
12	3824	Mount - Belt Reflector	4
13	6107	Reflector - Red	4
14	3775	Bracket - Rear Light, Red	2
15	6110	Clearance Lamp - Red	2
16	21580	Wire - 14 Gauge, Black	Inches AR

AR - As Required



Please Give Part No., Description and Unit Serial No.

97373-D

DECALS

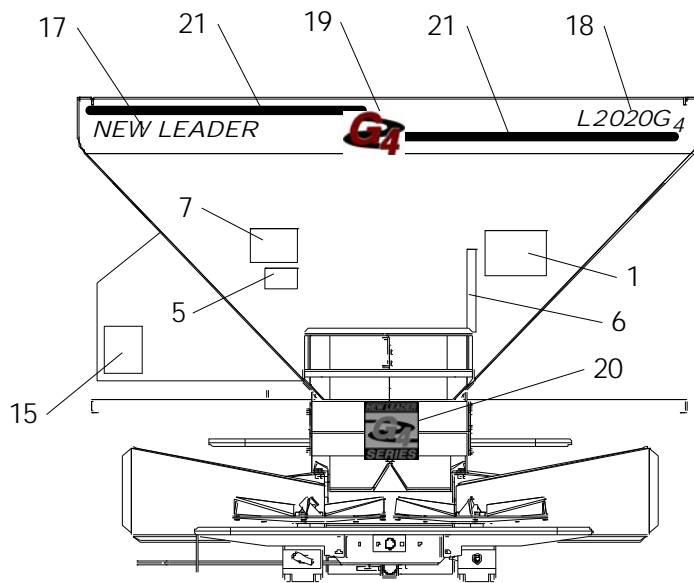
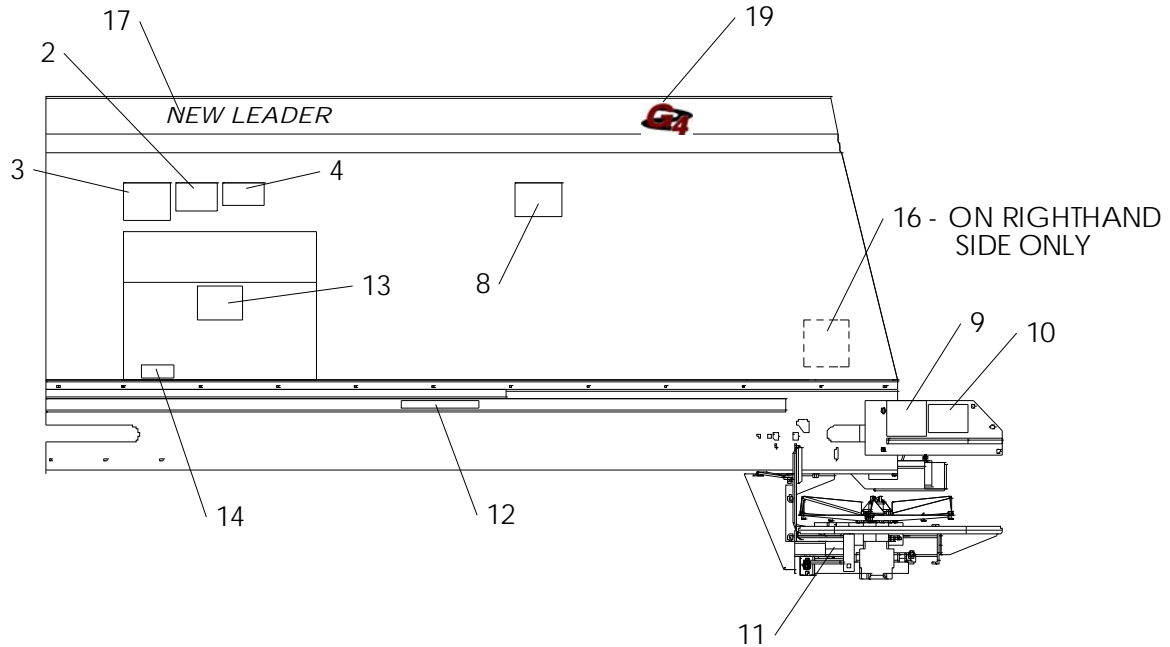

Please Give Part No., Description and Unit Serial No.

97373-D

DECALS CONTINUED

<u>ITEM</u>	<u>PART NO.</u>	<u>DESCRIPTION</u>	<u>QTY</u>
1	368	Decal - Flying Material	1
2	364	Decal - Warning, Stay Out of Box	2
3	150034	Decal - Caution, Improper Operation	1
4	321	Decal - Caution, Material to be Spread	1
5	6541	Decal - Oil Lube Chart	1
6	23769	Decal - Feedgate Slide Scale	1
7	71526	Decal - Notice, Adjust Spinner	1
8	39138	Decal - Warning, Hot Components	1
9	55630	Decal - Warning, No Step	2
10	55631	Decal - Warning, Guard is for Your Protection	2
11	87110	Decal - Scale Spinner	1
12	39200	Decal - Fender Capacity	2
13	8665	Decal - Caution, Hydraulic Oil Only	1
14	8664	Decal - Caution, Keep Valve Open	1
15	39378	Decal - Filter	1
16	21477	Decal - Notice, Conveyor Chain Life	1
17	87164	Decal - New Leader, Black	3
	87165	Decal - New Leader, White	3
18	87126	Decal - L2020G4, Black	1
	87127	Decal - L2020G4, White	1
19	87122	Decal - G4 Black/Red	3
	87129	Decal - G4 Black/White	3
	87123	Decal - G4 White/Red	3
20	87109	Decal - G4	1
21	87163	Decal - Striping White	AR
	87162	Decal - Striping Black	AR
	31736	Paint - Touch Up, New Leader Red	AR
	31740	Paint - Touch Up, White	AR



Please Give Part No., Description and Unit Serial No.

MARK V CONTROL VALVE ASSEMBLY - CONTROL VALVE/GEAR CASE

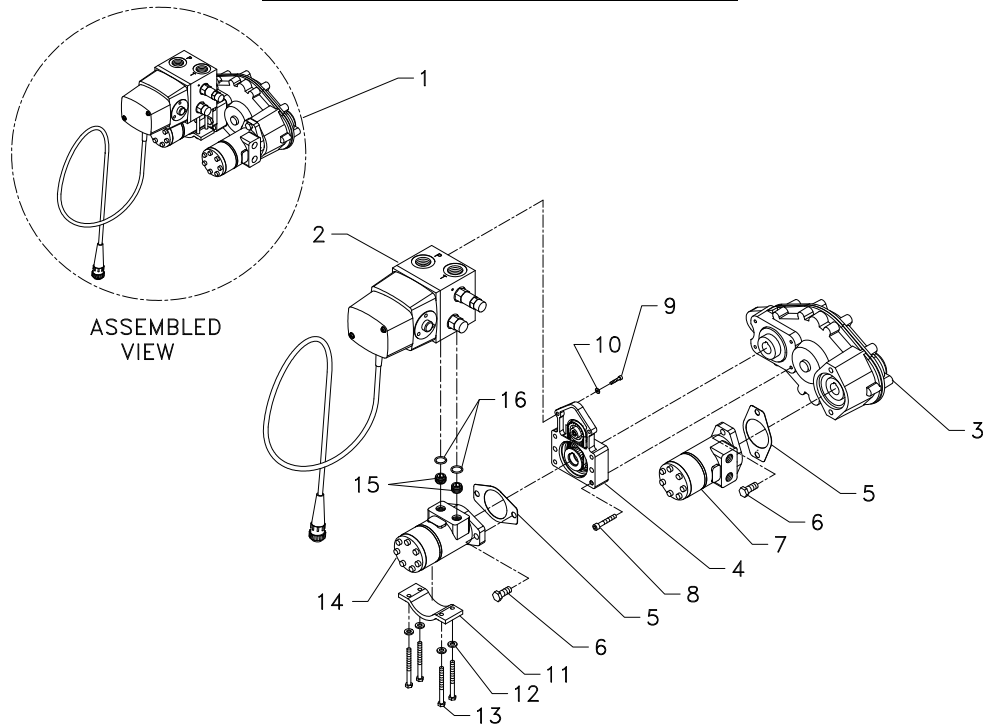

<u>ITEM</u>	<u>PART NO.</u>	<u>DESCRIPTION</u>	<u>QTY</u>
1	88378	Control Valve/Dual Gear Case, 1 1/4 Motors Assy	1
	* 88376	Control Valve/Single Gear Case, 1 1/2 Motor Assy	1
2	89758	Valve Assembly	1
3	55971	Gear Case <input type="checkbox"/> Dual	1
	43501	Gear Case - Single	1
4	84940	Valve Adapter Kit	1
5	74524	Gasket	2
6	44442	Cap Screw	4
7	82459	Motor - Hydraulic 1 1/4 Dual Gear Case Only	1
8	44456	Screw - Socket Head	2
9	44454	Screw - Socket Head	2
10	20724	Washer - Seal	2
11	47276	Saddle - Motor	1
12	36419	Washer	4
13	47277	Cap Screw	4
14	82462	Motor - Hydraulic 1 1/4 Modified, Dual Gear Case	1
	* 46395	Motor - Hydraulic 1 1/2, Single Gear Case	1
15	44409	Port Adapter	2
16	29854	O-Ring	2
17	306890	Breather Tube - Assembly Gear Case	1
	306891	Fitting - 4-2 630202K	1
	9005-0-7661	Tubing - 1/4 OD Air Brake	Feet 1.5

* - Not Shown



Please Give Part No., Description and Unit Serial No.

97373-D

MARK SERIES CONTROL VALVE ASSEMBLY – VALVE ADAPTER

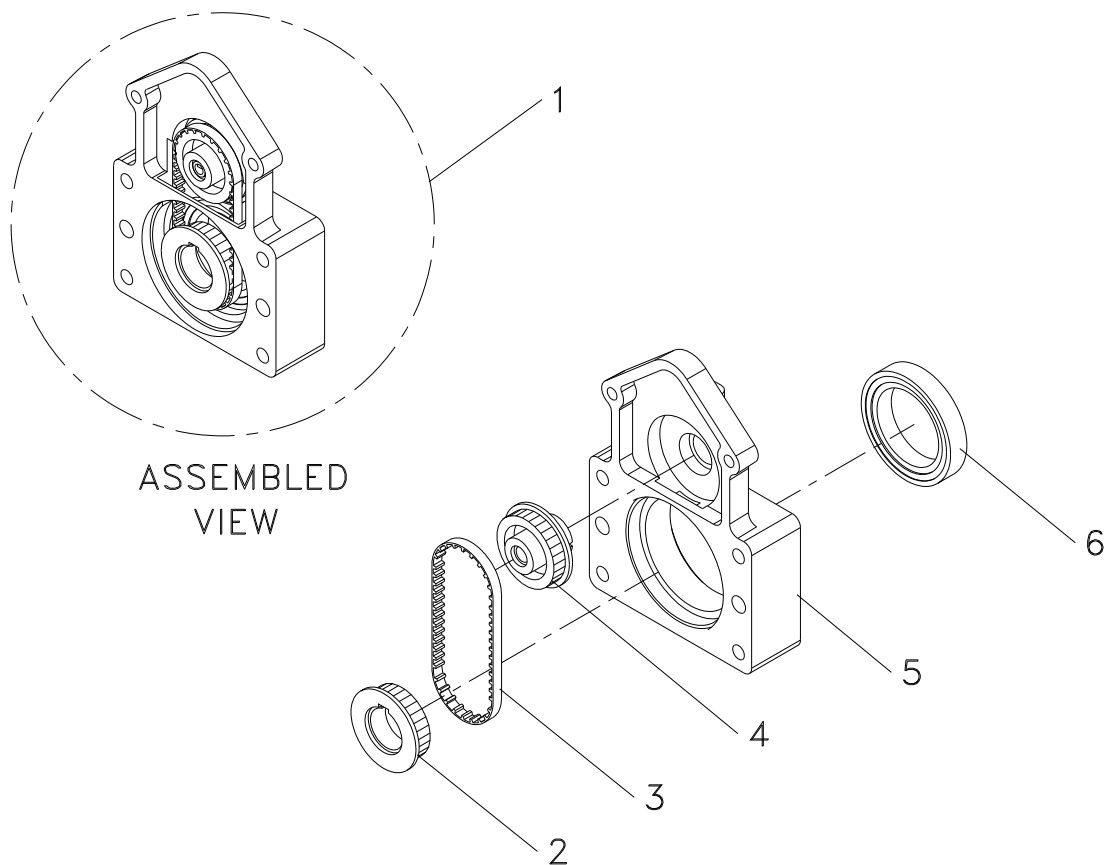

<u>ITEM</u>	<u>PART NO.</u>	<u>DESCRIPTION</u>	<u>QTY</u>
1	84940	Valve Adapter Kit	1
2	44440	Pulley – Drive	1
3	44439	Belt – Timing	1
4	84941	Pulley – Timing	1
5	84942	Adapter	1
6	44445	Seal	1

MARK V CONTROL VALVE ASSEMBLY - VALVE

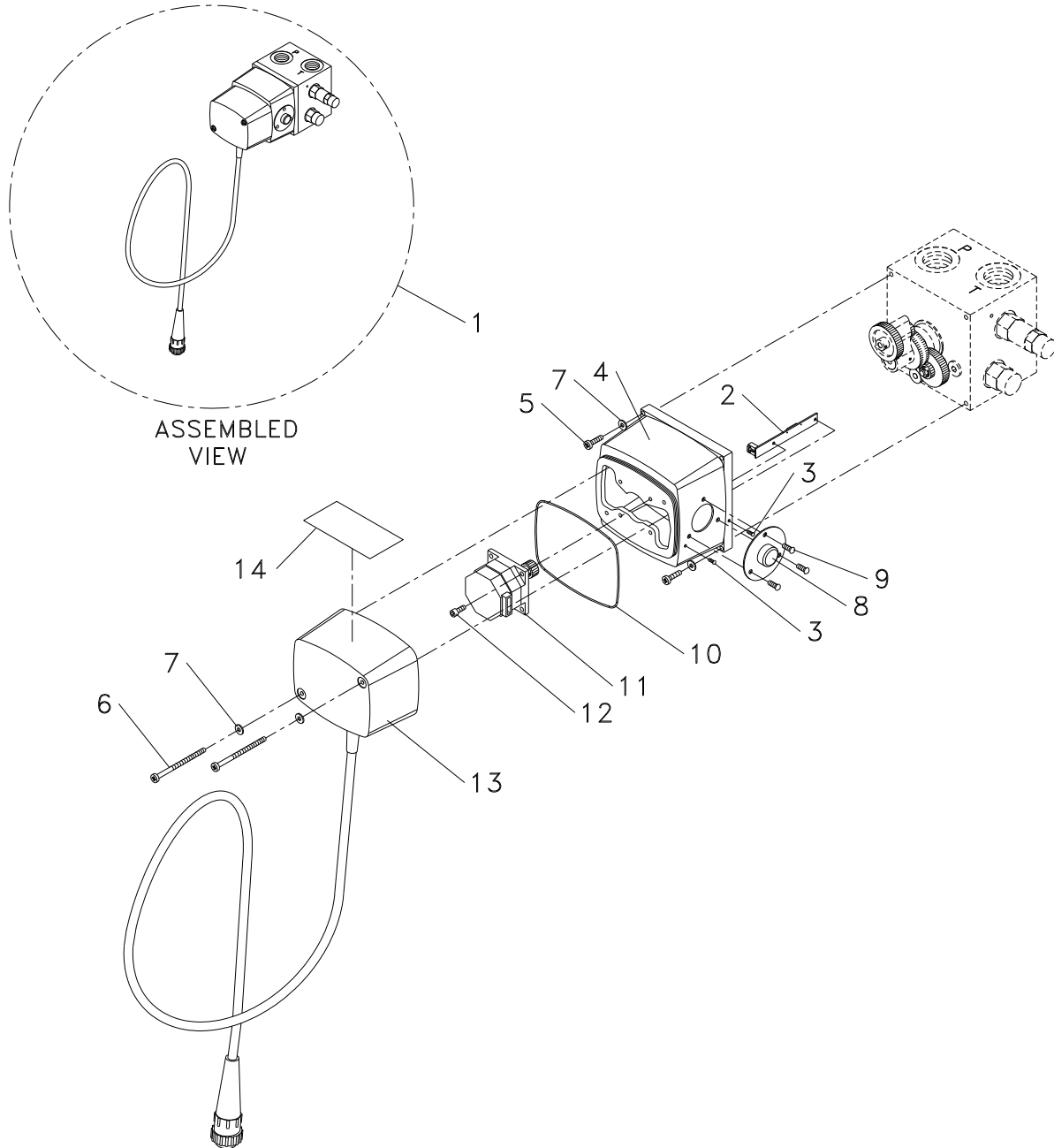

Please Give Part No., Description and Unit Serial No.

97373-D

**MARK V CONTROL VALVE ASSEMBLY –
VALVE CONTINUED**

<u>ITEM</u>	<u>PART NO.</u>	<u>DESCRIPTION</u>	<u>QTY</u>
1	89758	Valve Assembly	1
2	84934	Reed Switch Board	1
3	84935	Bolt	2
4	84936	Housing	1
5	44483	Screw – Machine	4
6	83645	Screw – Machine	1
7	20724	Washer – Seal	6
8	84937	Cover – Service Assembly	1
9	84938	Bolt – O-Ring	3
10	13207	Seal – O-Ring	1
11	83642	Motor Assembly	1
12	83643	Screw – Socket Head	4
13	84939	Cap Assembly	1
14	96451	Decal – Mark V	1



Please Give Part No., Description and Unit Serial No.

97373-D

MARK SERIES CONTROL VALVE ASSEMBLY -IDLER

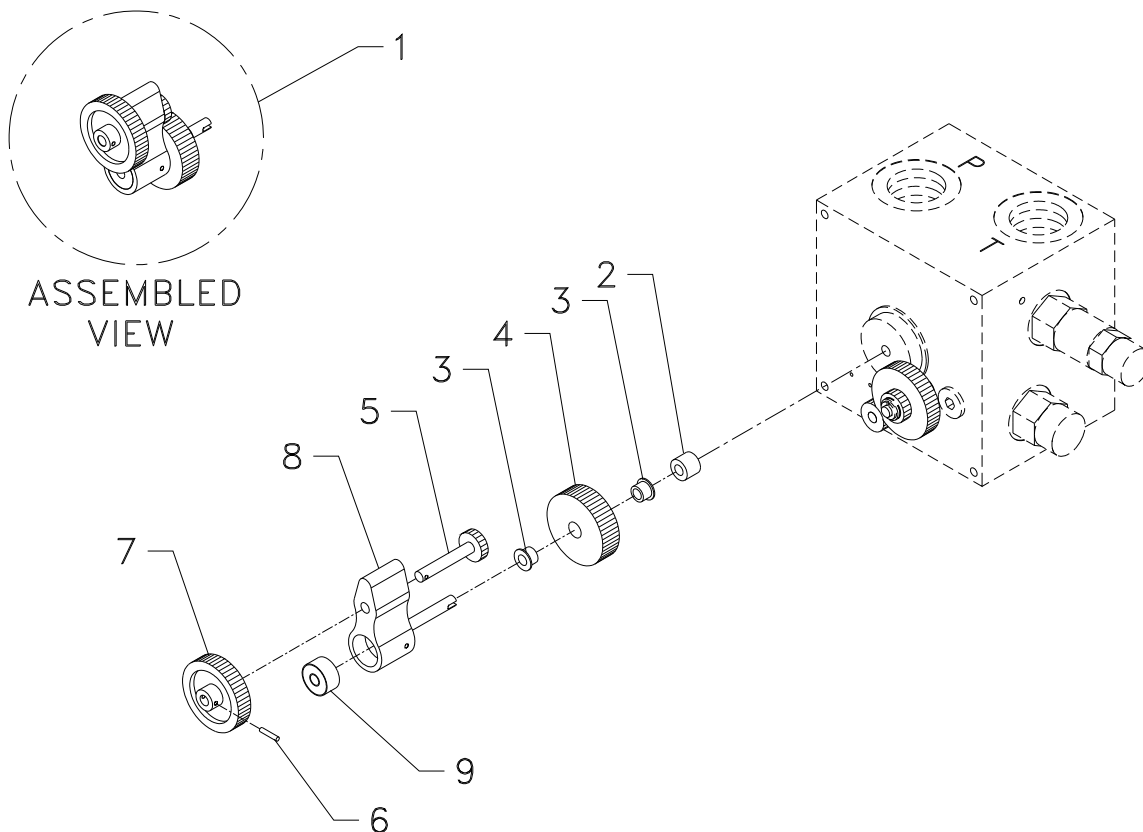

<u>ITEM</u>	<u>PART NO.</u>	<u>DESCRIPTION</u>	<u>QTY</u>
1	83640	Idler Assembly	1
2	44431	Spacer	1
3	44433	Bushing	2
4	44434	Gear - Resolve	1
5	44428	Gear Assembly	1
6	44461	Pin - Roll	1
7	44432	Gear	1
8	44429	Idler Arm Assembly, Includes Item 9	1
9	44435	Bearing	1



Please Give Part No., Description and Unit Serial No.

MARK V CONTROL VALVE ASSEMBLY - VALVE BLOCK

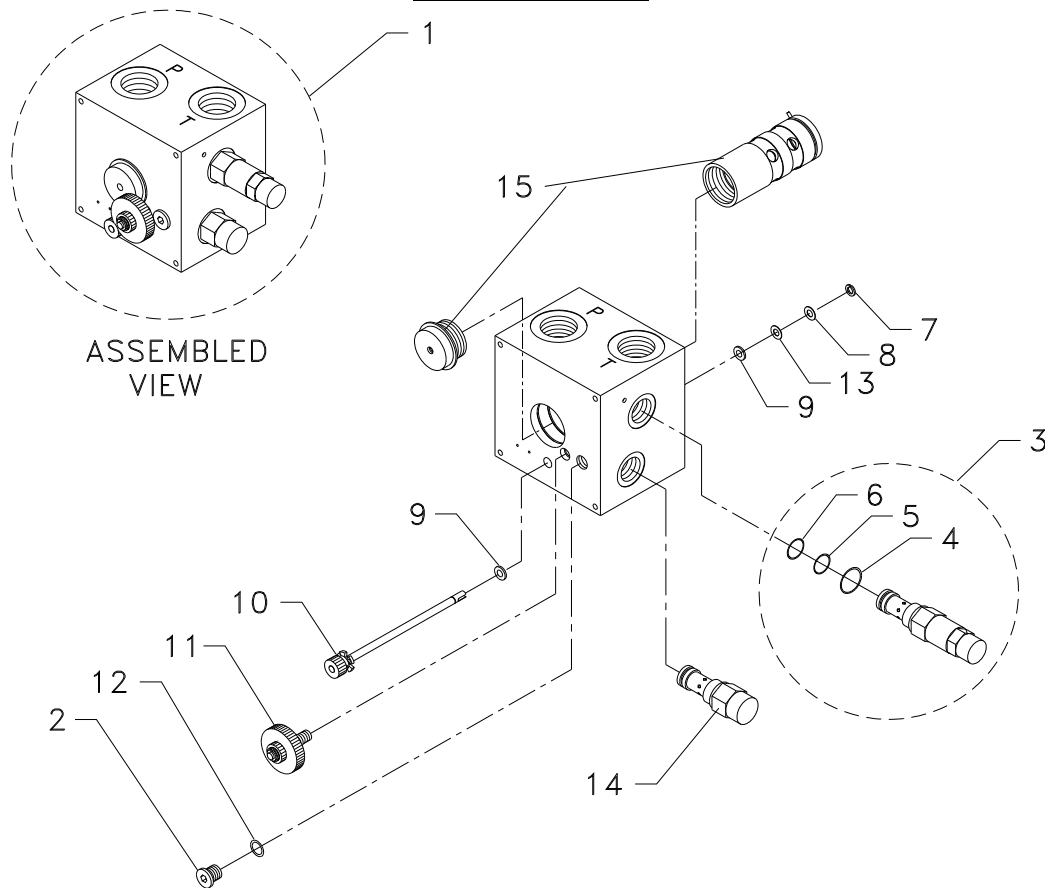

<u>ITEM</u>	<u>PART NO.</u>	<u>DESCRIPTION</u>	<u>QTY</u>
1	89759	Block – Valve Assembly	1
2	83627	Plug	1
3	83623	Valve – Relief Assembly	1
4	83624	O-Ring	1
5	83632	Ring – Back-up	1
6	83625	O-Ring	1
7	44464	Ring – Snap	1
8	44449	Shim – Nylon	1
9	84944	Bearing	2
10	84945	Shaft – Input Assembly	1
11	83636	Gear – Idler Assembly	1
12	83626	O-Ring	1
13	36423	Washer – Flat .25 SS	1
14	89769	Cartridge – Check	1
15	89760	Cartridge – Metering, Spool/Liner & Nut	1
	88887	O-Ring – Kit Service	1



Please Give Part No., Description and Unit Serial No.

97373-D