



**Guardian L3030G4
MULTAPPLIER
Operator's Manual**

UNIT SERIAL NUMBER _____

INSERT SERIAL NUMBER _____

MANUAL NUMBER: 307369-AA-G

EFFECTIVE 12/2018



1330 76TH AVE SW
CEDAR RAPIDS, IA 52404-7052
PHONE (800) 363-1771 | FAX (319) 286-3350
www.newleader.com

Copyright 2019 Highway Equipment Company, Inc.
Now doing business as New Leader Manufacturing

Table of Contents

- Interactive Features 4
- Preface 7
- Safety 8
 - Important Safety Information 8
 - Safety Alert Symbols 8
- General Safety Rules 9
- Safety Decals..... 19
- Installation 25
 - Hydraulic Requirements..... 25
 - Lifting the Spreader 25
 - Installing Body 26
 - Electrical Connections 26
 - Hydraulic Hose Installation..... 26
 - Hydraulic Hose Installation Guide 27
- Insert Installation..... 28
 - Spreader Preparation..... 28
 - Feedgate Adjustment..... 30
 - Insert Installation 31
 - Hydraulics..... 34
 - Hydraulic Installation..... 34
 - Hillside Divider & Conveyor Cover 35
 - Electrical Connections 36
 - Insert Removal/Endgate Installation..... 36
- General Description 37
- Introduction..... 38
- Dimensions & Capacities 41
- Initial Startup..... 44
 - G4 Spinner Squaring..... 45
- Field Testing..... 49
- General Operating Procedures 50
- Lubrication & Maintenance..... 51
 - Preventative Maintenance Pays! 51
 - Hydraulic System 51
 - Hydraulic Hose 52
 - #5 Straight Belt Conveyor..... 52
 - Maintenance 52
 - Adjustment 53
 - Belt Shields 56
 - Removal & Replacement 56
 - #4 Conveyor Chain - Bin 2 58
 - Conveyor Gearcase 59
 - Bin Sensor 59
 - Lubrication of Bearings..... 59
 - Fasteners..... 59
 - Clean-Up 59

Table of Contents

Lubricant & Oil Specifications	61
Hydraulic System	61
Gearcase Lubricant	61
Grease Gun Lubricant	61
Chain Conveyors	61
Lubrication & Maintenance Chart	62
Troubleshooting.....	64
Standard Torques.....	66
Pre- & Post-Season Checklists.....	67
Hydraulics.....	69
Hydraulic Schematics	69
Spread Pattern.....	75
Crushing Strength	75
SGN	75
Product Setup Guidelines.....	76
Crush Test	77
SGN Scale Test	78
Spread Pattern Test Kit	81
Spinners	82
Spreader Preparation.....	82
Test Procedure.....	83
Test Results	85
Troubleshooting	86
Determining Driving Centers	87
Verifying Driving Centers.....	88

NOTE:

This manual incorporates several interactive features to provide supplemental information and ease of navigation. The information below is to aid in the identification and use of these features.

Hyperlinks

Hyperlinks provide direct access to a specific destination when clicked. The entire Table of Contents of this manual is hyperlinked to provide quick access to all sections of this manual when viewing the electronic version.

Hyperlinks within the content are denoted by **blue, bold underlined text**. Electronic format viewers can click these links for direct access to New Leader online features. Internet access is required.

Quick Reference (QR) Codes

Quick reference codes provide direct access to a specific destination when activated. An example is provided below. In the printed version of this manual, viewers may scan the codes with a supporting mobile device for direct access to New Leader online features. Mobile data is required.

The electronic version of this manual provides the option to scan codes on-screen, or to click the code like a button. Internet access/mobile data is required.



Click or Scan - NewLeader.com

This page is intentionally left blank.

Insert Current New Leader Warranty

PLEASE ! ALWAYS THINK SAFETY FIRST !!

The purpose of this manual is to familiarize the person (or persons) using this unit with the information necessary to properly install, operate, and maintain this system. The safety instructions indicated by the safety alert symbol in the following pages supersede the general safety rules. These instructions cannot replace the following: the fundamental knowledge that must be possessed by the installer or operator, the knowledge of a qualified person, or the clear thinking necessary to install and operate this equipment. Since the life of any machine depends largely upon the care it is given, we require that this manual be read thoroughly and referred to frequently. If for any reason you do not understand the instructions, please call your authorized dealer or our Product Sales and Support Department at 1-888-363-8006.

It has been our experience that by following these installation instructions, and by observing the operation of the spreader, you will have sufficient understanding of the machine enabling you to troubleshoot and correct all normal problems that you may encounter. Again, we urge you to call your authorized dealer or our Product Sales and Support Department if you find the unit is not operating properly, or if you are having trouble with repairs, installation, or removal of this unit.

We urge you to protect your investment by using genuine HECO parts and our authorized dealers for all work other than routine care and adjustments.

Highway Equipment Company reserves the right to make alterations or modifications to this equipment at any time. The manufacturer shall not be obligated to make such changes to machines already in the field.

This Safety Section should be read thoroughly and referred to frequently.

ACCIDENTS HURT !!!

ACCIDENTS COST !!!

ACCIDENTS CAN BE AVOIDED !!!

IMPORTANT SAFETY INFORMATION

Figure 1.1 - The need for safety cannot be stressed strongly enough in this manual. At Highway Equipment Company, we urge you to make safety your top priority when operating any equipment. We firmly advise that anyone allowed to operate this machine carefully read, learn and understand all messages and information in this manual and on machine's safety decals before operating machine, as well as familiarize themselves with the location and function of all machine controls.

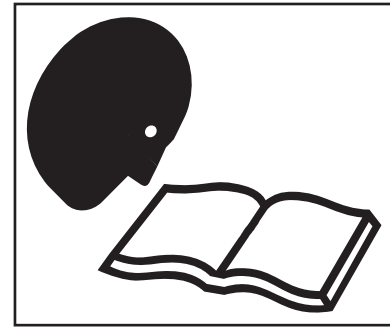

Figure 1.1

The following guidelines are intended to cover general usage and to assist you in avoiding accidents. There will be times when you will run into situations that are not covered in this section. At those times the best standard to use is common sense. If, at any time, you have a question concerning these guidelines, please call your authorized dealer or our Product Sales & Support Department at (800) 363-1771.

SAFETY ALERT SYMBOLS



TAKE NOTE! THIS SAFETY ALERT SYMBOL FOUND THROUGHOUT THIS MANUAL IS USED TO CALL YOUR ATTENTION TO INSTRUCTIONS INVOLVING YOUR PERSONAL SAFETY AND THAT OF OTHERS. FAILURE TO FOLLOW THESE INSTRUCTIONS CAN RESULT IN INJURY OR DEATH.

In this manual and on the safety signs placed on the unit, the words "DANGER," "WARNING," "CAUTION," and "NOTICE" are used to indicate the following:



Indicates an imminently hazardous situation that, if not avoided, WILL result in death or serious injury. This signal word is to be limited to the most extreme situations and typically for machine components that, for functional purposes, cannot be guarded.



Indicates a potentially hazardous situation that, if not avoided, COULD result in death or serious injury, and includes hazards that are exposed when guards are removed. It may also be used to alert against unsafe practices.



Indicates a potentially hazardous situation that, if not avoided, MAY result in minor or moderate injury. It may also be used to alert against unsafe practices.

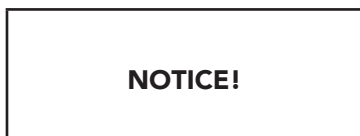

Is used for informational purposes in areas which may involve damage or deterioration to equipment but generally would not involve the potential for personal injury.

NOTE:

Provides additional information to simplify a procedure or clarify a process.

Operations

PREPARE FOR EMERGENCIES

Figure 1.2 - Be prepared if a fire starts. Keep a fully charged fire extinguisher and first aid kit in accessible place on the vehicle at all times.

Fire extinguisher must be Type ABC or Type BC.

Keep emergency numbers for doctors, ambulance service, hospital and fire department available at all times.



Figure 1.2

INSPECT HARDWARE BEFORE USE

Figure 1.3 - Inspect all bolts, screws, fasteners, keys, chain drives, body mounts and other attachments periodically. Immediately replace any missing or damaged parts immediately with proper specification parts.

Inspect spinner fins, spinner frame mounting and spinner fin hardware daily. Look for missing or loose fasteners, wear and cracks. Replace immediately if needed. Use only new SAE grade 5 or grade 8 screws and self-locking nuts.

Tighten all bolts, nuts and screws to specified torques. Refer to "Standard Torques" in Maintenance section of this manual.

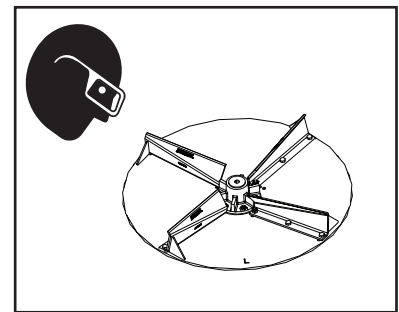

Figure 1.3

HANDLE FLAMMABLE MATERIALS SAFELY

Figure 1.4 - Handle fuel and hydraulic oil with care. They are highly flammable.

Always stop the engine before refueling machine or filling hydraulic reservoir.

Never smoke while adding fuel or oil to machine. Add fluids in a safe place away from open flame and sparks.

Do not allow overflow. Clean up spilled fuel and oil immediately.

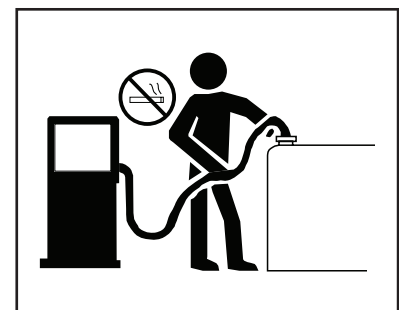

Figure 1.4

Always have a multipurpose dry chemical fire extinguisher filled and available during machine operation and when adding fuel. Know how to use it.

General Safety Rules

Operations

HANDLE HAZARDOUS MATERIALS SAFELY

Figure 1.5 - Materials to spread can be dangerous.

Improper selection, application, use or handling may be a hazard to persons, animals, plants, crops or other property.

A Safety Data Sheet (SDS) provides specific details on chemical products: physical and health hazards, safety procedures and emergency response techniques.

Check the SDS before starting any job using a hazardous material. Follow all instructions and precautions given by the material manufacturer.



Figure 1.5

WORK IN WELL-VENTILATED AREAS



WARNING

Never run machine engine inside a building unless adequate ventilation is provided to safely and properly remove exhaust fumes.

Figure 1.6 - Always work in a properly ventilated area.

Engine exhaust fumes can cause sickness or death. If it is necessary to run an engine in an enclosed area, use proper equipment to safely remove exhaust fumes from the working area.

Open building doors and get fresh air into the working area whenever possible.



Figure 1.6

PROTECT AGAINST NOISE

Figure 1.7 - Long periods of exposure to high decibels or loud noise can cause hearing impairment or loss.

Wear proper hearing protection during periods of exposure to high decibels or loud noise.

Wear a proper hearing protective device such as earmuffs or earplugs to protect against high decibels and / or uncomfortable loud noises.

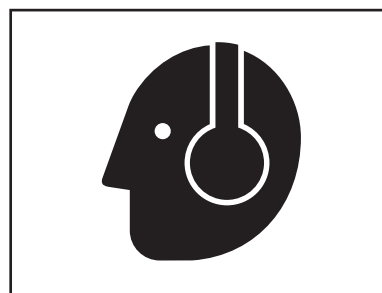

Figure 1.7

AVOID MOVING PART HAZARDS

Figure 1.8 - Entanglement in rotating drive lines or moving parts will cause serious injury or death.

Stay clear of all moving parts, such as shafts, couplings and universal joints.

Make sure all personnel are clear of machine before starting.



Figure 1.8

Figure 1.9 - Do not operate machine without all guards and shields closed and secured. Disconnect and lock out power source before removing guards.

Disconnect and lock out power source before adjusting or servicing.

Keep hands, feet, hair and clothing away from moving parts.

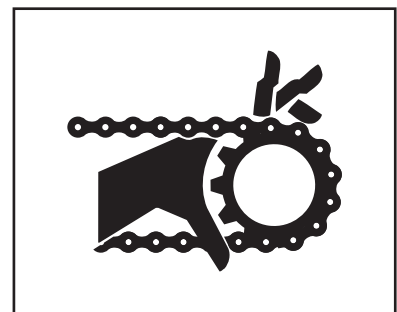

Figure 1.9

Figure 1.10 - Keep away from spinners while they are turning.

Rocks, scrap metal and other material can be thrown from the spinners violently. Stay away from discharge area.

Stop machine before servicing or adjusting. Wear eye protection.

Make sure discharge area is clear before spreading.

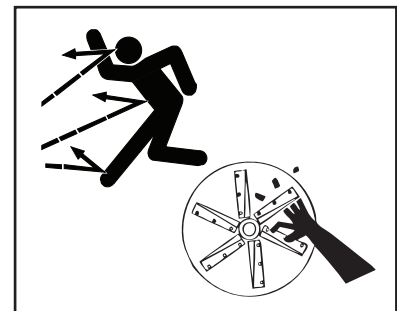

Figure 1.10

Figure 1.11 - Stay out of the spreader.

If it is necessary to enter the spreader, return to the shop, empty body, turn off all power, engage brakes, shut down engine and remove keys before entering.

Tag all controls to prohibit operation. Tags should only be placed, and later removed, by the person working in the body.

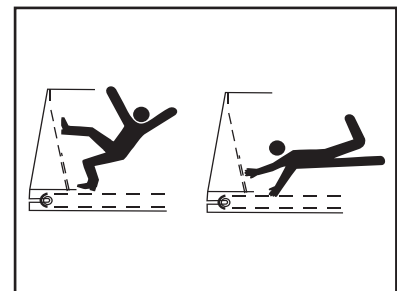

Figure 1.11

General Safety Rules

Operations

DO NOT CLIMB OR STAND ON MACHINE

Figure 1.12 - Never allow any personnel to ride in or on the machine.

Use only inspection ladder or portable ladder to view the unit. Use caution when getting on and off the ladder, especially in wet, icy, snowy or muddy conditions. Clean mud, snow and ice from steps and footwear.

Always maintain three-point contact with steps, ladders and handholds. Face the machine when mounting and dismounting inspection ladder. Do not jump off the machine.



Figure 1.12

OPERATE MACHINE SAFELY

Always walk around and visually inspect the machine before using. Check immediate vicinity of machine for people and obstructions. Ensure adequate visibility.

Avoid distractions such as reading, eating or operating personal electronics that take your attention away from operating the machine. Never operate the machine under the influence of alcohol, drugs or while otherwise impaired.

Always come to a complete stop before reversing. Be sure that all personnel are clear of machine path. Turn around and look directly for best visibility. Ensure all rear view mirrors are properly installed and adjusted. Use a signal person when backing if view is obstructed or when in close quarters.

Always disengage hydraulics before shutting down engine. DO NOT start engine with hydraulics engaged.

Handling & Transportation

TRAVELING & TRANSPORTING ON PUBLIC ROADS

Always walk around and visually inspect the machine before traveling on public roads. Check for damage and/or faulty components that can fail and create a hazard or unsafe condition. Make sure all machine systems operate properly, including but not limited to: headlights, tail and brake lights, hazard warning lights, turn indicators, parking brake, horn and rear view mirrors. Repair or replace any component that is not in proper working order.

Never drive machine at a speed that causes it to bounce or cause loss of control.

Obey all traffic safety laws and regulations. Operate the machine with hazard warning lights on, unless prohibited by law. It is the operator's responsibility to activate and use road lights properly while traveling on public roads.

Cover all loads that may spill or blow away. Environmental damage may result. Do not spread dusty materials where dust may create pollution, visibility issues or interfere with traffic on public roads.

When transporting equipment or machine on a trailer, ensure it is properly secured. Be sure that SMV signs on equipment or machine are covered while in transport on a trailer.

Be aware of overhead structures and power lines. Make sure machine can safely pass under. Refer to "Dimensions & Capacities" pages in the Operations section of this manual.

NAVIGATING ROUGH & UNEVEN TERRAIN

Figure 2.1 - Turn slowly and be careful when traveling on rough surfaces and side slopes. Avoid holes, ditches and obstructions that may cause machine to roll over, especially with a loaded spreader.

Never drive near the edge of a gully or steep embankment.

Load may shift, causing vehicle to tip.

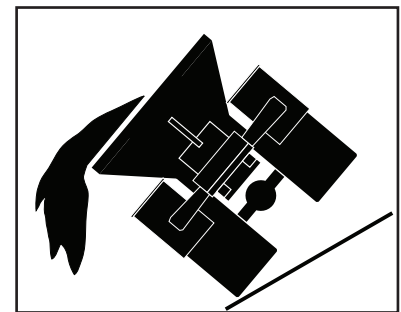

Figure 2.1

General Safety Rules

Maintenance

READ AND UNDERSTAND MAINTENANCE PROCEDURES

Figure 3.1 - Read the maintenance and safety instructions and understand them before performing any maintenance procedure.

Never perform any maintenance procedure or repair if the instructions and safety procedures are not fully understood. Only trained and qualified personnel should perform any maintenance procedure or repair.

Never modify any equipment or add attachments not approved by Highway Equipment Company.

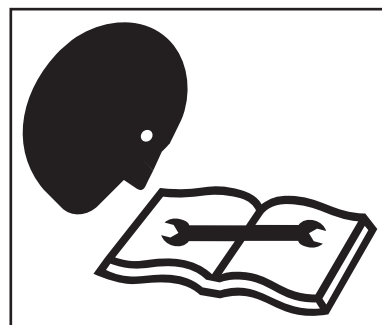

Figure 3.1

DO NOT SERVICE OR ADJUST MACHINE WHILE IN MOTION

Figure 3.2 - Never lubricate, service or adjust the machine or any of its components while they are moving.

Never wear loose clothing or jewelry when working near machine tools or moving parts.

Remove rings and other jewelry to prevent electrical shorts and other personal injury when in contact with machine tools or moving parts.

Close and secure all guards removed for service. Check all screws, bolts, nuts and fasteners for proper torques before operating machine.

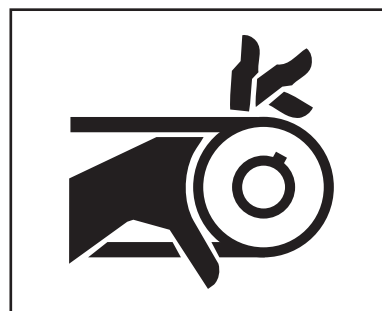

Figure 3.2

WEAR PROPER PROTECTIVE EQUIPMENT

Figure 3.3 - Wear close-fitting clothing and proper safety equipment for the job.

Always wear eye protection when working on or around the machine.

Wear a suitable hearing protection device such as earmuffs or earplugs to protect against high decibels or loud noises.

Prolonged exposure to high decibels or loud noise can cause hearing impairment or loss of hearing.

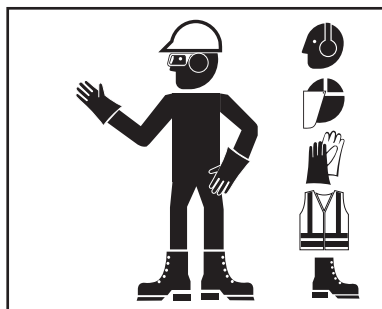

Figure 3.3

Wear protective gloves to protect hands from cuts, abrasions and minor burns.

General Safety Rules

Maintenance

HANDLE FLAMMABLE SOLVENTS SAFELY

Figure 3.4 - Never use diesel fuel, kerosene, gasoline or any flammable solvents for cleaning.

Perform work using flammable fluids and solvents in a safe place away from open flame and sparks. Do not smoke.

Do not weld, grind or flame cut on any tank containing oil, fuel, fumes or any other flammable material, or any container that contents or previous contents are unknown. Move all flammable materials and containers away from work area.

Clean up spilled fuel and oil immediately.

Always have a multipurpose dry chemical fire extinguisher filled and available. Know how to use it.



Figure 3.4

USE PROPER LIFTING EQUIPMENT

Figure 3.5 - Use only lifting devices that meet or exceed OSHA standard 1910.184 or ASME B30.20-2013.

Never lift equipment over people.

Never lift a loaded unit. Never lift unit with any loose objects or persons in the body. Loads may shift or fall if improperly supported, causing death, serious injury or machine damage.

Before unfastening heavy parts or assemblies, support with adequate hoist or other device to prevent falling, tipping, swinging or any other movement that may cause injury or damage.



Figure 3.5

USE PROPER TOOLS FOR THE JOB

Figure 3.6 - Use of improper tools (such as a screwdriver instead of a pry bar, pliers instead of a wrench, a wrench instead of a hammer) can cause serious injuries or machine damage.

Use power tools only to loosen threaded parts and fasteners. Using power tools to tighten may cause over-tightening and component damage.

Use only service parts meeting New Leader specifications.

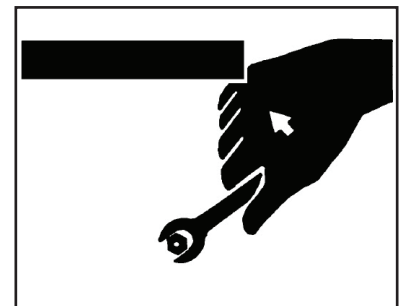

Figure 3.6

General Safety Rules

Maintenance

HIGH PRESSURE FLUID HAZARDS

Figure 3.7 - Escaping fluid under pressure can penetrate the skin causing serious injury.

Always stop machine, allow to cool and relieve pressure before servicing hydraulic system. Never open hydraulic lines under pressure. Make sure all connections are tight and all hoses are in good condition before pressurizing system.

Always use a piece of cardboard or wood to search for leaks instead of hand. Wear impervious gloves and eye protection when servicing system.

Seek medical attention immediately if fluid penetrates your skin. Gangrene may result if wound is left untreated.



Figure 3.7

AVOID HEATING NEAR HIGH PRESSURE FLUID LINES

Figure 3.8 - Flammable spray can be generated by heating near pressurized fluid lines, resulting in burns to yourself and bystanders.

Do not heat by welding, soldering or using a torch near pressurized fluid lines or other flammable materials.

Pressure lines can suddenly burst when heat goes beyond the immediate flame area.

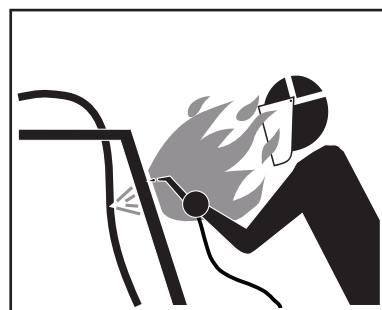

Figure 3.8

AVOID TOXIC FUMES & DUST

Figure 3.9 - Hazardous fumes can be generated when paint is heated from welding, soldering or using a torch.

Remove paint before heating:

- Remove a minimum of 4 in (100mm) from area to be affected by heating. If paint cannot be removed, wear an approved respirator while heating or welding.
- Avoid breathing dust from sanding or grinding on paint.
- If a solvent or paint stripper is used, wash stripper away with soap and water before heating or welding. Remove solvent or paint stripper containers and other flammable material from area. Allow fumes to disperse for at least 15 minutes before heating or welding.

Do not use chlorinated solvents in areas where welding will take place.

Perform all work in a well-ventilated area that will carry all toxic fumes and dust away.



Figure 3.9

CLEAN MACHINE OF HAZARDOUS CHEMICALS



CAUTION

During application of hazardous chemicals, residue can build up on the inside or outside of the vehicle. Clean vehicle according to use instructions of hazardous chemical.

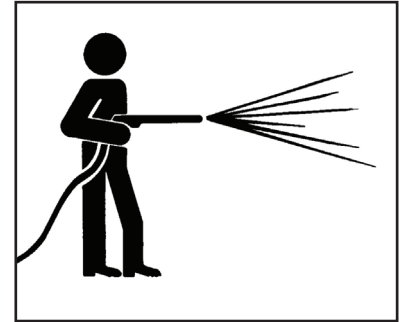

Figure 3.10

Figure 3.10 - When exposed to hazardous chemicals, clean exterior and interior of vehicle daily to keep free of the accumulation of visible dirt and contamination.

1. Clean operator's station to maintain unobstructed visibility of all windows and mirrors, and safe operation of all controls.

NOTICE!

Directing pressurized water at electronic/ electrical components, bearings and hydraulic seals or other sensitive parts and components may cause product malfunctions. Reduce pressure and spray at 45 to 90 degree angles.

2. Wash entire exterior of vehicle.
3. Dispose of any wash water with hazardous concentrations of active or non-active ingredients according to published regulations or directives.

HANDLE BATTERIES SAFELY



WARNING

Sulfuric acid in battery electrolyte is poisonous. It can burn skin, eat holes in clothing, and cause blindness if it contacts eyes.

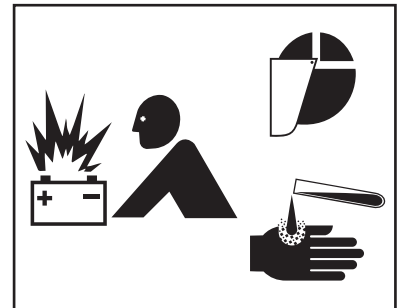

Figure 3.11

Figure 3.11 - Lead acid batteries generate flammable and explosive gases. Keep sparks and flame away from batteries. Do not smoke.

If acid contacts eyes, skin or clothing, flush with water immediately. Seek immediate medical attention if acid contacts eyes.

PROPER TIRE MAINTENANCE

Figure 3.12 - Never weld on a wheel or rim that has a tire on it.

Never attempt to mount or remove a tire unless using the proper equipment, tire safety cage, instructions, training, and you are qualified to perform the work safely. Failure to follow the correct procedures when mounting a tire on a wheel or rim can cause an explosion and serious injury.

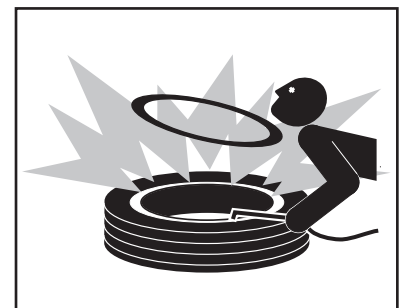

Figure 3.12

Tire service procedures must be performed by trained and qualified personnel.

General Safety Rules

Storage

PARK VEHICLE SAFELY

Figure 4.1 - When leaving the vehicle unattended for any reason, be sure to:

- Shut down PTO.
- Shut off vehicle's engine, and unit's engine if applicable.
- Place vehicle transmission in "Neutral" or "Park".
- Set parking brake firmly.
- Remove ignition key and take it with you.
- Block wheels.

These actions are recommended to avoid unauthorized use, runaway, vandalism, theft and unexpected operation during startup.

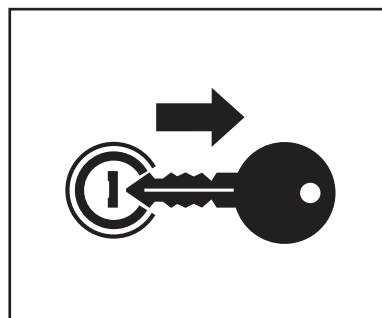

Figure 4.1

SUPPORT MACHINE PROPERLY

Figure 4.2 - When machine is removed from vehicle, always store on adequate supports on a firm level surface. Improper supporting or storage of spreader may cause machine to fall, resulting in serious injury or death.

Never use lifting device to free machine from a chassis, storage stands or frozen ground, or to lift the chassis in any way. Shock loading is prohibited and sudden accelerations must be avoided. Lifting in such a manner could result in injury or machine damage.



Figure 4.2

DISPOSE OF WASTE PROPERLY

Figure 4.3 - Improper disposal of waste can threaten the environment and ecology. Potentially harmful waste used with New Leader equipment such as fuel, oil, filters and batteries.

Use leakproof containers when draining fluids. Do not use food or beverage containers that may mislead someone into drinking from them. Do not pour waste onto the ground, down a drain, or into any water source.

Inquire on proper disposal methods from your local environmental or recycling center, or from your local dealer.

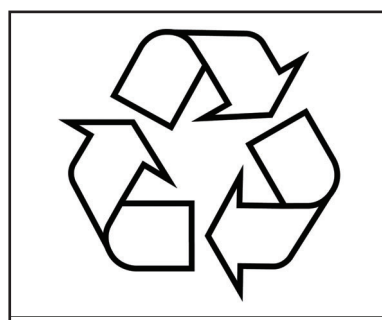

Figure 4.3

SAFETY DECAL MAINTENANCE

Keep safety decals and signs clean and legible at all times.

Replace safety decals and signs that are missing or have become illegible.

Replaced parts that displayed a safety sign should also display the current sign.

Safety decals or signs are available from your dealer's Parts Department or from Highway Equipment Company by calling (800) 363-1771.

SAFETY DECAL INSTALLATION

CLEAN SURFACE

Wash the installation surface with a synthetic, free-rinsing detergent. Avoid washing the surface with a soap containing creams or lotion. Allow to dry.

POSITION SAFETY DECAL

Decide on the exact position before application. Application marks may be made on the top or side edge of the substrate with a lead pencil, marking pen, or small pieces of masking tape. NOTE: Do not use chalk line, china marker, or grease pencil. Safety decals will not adhere to these.

Remove the Liner

A small bend at the corner or edge will cause the liner to separate from the decal. Pull the liner away in a continuous motion at a 180-degree angle. If the liner is scored, bend at score and remove.

APPLY SAFETY DECAL

Tack decal in place with thumb pressure in upper corners. Using firm initial squeegee pressure, begin at the center of the decal and work outward in all directions with overlapping strokes. NOTE: Keep squeegee blade even—nicked edges will leave application bubbles. Pull up tack points before squeegeeing over them to avoid wrinkles.

REMOVE PRE-MASK

If safety decal has a pre-mask cover remove it at this time by pulling it away from the decal at a 180 degree angle. NOTE: It is important that the pre-mask covering is removed before the decal is exposed to sunlight to avoid the pre-mask from permanently adhering to the decal.

REMOVE AIR POCKETS

Inspect the decal in the flat areas for bubbles. To eliminate the bubbles, puncture the decal at one end of the bubble with a pin (never a razor blade) and press out entrapped air with thumb moving toward the puncture.

RE-SQUEEGEE ALL EDGES

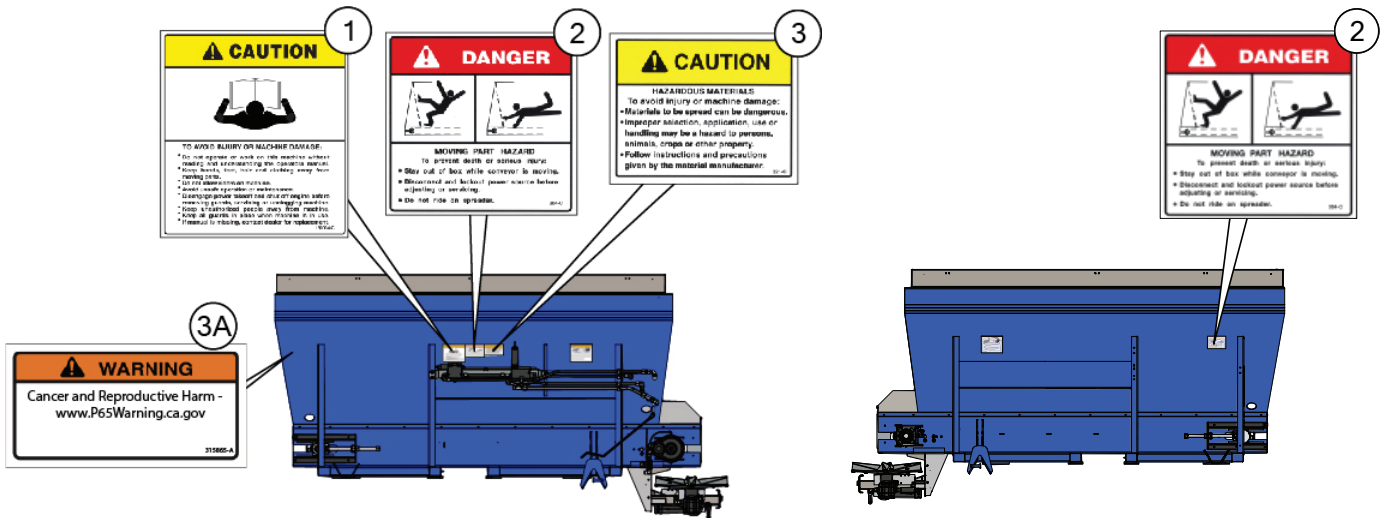

1. CAUTION: TO AVOID INJURY OR MACHINE DAMAGE:

- Do not operate or work on this machine without reading and understanding the operator's manual.
- Keep hands, feet, hair and clothing away from moving parts.
- Do not allow riders on machine.
- Avoid unsafe operation or maintenance.
- Disengage power takeoff and shut off engine before removing guards, servicing or unclogging machine.
- Keep unauthorized people away from machine.
- Keep all guards in place when machine is in use.
- If operator's manual is missing, contact your local New Leader dealer or print a new copy from www.highwayequipment.com.

150034-C

2. DANGER: MOVING PART HAZARD

To prevent death or serious injury:

- Stay out of box while conveyor is moving.
- Disconnect and lock out power source before adjusting or servicing.
- Do not ride on the spreader.

364-C

3. CAUTION: HAZARDOUS MATERIALS

To avoid injury or machine damage:

- Materials to be spread can be dangerous.
- Improper selection, application, use or handling may be hazardous to persons, animals, crops or other property.
- Follow instructions and precautions given by material manufacturer.

321-C

3A. To avoid injury or machine damage:

- Cancer and Reproductive Harm - www.P65Warning.ca.gov

315865-A

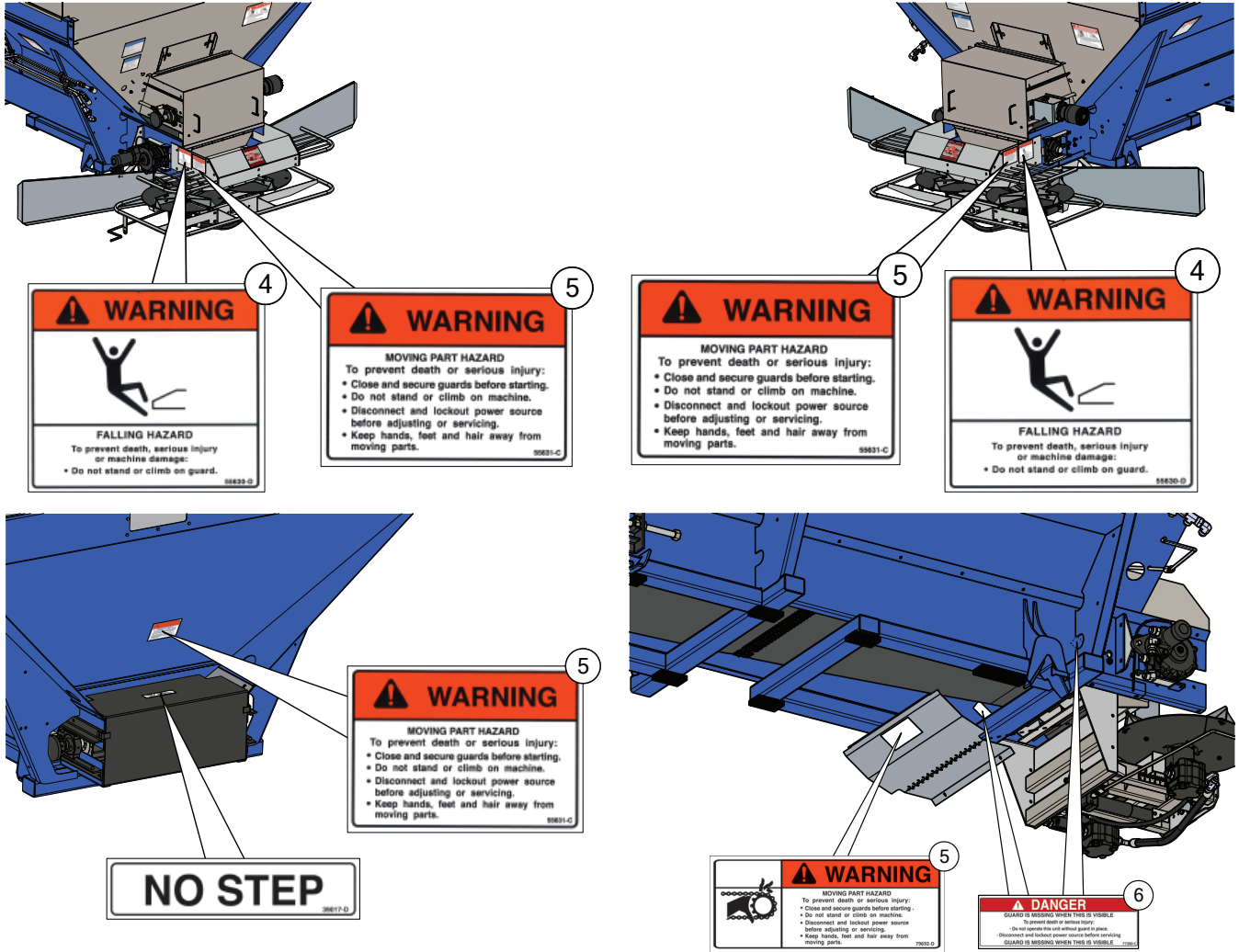

4. WARNING: FALLING HAZARD
To prevent death, serious injury or machine damage:

- Do not climb or stand on guard.

55631-D
39017-D

5. WARNING: MOVING PART HAZARD
To prevent death or serious injury:

- Close and secure guards before operating machine.
- Do not stand or climb on machine.
- Disconnect and lockout power source before adjusting or servicing.
- Keep hands, feet and hair away from moving parts.

55631-C
79692-D

6. DANGER: GUARD IS MISSING WHEN THIS IS VISIBLE
To prevent death or serious injury:

- Do not operate this unit without guard in place.
- Disconnect and lockout power source before servicing.

77380-C
308191-A

Safety Decals

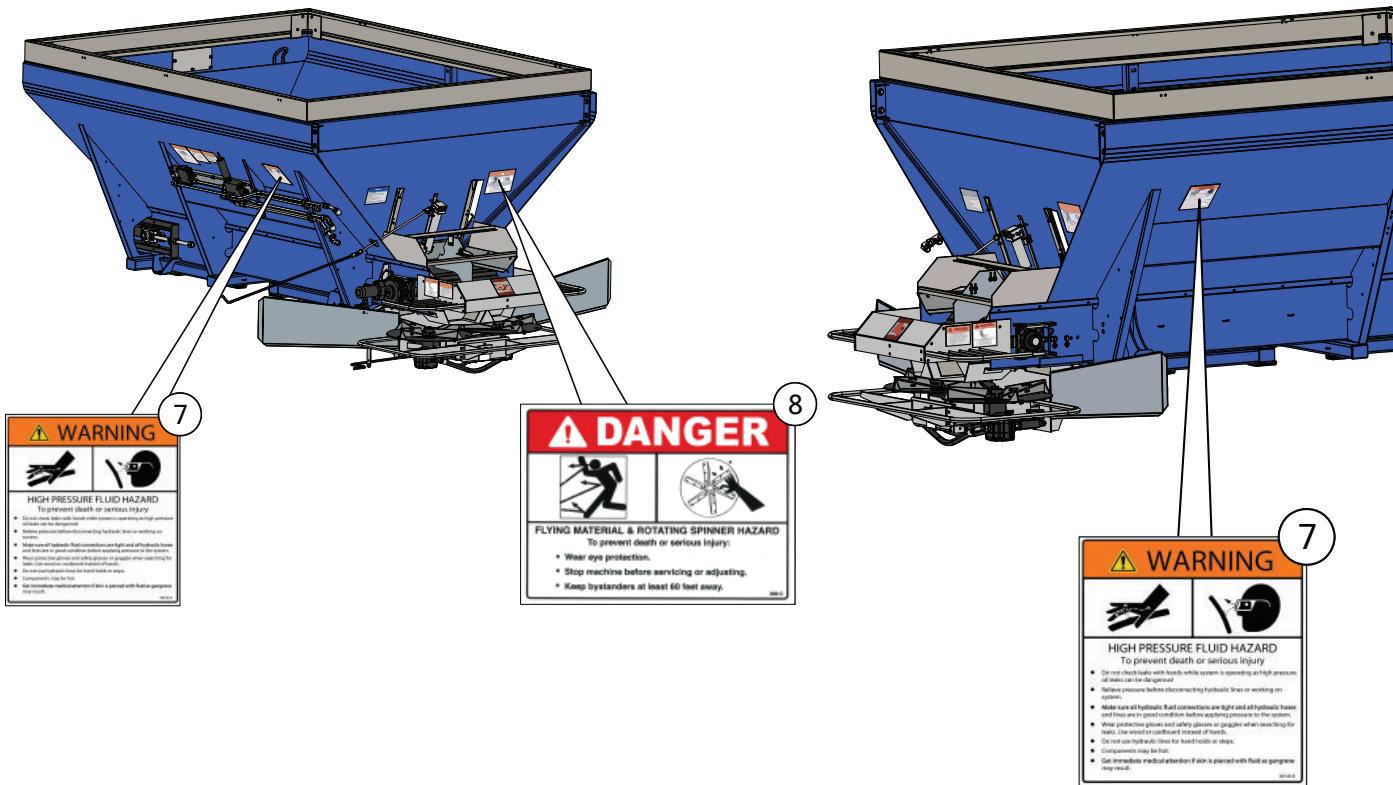

7. WARNING: HIGH-PRESSURE FLUIDS

To prevent death or serious injury:

- Do not check for leaks with hands while system is operating as high pressure oil leaks can be dangerous!
- Relieve system pressure before disconnecting hydraulic lines or working on system.
- Make sure all hydraulic fluid connections are tight and all hydraulic hoses and lines are in good condition before applying pressure to the system.
- Wear protective gloves and safety glasses or goggles when searching for leaks. Use wood or cardboard instead of hands.
- Do not use hydraulic lines for hand holds or steps.
- Components may be hot.
- Get immediate medical attention if skin is pierced with fluid as gangrene may result.

39138-D

8. DANGER: FLYING MATERIAL AND ROTATING SPINNER HAZARD

To prevent death or serious injury:

- Wear eye protection.
- Stop machine before servicing or adjusting.
- Keep bystanders at least 60 feet away.

368-C

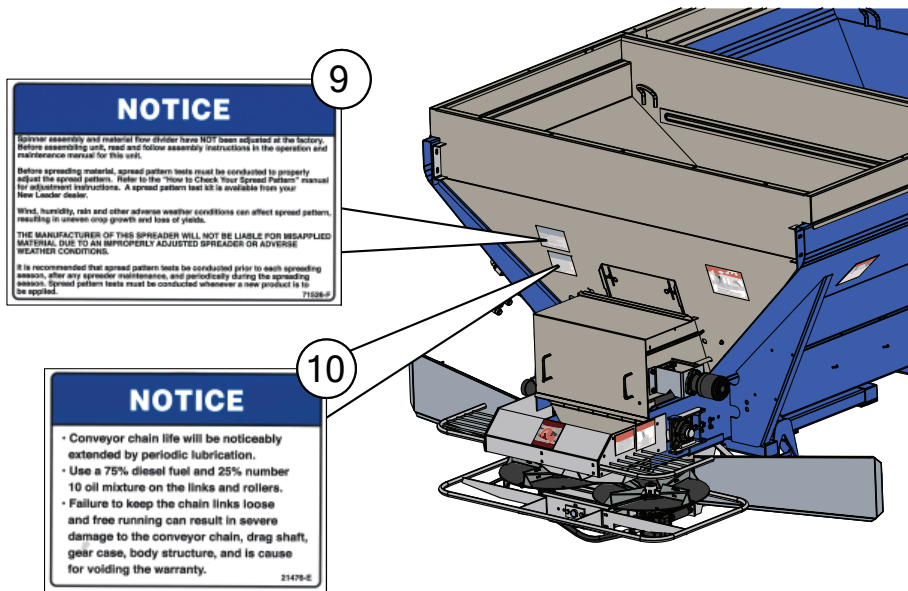

9

NOTICE

Spinner assembly and material flow divider have NOT been adjusted at the factory. Before assembling unit, read and follow assembly instructions in the operation and maintenance manual for this unit.

Before spreading material, spread pattern tests must be conducted to properly adjust the spread pattern. Refer to the "How to Check your Spread Pattern" manual for adjustment instructions. A spread pattern test kit is available from your New Leader dealer.

Wind, humidity, rain and other adverse weather conditions can affect spread pattern, resulting in uneven crop growth and loss of yields.

THE MANUFACTURER OF THIS SPREADER WILL NOT BE LIABLE FOR MISAPPLIED MATERIAL DUE TO AN IMPROPERLY ADJUSTED SPREADER OR ADVERSE WEATHER CONDITIONS.

It is recommended that spread pattern tests be conducted prior to each spreading season, after any spreader maintenance, and periodically during the spreading season. Spread pattern tests must be conducted whenever a new product is to be applied.

71526-F

10

NOTICE

- Conveyor chain life will be noticeably extended by periodic lubrication.
- Use a 75% diesel fuel and 25% number 10 oil mixture on the links and rollers.
- Failure to keep the chain links loose and free running can result in severe damage to the conveyor chain, drag shaft, gear case, body structure, and is cause for voiding the warranty.

21476-E

9. NOTICE: SPREAD PATTERN TESTING

To obtain optimal machine performance:

Spinner assembly and material flow divider have NOT been adjusted at the factory. Before assembling unit, read and follow assembly instructions in the operation and maintenance manual for this unit.

Before spreading material, spread pattern tests must be conducted to properly adjust the spread pattern. Refer to the "How to Check your Spread Pattern" manual for adjustment instructions. A spread pattern test kit is available from your New Leader dealer.

Wind, humidity, rain and other adverse weather conditions can affect spread pattern, resulting in uneven crop growth and loss of yields.

THE MANUFACTURER OF THIS SPREADER WILL NOT BE LIABLE FOR MISAPPLIED MATERIAL DUE TO AN IMPROPERLY ADJUSTED SPREADER OR ADVERSE WEATHER CONDITIONS.

It is recommended that spread pattern tests be conducted prior to each spreading season, after any spreader maintenance, and periodically during the spreading season. Spread pattern tests must be conducted whenever a new product is to be applied.

71526-F

10. NOTICE: CONVEYOR CHAIN LUBRICATION

To avoid machine damage and premature wear:

- Conveyor chain life will be noticeably extended by periodic lubrication.
- See "Lubricant & Hydraulic Oil Specifications" in this manual for details.
- Failure to keep the chain links loose and free running can result in severe damage to the conveyor chain, drag shaft, gearcase and body structure, and is cause for voiding the warranty.

21476-E

This page is intentionally left blank.

Recommended sequence of installation is:

1. Mounting of spreader.
2. Installation of chassis hydraulic hose and electrical wiring to spreader.
3. Installation of optional parts.
4. Filling of hydraulic reservoir and lubrication.
5. Checking for leaks and proper functioning.

HYDRAULIC REQUIREMENTS

Model		GPM (LPM) (Gallons/Liters per Minute)	Maximum Pressure (PSI)
L3030G4	Spinner & Conveyor	30 (114)	3100
	MULTIPLIER	9 (34)	2000

LIFTING THE SPREADER



WARNING

Use only lifting devices that meet or exceed OSHA standard 1910.184 or ASME B30.20-2006. Never lift equipment over people. Never lift unit with anything or anybody in the body. Loads may shift or fall if improperly supported, causing damage to unit, injury or even death.



CAUTION

Do not use lifting device to free unit from a chassis, storage stands or frozen ground, or to lift the chassis in any way. Shock loading is prohibited and sudden accelerations should be avoided. Lifting in such a manner could result in damage to unit or injury.

Always inspect unit lift points for signs of wear, cracking, corrosion, gouges, alterations, or distortion.

Always use a sling, spreader bar, or lifting bar that attaches to the lifting points with a minimum of 60 degrees from horizontal. It is preferable to use an "H" style lifting bar that keeps the attaching chains in a near vertical orientation as shown in Figure 1. Operators of lifting devices must be qualified and knowledgeable in their use and application.

Position the chassis with adequate room around the unit. Work in an environment that permits clear communication to others nearby. Keep area clear of persons when loads are to be lifted and suspended. Do not allow the lifted load to come in contact with any obstruction.

Store units on a solid surface using appropriate storage stands when not installed.

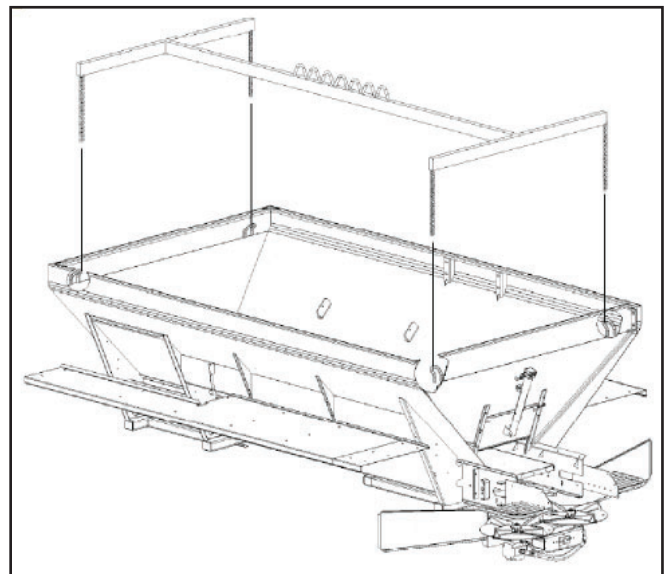

Figure 1 - Lifting Bar

INSTALLING BODY

NOTICE! DO NOT WELD ON VEHICLE FRAME! Such welding can lead to fatigue cracking and must be avoided.

NOTICE! Connect welders ground directly to one of the items being welded anytime an arc welder is used on the vehicle or anything connected to the vehicle. Refer to Manufacturer's instructions.

IMPORTANT! Disconnect electrical components from electrical system when welding on equipment to prevent component damage due to power surges or excessive current.

Mounts

Position unit over chassis and align mounts. Carefully lower unit onto chassis.

Install mounting hardware and tighten to specified torque. Refer to "Standard Torques" in the Maintenance section of this manual.

ELECTRICAL CONNECTIONS

Connect all electrical control circuits. All wiring should be approved automotive insulated wire, supported adequately with insulating ties or straps, and located where it will not interfere with any control or access. Make sure wiring does not contact any moving parts or sharp edge and is kept away from any hydraulic lines or any heated part.

HYDRAULIC HOSE INSTALLATION

**CAUTION**

If a threaded connection is tightened too tightly, the fitting or housing into which the fitting is placed could be distorted and an unstoppable leak could occur.

**WARNING**

Do not use one manufacturer's hose with another manufacturer's fittings! Such will void any warranty and may cause premature burst or leak of hydraulic fluids! Severe injury and/or fire could result!

Locate pressure port on chassis. Install spreader pressure hose to this connection. Connect suction hose to opposite connection. Connect additional hoses as necessary. Use plastic tie straps as necessary to support hoses so they will not catch on field obstructions or contact hot or moving parts.

HYDRAULIC HOSE INSTALLATION GUIDE

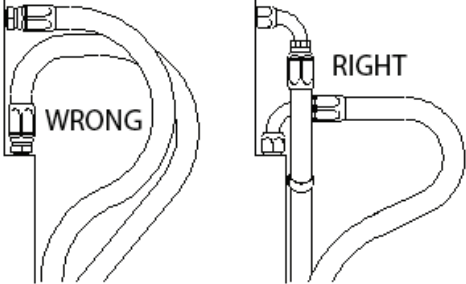
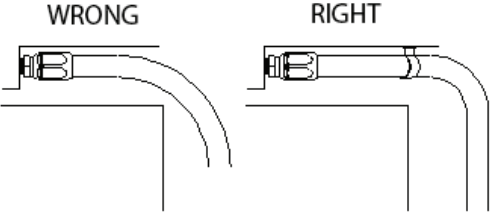
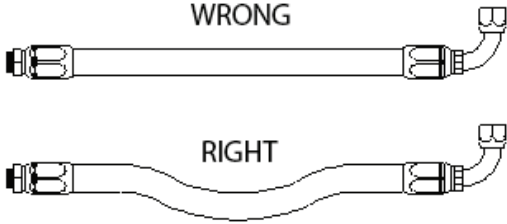
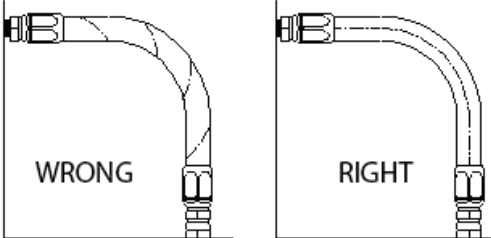
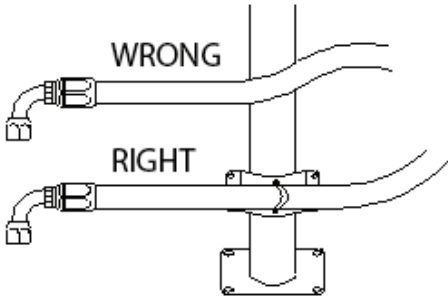
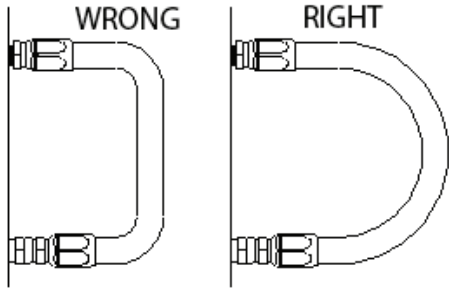
	
<p>1. Use elbows and adapters in the installation to relieve strain on the assembly, and to provide easier and neater installations that are accessible for inspection and maintenance. Remember that metal end fittings cannot be considered as part of the flexible portion of the assembly.</p>	<p>2. Install hose runs to avoid rubbing or abrasion. Clamps are often needed to support long runs of hose or to keep hose away from moving parts. It is important that the clamps be of the correct size. A clamp that is too large will allow the hose to move in the clamp causing abrasion at this point.</p>
	
<p>3. In straight hose installations allow enough slack in the hose line to provide for changes in length that will occur when pressure is applied. This change in length can be from +2% to -4%.</p>	<p>4. Do not twist hose during installation. This can be determined by the printed layline on the hose. Pressure applied to a twisted hose can cause hose failure or loosening of the connections.</p>
	
<p>5. Keep hose away from hot parts. High ambient temperature will shorten hose life. If you cannot route it away from the heat source, insulate it.</p>	<p>6. Keep the bend radii of the hose as large as possible to avoid hose collapsing and restriction of flow. Follow catalog specs on minimum bend radii.</p>

(Used with the permission of The Weatherhead Company.)

Recommended sequence of installation is:

1. Spreader preparation.
2. Insert preparation.
3. Mounting of insert.
4. Connecting hydraulic hoses.
5. Installation of hillside divider and conveyor cover.
6. Checking installation.
7. Checking for leaks and proper functioning.

SPREADER PREPARATION



WARNING

Use only lifting devices that meet or exceed OSHA standard 1910.184. Never exceed work load limits or lift equipment over people. Empty spreader before lifting. Loads may shift or fall if improperly supported, causing injury.

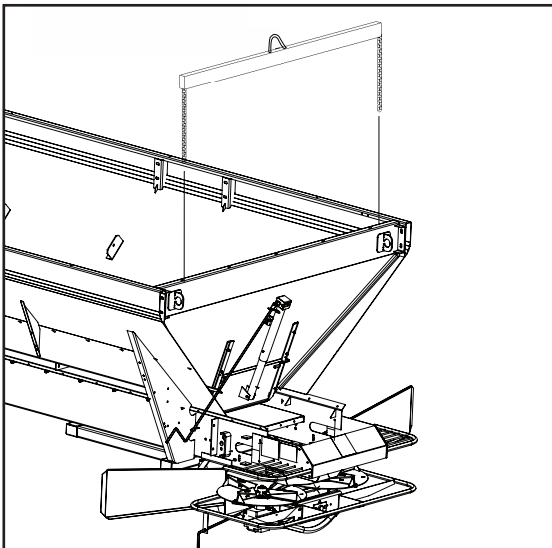

Figure 1

Remove the Inverted "V" and Hillside Divider from the spreader, if so equipped, and set hardware aside.

Remove Feedgate Jack Handle and set aside. Support endgate by attaching a hoist to the lift hooks. Remove hardware from both sides of the endgate and carefully remove from the spreader as shown in Figure 1.

NOTE: Always use a sling, spreader bar, or lifting bar that attaches to the lifting points with a minimum of 60 degrees from horizontal. It is preferable to use a straight style lifting bar that keeps the attaching chains in a near vertical orientation.

NOTE: Always inspect unit lift hooks for signs of wear, cracking, corrosion, gouges, alterations, or distortion before use.

Style I

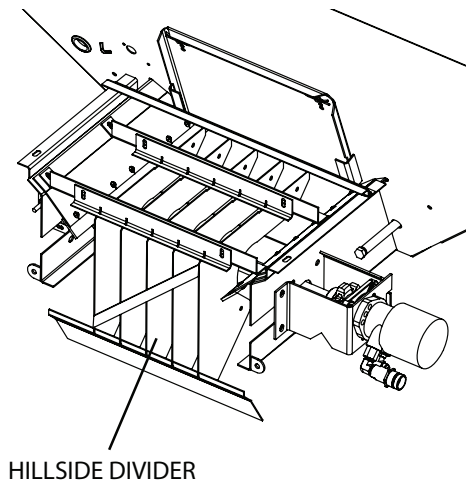
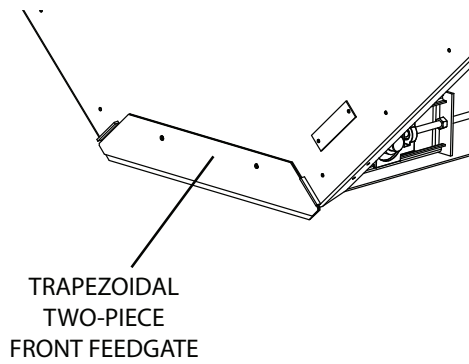
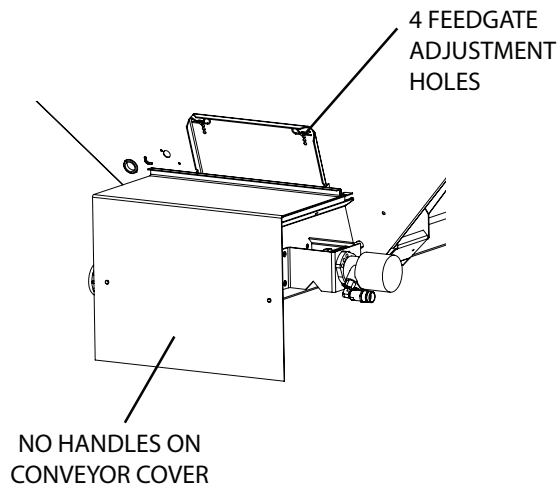

Style II

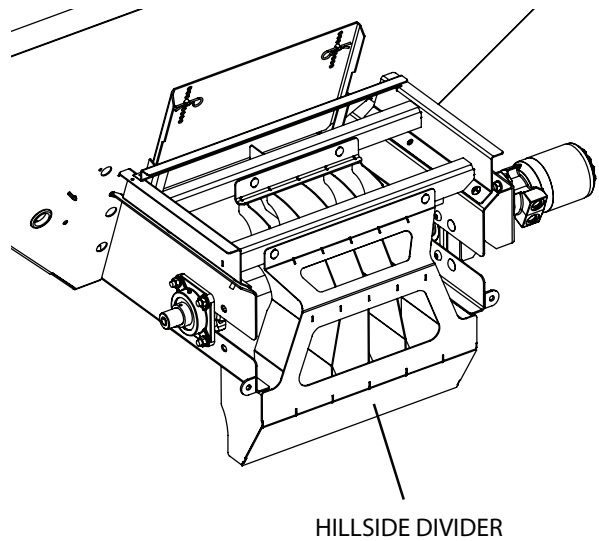
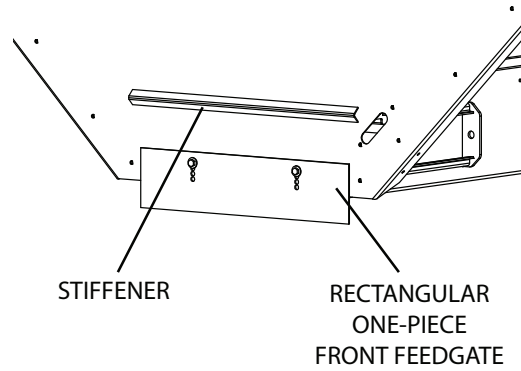
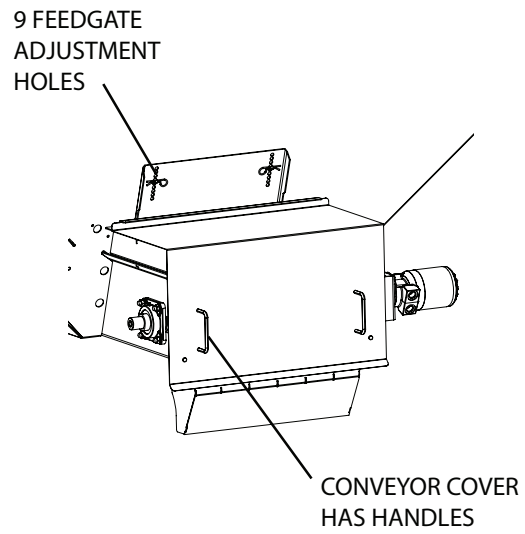

FEEDGATE ADJUSTMENT



WARNING

Stay out of the spreader. If it's necessary to enter the spreader, return to the shop, empty body, turn off all power, set vehicle brakes, lock engine starting switch and remove keys before entering. Tag all controls to prohibit operation. Tags should be placed, and later removed, only by person working in the body.

Adjust the insert's front feedgate prior to installation.

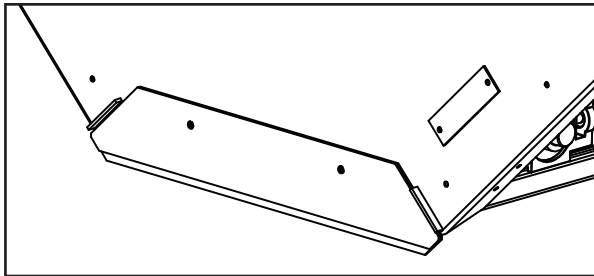

Figure 2A - 1 1/2" (3.81 cm) or 2" (5.08 cm) Opening
(Style I MultApplier)

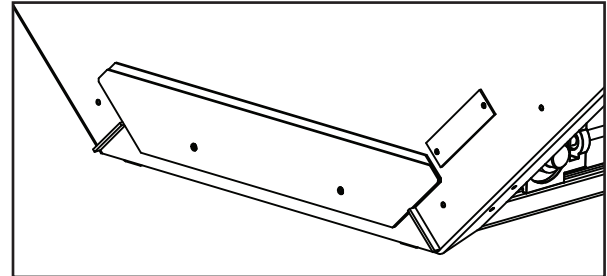

Figure 2B - 3" (7.62 cm) Opening
(Style I MultApplier)

Style I MultApplier - To adjust main bin's feedgate opening on a Style I MULTAPPLIER-equipped unit: position front feedgates on MULTAPPLIER as necessary to achieve a 1-1/2 inch (3.81 cm), 2 inch (5.08 cm) (Figure 2A) or 3 inch (7.62 cm) (Figure 2B) opening. Position both feedgates with short side down for a 3" (7.62 cm) opening. NOTE: Both feedgates are installed for shipping.

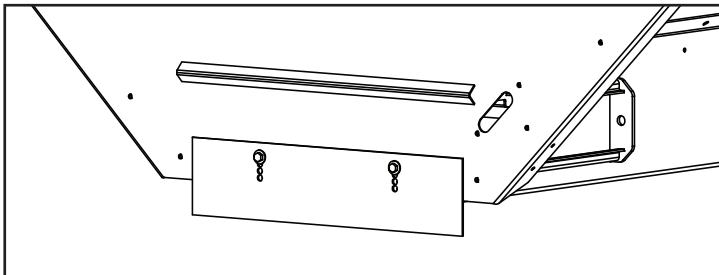

Figure 3A - 2 1/2" (3.81 cm) or 2" (5.08 cm) Opening
(Style II MultApplier)

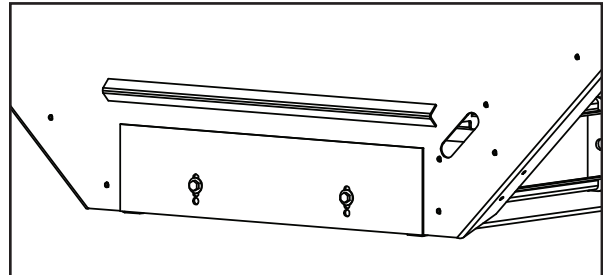

Figure 3B - 4" (10.16 cm) Opening
(Style II MultApplier)

Style II MULTAPPLIER - To adjust main bin's feedgate opening on a Style II MULTAPPLIER-equipped unit: position front feedgate on MULTAPPLIER as necessary to achieve a 1 1/2 inch (3.81 cm) (Figure 3A) to 4 inch (10.16 cm) (Figure 3B) opening in 1/2 inch increments.

INSERT INSTALLATION



WARNING

Use only lifting devices that meet or exceed OSHA standard 1910.184. Never exceed work load limits or lift equipment over people. Empty spreader before lifting. Loads may shift or fall if improperly supported, causing injury.

Before installing the insert:

Parts Needed:

<u>Description</u>	<u>Qty</u>
Insert Unit	1
Capscrew - 1/2 x 1 1/4 Grade 8	8
Flat Washer - 1/2 Grade 8	16
Lock Washer - 1/2 Grade 8	8
Hex Nut - 1/2 Grade 8	8

Make sure rubber sealer hardware is loose. If not, loosen.

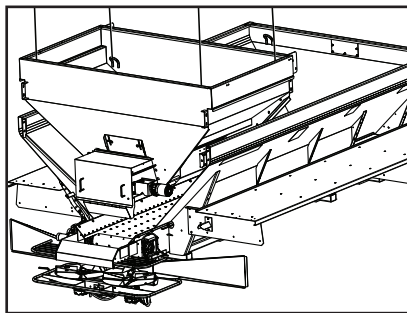

Figure 4A

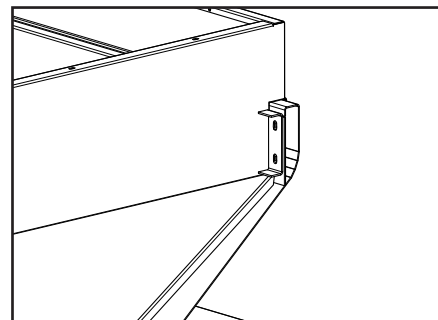

Figure 4B

To install insert bin:

Figure 4A - Hoist and slide insert into position between main bin's side sheets.

Figure 4B - Align front and rear mount brackets.

Make sure insert is resting on inside of main bin, and not resting on tops of side sheets.

Release tension on hoist but do not remove.

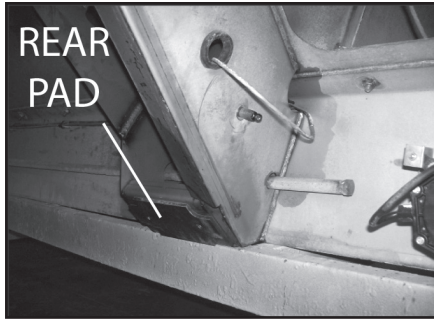

Figure 5A (uninstalled)

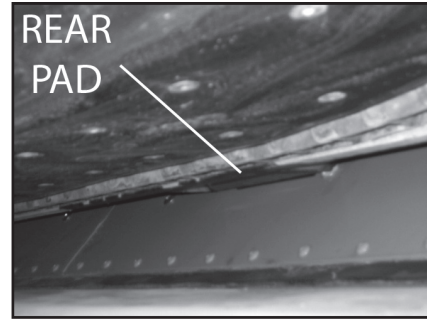

Figure 5B (shown installed)
View from rear of unit.

Figures 5A-5B - Visually make sure insert is centered from side to side in main bin and rear pads are resting on main bin.

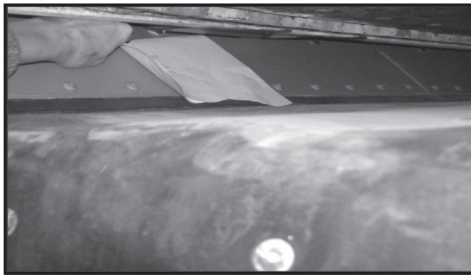

Figure 6



Figure 7

Figure 6 - There must be contact between rear pads and main unit. Check for contact by trying to slide paper between pads and main bin. If no contact, adjust insert.

Figure 7 - Inside main unit, locate front pads by lifting rubber sealers on front endgate.

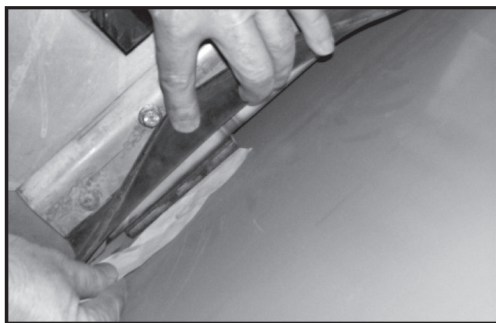

Figure 8A



Figure 8B

Figures 8A-8B - There must be contact between front pads and main bin. Check for contact by trying to slide paper between pads and main bin. If no contact, adjust insert.

NOTE: Pry insert at mount brackets if necessary.



Figure 9



Figure 10



Figure 11

Figure 9 - Once both front pads make contact, insert hardware in front mount brackets' lower holes. Shim between main bin and insert brackets if distance is larger than 1/8" (.32cm). Tighten hardware per torque recommendations in this manual.

Figure 10 - Make sure front feedgate is level. Lower endgate sealers so flush with chain shields and tighten hardware.

NOTICE! Leakage of material may occur if the sealer belts are not set properly on the front of the insert. Highway Equipment Company is not liable for lost material due to improperly installed sealer belts.

Figure 11 - Make sure there is a complete seal covering the gap between the insert and the main bin's side sheets. Tighten all hardware on rubber sealers at front of insert.

Make sure rear pads are still in place against main bin. Install hardware in lower holes of rear mount brackets. Shim between main bin and insert brackets if distance is larger than 1/8" (.32cm). Tighten hardware per torque recommendations in this manual.

Make sure insert's side sheets are not resting on top of main bin's side sheets.

Install hardware in all four mount brackets' upper holes. Tighten hardware per torque recommendations.

Remove hoist.

Inspect unit for foreign debris in conveyor area.

HYDRAULICS

Attach insert hoses to spreader hoses as shown in Figure 17.

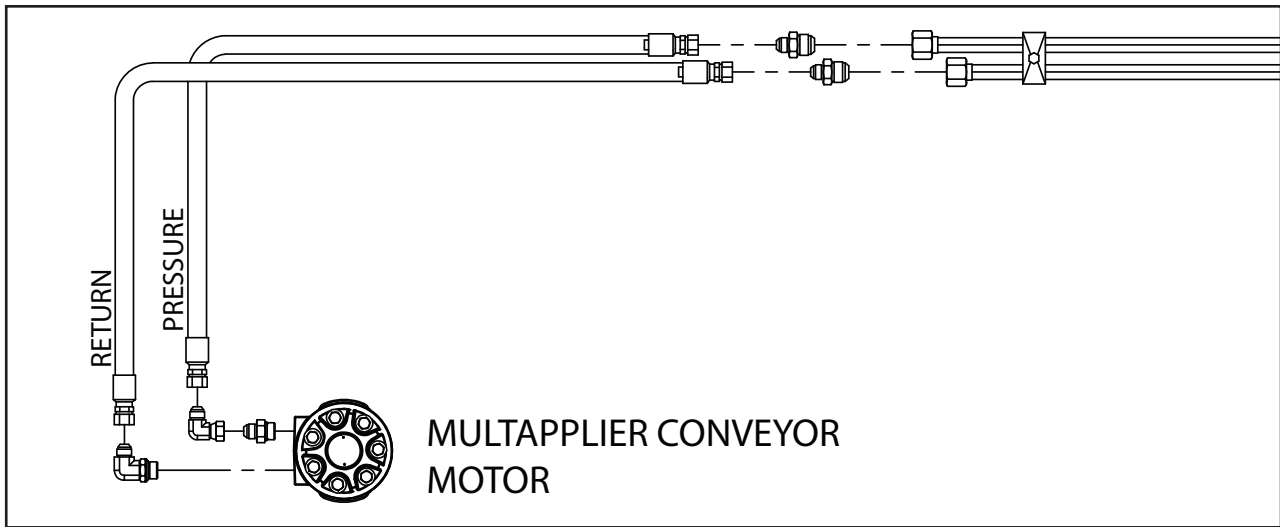

Figure 17 - MULTAPPLIER Operation

HYDRAULIC INSTALLATION

Refer to "Installation Guide" for proper hydraulic hose installation guidelines.

If insert was purchased separately from spreader, refer to parts pages for hydraulic installation.

HILLSIDE DIVIDER & CONVEYOR COVER

NOTICE!

Highway Equipment Company will not be liable for misapplied material due to an improperly adjusted divider, spreader or both.

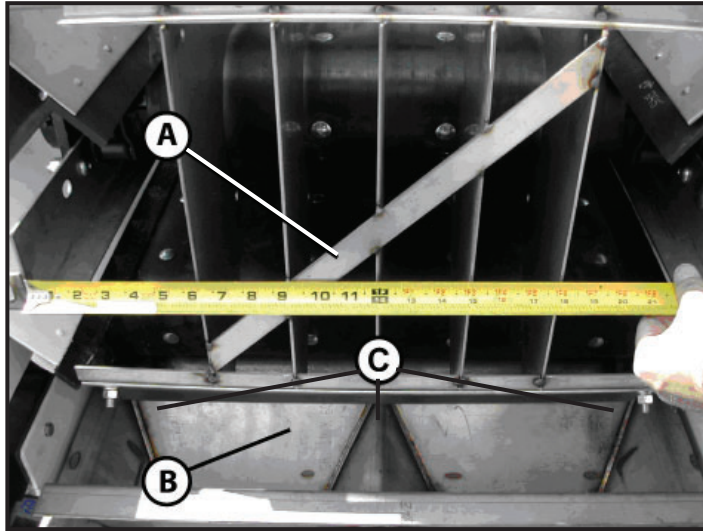

Figure 19A - MULTAPPLIER Hillside Divider (Style I)

Style I MULTAPPLIER - Remove hardware from rear two chain shield holes on each side of MULTAPPLIER and set aside. Install MULTAPPLIER Hillside Divider (A) over conveyors and attach using chain shield hardware. Adjust Hillside Divider so that the middle divider is centered over both conveyors and the Material Divider (B) as shown in Figure 19A.

Measure from drop-off point of Hillside Divider to Material Divider Back Plate at center and at both edges. Ensure all three distances are equal. Tighten hardware to recommended torque.

Measure Hillside Divider Kick Plate (C) from drop point of kicker plate to conveyor belt. Measurement from left side to center and center to right side should be equal.

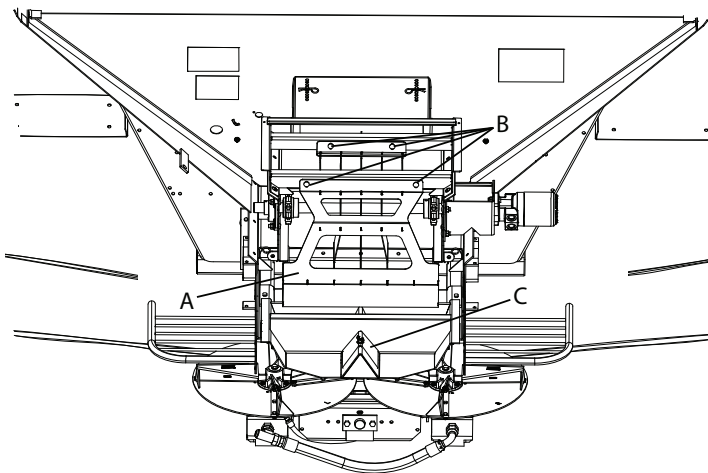

Figure 19B - MULTAPPLIER Hillside Divider (Style II)

Style II MULTAPPLIER - Loosen hardware from rear two chain shield holes on each side of MULTAPPLIER. Install MULTAPPLIER Hillside Divider (A) and fasten to Support using single bin Hillside Divider hardware removed before MULTAPPLIER installation (B). Adjust Hillside Divider so that the middle divider is centered over both conveyors and the Material Divider (C) as shown in Figure 19B. Tighten all hardware to recommended torque.

ELECTRICAL CONNECTIONS

Connect all electrical control circuits. All wiring should be approved automotive insulated wire, supported adequately with insulating ties or straps, and located where it will not interfere with any control or access. Make sure wiring does not contact any moving parts or sharp edges and is kept away from hydraulic lines and heated parts.

Plug in Encoder.

INSERT REMOVAL/ENDGATE INSTALLATION

Remove insert and reinstall endgate, Inverted "V", single conveyor Hillside Divider, etc. by following applicable installation instructions in reverse order. Make sure the insert hydraulics, electrical connections and air lines are disconnected from the spreader before removal. See "Inverted V" in spreader parts manual.

Hydraulics Removal

Route hydraulic hoses on the spreader and the insert as shown in Figure 20.

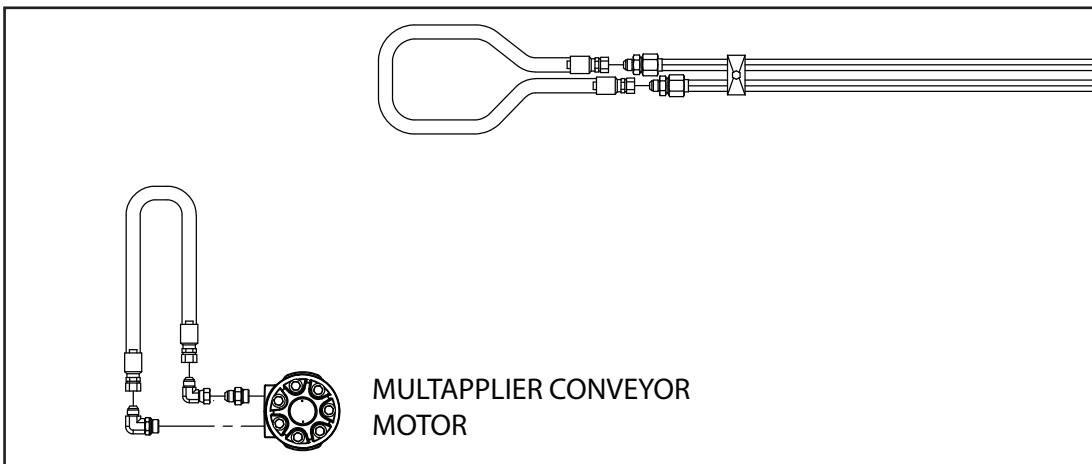

Figure 20 - Detach MULTAPPLIER

The CNH L3030G4 is a hopper type spreader intended for spreading free flowing granular agricultural materials, such as chemical fertilizers. The is intended for mounting on the Miller Condor and New Holland Guardian - high-clearance post-emergence application vehicles.

The unit is powered hydraulically and provides independent variable speed control for the spinners and full automatic ground speed control for the conveyor. The hydraulic pump, which provides the hydraulic power, is a variable displacement type pump and is driven by means of a mechanical gear drive from the engine.

The conveyor delivers material to the spinners through an adjustable metering gate at the rear of the hopper body. An orbital type hydraulic motor mounted to a 6-to-1 ratio spur gear case drives the conveyor. The conveyor is a #5 straight-belt conveyor, consisting of a moderately oil resistant (MOR) conveyor belt joined with a mechanical splice. The conveyor belt rides on turnkleen-style drive, idler and snubber pulleys.

The spinner assembly has two 24-inch (61cm) diameter dished discs. Each disc has four formed and heat treated fins that are adjustable to radial angle. The spinner is fully longitudinally adjustable by means of a rotating handle.

The optional 304 stainless steel hopper style spreader MULTAPPLIER may be inserted in the main bin.

- Inserting the MULTAPPLIER allows for two materials to be spread simultaneously. It features a 24-inch (61 cm) belt-over-chain type conveyor consisting of parallel strands of pintle type chain joined by cross bars every other link. The direct-driven conveyor is also controlled independently, enabling the delivery of material at variable rates through the adjustable gate at the rear of the hopper body. The hillside divider improves material placement on the spinner for a more effective spread pattern.
- The MULTAPPLIER is currently available in two styles; Style I and Style II. The Style II MULTAPPLIER offers increased output capabilities. Refer to "MULTAPPLIER Style Comparison" to determine your style of MULTAPPLIER.

This product is intended for commercial use only.

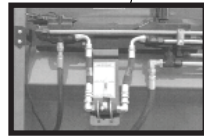
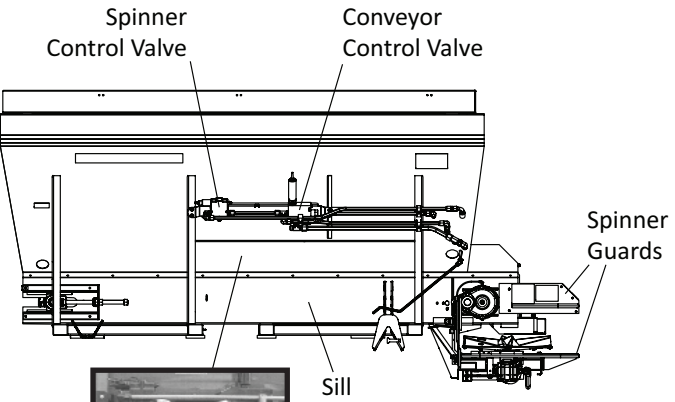
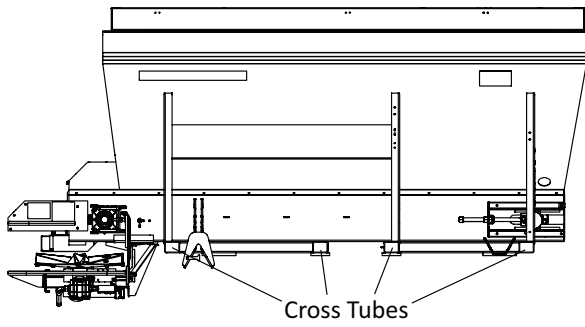
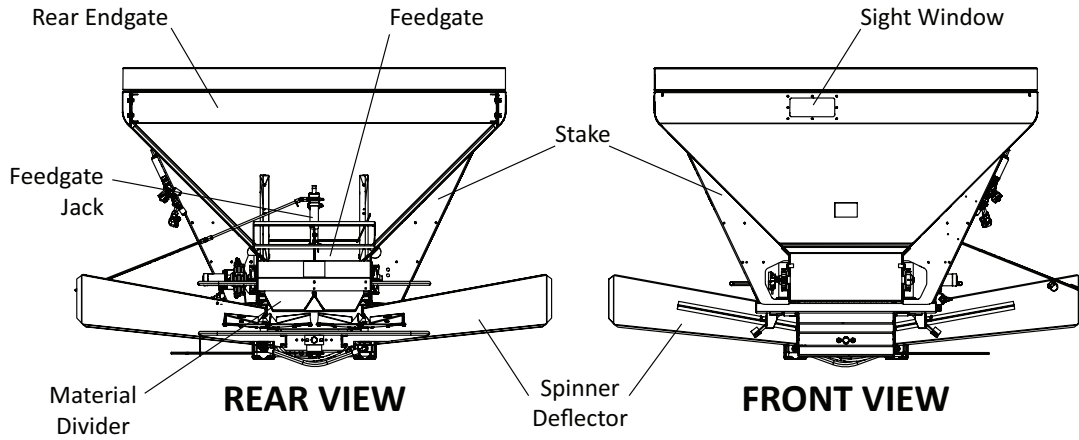

Unload Operation Valve

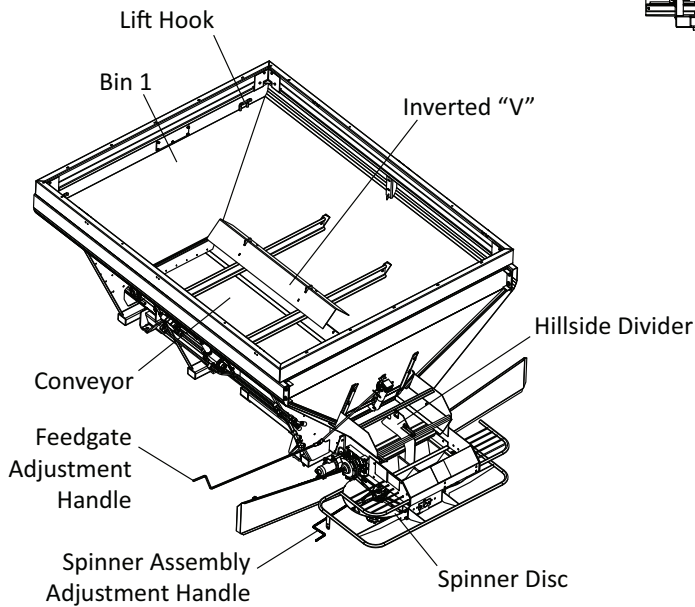

Bin 1: Main holding bin for material or Insert. Insert bins (shown on following pages as applicable) are configured as Bins 1 and 2 depending on type used. Availability varies per model of spreader.

Conveyor: Conveys material to rear of unit.

Conveyor Control Valve: Hydraulic valve with electronic motorized control, regulates flow to conveyor motor. Additional control valve added for insert bin.

Cross Tubes: Support body, attach to Chassis frame. Transfer weight from Main Hopper to Chassis.

Feedgate: Adjustable gate mounted into Rear Endgate. Allows for variable rates of material flow by adjusting jack to desired height.

Hillside Divider: Ensures balanced flow of material across conveyor when on hillsides or uneven terrain.

Inverted "V": Mounted inside Main Hopper when Insert not installed. Distributes weight pressure across conveyor, allowing for consistent material flow to Feedgate, and promotes an improved blend when spreading fertilizer.

Lift Hooks: Used to lift unit or insert with appropriately rated lifting device.

Material Divider: Ensures uniform spread pattern by directing material off of conveyor onto spinner discs.

Rear Endgate: Bolt-in endgate furthest from chassis cab (Rear based on direction of travel). Holds mounted Feedgate, allowing for rear release of material from bin.

Sight Window: Allows viewing of inside of Bin 1 from vehicle cab.

Sill: Base of Main Hopper side walls. Contains Conveyor and supports machine walls.

Spinner Assembly: Contains adjustable G4 Spreader system, consisting of hydraulic spinners used for dispersal of various materials at different positioned settings allowing for consistent, even spread patterns across a wide variety of material with a high rate of accuracy.

Spinner Control Valve: Hydraulic valve with PWM control, regulates flow to spinner motors.

Spinner Deflectors: Deflect material away from machine.

Spinner Guards: Upper and Lower guards, protects operators from spinner discs. Must be in place during any operation.

Stake: Side support for main hopper walls.

Unload Operation Valve: Closed center ball valve equipped on MultiApplier complete units. Valve is open for normal operation, must be closed to perform calibration process.

MULTAPPLIER

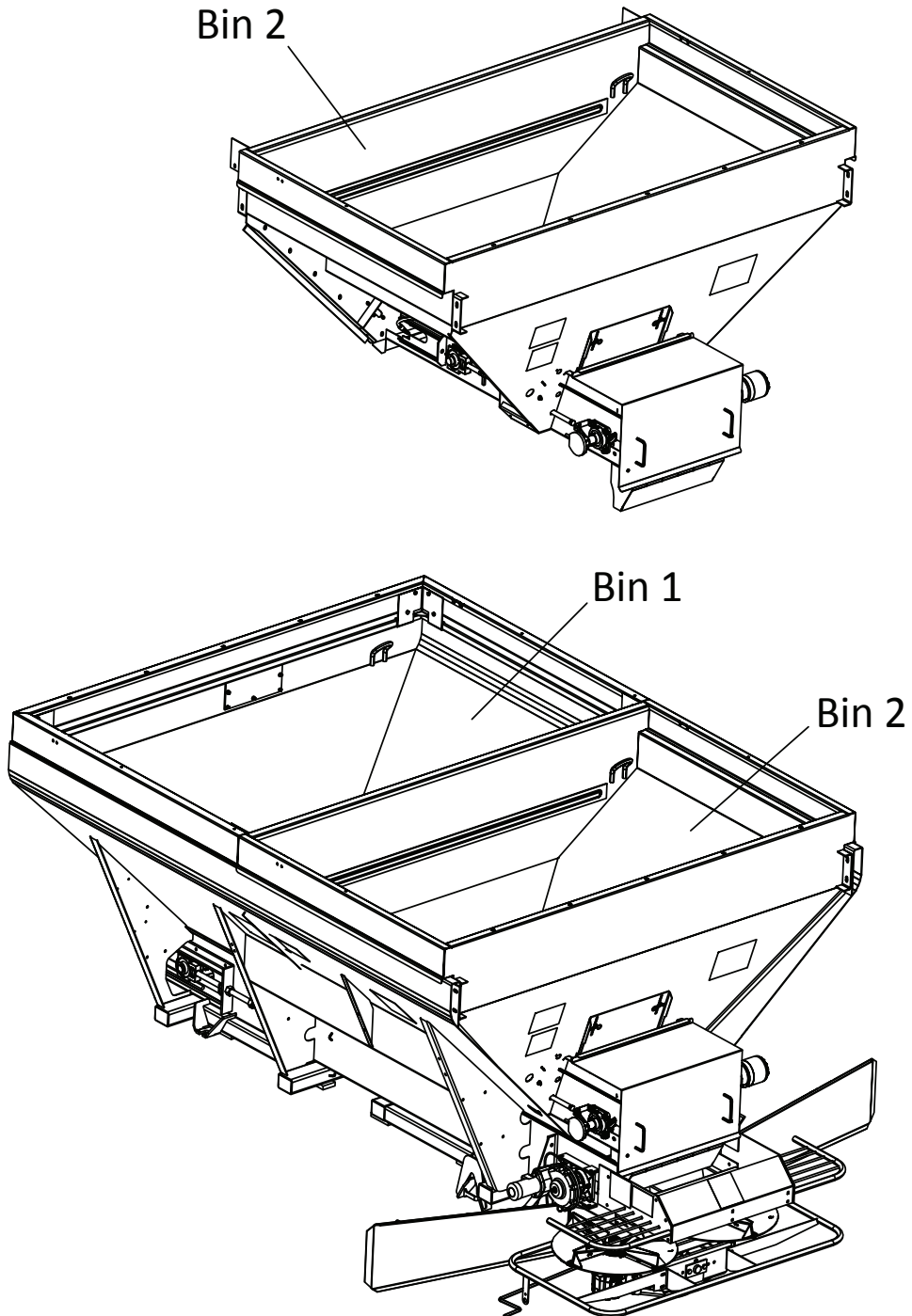

L3030G4, Single Bin

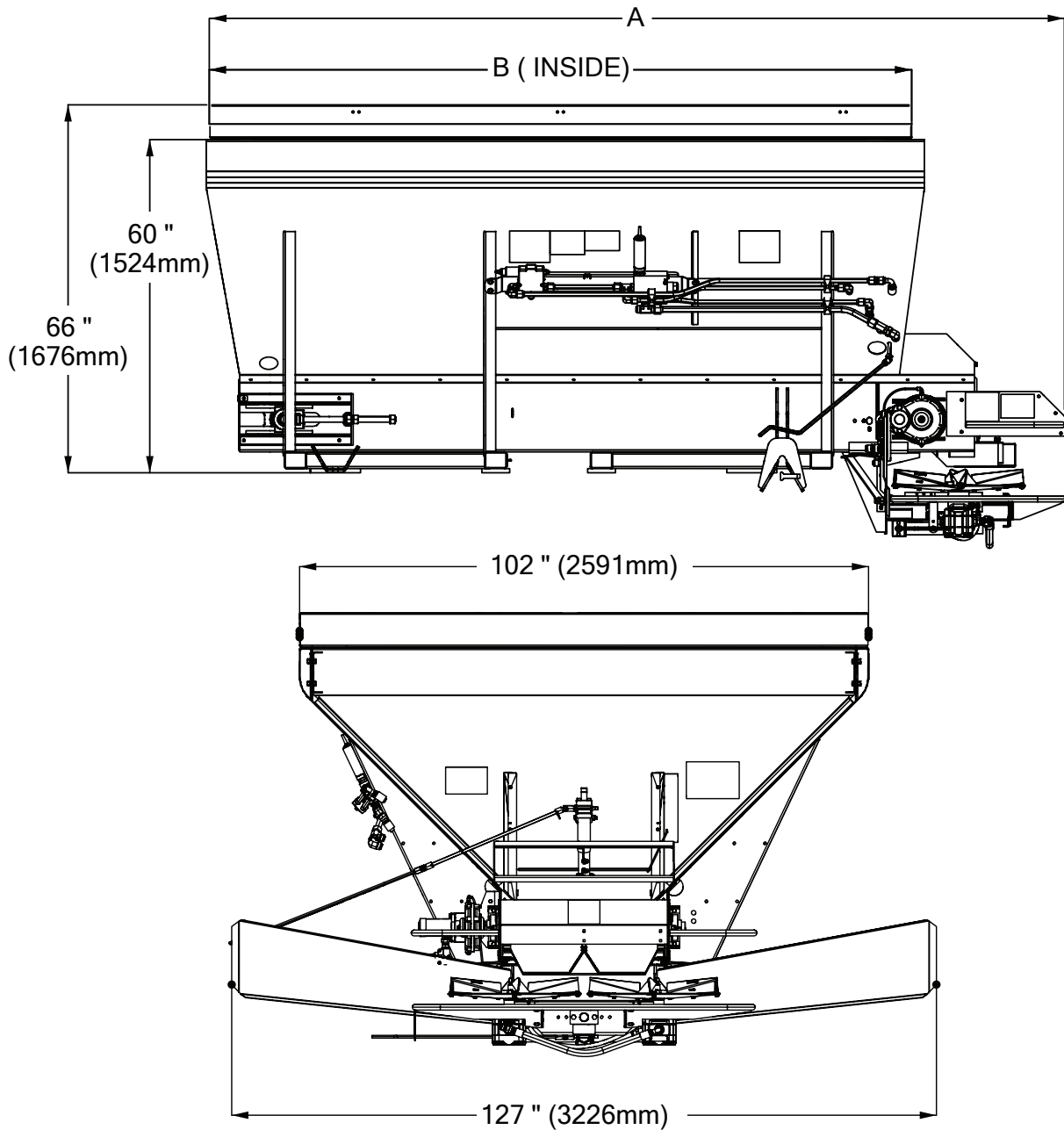

L3030G4 SINGLE BIN DIMENSIONS & CAPACITIES

Unit Length	Overall Length A	Inside Length B	Side Boards	Approximate Weight Lbs (Kg)	Struck Capacity Cu Ft (Cu M)
10.5' (3.2m)	154" (3912mm)	126" (3200mm)	With	3200 (1451)	264 (7.48)
			Without	3000 (1361)	217 (6.14)

Dimensions & Capacities

L3030G4 With MultiApplier

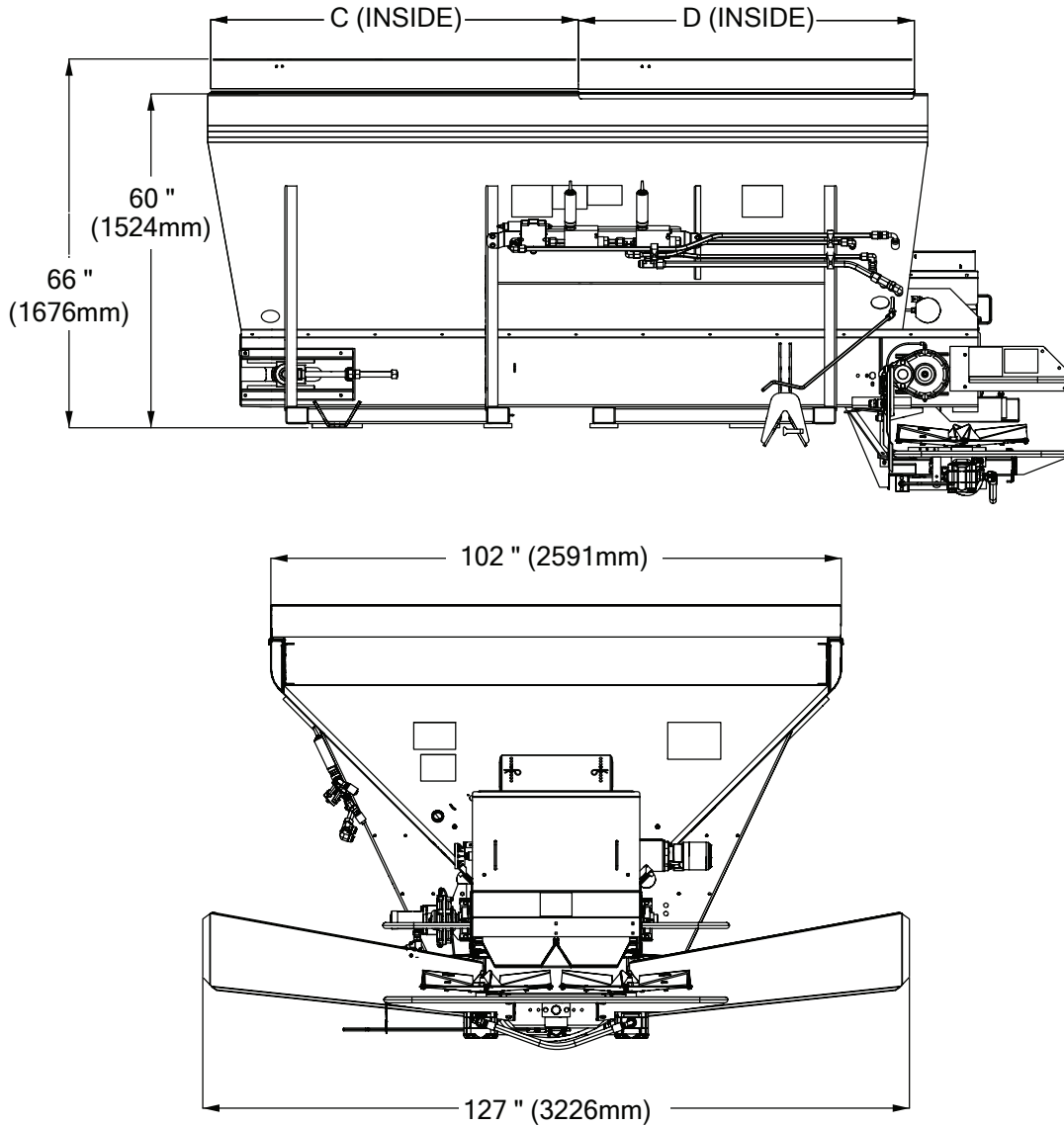

L3030G4 WITH MULTAPPLIER DIMENSIONS & CAPACITIES

Approximate Weight Lbs (Kg)	Inside Length C	Inside Length D	Bin 1 Struck Capacity Cu Ft (Cu M)	Bin 2 Struck Capacity Cu Ft (Cu M)
3900 (1769)	66" (1676 mm)	60" (1524 mm)	135 (3.82)	101 (2.86)

MultApplier Complete

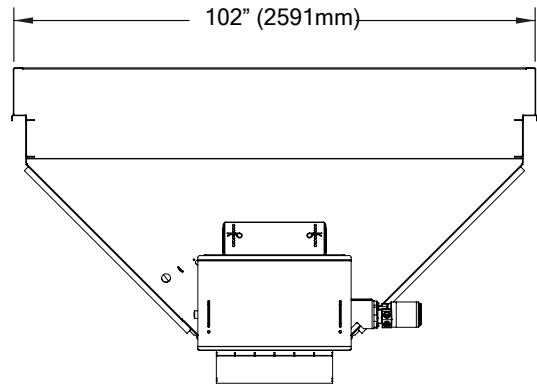
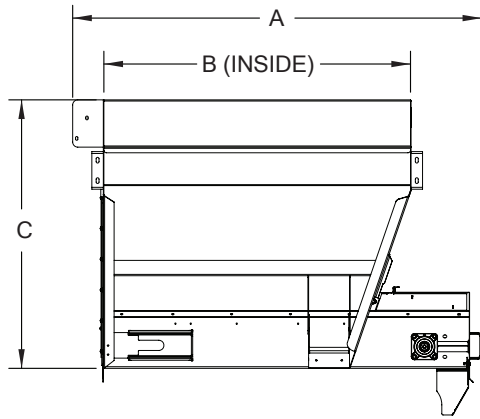

MULTAPPLIER ALONE DIMENSIONS & CAPACITIES

Insert Unit Length	Overall Length A	Inside Length B	Height C	Approximate Weight Lbs (Kg)	Struck Capacity Cu Ft (Cu M)
5' (1.52m)	74" (1880 mm)	60" (1524 mm)	53" (1346 mm)	1100 (499)	100 (2.8)



WARNING Stand clear of moving machinery.

NOTE: Do not load spreader with material.

1. Check entire unit to make sure all fasteners are in place and properly tightened per "Standard Torques" in this manual.
2. Make sure no other persons are in vicinity of spreader.
3. Make sure no loose parts are in unit or on conveyor or spinner.
4. Check oil level in hydraulic reservoir; fill as necessary.
5. Start engine and turn on hydraulics. Run hydraulic system to bring oil up to operating temperature.
6. Run spinner only at 300RPM. Allow to run until spinner is operating smoothly and all air has been purged from system.
7. Run conveyor at 20RPM and spinner at 300RPM. Run until conveyor is operating smoothly.
8. Run conveyor at 20RPM and spinner at 700RPM. Allow both conveyor and spinner to run until operating smoothly.
9. Run conveyor at 0RPM and spinner at 0RPM. Make sure both conveyor and spinner do not move.
10. Calibrate spreader as defined in the manual for the controller that is supplied with your machine.
11. Complete spread pattern test per "Spread Pattern Testing" in this manual.
12. Shut system down.



WARNING

DO NOT check leaks with hands while system is operating as high pressure oil leaks can be dangerous! If skin is pierced with hydraulic fluid at high pressure seek immediate medical attention as fluid injected into the skin could cause gangrene if left untreated. Relieve pressure before disconnecting hydraulic lines or working system. Make sure all hydraulic fluid connections are tight and all hydraulic hoses and lines are in good condition before applying pressure to the system. Wear protective gloves and safety glasses or goggles when working with hydraulic systems.



WARNING

DO NOT check for leaks adjacent to moving parts while system is operating as there may be danger of entanglement!

13. Check all connections in hydraulic system to make sure there are no leaks.

G4 SPINNER SQUARING

The squareness of the G4 Spinner Assembly and supporting parts plays a critical role in obtaining acceptable spread patterns. It is highly recommended that measurements are checked before spreading with a new unit, and any time after service or repair work has been performed on any part affecting spread patterns.

1. Figure 1 - Begin by ensuring that the Spinner Assembly is mounted correctly. The Spinner Frame should be sitting on top of/inside the Sill flanges, NOT hanging below.

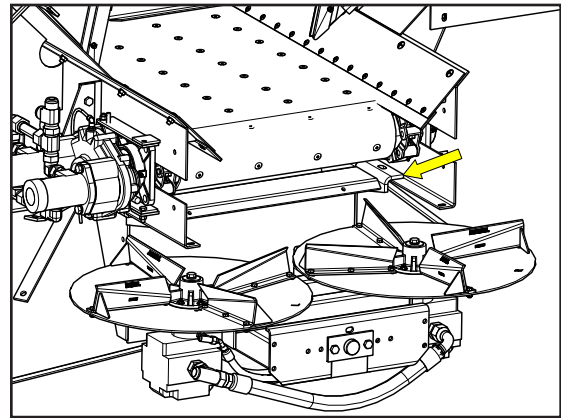

Figure 1

2. Figure 2 - Measure from the Spinner Frame mounting flange to the end of the Sill on each side. Measurement should be $9\text{-}7/8''$ (25cm). Measurements must be equal, or no greater than $1/8''$ (0.3cm) off overall.

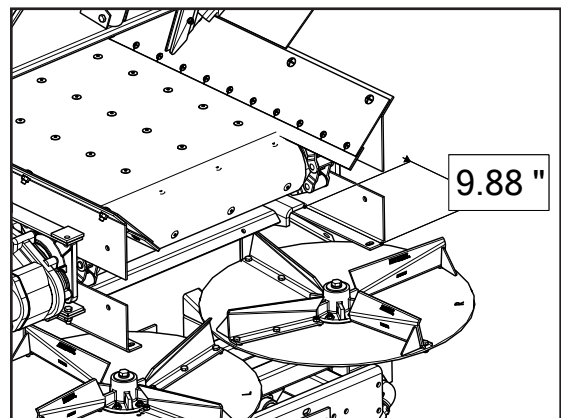

Figure 2

- Figure 3A - 3B - Check Spinner Assembly squareness by measuring from top edge of left hand Sill to inner hex flat on right hand Spinner Hub bolt. Repeat for opposite side.

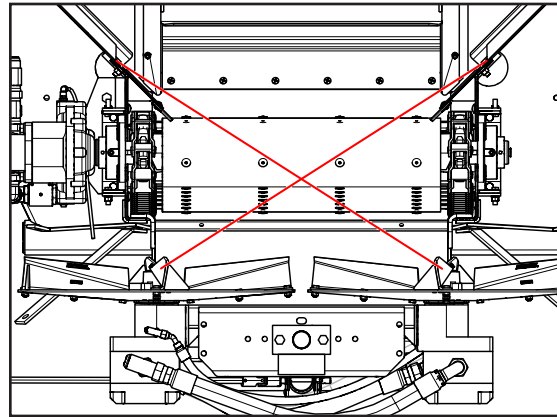

Figure 3A

- Measurements must be equal, or no greater than 1/8" off overall.

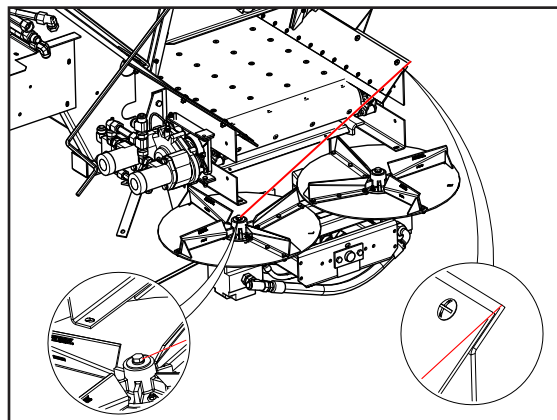

Figure 3B

- Figure 4 - If adjustments are necessary, loosen the four 1/2" carriage bolts and adjust assembly as necessary. Once corrected, tighten hardware to recommended torque. See "Standard Torques" for details.

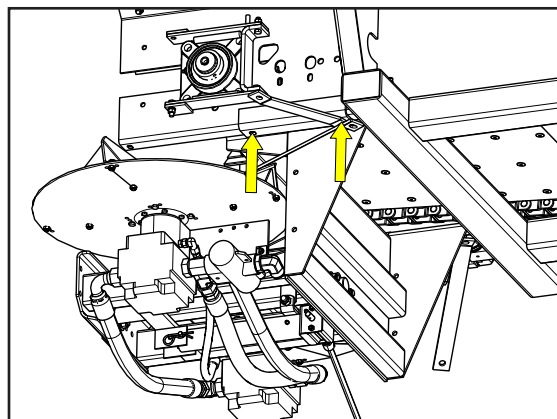

Figure 4

6. Figure 5 - Center Material Divider by measuring from the right hand inner drop-off point to the inner hex flat on the right hand Spinner Hub Bolt. Repeat measurement on opposite side. Measurements must be equal, or no greater than 1/8" off overall.

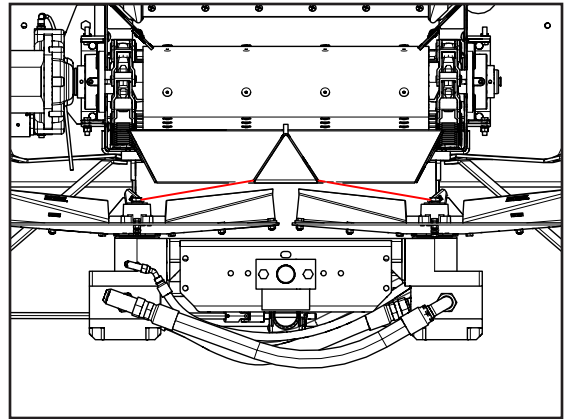

Figure 5

7. Figure 6 - Measure on each side from Spinner Frame back plate to forward drop-off point on Material Divider. Both measurements must be 12-1/4" (31cm) or no greater than 1/8" (0.3cm) off overall.
8. If adjustments are necessary, loosen the 3/8" capscrews on each side and adjust as necessary. Once corrected, tighten hardware to recommended torque.

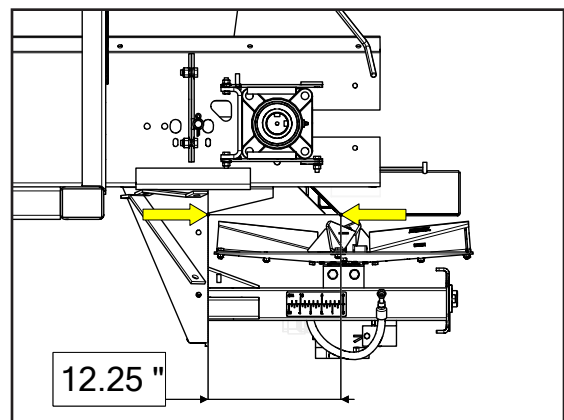

Figure 6

9. Figure 7 - If equipped, Ensure the Hillside Divider is mounted squarely and centered at both the front and the rear. Hillside Divider panel should be perpendicular to ground. Ensure the rear of the panel is centered over the center section of the Material Divider.

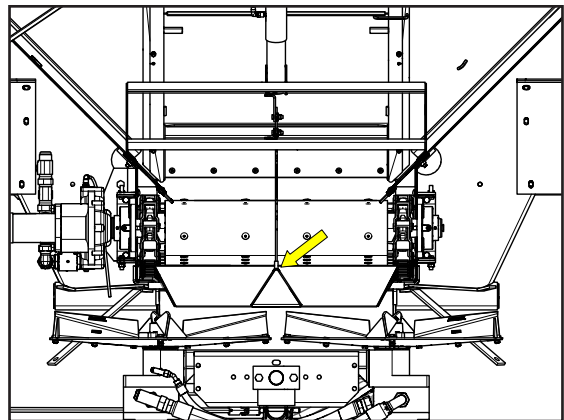

Figure 7

10. Figure 8 - Center the front of the Hillside Divider by measuring from the divider panel to the point of contact between the shield and the conveyor on each side. Measurements should be equal.

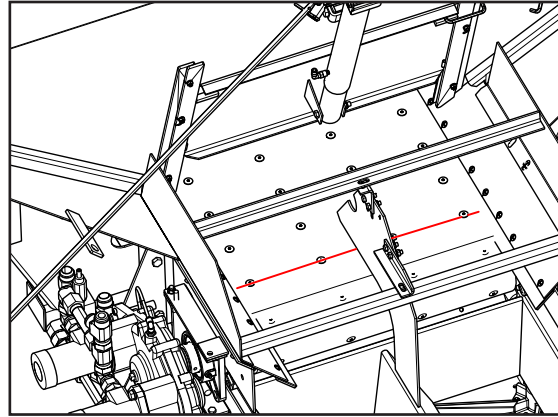

Figure 8

11. Figure 9 - Lastly, ensure that the Hillside Divider panel has proper clearance from the belt. The bottom edge of the divider panel should be approximately 3/8" (1cm) from the rubber belting of a #4 BOC.
12. If adjustments are necessary, loosen the hardware at the Hillside Divider panel as required and adjust as necessary. Once corrected, tighten hardware to proper torque.

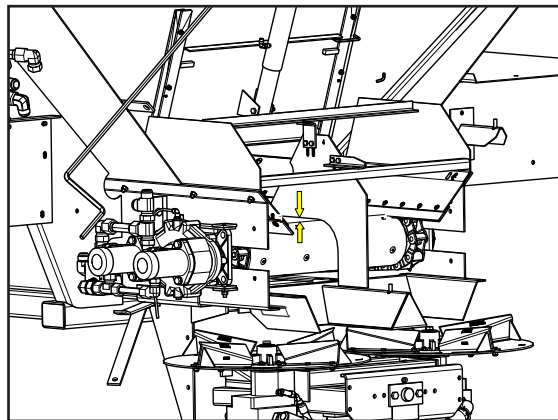

Figure 9

13. Figure 10 - Ensure all guards and shields are securely in place.

The spreader is now ready for field testing.

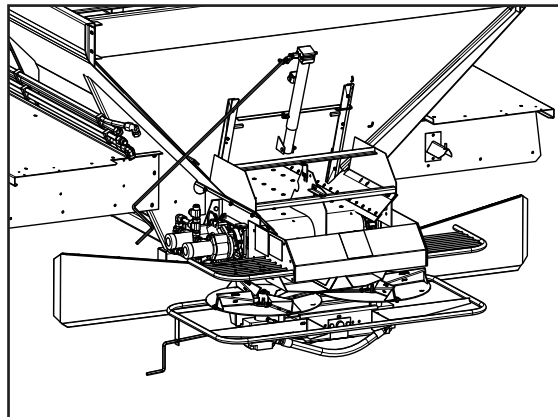

Figure 10

The following procedure is a guide:

NOTE: Do NOT fill spreader with material

1. Field test over any suitable course which allows vehicle to be driven at speeds to be used while spreading.
2. Ensure unit has been properly serviced, that the hydraulic reservoir is full. Do not load spreader.
3. Run spinners at 500 RPM.



DANGER

Take proper safety precautions when observing conveyor and spinner speed while vehicle is in motion! These may include use of suitable mirrors clamped to permit observation by a safely seated observer, following the spreader in another vehicle at a safe distance, or other suitable means. Do not stand on fenders, in body or on any part of spreader as there is danger of falling off the vehicle or into moving parts! Use great care in performing this test!

Start engine. Turn control to "on" position. Engage hydraulics and allow to run at fast idle long enough to bring hydraulic oil up to operating temperature. Spinners should revolve at moderate speed and the conveyor should not move.

Refer to controller's operation manual for conveyor operating instructions.

Set program to operational mode and begin forward travel. Move conveyor switch to "on" position. Conveyor should start immediately when vehicle moves and should continue to run at speeds which should vary directly with the vehicle's ground speed; the conveyor should speed up as vehicle speed increases and slow down as vehicle speed reduces. Spinner speed should remain constant when engine speed is above minimum operating range.

1. Make sure unit has been properly serviced and is in good operating condition. It is highly recommended to run the spreader prior to loading material to ensure acceptable operation.
2. Program controller with correct data for material(s) and application.
3. Adjust feedgate to appropriate setting.*
4. Adjust spinner to give spread pattern desired. Calibrate and spread pattern test for any new material.
5. Fill applicable bins with material to be spread.
6. Engage hydraulics.
7. Begin spreading.



CAUTION Drive only at speeds which permit secure control of vehicle.

*Visit newleader.highwayequipment.com/calculators/yield-output for interactive tools to calculate yield, proper feedgate opening, conveyor revolutions per minute and mph to maximize the performance of your spreader.

PREVENTATIVE MAINTENANCE PAYS!

The handling and spreading of commercial fertilizers is a most severe operation with respect to metal corrosion. Establish a frequent, periodic preventative maintenance program to prevent rapid deterioration to spreading equipment. Proper cleaning, lubrication and maintenance will yield longer life, more satisfactory service and more economical use of your equipment.

**WARNING**

Shut off all power and allow all moving parts to come to rest before performing any maintenance operation.

HYDRAULIC SYSTEM

Proper oil in the hydraulic system is one of the most important factors for satisfactory operation. Utmost cleanliness in handling the oil cannot be stressed enough. Keep hydraulic oil in original closed containers, clean top of container before opening and pouring, and handle in extremely clean measures and funnels.

**WARNING**

DO NOT check leaks with hands while system is operating as high pressure oil leaks can be dangerous! If skin is pierced with hydraulic fluid at high pressure seek immediate medical attention as fluid injected into the skin could cause gangrene if left untreated. Relieve pressure before disconnecting hydraulic lines or working system. Make sure all hydraulic fluid connections are tight and all hydraulic hoses and lines are in good condition before applying pressure to the system. Wear protective gloves and safety glasses or goggles when working with hydraulic systems.

**WARNING**

DO NOT check for leaks adjacent to moving parts while system is operating as there may be danger of entanglement!

HYDRAULIC HOSE

Hose assemblies in operation should be inspected frequently for leakage, kinking, abrasion, corrosion or other signs of wear or damage. Worn or damaged hose assemblies should be replaced immediately.



WARNING

Testing should be conducted in approved test stands with adequate guards to protect the operator.

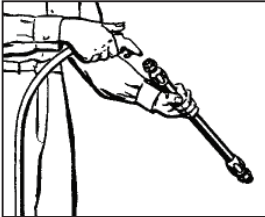

Clean

Clean assembly by blowing out with clean compressed air. Assemblies may be rinsed out with mineral spirits if the tube stock is compatible with oil, otherwise hot water at 150°F (65.55° C) maximum may be used.

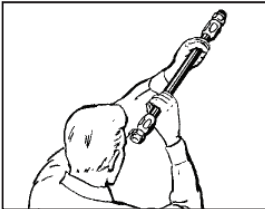

Inspect

Examine hose assembly internally for cut or bulged tube, obstructions, and cleanliness. For segment style fittings, be sure that the hose butts up against the nipple shoulder; band and retaining ring are properly set and tight, and segments are properly spaced. Check for proper gap between nut and socket or hex and socket. Nuts should swivel freely. Check the layline of the hose to be sure the assembly is not twisted. Cap the ends of the hose with plastic covers to keep clean.

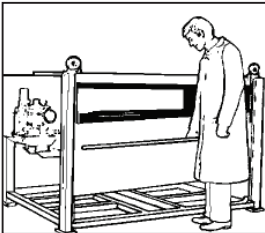

Test

The hose assembly should be hydrostatically tested at twice the recommended working pressure of the hose.

Test pressure should be held for not more than one minute and not less than 30 seconds. When test pressure is reached, visually inspect hose assembly for: 1. Any leaks or signs of weakness. 2. Any movement of the hose fitting in relation to the hose. Any of these defects are cause for rejection.

Storage and Handling

Hose should be stored in a dark, dry atmosphere away from electrical equipment, and the temperature should not exceed 90° F (32.22° C).

#5 STRAIGHT BELT CONVEYOR



WARNING

Stay out of the spreader. If it's necessary to enter the spreader, return to the shop, empty body, turn off all power, set vehicle brakes, lock engine starting switch and remove keys before entering. Tag all controls to prohibit operation. Tags should be placed, and later removed, only by person working in the body.

MAINTENANCE

The conveyor belt should be checked daily for proper tension and tracking. See "Adjustment" section.

Do not be alarmed as sides of belt wear unless belt is out of track. The belt will continue to operate satisfactorily with up to 1" (2.54cm) total worn from the sides. Inspect belt lacing frequently for wear or

“raveling” of belt grip area and loosening hardware. Retighten loose nuts and peen end of lacing screw into slot of nut as required.

ADJUSTMENT



WARNING

Moving part hazard. To prevent death or serious injury, turn off engine before adjusting. Keep hands, feet, hair and clothing away from moving parts.

Tension

NOTE: Belt tension should be just tight enough to prevent slippage—no tighter.

1. Figure 1 - For a new conveyor belt, square idler turnkleen with conveyor bottom by loosening jam nuts and adjusting take-up bolts (A). Measure to ensure Measurement “B” is equal on each side.
2. Figure 2 - With the conveyor shut off, measure vertical distance from bottom of sill to conveyor belt in front of second cross tube from front. Measurement “A” is to be 3” (8cm) on each side.
3. Adjust idler screws (A) as necessary to obtain Measurement “A”.

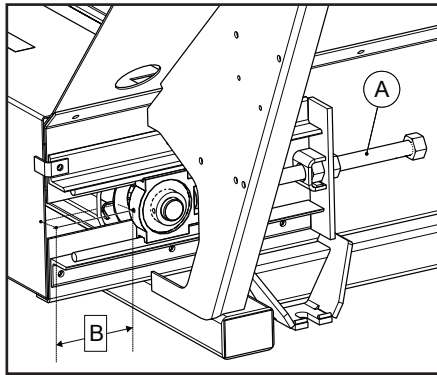

Figure 1

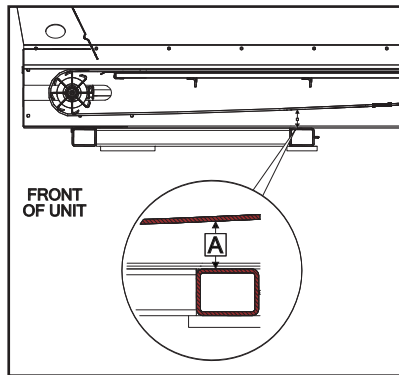

Figure 2

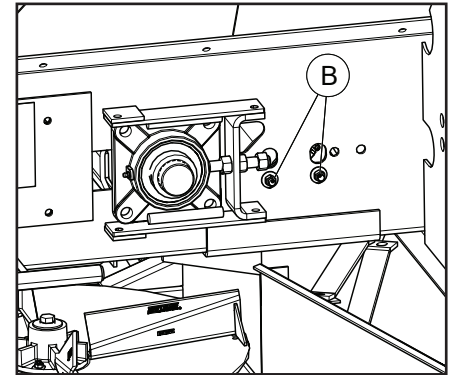

Figure 3

Tracking

NOTE: Once belt is properly tracked, Measurement "B" in Figure 1 may not be equal on each side. This is acceptable.

1. Spreader must be empty of material.
2. Figure 3 - Snubber pulley must be secure and square to conveyor bottom. Verify bearings are equally positioned in height adjustment between each side. Loosen hardware (B) and adjust as necessary.
3. Start engine. Engage hydraulics and turn on conveyor. Start at slow speed, and slowly increase conveyor speed while continuously monitoring belt tracking.
4. Continue to increase speed until maximum conveyor speed is achieved (approximately 50 conveyor pulley RPM).
5. If further tracking adjustments are required, continue to troubleshooting on next page.

Improper tracking is usually due to one of three basic causes. These problems and their respective solutions follow:

PROBLEM 1: (Figure 5)

Belt tracks to one side, contacts side of conveyor. Contact is more severe at the front and may not quite touch at the rear.

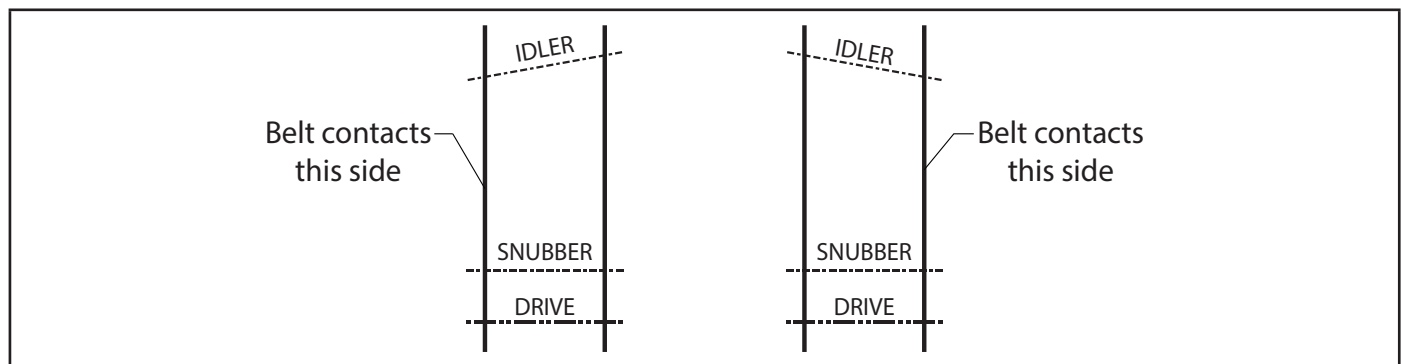

Figure 5

SOLUTION:

Tighten idler take-up on side in contact with belt. Make this adjustment one turn at a time. Operate conveyor 10 to 15 minutes at a high speed to allow belt to react to the adjustment. Repeat if necessary.

PROBLEM 2: (Figure 6)

Belt contacts one side at front and contacts other side at rear.

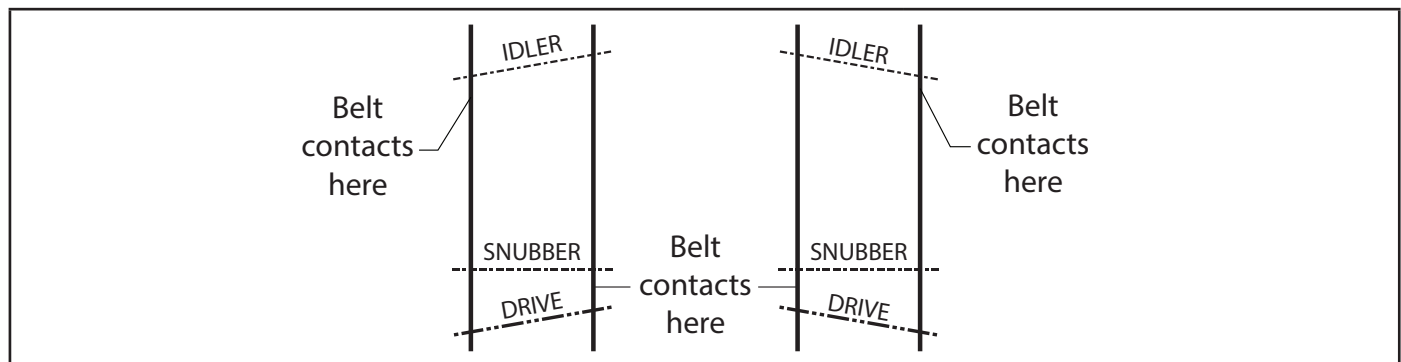

Figure 6

SOLUTION:

If Solution to Problem 1 does not remedy the situation, adjustment of the drive pulley is necessary. Mark the position of the adjustment screw (C) on the right hand side of the unit as shown in Figure 7. Determine which illustration in Figure 6 shows the problem to figure out which direction the drive shaft needs to move. Loosen the adjustment screw to move the right-hand end of the shaft forward; tighten the screw to move the right-hand end of the shaft rearward. NOTE: The illustration is exaggerated. Only move the adjustment screw 1/4 turn at a time after loosening the bolts holding the bearing. Usually, 1/64 (.04cm) to 1/32 (.08cm) inch adjustment is all that is necessary. Retighten bearing. Operate conveyor for 10 to 15 minutes at a high speed to allow belt to react to adjustment. The problem should change to Problem 1. Adjust as in Problem 1 to track belt properly.

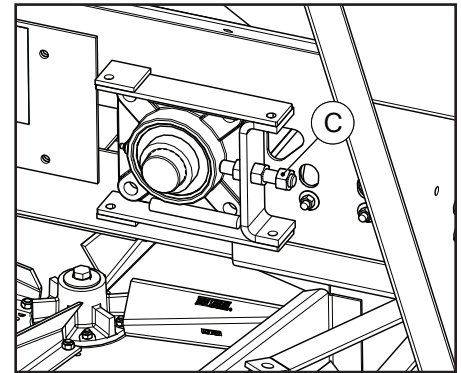

Figure 7

PROBLEM 3: (Figure 8)

Belt contacts side as in Problem 1, but contacts more heavily at a point approximately three feet from rear.

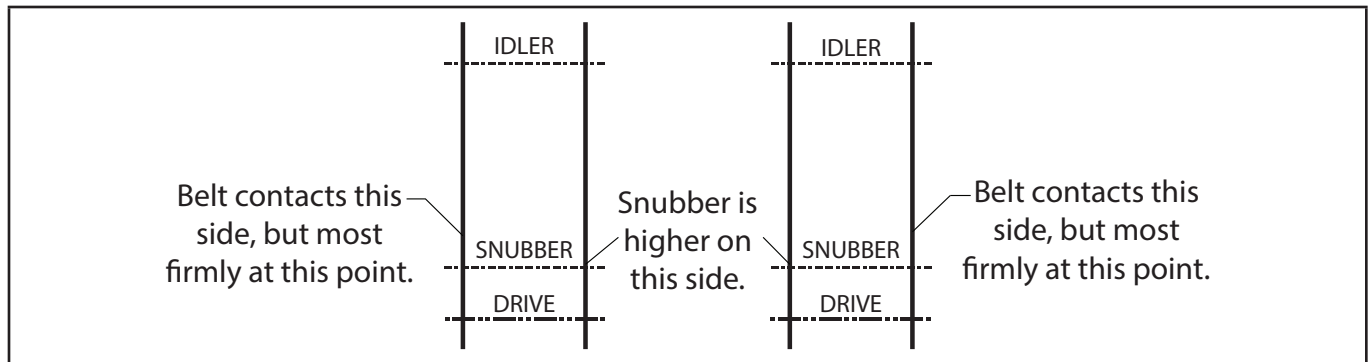

Figure 8

SOLUTION:

Realign snubber pulley. Note the point or side of contact from the illustration. This side of the snubber is too low.

NOTE: This pulley moves up and down ONLY.

Loosen belt and raise or lower as necessary. Loosen the two bolts holding the snubber bearing on the side to be adjusted after marking the old position. Move approximately 1/16 (.16cm) inch at a time and retighten. Retighten belt the exact number of turns previously loosened. Operate conveyor 10 to 15 minutes to allow belt to react to adjustment. Refer to Problem 1 and readjust. If readjustment does not compensate, repeat. If, after continued adjustment, the belt does not track properly, check the following:

1. Check for twisted spreader body. Shims must be placed between spreader cross tubes and the mounting surface to eliminate any twist in the body structure.
2. Check for crowned Idler Pulley by placing a straight edge on the pulley. If properly crowned, the straight edge will contact the center pulley leaving 1/16 (.016cm) inch gap between the straight edge and both pulley ends. Replace the pulley if crown is not present.
3. Check for lacing squareness by removing the belt. This should be done as a last resort. If the lacing is not square to the belt ends, contact your local New Leader dealer for service.
4. Sight down the body under the belt shields. The only point which should come close to, or slightly contact the belt, is the lowest point on the shield. If the belt contacts the shield firmly at any other point, tracking will be impossible. See your local New Leader dealer immediately.

BELT SHIELDS

The belt shields, located along each side of the belt inside the unit, should be just contacting the belt when the belt is properly adjusted and the hopper is empty (Figure 9). If a shield has clearance along its length, it can be adjusted until it just contacts the belt by loosening the fastener bolts, allowing the shield to slide downward and tightening the bolts. If the shield tends to cut into the belt along its full length, loosening the bolts and raising the shield until it just contacts the belt will correct the problem.

If the shield cuts the belt at one or more points or if it gaps at one or more points, it should be replaced.

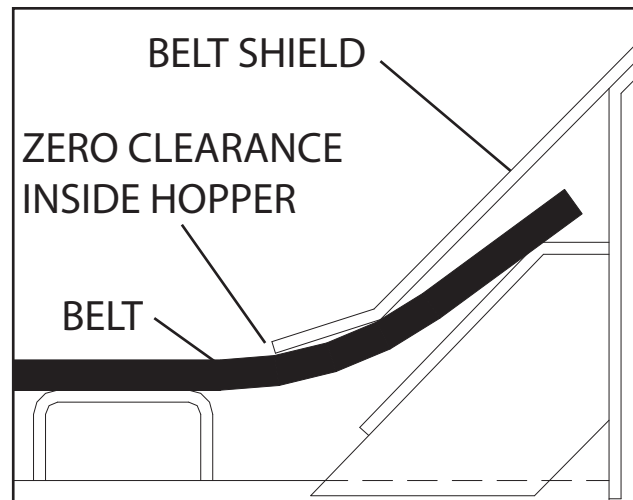

Figure 9

NOTICE! Do NOT lubricate the #5 belt. Use of lubricants will cause the belt to deteriorate and fail prematurely.

REMOVAL & REPLACEMENT

Tools and Equipment Required (NOTE: Two people MUST be used for this procedure.):

1. 1-1/2" Hex Wrench
2. 25 to 30 Feet (8m – 9m) of 1/4" (.64cm) to 3/8" (.95cm) Rope.
3. 3 or 4 Pieces of 2 x 4 (5cm x 10cm) Lumber about 3 Feet (1m) Long.
4. 10 Feet (3m) of 14 or 16 Gauge Soft Iron Wire.

Procedure:

1. Unplug the PWM valve to disable spinners.
2. Remove both belt shields, clean thoroughly and repaint as necessary.
3. Adjust controller to Manual operation. Select a slow manual speed so tracking is visual.
4. Run conveyor until belt splice is accessible at rear of spreader. Shut machine down and remove key.
5. Loosen the front idler adjustment screws all the way.
6. Pull out splice pin to separate belt splice.
7. Insert pin into one side of belt splice. Attach a winch to the belt splice and remove belt.
NOTE: If the splice pin cannot be removed, cut belt and remove belt by hand.
8. Remove any caked material from the drive pulley, snubber pulley, idler pulley and from inside the frame channels. Clean and repaint as necessary.
9. Thread OLD splice pin through one end of splice on new belt. Connect wire to pin about 1/4" (.64cm) in from each side of the belt, forming a loop.



CAUTION Moving part hazard. To avoid injury, shut off engine before performing threading rope.

10. Figure 10 - Thread the rope along the top of the belt channel, around the front idler pulley, over the snubber pulley, and beneath the drive pulley.
11. Tie end of rope under drive pulley to wire loop. Wrap other end of rope once around drive pulley and out to rear.
12. Start conveyor drive so drive pulley turns slowly. One person should pull on rope while other feeds belt into unit from rear. Pull new belt under drive pulley, over snubber pulley, along frame channels, around front idler pulley and back to drive pulley.



CAUTION Use extreme care to avoid entanglement! Someone must stay at controls to stop conveyor immediately if required.



CAUTION Use extreme care to avoid entanglement! Stand well back from drive pulley.

13. Shut off all power and insert lumber under belt to support its weight as shown in Figure 9.
14. Insert a plastic tube in each splice and across the full width of the belt and pull the two ends together at the center of the rear face of the drive pulley.
15. Insert the splice pin (flexible, plastic covered).
16. Snug the belt up by tightening the idler pulley.
17. Tighten the belt until the edge of the belt is approximately 3" (76mm) above the lower edge of the sill lower flange on each side. Remove lumber.
18. Adjust for proper tracking as outlined in the Belt Conveyor Adjustment section of this manual.

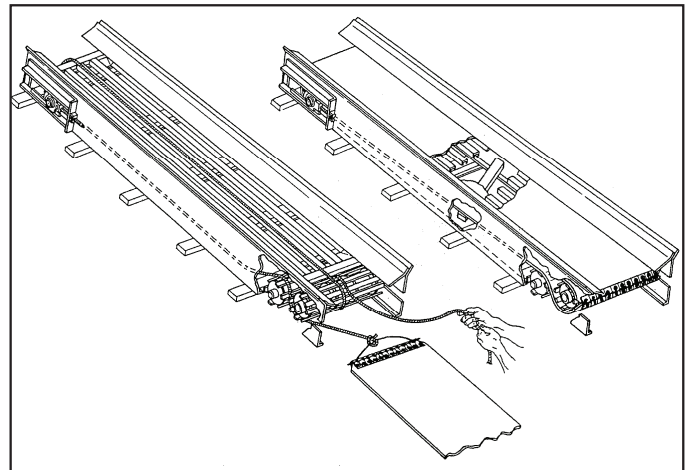

Figure 10- #5 Belt Installation

#4 CONVEYOR CHAIN - BIN 2

Hose down unit and remove any material build-up on sprockets and under chain.

NOTICE!

The conveyor will move away from the bottom panel if material accumulates under the conveyor or on the sprockets. The more material that accumulates, the closer the chain will come to the chain shields. If the conveyor should catch a chain shield, it could permanently damage the conveyor, the chain shields or the unit. Do not remove material while conveyor or spinner is running!

Lubrication

Make sure unit is clean and completely dry. Lubricate insert conveyor chain at the end of each week or after 40 hours of operation, whichever ever occurs first.

Shut down spinner and run conveyor at 20 RPM for two full revolutions to lubricate chain. After each unit washing, allow to dry, then lubricate each chain strand at rear of unit using a pressurized garden sprayer. Refer to "Lubricant & Hydraulic Oil Specifications" for recommended lubricants.

Tension

Figure 11 - Proper chain tension is also a factor in chain and sprocket life. Measure from rear of unit forward to achieve proper chain tension. Make sure chain is tensioned equally on both sides. This adjustment is made on each side of the unit at the idler bearings.

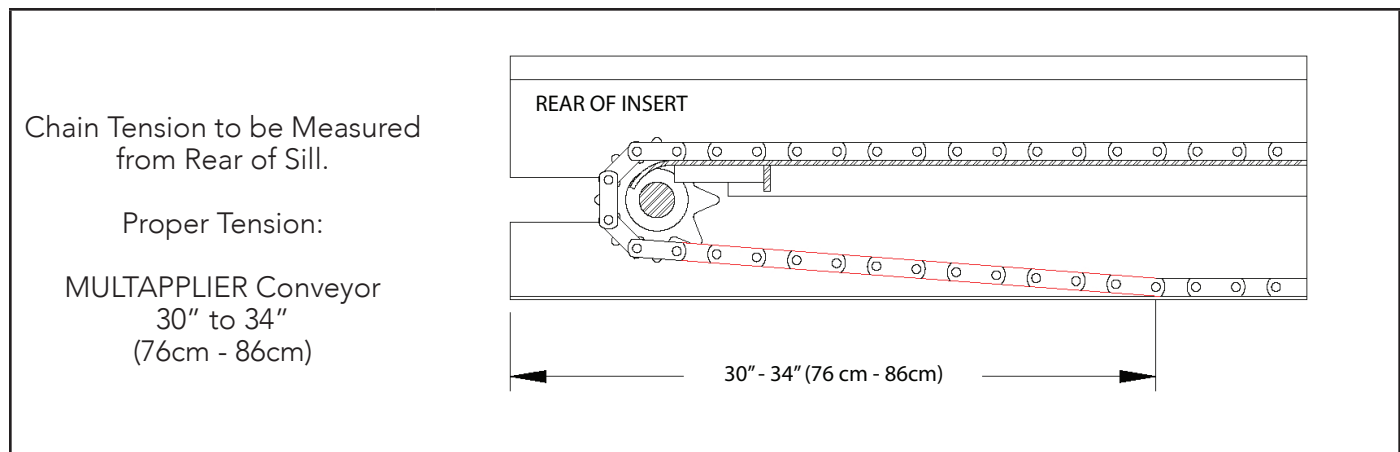

Figure 11 - Chain Tension

Conveyor chains that are too tight will tend to stretch, causing excess sprocket wear and eventually breakage. Excess slack presents the possibility of chain catching on sub-frame parts. Bent or distorted chain bars will cause damage as well. Straighten or replace bent or distorted chain bars immediately.

CONVEYOR GEARCASE

Drain oil in a new unit after first two weeks (or not more than 100 hours) of operation, and flush gear case thoroughly with light oil. Refer to "Lubricant and Oil Specifications" section for proper grade oil and recommended amounts of lubricant. After initial change, oil should be changed every 2,000 hours of operation or annually, whichever occurs first.

Check gearcase oil level monthly.

BIN SENSOR

**WARNING**

Stay out of the spreader. Do not climb on spreader. Use a portable ladder to inspect, clean and maintain the bin sensor from outside the spreader. Failure to do so could result in injury from falling.

NOTICE!

Wipe sensor clean periodically to prevent accumulation of product. Avoid wet material as it may stick to sensor. If material sticks to sensor it won't warn user when bin is low.

Clean sensor with long handled brush or hose from outside of spreader. Do not aim high pressure sprayer directly at sensor—it could damage the components.

LUBRICATION OF BEARINGS

Grease in a bearing acts to prevent excessive wear of parts, protects ball races, and balls from corrosion and aids in preventing excessive heat within the bearing. It is very important the grease maintain its proper consistency during operation. It must not be fluid and it must not channel.

Make sure all fittings are thoroughly cleaned before grease is injected. Points to be lubricated by means of a grease gun have standard grease fittings.

Lubricate bearings by pumping grease slowly until it forms a slight bead around the seals. This bead indicates adequate lubrication and also provides additional protection against the entrance of dirt.

FASTENERS

Tighten all screws fasteners to recommended torques after first week of operation and annually thereafter. If loose fasteners are found at anytime, tighten to recommended torque. Replace any lost or damaged fasteners or other parts immediately. Check body mounting hardware every week.

CLEAN-UP

NOTICE!

High pressure wash can inject water and/or fertilizer into control components, causing damage. Use caution when cleaning these areas.

Thoroughly wash unit every two to three days during the operating season to maintain minimal maintenance operation. Hose unit down under pressure to free all sticky and frozen material.

It is important the unit be thoroughly cleaned at the end of each operating season. All lubrication and maintenance instructions should be closely followed. Repaint worn spots to prevent formation of rust.

Spinner Fins

Visually inspect spinner fins daily for build-up of material and wear. Spinner discs and fins must be kept clean and polished. Even a small build-up of material on a spinner can significantly affect the spread pattern. Rough, bent or worn fins will produce poor spread patterns. Replace worn fins and discs as needed. See Fin Kit Installation Instructions for replacement part numbers and instructions.

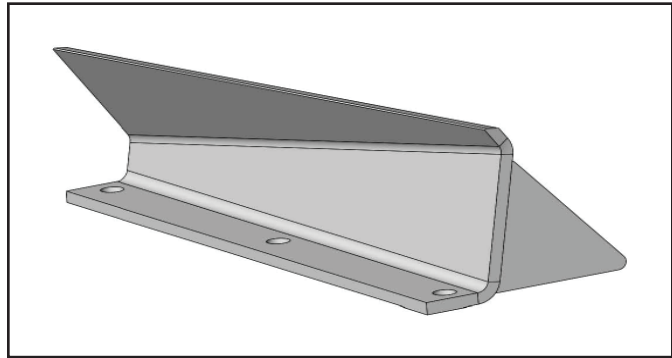

Figure A - Spinner Fin

Spinner Deflectors

Visually inspect spinner deflectors daily for build-up of material and damage. Clean as needed. Even a small build-up of material on a spinner deflector can affect the spread pattern. If damaged, bent or otherwise, replace. See parts manual for replacement part numbers.

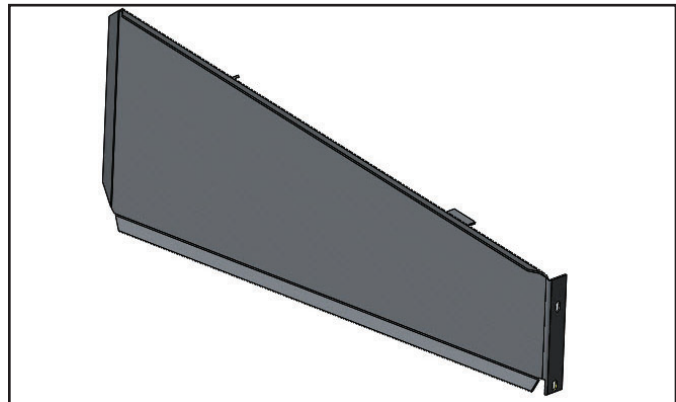

Figure B - Spinner Deflector

Material & Hillside Flow Dividers

Visually inspect material divider and hillside flow dividers (as equipped) daily for build-up of material and wear. Any build-up of material on divider components can affect performance. Clean as needed. Replace worn or damaged parts as necessary. See parts manual for replacement part numbers.

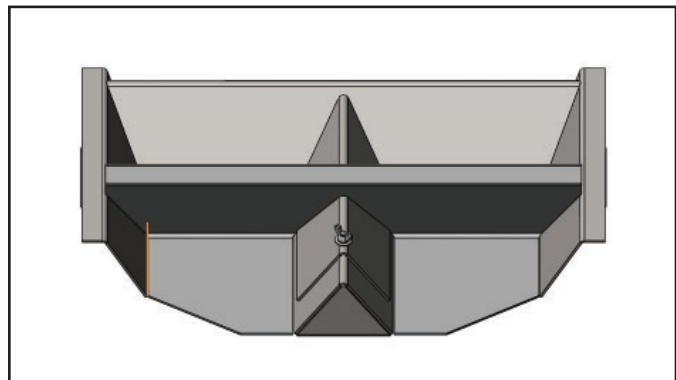

Figure C - Material Divider

HYDRAULIC SYSTEM

Use premium quality lubricants with 100-200 SUS or 20-43 cSt viscosity at operating temperatures. The hydraulic fluid's specifications in the table below are for normal operating conditions. Extreme environments or dirty conditions may require the use of different oils. Consult your New Leader dealer or the Product Support Department at Highway Equipment Company for systems operating outside normal conditions.

Ideal Oil Operating Temperature	115-158°F (46.11-70° C)
Recommended Premium Lubricant	Multi-Purpose Agriculture Hydraulic & Transmission Oil
Lubricant Specifications Viscosity Index Viscosity at 40°C, cst Viscosity at 100°C, cst	Greater than 130 Less than 68 Greater than 9
Acceptable Fluid Example	Mobil 424

GEARCASE LUBRICANT

Lubricate these assemblies with non-corrosive type extreme pressure (E.P.) gear oil conforming to MIL-L2105 B multi-purpose gear lubricating oil requirements (API Service GL 4) based on ambient temperatures listed below. Refill gear case with 1-1/2 pints (.70 liters) of recommended lubricant.

Ambient Temperature	Below 40° (4.44°C)	Between 40° (4.44°C) and 100° (37.77°C)	Above 100° (37.77°C)
Oil Type	SAE 80 E.P.	SAE 90 E.P.	SAE 140 E.P.

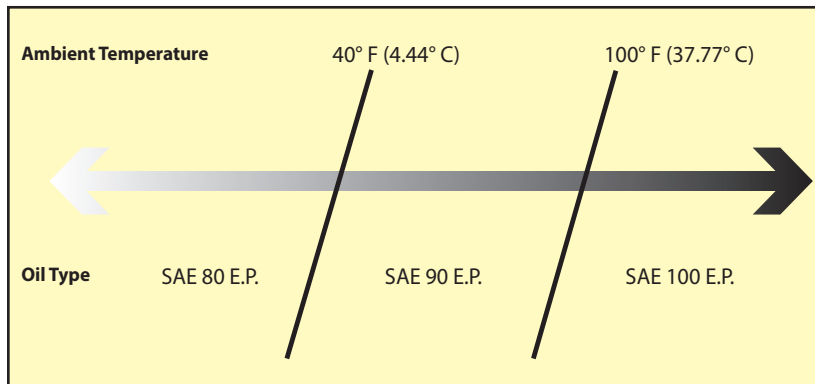

GREASE GUN LUBRICANT

Use a waterproof ball and roller bearing lithium base lubricant with a minimum melting point of 300°F (148.8° C). This lubricant should have a viscosity which assures easy handling in the pressure gun at prevailing atmospheric temperatures. The grease should conform to NLGI No. 2 consistency.

CHAIN CONVEYORS

Use a mixture of 75% No. 1 or No. 2 diesel fuel or kerosene mixed with 25% SAE 10 engine oil for periodic conveyor lubrication.

Lubricate conveyor chains with Fluid Film™ spray lubricant or equivalent at the end of each season.



WARNING

Shut off all power and allow all moving parts to come to rest before performing any maintenance operation.

The spreader should be regularly lubricated with the lubricants recommended in this manual in accordance with the following chart:

Location	Places	Method	Frequency
Conveyor			
Grease Zerks - Dragshaft Bearings (A)	2	Grease Gun	Weekly
Grease Zerks - Idler Shaft Bearings (B)	2	Grease Gun	Weekly
Take-Up Screws (C)	2	Hand Grease	Weekly
Grease Zerks - Snubber Pulley Bearings (D)	2	Grease Gun	Weekly
Gearcase	1	Gear Oil	Check Monthly; Change Annually
Bin 2 Insert Chain Conveyor Strands	2	Oil Mixture	Weekly
		Spray Lubricant	Annually
Feedgate Jack Assembly			
Grease Zerks (E)	1	Grease Gun	Annually
Spinner			
Grease Zerks - Shaft (F)	2	Grease Gun	Weekly
Grease Zerks - Jack (G)	2	Grease Gun	Weekly
Bin 2 Conveyor			
Grease Zerks - Dragshaft Bearings (H)	2	Grease Gun	Weekly
Grease Zerks - Idler Shaft Bearings (J)	2	Grease Gun	Weekly
Take-Up Screws (K)	2	Hand Grease	Annually

NOTE: Unusual conditions, such as excessive dust, temperature extremes or excessive moisture may require more frequent lubrication of specific parts.

*See "Lubricant and Oil Specifications" for types of lubricants and oil to be used.

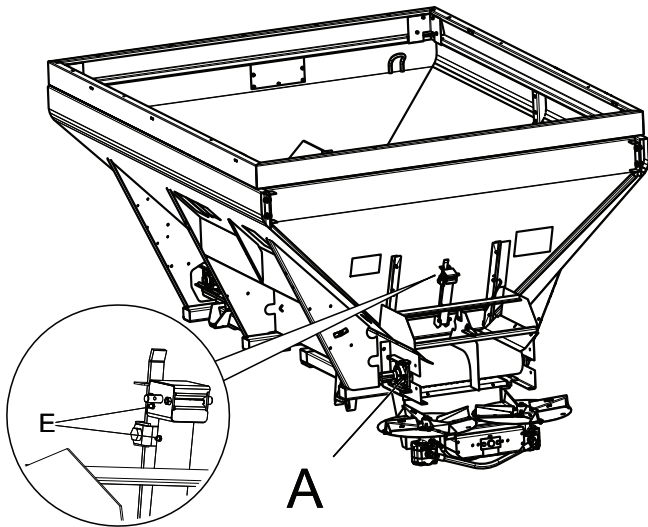

SINGLE BIN

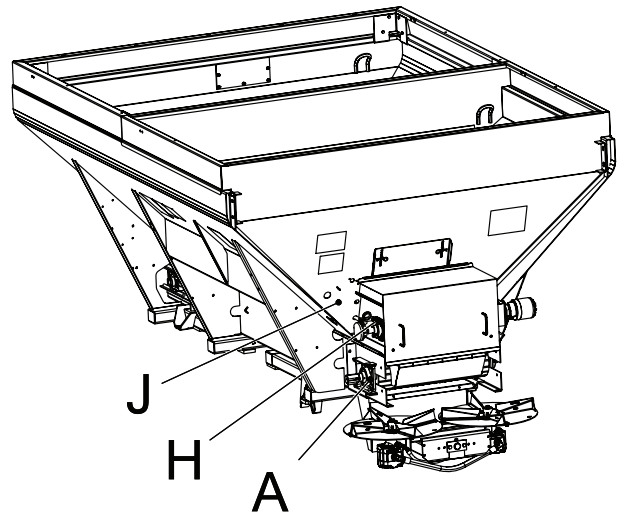

MULTAPPLIER

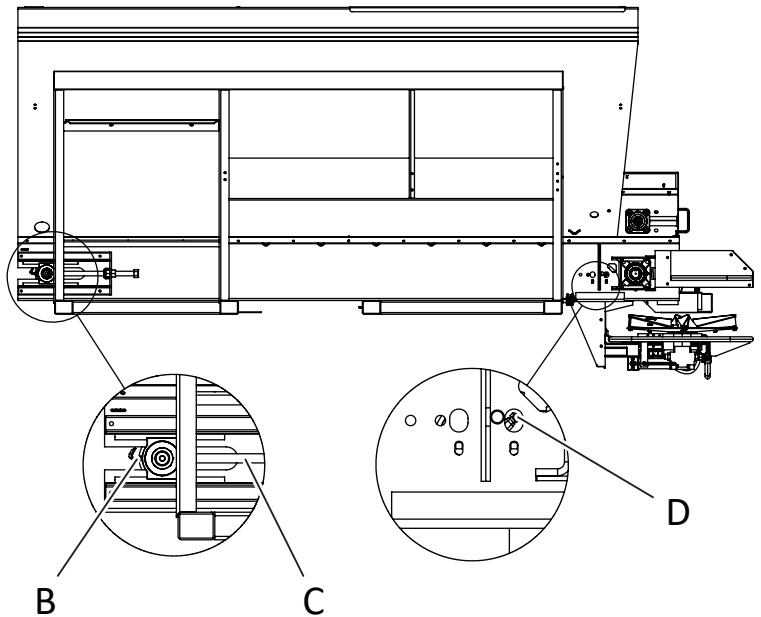
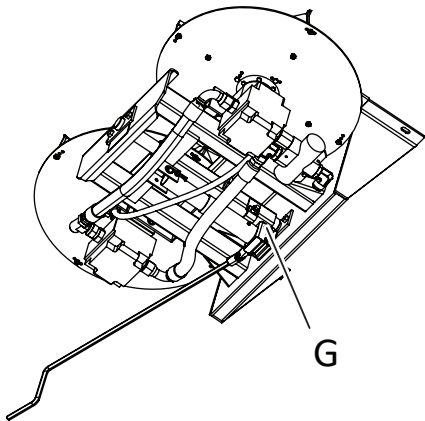

NOTE: SOME COMPONENTS HIDDEN FOR CLARITY

Symptom:	Reason:	Correction:
Spinner will not run	Defective Spinner Control Valve	Replace spinner control valve cartridge and coil.
	No voltage at valve	Verify spinner switch is on.
		Verify spinner enable is checked.
		Verify controller has a target spinner RPM entered.
		Verify spinner control harness is not damaged.
	No hydraulic flow	Verify system was configured as Basic independent.
		Verify hydraulics are on.
Pressure test pump - replace as needed.		
Spinner will not shut off	System is going over relief - test & replace as needed.	
	Defective spinner control valve	Replace spinner control valve cartridge.
Spinner runs erratic	Control valve is manually overrode	Loosen jam nut on control valve cartridge and back set screw out until spinner stops.
	Defective spinner control valve	Replace spinner control valve cartridge.
Spinner speed drops off when turning around	Spinner speed sensor harness failure	Replace sensor harness.
	Spinner speed sensor not properly installed	Adjust sensor so that gap between sensor and fin mounting bolt is less than 1/8".
	Improper control settings	Verify PWM control is set properly (HOLD for gear pumps, CONTROL for variable displacement).
Spinner speed does not hit target	Defective spinner control valve	Replace spinner control valve cartridge.
	Pump failure	Flow and pressure test pump.
	Spinner speed sensor not properly installed	Adjust sensor so that gap between sensor and fin mounting bolt is less than 1/8".
	Hydraulic flow dropping off	Adjust settings and speed. Pressure test relief (adjust or replace as needed).
	Spinner speed sensor harness failure	Replace sensor harness.
	Spinner speed sensor failure	Replace spinner speed sensor.

Symptom:	Reason:	Correction:
Conveyor will not run	Defective conveyor control valve	Replace conveyor valve cartridge.
	No voltage at valve	Verify bin switch and master switches on.
		Verify in controller that target rate, density, ground speed and a CFR number are all entered.
		Verify conveyor control harness is not damaged.
	No hydraulic flow	Verify hydraulics are on.
		Pressure test pump - replace as needed.
		System is going over relief - test & replace as needed.
Conveyor is going over relief - test & replace as needed.		
Conveyor will not shut off	Defective conveyor cartridge	Replace conveyor control valve cartridge.
	Control valve is out of time	Adjust cartridge timing.
Conveyor runs erratic	Defective conveyor cartridge	Replace conveyor control valve cartridge.
	Encoder failure	Replace encoder.
	Encoder harness failure	Replace harness.
	Rates smooting is disabled	Enable rate smoothing.
Bin will not hit target rate	Defective conveyor cartridge	Replace conveyor control valve cartridge.
	Pump failure	Flow and pressure test pump.
	Going over relief	Adjust setting and speed. Pressure test relief (adjust or replace as needed).
	Encoder failure	Replace encoder.
	Encoder harness failure	Replace harness.
Hydraulics over-heating	Pump failure	Flow and pressure test pump.
	Too much flow	Flow test pump.
	System relief	Pressure test relief (adjust or replace as needed). Adjust settings and speed.
	Conveyor valve relief	Pressure test relief (adjust or replace as needed). Adjust settings and speed.
	Oil cooler fan failure	see oil cooler fan failures.
	Case drain on mono valve is plugged.	Case drain requires zero pressure line back to tank.
Oil cooler fan failure	No power at fan	Verify FAN 30-amp fuse is not blown. Verify relay is working properly.
	Fan failure	Replace fan.

CAP SCREW GRADE IDENTIFICATION - MARKINGS ON HEAD

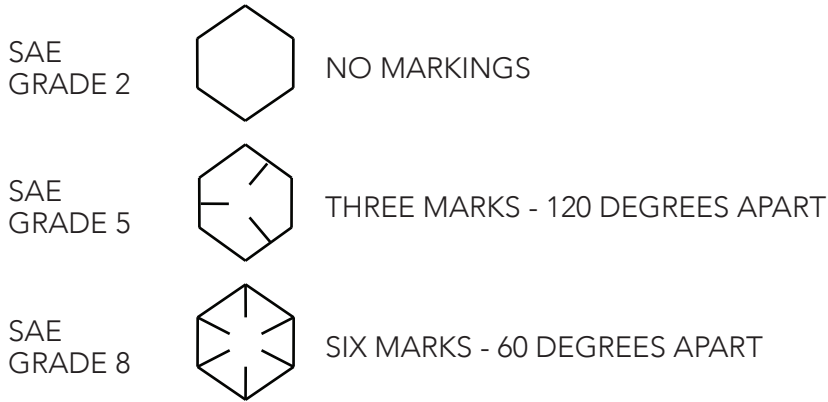

USE GRADE 2 TORQUES FOR STAINLESS STEEL FASTENERS AND CARRIAGE BOLTS.

CAP SCREW SIZE	TORQUE - FOOT-POUNDS					
	GRADE 2		GRADE 5		GRADE 8	
	DRY	LUBE	DRY	LUBE	DRY	LUBE
1/4"	5	4	8	6	12	9
5/16"	11	8	17	13	25	18
3/8"	20	15	30	23	45	35
7/16"	30	24	50	35	70	55
1/2"	50	35	75	55	110	80
9/16"	65	50	110	80	150	110
5/8"	90	70	150	110	220	170
3/4"	100	120	260	200	380	280
7/8"	140	110	400	300	600	460
1"	220	160	580	440	900	650

IMPORTANT! Do not operate or work on machine without reading and understanding the operator's manual.

Before starting engine/before starting machine operation

- | | |
|--|---|
| <input type="checkbox"/> Program rate controller and document settings | <input type="checkbox"/> Hydraulic hoses are secured properly |
| <input type="checkbox"/> All stop, tail, and turn lights function properly | <input type="checkbox"/> Gearcase oil level is correct |
| <input type="checkbox"/> Tire pressures are equal on each side of chassis | <input type="checkbox"/> Safety shields in place |
| <input type="checkbox"/> Battery condition and connection | <input type="checkbox"/> Spinner Assy moves through full range of operation |
| <input type="checkbox"/> Electrical connections are tight and secure | <input type="checkbox"/> Spinner discs and fins installed properly |
| <input type="checkbox"/> All fasteners are secure | <input type="checkbox"/> Spinner discs and fins are in acceptable condition |
| <input type="checkbox"/> Inverted "V" is secure and installed properly | <input type="checkbox"/> Material Divider assembly is square and secure |
| <input type="checkbox"/> Sensor(s) are functioning properly | <input type="checkbox"/> Material Divider is clean of build-up |
| <input type="checkbox"/> Lubricate all grease fittings | <input type="checkbox"/> Feedgate assembly is level |
| <input type="checkbox"/> Hydraulic oil level and line connections are tight | <input type="checkbox"/> Encoder installed and secured |
| <input type="checkbox"/> Hydraulic filters are current and gauge is functional | <input type="checkbox"/> Spinner sensor adjusted to proper gap |
| <input type="checkbox"/> Chain oiler tank is full and operates correctly | |

Start engine/Start and run to operational temperatures

- | | |
|---|--|
| <input type="checkbox"/> Hydraulic fittings are tight, no leaks * | <input type="checkbox"/> Conveyor control valve is operating correctly |
| <input type="checkbox"/> Check operation of all alarms | <input type="checkbox"/> Calibrate radar/ground speed input |
| <input type="checkbox"/> Hydraulic flow test: ___GPM @ operating engine RPM | <input type="checkbox"/> Test maximum conveyor(s) RPM |
| <input type="checkbox"/> Check main relief valve setting : ___ PSI | <input type="checkbox"/> Test right and left hand spinner speed; ensure difference is less than 30 RPM (when at operating RPM) |
| <input type="checkbox"/> | |

Stop operation/Turn off engine and engage parking brake

- | | |
|---|--|
| <input type="checkbox"/> Visually check for leaks | <input type="checkbox"/> All oil levels full |
| <input type="checkbox"/> Check belt/chain tension and alignment | |

Perform Calibrations

- Product density testing, crush strength, and SGN scale (See Spread Pattern Calibration section for instructions).
- Catch tests of all products and at least 1 blend for conveyor calibration and document settings and product characteristics
- Spread pattern tests of all products and at least 1 blend and document settings and product characteristics

End of Season

- | | |
|---|---|
| <input type="checkbox"/> Empty unit of all material | <input type="checkbox"/> Clean unit inside and out |
| <input type="checkbox"/> Sand and touch-up paint as necessary | <input type="checkbox"/> Check for leaks |
| <input type="checkbox"/> Wash chain conveyor, lubricate thoroughly when dry | <input type="checkbox"/> Lubricate all grease fittings |
| <input type="checkbox"/> Check spinner discs and fins for wear | <input type="checkbox"/> Ensure all fasteners are secure and properly torqued |
| <input type="checkbox"/> | |

This page is intentionally left blank.

HYDRAULIC SCHEMATICS

The following pages contain representative hydraulic schematics for all configurations of the L3030G4 CNH spreader.

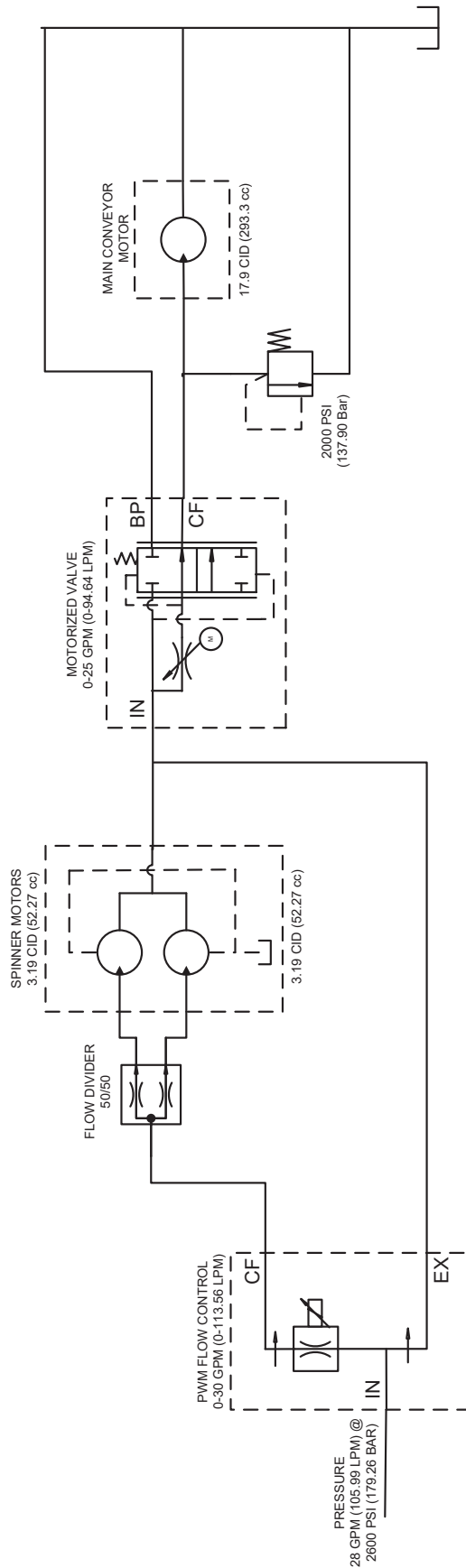

Flow Diagram - Single Bin

L3030G4 CNH

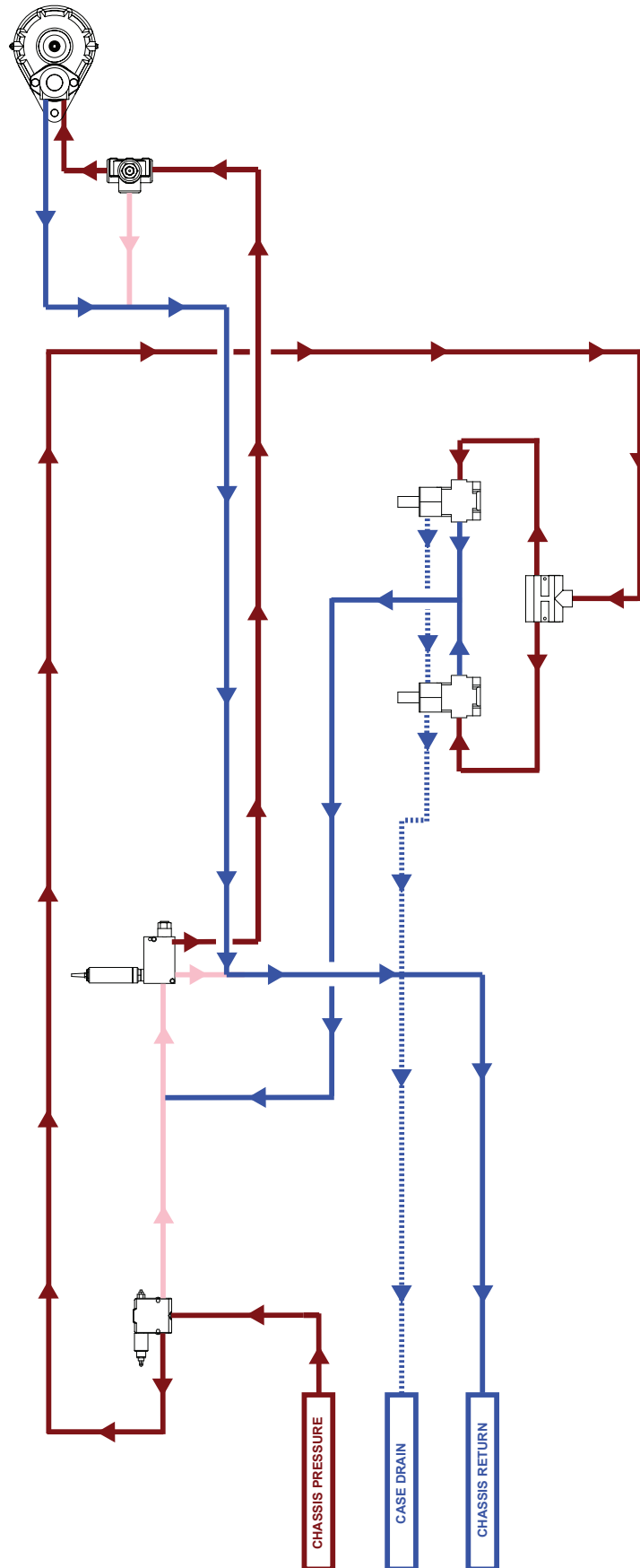

LEGEND

Dark Red Line	CONTROL FLOW	(HIGH PRESSURE)
Light Red Line	EXCESS FLOW	(HIGH PRESSURE)
Blue Line	RETURN FLOW	(LOW PRESSURE)
Dotted Blue Line	CASE DRAIN	(LOW PRESSURE)
Green Line	SUCTION FLOW	(LOW PRESSURE)
Orange Line	PRESSURE ONLY	(HIGH PRESSURE)
Purple Line	BI-DIRECTIONAL FLOW	(HIGH PRESSURE)
Dotted Red Line	LOAD SENSE	(HIGH PRESSURE)

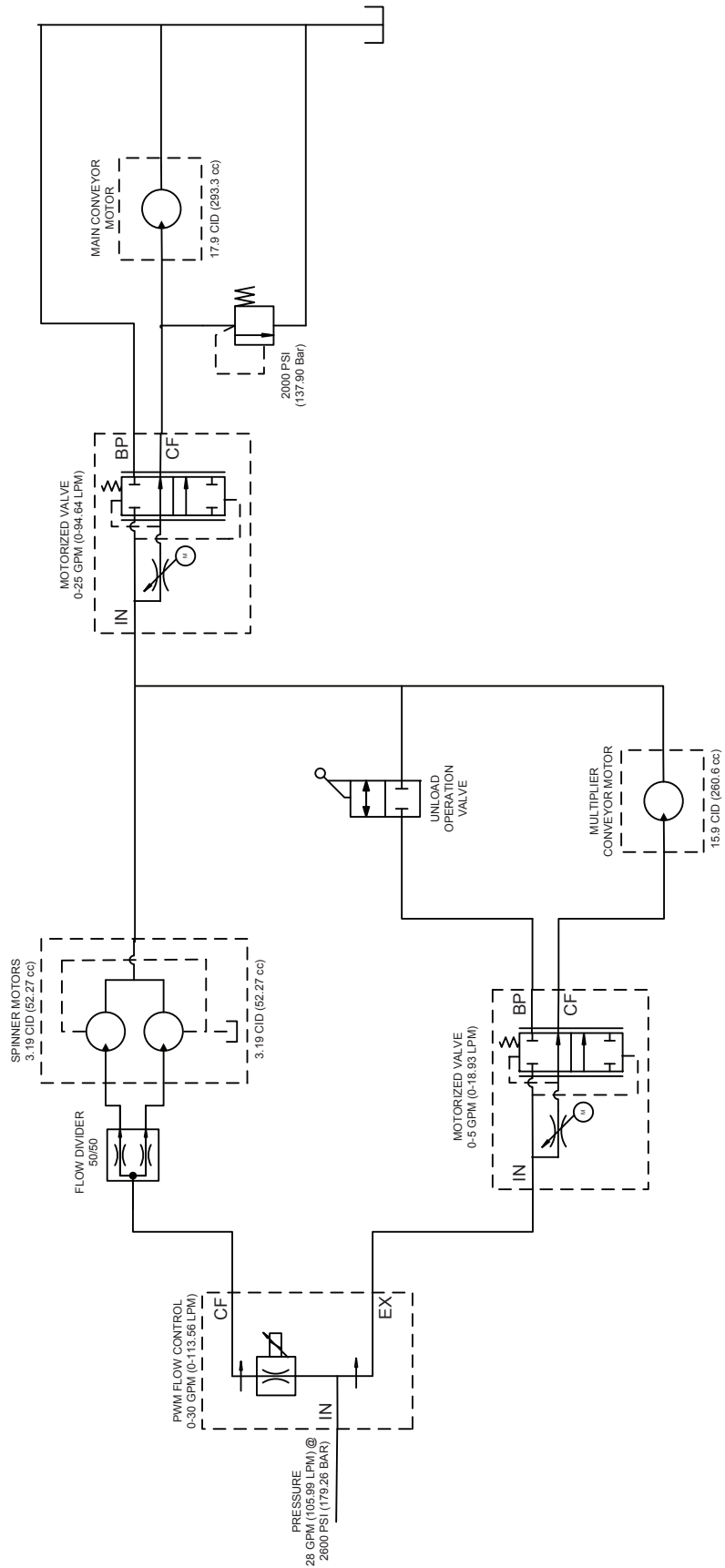

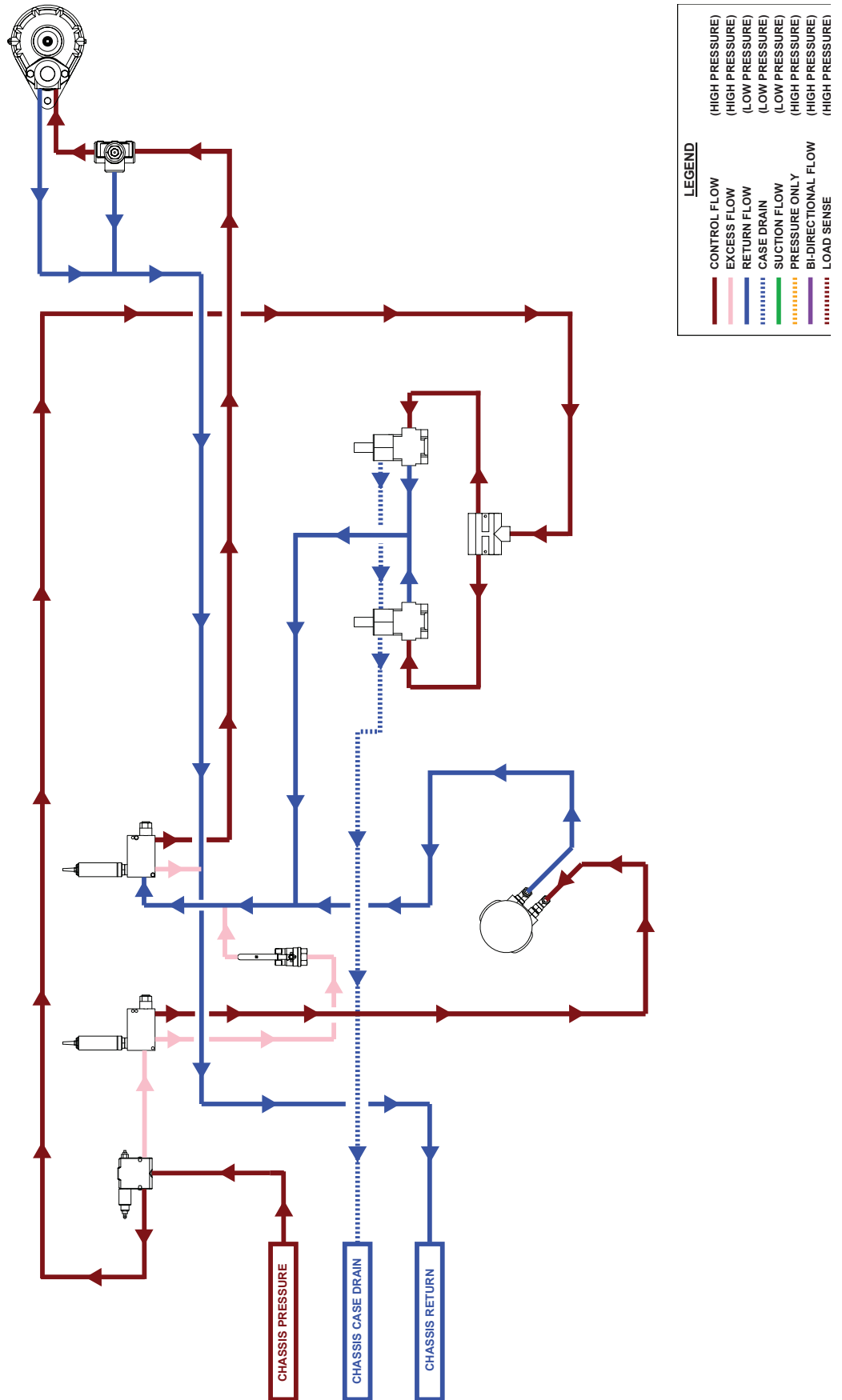

This page is intentionally left blank.

The following information will guide you through using the SGN & Crush Strength Test Kit for your New Leader G4 Spreader. Refer to operator's manual for details on unit safety, operation and maintenance.

PART NUMBER	DESCRIPTION	QUANTITY
308907	Kit - SGN & Crush Strength Test Kit	1
308908	Tester - Crush Strength	1
308909	Scale - SGN	1



WARNING

Use great caution while working around the spreader. Contact with spinners and other moving parts is very dangerous. Do not adjust while machinery is moving, wear eye protection and avoid discharge from spinners. Do not ride on moving spreader.

It is highly recommended to perform a Catch Test, Crush Strength Test and SGN Scale Test prior to each season, before using a new product, or if a significant visible change has occurred with a product. Testing will define granular characteristics and help determine proper spinner settings for optimal product spread.

Conduct a G4 Spread Pattern test to check settings based on test results. Refer to G4 Spreader Installation Instructions and G4 Spread Pattern Manual for installation and adjustment instructions.

Crushing Strength

Crushing strength is the minimum pressure needed to crush individual particles.

Testing and knowing the crushing strength of a particular product will help determine maximum spinner RPM. For example: Any granule with less than three (<3) crush strength should not be broadcast with spinner speeds over 700RPM. Verify granules are not pulverized before increasing spinner speed. Refer to Product Setup Guidelines for additional spinner speed settings with different crush strength.

SGN

SGN (Size Grade Number) is the measurement of granule size in millimeters multiplied by 100. A product's SGN will affect spread width.

Materials with poor uniformity (a significant percentage in 3 or more columns of scale device) may be difficult to spread accurately. Spread Pattern testing should ALWAYS be performed on any new or different material to determine actual spread width.

Catch Test

The CFR number, or cubic feet per revolution number, is a calibration constant entered into the controller to determine rate output from the spreader's conveyor. A catch test is performed to verify accurate rate output per the controller.

NOTE: SGN and Crush Strength together determine spread width.

General Rules:

A small product with low crush strength will have limited spread width capabilities. Spinner RPM must remain lower to keep from pulverizing the soft product, limiting your overall spread width. Additionally, a smaller product has less mass than that of a larger product, and in this case is another limiting factor for overall spread width.

A small product with high crush strength will have limited spread width capabilities. While spinner RPM can be increased with little worry of pulverizing the product, a smaller product has less mass than that of a larger product, which limits how far the product will carry in the spread pattern.

A large product with low crush strength will have limited spread width capabilities. While a larger product with more mass will carry farther, spinner RPM must remain lower to keep from pulverizing the soft product, limiting the overall spread width.

A large product with high crush strength has minimal spread width limitations. Spinner RPM can be increased with little worry of pulverizing the product. Additionally, a large product has more mass than that of a smaller product, allowing the product to carry farther, resulting in a wider spread width.

Product Setup Guidelines

Granule Mesh	Crush Strength	Maximum Spinner RPM	Flotation Machine (Spinner Height 52") Spread Width ft(m)	Post Machine (Spinner Height 72") Spread Width ft(m)
140-200	1	600	60-65(18-20)	70-75(21-23)
	3	650-700	65-70(20-21)	75-80(23-24)
	6	750-800	70-75(21-23)	80-85(24-26)
	8	850-900	75-80(23-24)	85-90(26-27)
220-300	1	600	70-75(21-23)	80-85(24-26)
	3	650-700	75-80(23-24)	85-90(26-27)
	6	750-800	80-85(24-26)	90-95(27-29)
	8	850-900	85-90(26-27)	95-100(29-30)
320-400	1	600	80-85(24-26)	90-95(27-29)
	3	650-700	85-90(26-27)	95-100(29-30)
	6	750-800	90-95(27-29)	100-105(30-32)
	8	850-900	95-100(29-30)	105-110(32-33)
>400	1	600	90-95(27-29)	100-105(30-32)
	3	650-700	95-100(29-30)	105-110(32-33)
	6	750-800	100-105(30-32)	110-115(33-35)
	8	850-900	105-110(32-33)	115-120(35-37)

IMPORTANT! Always check crush strength prior to selecting spinner speed. Pan testing should ALWAYS be performed on different material to determine actual spread width. Verify granules are not pulverized by looking in the three center bins.



Crush Test

IMPORTANT!

Select granules of the most typical size and uniform shape as determined by SGN scale. Crushing strength can significantly increase with particle size.



Figure 1

1. Figure 1 - Place individual granule on solid, smooth surface.
2. Place New Leader crush strength tester over granule, open end flush with surface.
Ensure marker is next to handle.



Figure 2

3. Figure 2 - With one hand on handle, press tester down until granule breaks.



Figure 3

4. Figure 3 - Release handle and note where marker rests on number scale. This is granule crushing strength.
For example, the marker in Figure 3 is between 3 and 4 on the scale. Thus, crushing strength is 3.5.
5. Repeat 10 times and average the values.

SGN Scale Test

The SGN scale is an instrument designed for simple screen test of fertilizer samples. A small box fitted with five sieves, it directly produces a size histogram of the test sample. From this, the SGN can be estimated.

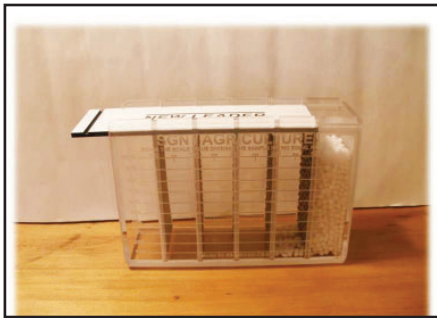

Figure 4

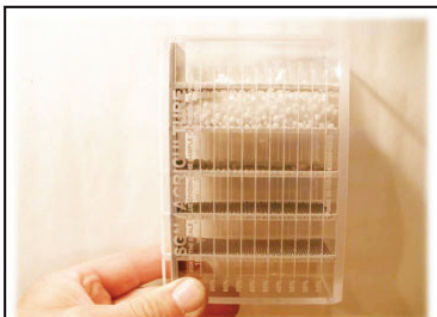

Figure 5

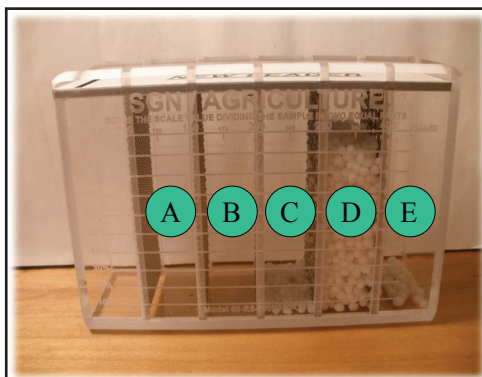

Figure 6

1. Figure 4 - To determine SGN, place scale on flat surface and open lid.
2. Fill end column with selected product to fill line.
- 3.
4. Close lid securely.
5. Figure 5 - Rotate scale vertical and shake to separate material, usually less than two minutes.
6. When material finishes dispersing, turn scale to starting position.
7. Figure 6 - View level of material in each compartment and determine SGN level based on markings.

SGN
Size Grade Number

View each column for percentage

- Column A (120) = 0 material
- Column B (170) = 0 material
- Column C (240) = 5% of 240 equals 12
- Column D (340) = 90% of 340 equals 306
- Column E (400>) = 5% of 400 equals 20
- Total: 12+306+20 = 338 as average SGN

8. Figure 7 - Based on column headings and percent in each field, calculate overall SGN of the sample.

Figure 7

Using the above crush strength example of 3.5 and average SGN size of 338, we can now use the chart to determine our maximum spread width. In this case a maximum spinner speed of 650-700 RPM will produce a spread width of 85' to 100' depending on spinner height.

Granule Mesh	Crush Strength	Maximum Spinner RPM	Flotation Machine (Spinner Height 52") Spread Width ft(m)	Post Machine (Spinner Height 72") Spread Width ft(m)
320-400	1	600	80-85(24-26)	90-95(27-29)
	3	650-700	85-90(26-27)	95-100(29-30)
	6	750-800	90-95(27-29)	100-105(30-32)
	8	850-900	95-100(29-30)	105-110(32-33)

Catch Test

The CFR number, or cubic feet per revolution number, is a calibration constant entered into the controller to determine rate output from the spreader's conveyor. A catch test is performed to verify accurate rate output per the controller.

NOTICE! The following procedure is a guide. Refer to Controller Operations section of manual for details.

NOTE: An optional calibration chute (P/N 312688) is available to simplify the catch test process. The calibration chute fits all New Leader spreader models with 30" wide conveyor bottoms. Contact your local New Leader dealer for details.



WARNING

To prevent injury, disable the spinners by unplugging the PWM valve before beginning the catch test procedure.

1. Disable the spinners by unplugging the PWM valve.
2. Move the spinner assembly to the 4" (10.2cm) position on the indicator by cranking the handle.
3. Remove the Material Divider back plate, and if available, install calibration chute.
4. Position an end loader or other suitable device beneath the spinners to catch material.
5. Load material into all applicable bins.
6. Prime the conveyor as specified per the controller.
 - If using a calibration chute, run the conveyor just until material reaches the end. Remove any excess material that falls into the catching device.
 - If not using a calibration chute, run the conveyor until the spinner discs are full of material. Remove any excess product from the catching device. Do not remove material from spinner discs.
7. Measure the depth of material on the end of the conveyor to verify the constant number feedgate height information entered into the controller. Adjust feedgate height as necessary.
8. Verify that all other product settings entered into the controller are correct.
9. Select the correct channel/node in the controller for the first bin to be tested. Enter the anticipated weight of product to be dispensed from the conveyor.
10. Start the engine and engage hydraulics. Allow to run for several minutes to bring hydraulic oil up to operating temperature. Bring engine up to operating RPM.
11. Following the setup wizard on the controller, run the catch test. The conveyor will start dispensing material, and automatically shut off when the estimated amount of product is dispensed.
12. If not using a calibration chute, leave the material on the spinner discs. Weigh the amount of product that the conveyor actually dispensed into the catching device, and note the result.
13. Enter the actual weight of material dispensed into the controller. The controller will then automatically perform the calibration.
14. Repeat Steps 5 - 12 for all other applicable bins, if an insert bin is installed.
15. Once satisfactory results have been achieved for all applicable bins, turn the engine off, replace the back plate on the Material Divider, return the spinner assembly to its original position setting, and plug the PWM valve back in.

NOTE: For more information on controller operations and setup, contact your local dealer.



WARNING

Use great caution while working around the spreader. Contact with spinners and other moving parts is very dangerous. Do not adjust while machinery is moving, wear eye protection and avoid discharge from spinners. Do not ride on moving spreader.

NOTICE!

Spinner assembly and material divider have NOT been adjusted at the factory. Before spreading material, spread pattern tests must be conducted to properly adjust the spread pattern. A spread pattern test kit is available for this purpose.
 THE MANUFACTURER OF THIS SPREADER WILL NOT BE HELD LIABLE FOR MISAPPLIED MATERIAL DUE TO AN IMPROPERLY ADJUSTED SPREADER.

It is recommended that spread pattern tests be conducted prior to each spreading season, after any spreader maintenance, before applying a new product, and periodically during the spreading season. Spread pattern tests must be performed for each product, blend and application rate.

Spread pattern is affected by many factors. Among the more significant of these are:

- Spinner speed
- Point of material delivery on spinner discs
- Angle of the distributor fins on the spinner discs
- Condition of spinner fins
- Material granule size
- Height of spinners from ground
- Spacing of swaths (driving centers)
- Wind and humidity
- Rate of material delivery

Since many of these factors will vary for each job, trial and experience must be used to determine the adjustments required to obtain the swath width and spread pattern desired. The following instructions outline the adjustments available and the effect that each will have on the spread pattern.

Spread Pattern Test Kit

Spread Pattern Test Kit, part no. 313960, includes the following:

DESCRIPTION	QTY	DESCRIPTION	QTY
Box - Plastic Storage	1	Scale – Density	1
Center Collection Tray - Blue	1	Data Sheet – 100 Ct. Booklet	1
Collection Tray - Brown	22	Funnel	1
Divider Screen	23	Flag	5
Assy – Test Tube Rack	1	Rope – 120' marked	1
Test Tube	23	Stake	2

Spinners

NOTICE!

Spinner discs and fins must be kept clean and polished. Even a small build-up on a spinner fin can significantly affect the spread pattern. Rusty, rough, bent or worn fins will produce poor spread patterns.

In general, critical spinner speed will fall somewhere between 600 and 900 RPM. Spinner speed is adjusted by changing the settings in the controller. Proper spinner speed adjustment is critical in obtaining optimal spread patterns. The best spinner speed to use will depend entirely on the material being spread, and must be determined by testing.

A major factor of maximum pattern width is particle size. Swath width may vary anywhere from 25 feet (7.6 m) for very finely ground dry lime up to 120 feet (37 m) or more for extremely large fertilizer pellets.

For every material there is a critical spinner speed. In other words, there is a speed which will result in the maximum obtainable spread width. Going beyond this speed will not increase spread width, but will degrade, or crush material.

Too high of a spinner speed could result in a heavy deposit behind the truck due to break-down of material. This upper speed limit will be quite low for finely powdered material, and can be quite high for extremely coarse materials.

Spreader Preparation

The spreader to be tested must be in good mechanical condition and properly adjusted. Refer to operator's manual for details.

All damaged and worn parts must be replaced. Spinner discs and fins must be free of any material build-up, rust or paint.

Fill the hopper with the material to be spread. Run the material out to the end of the conveyor.

Set the feedgate and the in-cab controller to deliver the required rate per acre. Make sure the feedgate is level and the indicator reflects the actual gate opening measured by standing a tape measure vertically in the material.

NOTE: Do not match slope of endgate when making this measurement. Measurement must be perpendicular to conveyor.

Adjust the spinner assembly by turning the crank or, if an actuator is installed, change the setting in the controller. To begin testing, position the spinner according to the chart below.

NOTE: This chart is to be used as a reference only to begin testing.

MATERIAL	SPINNER FRAME SETTING in (cm)	SPINNER RPM
Lime	1 (2.5)	625
Straight Urea	3.5 (9.5)	700
All other Fertilizer types and blends, including Urea blends	3.5 (9.5)	750

Test Procedure

Using the data sheets supplied with the kit, document all spreader information and adjustments as necessary. See Figure 8.



SPREAD PATTERN DATA SHEET
New Leader Manufacturing

1330 76th Ave SW
 Cedar Rapids, IA 52404-7052
 (319) 363-8281

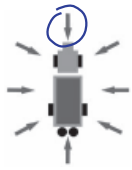
Pattern Test No. <u>1</u> Rev.	Spreader Model: <u>L4000G4</u>	 (Circle Direction of Wind Relative to Spreader)
Site: <u>HECO</u>	Serial No. <u>432165</u>	
Date: <u>10/07/2016</u> Time: <u>10am</u>	Conveyor Type: <u>#4 BOC</u>	
Material Name: <u>MAP</u>	Fan Frame Setting: <u>3.25</u> in.	
Density: <u>65</u> lb/ft ³	Feedgate Height: <u>3</u> in.	
Crush Strength: <u>6</u>	Fin Position: <u>1-2-1-2</u>	
SGN: <u>324</u>		
Application Rate: <u>320</u> lbs/acre	CFR/Constant: <u>.232</u>	Wind: From <u>Straight</u> at <u>5</u> MPH
Spinner Speed: <u>780</u> RPM	Controller Vehicle Speed: <u>12</u> MPH	Relative Humidity: <u>41%</u> %
		Temperature: <u>67</u> °F
		Controller Swath Width: <u>90</u> ft.



Figure 8

Select an area for testing measuring at least 120 feet x 200 feet (37 m x 61 m), and with a slope of less than two degrees.

All testing should be done when the wind velocity is less than 5 MPH (8.05 km). If wind is present, testing must be done with spreader traveling parallel (within ± 15 degrees) to the wind direction.

Do not allow loaded spreader to sit for more than one hour prior to testing.

At this stage of testing, drive the spreader over the collection trays in ONLY ONE DIRECTION.

Insert a plastic grid into each of the 23 collection trays. Position the blue collection tray in the center of the spreader's path with the longest dimension of the tray parallel to the direction of travel. Position the first left-hand and right-hand trays 10' (3m) from center, and all subsequent trays on 5' (1.5m) centers.

Four-Wheeled Vehicles

For four-wheeled application vehicles, position the spreader at the beginning of the course so that the vehicle will straddle the center collection tray. See Figure 9.

Engage spinners before navigating the course. As the vehicle approaches the flag positioned 75' before the row of collection trays, engage the conveyor(s). Do not shut the conveyor(s) off until the vehicle approaches the second flag.

Drive spreader completely through course at normal operating speeds.

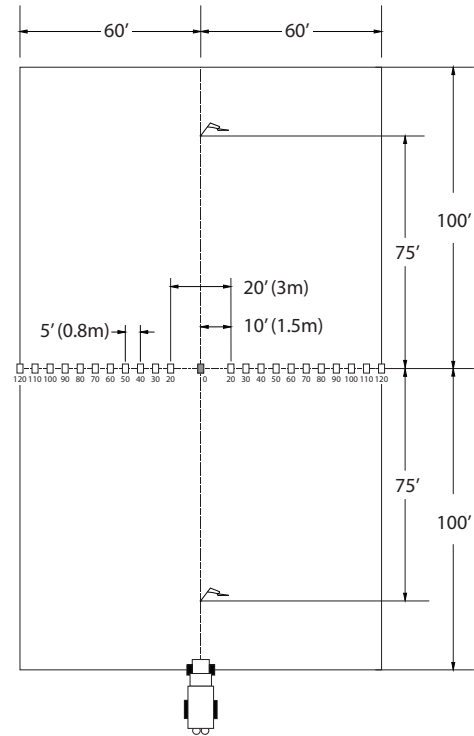

Figure 9 – Four-Wheeled Vehicles

Three-Wheeled Vehicles

For three-wheeled application vehicles, straddling the center tray is not possible. Place the center collection tray beneath the vehicle just behind the front tire when the spreader is in position at the beginning of the course. See Figure 10.

Engage both the spinners and conveyor(s) before navigating the course. Do not shut the conveyor(s) off until the vehicle approaches the second flag.

Drive spreader completely through course at normal operating speeds.

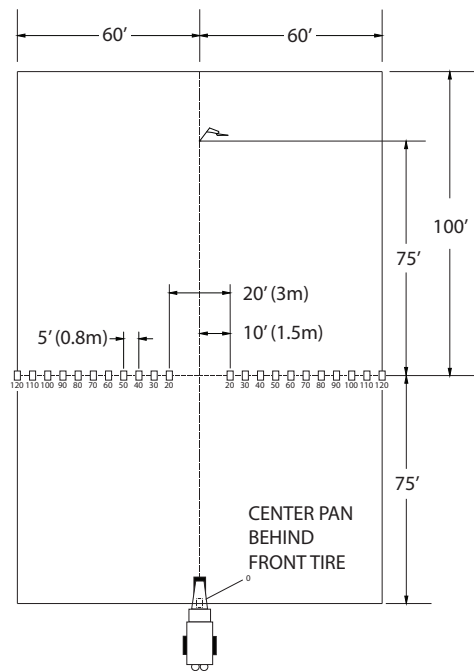

Figure 10 – Three-Wheeled Vehicles

Test Results

After navigating the course, shut the spreader down and park in a secure location.

Using the funnel, transfer the contents of each collection tray into its corresponding test tube beginning at one end of the trays and working towards the opposite end.

If spreading a blend of materials, inspect all tubes to determine if the blend is consistent across the entire swath width. If the blend is not consistent, use a narrower swath width. The swath width should be based on the material thrown the shortest distance.

NOTE: If spreading a slow release nitrogen product, inspect the three center tubes for crushed material. If crushed material is excessive, reduce spinner speed by 25 RPM and repeat test. If little to no crushed material is present, spinner speed may be increased by 50 RPM to increase overall swath width if desired. As long as there is little to no crushed material, this process can be repeated until maximum swath width is achieved.

Record each test tube's volume in the box on the data sheet under the corresponding tray position and graph the spread pattern profile. See Figure 11.

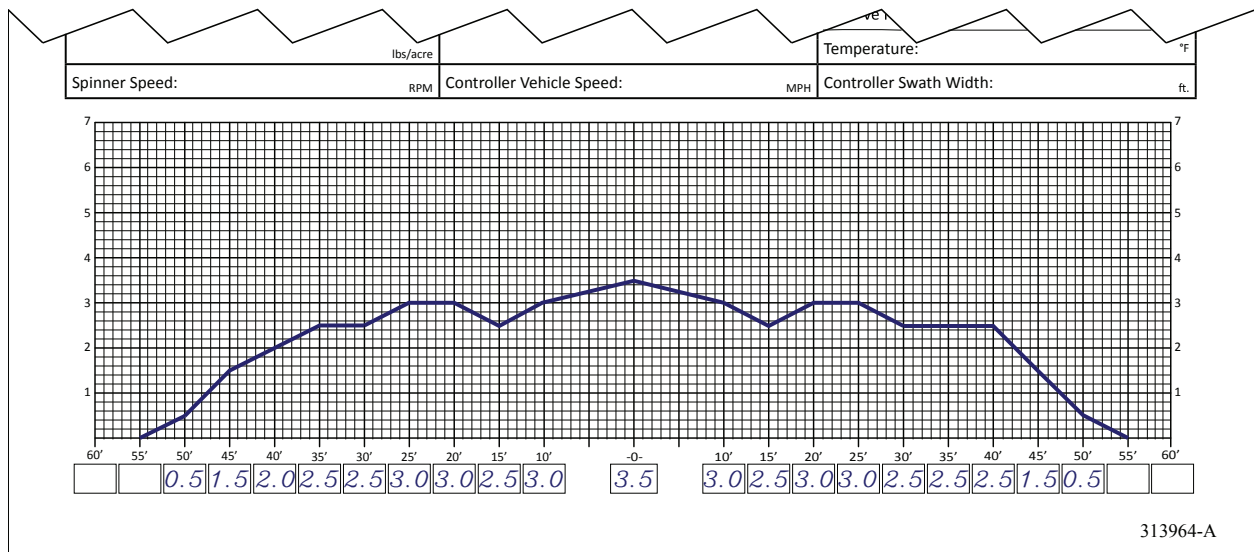

Figure 11

Looking at the material in the test tubes and the graphed profile on the data sheet, compare the overall shape of the spread pattern to the three acceptable patterns, shown in Figure 5. If an acceptable pattern has not been achieved, proceed to "Troubleshooting" on page <DT>. Once an acceptable pattern has been achieved, proceed to "Determining Driving Centers" on page <?>.

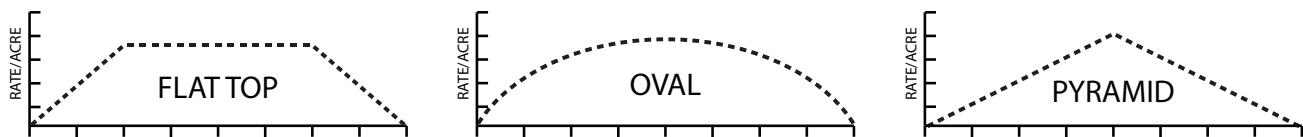

Figure 12 – Acceptable Patterns

Determining Driving Centers

Once an acceptable pattern is obtained, as shown in Figure 12, driving centers can be determined. To determine optimum driving centers (effective swath width), determine the average amount of material in the center of the pattern. Figure 13 shows an example data sheet recorded from the profile shown in Figure 14. Based on the example, the average amount of material in the center of the pattern is 3.0, as indicated with the red dotted line.

Next, locate the points on both the left and right side of the pattern where the amount of material is half the average amount at the center of the pattern. In the example shown in Figure 13, these points are located 45' to the left of center, and 45' to the right of center. The distance between these two points (90') represents the driving centers to use.

NOTE: Once the effective swath width has been established, a change in the controller may be required.

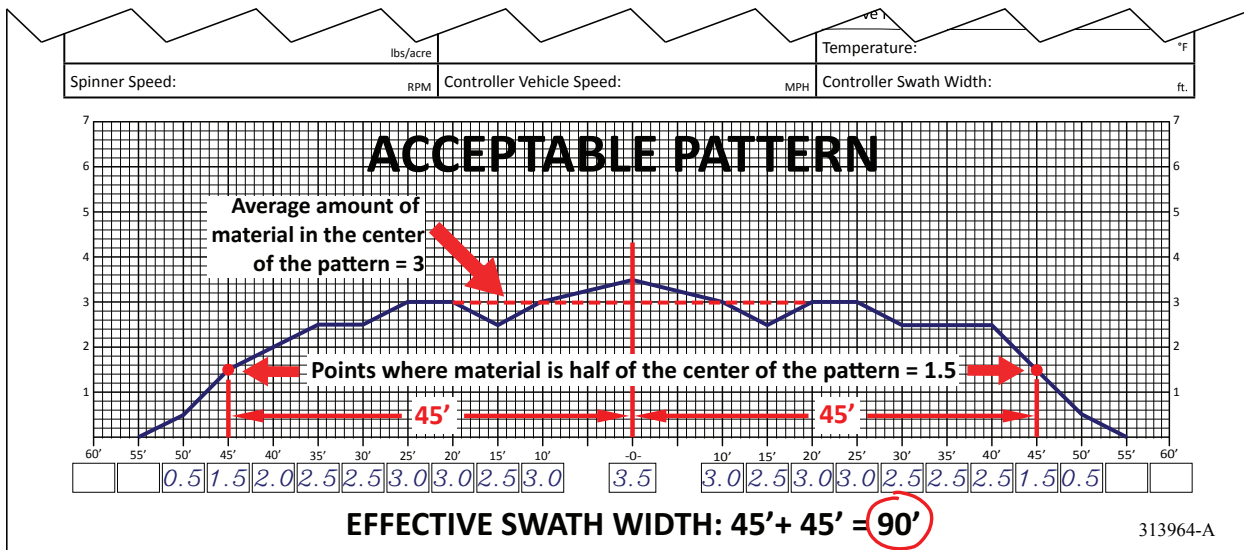

Figure 13 - Effective Swath Width

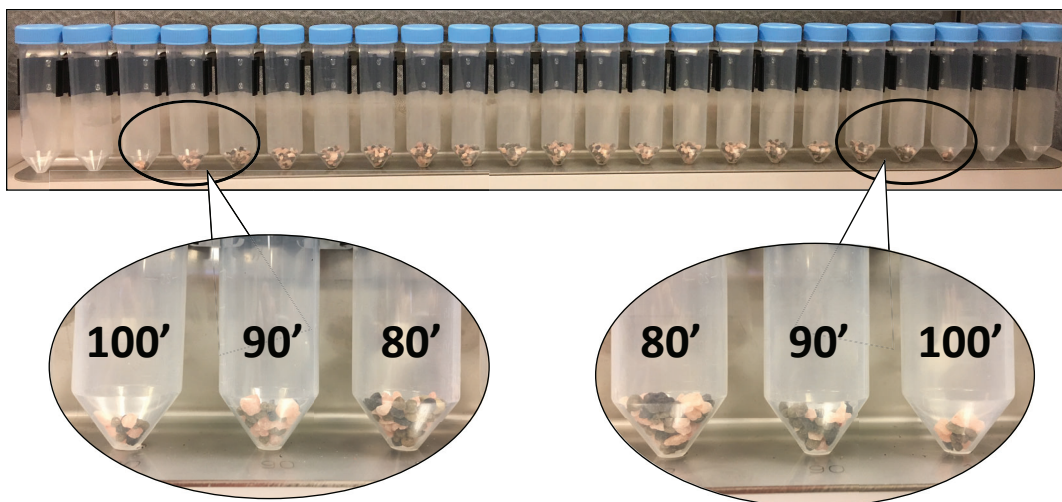

Figure 14

Troubleshooting

NOTE: It is highly recommended that ONLY ONE ADJUSTMENT be made between test samples taken. If more than one adjustment is made, it will be difficult to determine which adjustment was responsible for the change in pattern shape.

Problem	Pattern	Recommended Adjustments
Heavy Directly Behind the Vehicle		1. Move the spinner forward (toward the conveyor).
Light Directly Behind the Vehicle		1. Move the spinner rearward (away from conveyor).
Light Outside Vehicle's Tire Tracks		1. Check spinner fins for material buildup. 2. Increase spinner RPM. 3. Move spinner fins to 2 - 3 - 2 - 3 positions. See Figure below.
Pattern Off Center		1. Check to see feedgate is level and free of caked material. 2. Make sure hillside divider is mounted squarely and centered. 3. Check to be sure spinner assembly is mounted squarely and centered. 4. Make sure material divider is mounted squarely and centered. 5. Testing should be done parallel to wind.

Figure 15

Spinner fins are adjustable to radial angle as shown in Figure 16. Refer back to Figure 6 for fin adjustment recommendations.

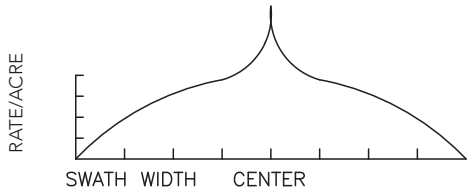
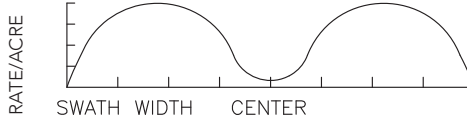
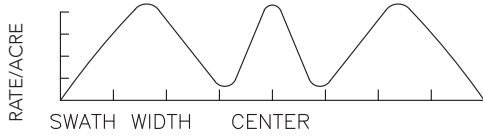
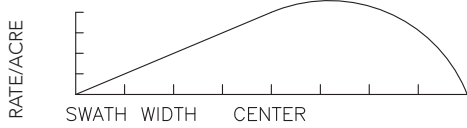
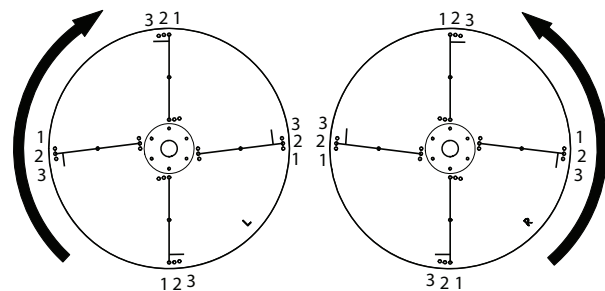

Figure 16 - Spinner Fin Adjustment

Verifying Driving Centers

Once optimum driving centers (effective swath width) have been established, conduct a final "S" pass over the trays to verify. Refer to Figure 17.

1. With both the spinners and conveyor turned off, drive the spreader through the center of the course, establishing an "AB" line. If the spreader vehicle is a three-wheel type, remove the center pan.
2. Line the vehicle up with either end of the row of collection trays, at a distance from the "AB" line equal to the effective swath width.
3. With both the spinner and conveyor engaged, drive past the trays.
4. Switch back and drive over the center of the trays, down the "AB" line.
5. Drive through the row of trays and switch back once again, driving past the trays on the opposite side, at an equal distance from the "AB" line as the first pass.

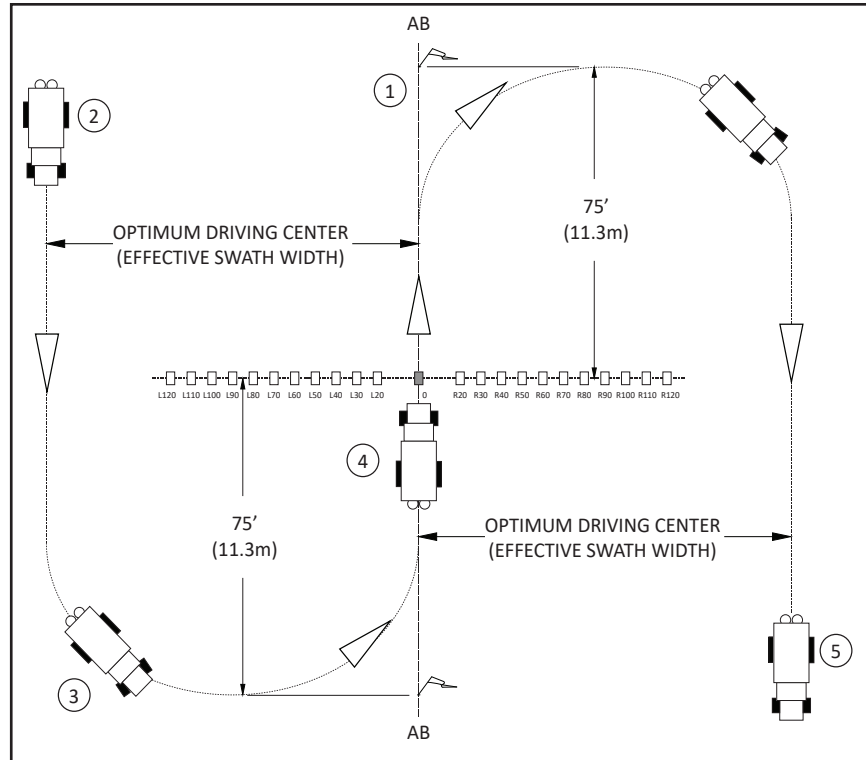

Figure 17

If the driving centers were determined correctly, all trays should have a similar amount of material, showing a near flat profile in the test tubes. If the trays near the center of the row contain more material than the others, increase driving centers. If the trays near the center of the row contain less material, decrease driving centers.

NOTE: If spreading a blend of materials, verify blend of all products is consistent across all tubes.