



**L4000 G4
Operator's Manual**

UNIT SERIAL NO. _____

MULTIAPPLIER/MULTIBIN SERIAL NO. _____

MANUAL NUMBER: 307074-AA-I

EFFECTIVE 02/2019



**1330 76TH AVE SW
CEDAR RAPIDS, IA 52404-7052
PHONE (800) 363-1771 | FAX (319) 286-3350
www.newleader.com**

Copyright 2019 Highway Equipment Company, Inc.
Now doing business as New Leader Manufacturing

Table of Contents

Interactive Features	4
Notes	5
Warranty	6
Preface	7
Safety	8
Important Safety Information	8
Safety Alert Symbols	8
General Safety Rules	9
Safety Decals.....	19
Safety Decal Maintenance.....	19
Safety Decal Installation.....	19
Installation Instructions	25
Hydraulic Requirements.....	25
Truck Requirements.....	25
Lifting the Spreader	26
Installing Body	27
Securing to Frame	28
Fender Installation.....	29
Hydraulic Hose Installation.....	31
Hydraulic Pump Installation.....	31
Hydraulic Hose Installation Guide	32
Filling Hydraulic System.....	33
Hydraulic Drain Lines	33
Electrical Connections	33
Light Installation	33
Insert Installation Instructions.....	34
Hydraulic Requirements.....	34
Spreader Preparation.....	34
Feedgate Adjustment.....	36
Insert Installation	37
Insert Installation Instructions.....	38
Insert Installation Instructions.....	39
Lower Divider - Multibin	40
Hydraulics.....	41
Hydraulic Hose Installation.....	42
Hillside Divider & Conveyor Cover - MultApplier.....	43
Micro Cover Installation.....	44
Electrical Connections	45
Insert Removal/Endgate Installation.....	46
General Description	49
Introduction.....	50
Initial Startup.....	60
G4 Spinner Squaring.....	61
Field Testing.....	65
General Operating Procedures	66

Lubrication & Maintenance.....	67
Preventative Maintenance Pays!	67
Hydraulic System	67
Service Schedule	67
Conveyor Gearcase	68
Hydraulic Hose	68
Conveyor Chain	69
#4 BOC Conveyor Belt Maintenance.....	70
Bin Sensor	71
Lubrication of Bearings.....	71
Fasteners	71
Clean-Up	71
Spinner Fins	72
Spinner Deflectors.....	72
Material & Hillside Flow Dividers	72
Lubricant & Hydraulic Oil Specifications	73
Hydraulic System	73
Gearcase Lubricant	73
Grease Gun Lubricant.....	73
Lubrication & Maintenance Chart	74
Chain Conveyors	74
Troubleshooting	76
MultiBin Cover Air Schematic	78
Standard Torques.....	79
Pre- and Post-Season Check Lists	80
Hydraulics.....	81
MultiApplier Ready Hydraulic Schematic	82
MultiApplier Ready Hydraulic Flow Diagram.....	83
Hi Performance MultiApplier Ready Hydraulic Schematic.....	84
Hi Performance MultiApplier Ready Hydraulic Flow Diagram	85
MultiApplier Complete Hydraulic Schematic	86
MultiApplier Complete Hydraulic Flow Diagram	87
Hi Performance MultiApplier Complete Hydraulic Schematic.....	88
Hi Performance MultiApplier Complete Hydraulic Flow Diagram.....	89
MultiBin Complete Hydraulic Schematic.....	90
MultiBin Complete Hydraulic Flow Diagram.....	91
Spread Pattern.....	93
Catch Test	93
Spread Pattern	94
Spread Pattern Test Kit	94
Spinners.....	95
Spreader Preparation	95
Test Procedure	97
Test Results	99
Troubleshooting	100
Determining Driving Centers	101
Verifying Driving Centers	102

NOTE:

This manual incorporates several interactive features to provide supplemental information and ease of navigation. The information below is to aid in the identification and use of these features.

Hyperlinks

Hyperlinks provide direct access to a specific destination when clicked. The entire Table of Contents of this manual is hyperlinked to provide quick access to all sections of this manual when viewing the electronic version.

Hyperlinks within the content are denoted by **blue, bold underlined text**. Electronic format viewers can click these links for direct access to New Leader online features. Internet access is required.

Insert Current New Leader Warranty

PLEASE ! ALWAYS THINK SAFETY FIRST !!

The purpose of this manual is to familiarize the person (or persons) using this unit with the information necessary to properly install, operate, and maintain this system. The safety instructions indicated by the safety alert symbol in the following pages supersede the general safety rules. These instructions cannot replace the following: the fundamental knowledge that must be possessed by the installer or operator, the knowledge of a qualified person, or the clear thinking necessary to install and operate this equipment. Since the life of any machine depends largely upon the care it is given, we require that this manual be read thoroughly and referred to frequently. If for any reason you do not understand the instructions, please call your authorized dealer or our Product Sales and Support Department at 1-888-363-8006.

It has been our experience that by following these installation instructions, and by observing the operation of the spreader, you will have sufficient understanding of the machine enabling you to troubleshoot and correct all normal problems that you may encounter. Again, we urge you to call your authorized dealer or our Product Sales and Support Department if you find the unit is not operating properly, or if you are having trouble with repairs, installation, or removal of this unit.

We urge you to protect your investment by using genuine NLM parts and our authorized dealers for all work other than routine care and adjustments.

New Leader Manufacturing reserves the right to make alterations or modifications to this equipment at any time. The manufacturer shall not be obligated to make such changes to machines already in the field.

This Safety Section should be read thoroughly and referred to frequently.

ACCIDENTS HURT !!!

ACCIDENTS COST !!!

ACCIDENTS CAN BE AVOIDED !!!

Important Safety Information

Figure 1.1 - The need for safety cannot be stressed strongly enough in this manual. At New Leader Manufacturing, we urge you to make safety your top priority when operating any equipment. We firmly advise that anyone allowed to operate this machine carefully read, learn and understand all messages and information in this manual and on machine's safety decals before operating machine, as well as familiarize themselves with the location and function of all machine controls.

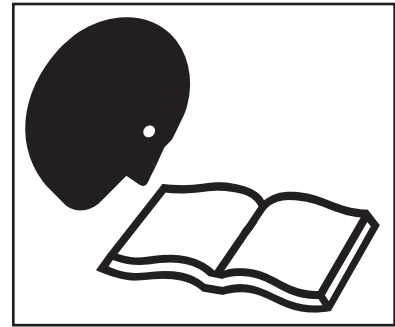



Figure 1.1

The following guidelines are intended to cover general usage and to assist you in avoiding accidents. There will be times when you will run into situations that are not covered in this section. At those times the best standard to use is common sense. If, at any time, you have a question concerning these guidelines, please call your authorized dealer or our Product Sales & Support Department at (800) 363-1771.

Safety Alert Symbols

	<p>TAKE NOTE! THIS SAFETY ALERT SYMBOL FOUND THROUGHOUT THIS MANUAL IS USED TO CALL YOUR ATTENTION TO INSTRUCTIONS INVOLVING YOUR PERSONAL SAFETY AND THAT OF OTHERS. FAILURE TO FOLLOW THESE INSTRUCTIONS CAN RESULT IN INJURY OR DEATH.</p>
---	---

In this manual and on the safety signs placed on the unit, the words "DANGER," "WARNING," "CAUTION," and "NOTICE" are used to indicate the following:

	<p>DANGER</p>
---	----------------------

Indicates an imminently hazardous situation that, if not avoided, WILL result in death or serious injury. This signal word is to be limited to the most extreme situations and typically for machine components that, for functional purposes, cannot be guarded.

	<p>WARNING</p>
---	-----------------------

Indicates a potentially hazardous situation that, if not avoided, COULD result in death or serious injury, and includes hazards that are exposed when guards are removed. It may also be used to alert against unsafe practices.

	<p>CAUTION</p>
---	-----------------------

Indicates a potentially hazardous situation that, if not avoided, MAY result in minor or moderate injury. It may also be used to alert against unsafe practices.

<p>NOTICE!</p>

Is used for informational purposes in areas which may involve damage or deterioration to equipment but generally would not involve the potential for personal injury.

NOTE: Provides additional information to simplify a procedure or clarify a process.

Operations

PREPARE FOR EMERGENCIES

Figure 1.2 - Be prepared if a fire starts. Keep a fully charged fire extinguisher and first aid kit in accessible place on the vehicle at all times.

Fire extinguisher must be Type ABC or Type BC.

Keep emergency numbers for doctors, ambulance service, hospital and fire department available at all times.



Figure 1.2

INSPECT HARDWARE BEFORE USE

Figure 1.3 - Inspect all bolts, screws, fasteners, keys, chain drives, body mounts and other attachments periodically. Immediately replace any missing or damaged parts immediately with proper specification parts.

Inspect spinner fins, spinner frame mounting and spinner fin hardware daily. Look for missing or loose fasteners, wear and cracks. Replace immediately if needed. Use only new SAE grade 5 or grade 8 screws and self-locking nuts.

Tighten all bolts, nuts and screws to specified torques. Refer to "Standard Torques" in Maintenance section of this manual.

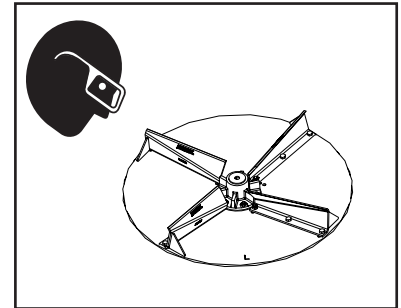

Figure 1.3

HANDLE FLAMMABLE MATERIALS SAFELY

Figure 1.4 - Handle fuel and hydraulic oil with care. They are highly flammable.

Always stop the engine before refueling machine or filling hydraulic reservoir.

Never smoke while adding fuel or oil to machine. Add fluids in a safe place away from open flame and sparks.

Do not allow overflow. Clean up spilled fuel and oil immediately.

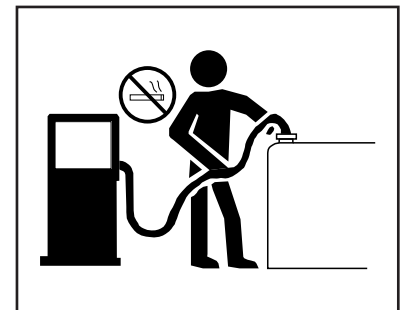

Figure 1.4

Always have a multipurpose dry chemical fire extinguisher filled and available during machine operation and when adding fuel. Know how to use it.

General Safety Rules

Operations

HANDLE HAZARDOUS MATERIALS SAFELY

Figure 1.5 - Materials to spread can be dangerous.

Improper selection, application, use or handling may be a hazard to persons, animals, plants, crops or other property.

A Safety Data Sheet (SDS) provides specific details on chemical products: physical and health hazards, safety procedures and emergency response techniques.

Check the SDS before starting any job using a hazardous material. Follow all instructions and precautions given by the material manufacturer.



Figure 1.5

WORK IN WELL-VENTILATED AREAS



WARNING

Never run machine engine inside a building unless adequate ventilation is provided to safely and properly remove exhaust fumes.

Figure 1.6 - Always work in a properly ventilated area.

Engine exhaust fumes can cause sickness or death. If it is necessary to run an engine in an enclosed area, use proper equipment to safely remove exhaust fumes from the working area.

Open building doors and get fresh air into the working area whenever possible.



Figure 1.6

PROTECT AGAINST NOISE

Figure 1.7 - Long periods of exposure to high decibels or loud noise can cause hearing impairment or loss.

Wear proper hearing protection during periods of exposure to high decibels or loud noise.

Wear a proper hearing protective device such as earmuffs or earplugs to protect against high decibels and / or uncomfortable loud noises.

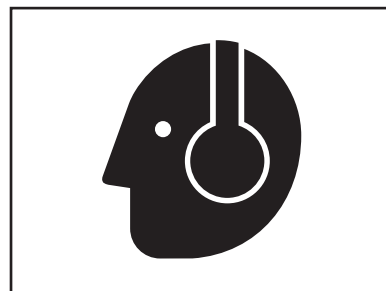

Figure 1.7

Operations

AVOID MOVING PART HAZARDS

Figure 1.8 - Entanglement in rotating drive lines or moving parts will cause serious injury or death.

Stay clear of all moving parts, such as shafts, couplings and universal joints.

Make sure all personnel are clear of machine before starting.



Figure 1.8

Figure 1.9 - Do not operate machine without all guards and shields closed and secured. Disconnect and lock out power source before removing guards.

Disconnect and lock out power source before adjusting or servicing.

Keep hands, feet, hair and clothing away from moving parts.

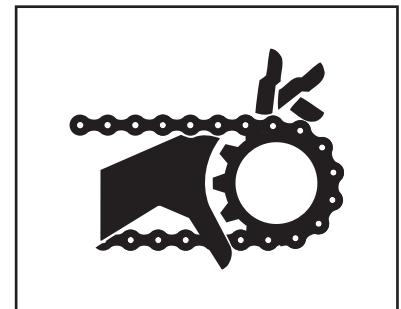

Figure 1.9

Figure 1.10 - Keep away from spinners while they are turning.

Rocks, scrap metal and other material can be thrown from the spinners violently. Stay away from discharge area.

Stop machine before servicing or adjusting. Wear eye protection.

Make sure discharge area is clear before spreading.

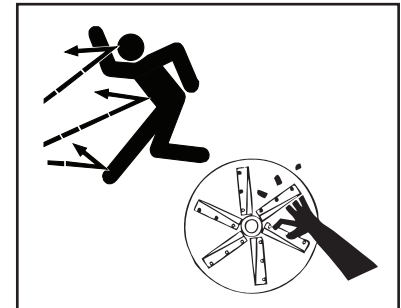

Figure 1.10

Figure 1.11 - Stay out of the spreader.

If it is necessary to enter the spreader, return to the shop, empty body, turn off all power, engage brakes, shut down engine and remove keys before entering.

Tag all controls to prohibit operation. Tags should only be placed, and later removed, by the person working in the body.

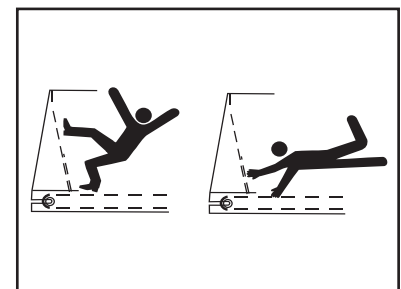

Figure 1.11

Operations

DO NOT CLIMB OR STAND ON MACHINE

Figure 1.12 - Never allow any personnel to ride in or on the machine.

Use only inspection ladder or portable ladder to view the unit. Use caution when getting on and off the ladder, especially in wet, icy, snowy or muddy conditions. Clean mud, snow and ice from steps and footwear.

Always maintain three-point contact with steps, ladders and handholds. Face the machine when mounting and dismounting inspection ladder. Do not jump off the machine.



Figure 1.12

OPERATE MACHINE SAFELY

Always walk around and visually inspect the machine before using. Check immediate vicinity of machine for people and obstructions. Ensure adequate visibility.

Avoid distractions such as reading, eating or operating personal electronics that take your attention away from operating the machine. Never operate the machine under the influence of alcohol, drugs or while otherwise impaired.

Always come to a complete stop before reversing. Be sure that all personnel are clear of machine path. Turn around and look directly for best visibility. Ensure all rear view mirrors are properly installed and adjusted. Use a signal person when backing if view is obstructed or when in close quarters.

Always disengage hydraulics before shutting down engine. DO NOT start engine with hydraulics engaged.

General Safety Rules

Transportation & Handling

TRAVELING & TRANSPORTING ON PUBLIC ROADS

Always walk around and visually inspect the machine before traveling on public roads. Check for damage and/or faulty components that can fail and create a hazard or unsafe condition. Make sure all machine systems operate properly, including but not limited to: headlights, tail and brake lights, hazard warning lights, turn indicators, parking brake, horn and rear view mirrors. Repair or replace any component that is not in proper working order.

Never drive machine at a speed that causes it to bounce or cause loss of control.

Obey all traffic safety laws and regulations. Operate the machine with hazard warning lights on, unless prohibited by law. It is the operator's responsibility to activate and use road lights properly while traveling on public roads.

Cover all loads that may spill or blow away. Environmental damage may result. Do not spread dusty materials where dust may create pollution, visibility issues or interfere with traffic on public roads.

When transporting equipment or machine on a trailer, ensure it is properly secured. Be sure that SMV signs on equipment or machine are covered while in transport on a trailer.

Be aware of overhead structures and power lines. Make sure machine can safely pass under. Refer to "Dimensions & Capacities" pages in the Operations section of this manual.

NAVIGATING ROUGH & UNEVEN TERRAIN

Figure 2.1 - Turn slowly and be careful when traveling on rough surfaces and side slopes. Avoid holes, ditches and obstructions that may cause machine to roll over, especially with a loaded spreader.

Never drive near the edge of a gully or steep embankment.

Load may shift, causing vehicle to tip.

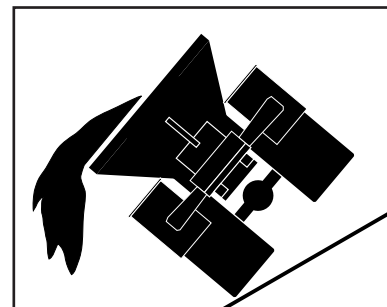

Figure 2.1

Maintenance

READ AND UNDERSTAND MAINTENANCE PROCEDURES

Figure 3.1 - Read the maintenance and safety instructions and understand them before performing any maintenance procedure.

Never perform any maintenance procedure or repair if the instructions and safety procedures are not fully understood. Only trained and qualified personnel should perform any maintenance procedure or repair.

Never modify any equipment or add attachments not approved by New Leader Manufacturing.

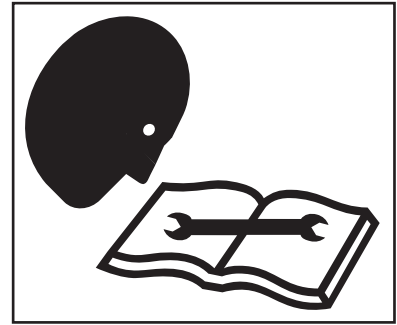

Figure 3.1

DO NOT SERVICE OR ADJUST MACHINE WHILE IN MOTION

Figure 3.2 - Never lubricate, service or adjust the machine or any of its components while they are moving.

Never wear loose clothing or jewelry when working near machine tools or moving parts.

Remove rings and other jewelry to prevent electrical shorts and other personal injury when in contact with machine tools or moving parts.

Close and secure all guards removed for service. Check all screws, bolts, nuts and fasteners for proper torques before operating machine.

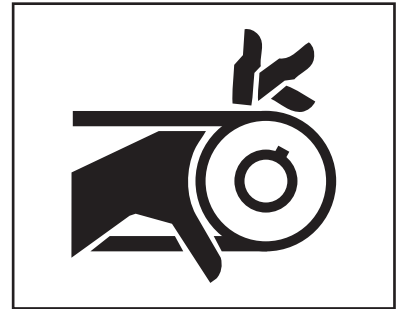

Figure 3.2

WEAR PROPER PROTECTIVE EQUIPMENT

Figure 3.3 - Wear close-fitting clothing and proper safety equipment for the job.

Always wear eye protection when working on or around the machine.

Wear a suitable hearing protection device such as earmuffs or earplugs to protect against high decibels or loud noises.

Prolonged exposure to high decibels or loud noise can cause hearing impairment or loss of hearing.

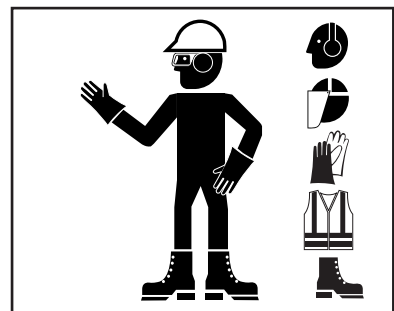

Figure 3.3

Wear protective gloves to protect hands from cuts, abrasions and minor burns.

General Safety Rules

Maintenance

HANDLE FLAMMABLE SOLVENTS SAFELY

Figure 3.4 - Never use diesel fuel, kerosene, gasoline or any flammable solvents for cleaning.

Perform work using flammable fluids and solvents in a safe place away from open flame and sparks. Do not smoke.

Do not weld, grind or flame cut on any tank containing oil, fuel, fumes or any other flammable material, or any container that contents or previous contents are unknown. Move all flammable materials and containers away from work area.

Clean up spilled fuel and oil immediately.

Always have a multipurpose dry chemical fire extinguisher filled and available. Know how to use it.

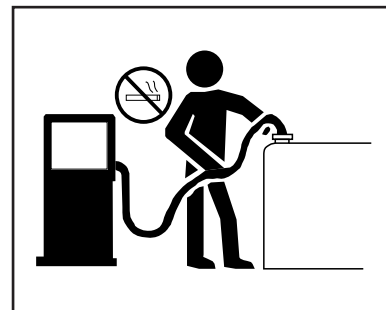

Figure 3.4

USE PROPER LIFTING EQUIPMENT

Figure 3.5 - Use only lifting devices that meet or exceed OSHA standard 1910.184 or ASME B30.20-2013.

Never lift equipment over people.

Never lift a loaded unit. Never lift unit with any loose objects or persons in the body. Loads may shift or fall if improperly supported, causing death, serious injury or machine damage.

Before unfastening heavy parts or assemblies, support with adequate hoist or other device to prevent falling, tipping, swinging or any other movement that may cause injury or damage.



Figure 3.5

USE PROPER TOOLS FOR THE JOB

Figure 3.6 - Use of improper tools (such as a screwdriver instead of a pry bar, pliers instead of a wrench, a wrench instead of a hammer) can cause serious injuries or machine damage.

Use power tools only to loosen threaded parts and fasteners. Using power tools to tighten may cause over-tightening and component damage.

Use only service parts meeting New Leader specifications.

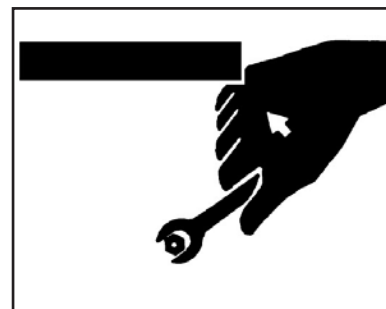

Figure 3.6

General Safety Rules

Maintenance

HIGH PRESSURE FLUID HAZARDS

Figure 3.7 - Escaping fluid under pressure can penetrate the skin causing serious injury.

Always stop machine, allow to cool and relieve pressure before servicing hydraulic system. Never open hydraulic lines under pressure. Make sure all connections are tight and all hoses are in good condition before pressurizing system.

Always use a piece of cardboard or wood to search for leaks instead of hand. Wear impervious gloves and eye protection when servicing system.

Seek medical attention immediately if fluid penetrates your skin. Gangrene may result if wound is left untreated.



Figure 3.7

AVOID HEATING NEAR HIGH PRESSURE FLUID LINES

Figure 3.8 - Flammable spray can be generated by heating near pressurized fluid lines, resulting in burns to yourself and bystanders.

Do not heat by welding, soldering or using a torch near pressurized fluid lines or other flammable materials.

Pressure lines can suddenly burst when heat goes beyond the immediate flame area.

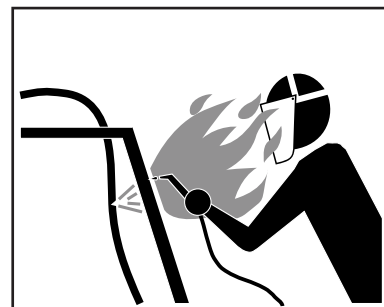

Figure 3.8

AVOID TOXIC FUMES & DUST

Figure 3.9 - Hazardous fumes can be generated when paint is heated from welding, soldering or using a torch.

Remove paint before heating:

- Remove a minimum of 4 in (100mm) from area to be affected by heating. If paint cannot be removed, wear an approved respirator while heating or welding.
- Avoid breathing dust from sanding or grinding on paint.
- If a solvent or paint stripper is used, wash stripper away with soap and water before heating or welding. Remove solvent or paint stripper containers and other flammable material from area. Allow fumes to disperse for at least 15 minutes before heating or welding.

Do not use chlorinated solvents in areas where welding will take place.

Perform all work in a well-ventilated area that will carry all toxic fumes and dust away.



Figure 3.9

General Safety Rules

Maintenance

CLEAN MACHINE OF HAZARDOUS CHEMICALS



CAUTION

During application of hazardous chemicals, residue can build up on the inside or outside of the vehicle. Clean vehicle according to use instructions of hazardous chemical.

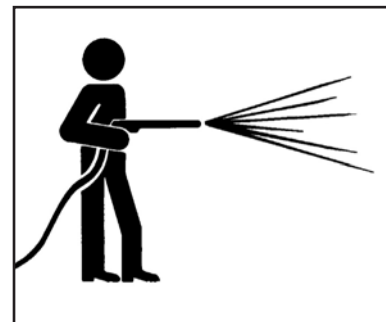

Figure 3.10

Figure 3.10 - When exposed to hazardous chemicals, clean exterior and interior of vehicle daily to keep free of the accumulation of visible dirt and contamination.

1. Clean operator's station to maintain unobstructed visibility of all windows and mirrors, and safe operation of all controls.

NOTICE!

Directing pressurized water at electronic/ electrical components, bearings and hydraulic seals or other sensitive parts and components may cause product malfunctions. Reduce pressure and spray at 45 to 90 degree angles.

2. Wash entire exterior of vehicle.
3. Dispose of any wash water with hazardous concentrations of active or non-active ingredients according to published regulations or directives.

HANDLE BATTERIES SAFELY



WARNING

Sulfuric acid in battery electrolyte is poisonous. It can burn skin, eat holes in clothing, and cause blindness if it contacts eyes.

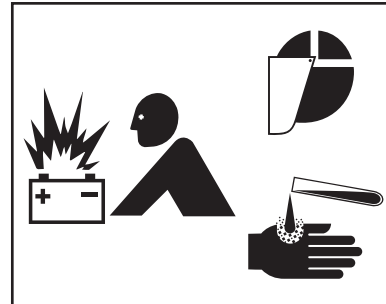

Figure 3.11

Figure 3.11 - Lead acid batteries generate flammable and explosive gases. Keep sparks and flame away from batteries. Do not smoke.

If acid contacts eyes, skin or clothing, flush with water immediately. Seek immediate medical attention if acid contacts eyes.

PROPER TIRE MAINTENANCE

Figure 3.12 - Never weld on a wheel or rim that has a tire on it.

Never attempt to mount or remove a tire unless using the proper equipment, tire safety cage, instructions, training, and you are qualified to perform the work safely. Failure to follow the correct procedures when mounting a tire on a wheel or rim can cause an explosion and serious injury.

Tire service procedures must be performed by trained and qualified personnel.

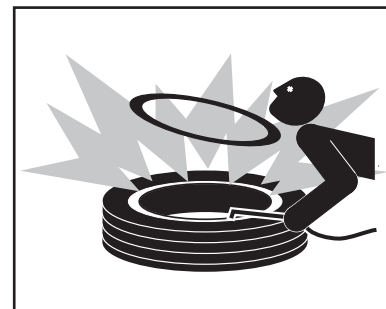

Figure 3.12

Storage

PARK VEHICLE SAFELY

Figure 4.1 - When leaving the vehicle unattended for any reason, be sure to:

- Shut down PTO.
- Shut off vehicle's engine, and unit's engine if applicable.
- Place vehicle transmission in "Neutral" or "Park".
- Set parking brake firmly.
- Remove ignition key and take it with you.
- Block wheels.

These actions are recommended to avoid unauthorized use, runaway, vandalism, theft and unexpected operation during startup.

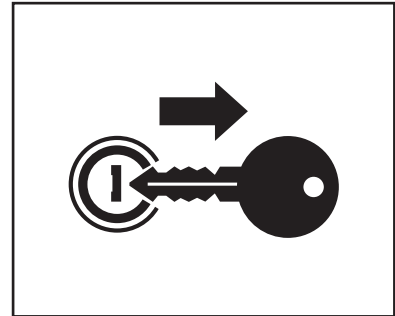

Figure 4.1

SUPPORT MACHINE PROPERLY

Figure 4.2 - When machine is removed from vehicle, always store on adequate supports on a firm level surface. Improper supporting or storage of spreader may cause machine to fall, resulting in serious injury or death.

Never use lifting device to free machine from a chassis, storage stands or frozen ground, or to lift the chassis in any way. Shock loading is prohibited and sudden accelerations must be avoided. Lifting in such a manner could result in injury or machine damage.



Figure 4.2

DISPOSE OF WASTE PROPERLY

Figure 4.3 - Improper disposal of waste can threaten the environment and ecology. Potentially harmful waste used with equipment include items such as fuel, oil, filters and batteries.

Use leakproof containers when draining fluids. Do not use food or beverage containers that may mislead someone into drinking from them. Do not pour waste onto the ground, down a drain, or into any water source.

Inquire on proper disposal methods from your local environmental or recycling center, or from your local dealer.

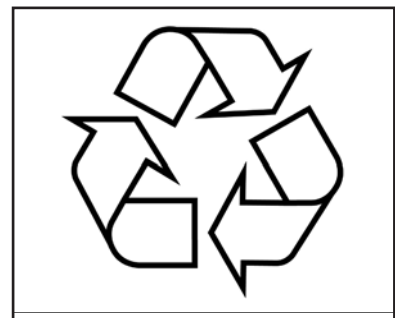

Figure 4.3

Safety Decal Maintenance

Keep safety decals and signs clean and legible at all times.

Replace safety decals and signs that are missing or have become illegible.

Replaced parts that displayed a safety sign should also display the current sign.

Safety decals or signs are available from your dealer's Parts Department or from New Leader Manufacturing by calling (800) 363-1771.

Safety Decal Installation

Clean Surface

Wash the installation surface with a synthetic, free-rinsing detergent. Avoid washing the surface with a soap containing creams or lotion. Allow to dry.

Position Safety Decal

Decide on the exact position before application. Application marks may be made on the top or side edge of the substrate with a lead pencil, marking pen, or small pieces of masking tape. NOTE: Do not use chalk line, china marker, or grease pencil. Safety decals will not adhere to these.

Remove the Liner

A small bend at the corner or edge will cause the liner to separate from the decal. Pull the liner away in a continuous motion at a 180-degree angle. If the liner is scored, bend at score and remove.

Apply Safety Decal

Tack decal in place with thumb pressure in upper corners. Using firm initial squeegee pressure, begin at the center of the decal and work outward in all directions with overlapping strokes. NOTE: Keep squeegee blade even—nicked edges will leave application bubbles. Pull up tack points before squeegeeing over them to avoid wrinkles.

Remove Pre-mask

If safety decal has a pre-mask cover remove it at this time by pulling it away from the decal at a 180 degree angle. NOTE: It is important that the pre-mask covering is removed before the decal is exposed to sunlight to avoid the pre-mask from permanently adhering to the decal.

Remove Air Pockets

Inspect the decal in the flat areas for bubbles. To eliminate the bubbles, puncture the decal at one end of the bubble with a pin (never a razor blade) and press out entrapped air with thumb moving toward the puncture.

Re-Squeegee All Edges

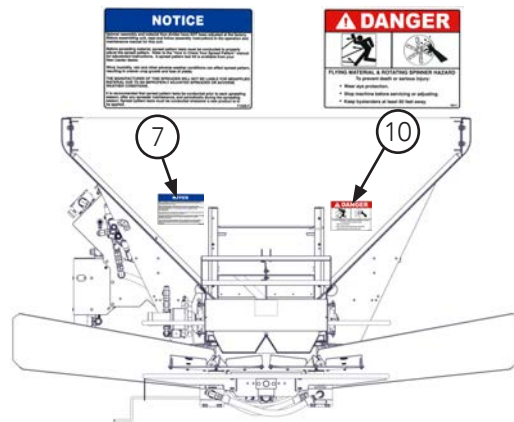
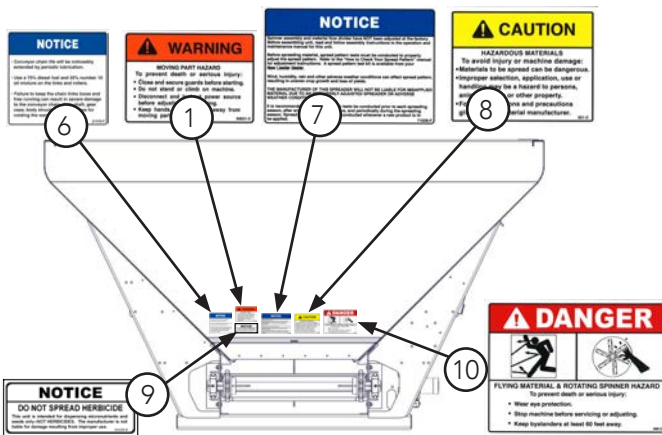
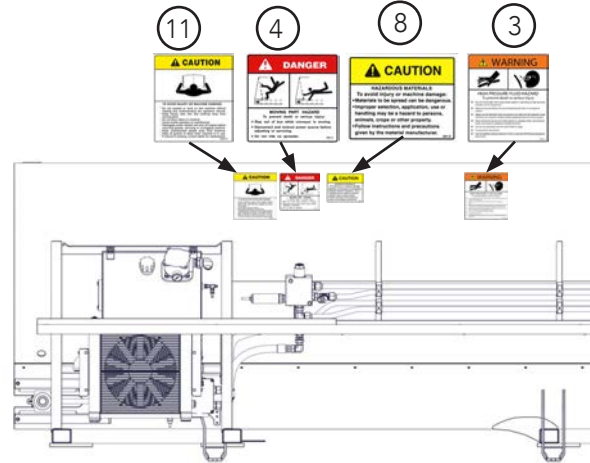
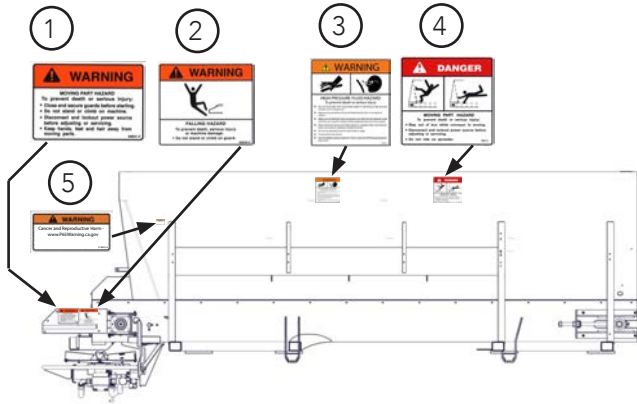

1. WARNING: MOVING PART HAZARD**To prevent death or serious injury:**

- Close and secure guards before operating machine.
- Do not stand or climb on machine.
- Disconnect and lockout power source before adjusting or servicing.
- Keep hands, feet and hair away from moving parts.

2. WARNING: FALLING HAZARD**To prevent death, serious injury or machine damage:**

- Do not climb or stand on guard.

3. WARNING: HIGH-PRESSURE FLUIDS**To prevent death or serious injury:**

- Do not check for leaks with hands while system is operating as high pressure oil leaks can be dangerous!
- Relieve system pressure before disconnecting hydraulic lines or working on system.
- Make sure all hydraulic fluid connections are tight and all hydraulic hoses and lines are in good condition before applying pressure to the system.
- Wear protective gloves and safety glasses or goggles when searching for leaks. Use wood or cardboard instead of hands.
- Do not use hydraulic lines for hand holds or steps.
- Components may be hot.
- Get immediate medical attention if skin is pierced with fluid as gangrene may result.

4. DANGER: MOVING PART HAZARD**To prevent death or serious injury:**

- Stay out of box while conveyor is moving.
- Disconnect and lock out power source before adjusting or servicing.
- Do not ride on the spreader.

5. WARNING: HAZARDOUS MATERIALS**To avoid injury:**

- Cancer and Reproductive Harm - www.P65Warning.ca.gov

6. NOTICE: CONVEYOR CHAIN LUBRICATION**To avoid machine damage and premature wear:**

- Conveyor chain life will be noticeably extended by periodic lubrication.
- See "Lubricant & Hydraulic Oil Specifications" in this manual for details.
- Failure to keep the chain links loose and free running can result in severe damage to the conveyor chain, drag shaft, gearcase and body structure, and is cause for voiding the warranty.

7. NOTICE: SPREAD PATTERN TESTING**To obtain optimal machine performance:**

- Spinner assembly and material flow divider have NOT been adjusted at the factory. Before assembling unit, read and follow assembly instructions in the operation and maintenance manual for this unit.
-
- Before spreading material, spread pattern tests must be conducted to properly adjust the spread pattern. Refer to the "How to Check your Spread Pattern" manual for adjustment instructions. A spread pattern test kit is available from your New Leader dealer.
-
- Wind, humidity, rain and other adverse weather conditions can affect spread pattern, resulting in uneven crop growth and loss of yields.
-
- THE MANUFACTURER OF THIS SPREADER WILL NOT BE LIABLE FOR MISAPPLIED MATERIAL DUE TO AN IMPROPERLY ADJUSTED SPREADER OR ADVERSE WEATHER CONDITIONS.
-
- It is recommended that spread pattern tests be conducted prior to each spreading season, after any spreader maintenance, and periodically during the spreading season. Spread pattern tests must be conducted whenever a new product is to be applied.

8. CAUTION: HAZARDOUS MATERIALS**To avoid injury or machine damage:**

- Materials to be spread can be dangerous.
- Improper selection, application, use or handling may be hazardous to persons, animals, crops or other property.
- Follow instructions and precautions given by material manufacturer.

9. NOTICE: DO NOT SPREAD HERBICIDE**To avoid machine damage and premature wear:**

- This unit is intended for dispensing micronutrients and seeds only--NOT HERBICIDES. The manufacturer is not liable for damage resulting from improper use.

10. DANGER: FLYING MATERIAL AND ROTATING SPINNER HAZARD**To prevent death or serious injury:**

- Wear eye protection.
- Stop machine before servicing or adjusting.
- Keep bystanders at least 60 feet away.

11. CAUTION: TO AVOID INJURY OR MACHINE DAMAGE:

- Do not operate or work on this machine without reading and understanding the operator's manual.
- Keep hands, feet, hair and clothing away from moving parts.
- Do not allow riders on machine.
- Avoid unsafe operation or maintenance.
- Disengage power takeoff and shut off engine before removing guards, servicing or unclogging machine.
- Keep unauthorized people away from machine.
- Keep all guards in place when machine is in use.
- If operator's manual is missing, contact your local New Leader dealer or print a new copy from www.highwayequipment.com.

This page is intentionally left blank.

Recommended sequence of installation is:

1. Mounting of PTO and pump.
2. Installation of radar (if applicable)
3. Mounting of spreader.
4. Installation of controller.
5. Installation of chassis hydraulic hose and electrical wiring to spreader.
6. Installation of optional parts.
7. Filling of hydraulic reservoir and lubrication.
8. Checking for leaks and proper functioning.

NOTICE! Pump and truck requirements must be determined prior to installation of the spreader.

Hydraulic Requirements

Hydraulics		GPM (LPM) (Gallons/Liters per Minute)	Maximum Pressure (PSI)
L4000G4	Spinner & Conveyor	40 (151.4)	3100
	MultApplier	9 (34.1)	1500
L4000G4 HP	Spinner	40 (151.4)	3100
	Conveyor	20 (75.7)	3400
	MultApplier	20 (75.7)	1500

HECO Pump Part Numbers	Pump CID	Theoretical Pump GPM (LPM) 100% Efficiency	Pump RPM
86665	4.38	40 (151.4)	2100
304424 (Front Tandem Section)	4.46	40 (151.4)	2075
304425 (Rear Section for Insert)	0.93	9 (34.1)	
304426 (Rear Section for HP Hydraulics)	2.17	20 (75.7)	

*Requires higher RPM to achieve GPM

Truck Requirements

Before mounting the spreader on a truck, the following major questions must be considered:

1. Is the CA (Cab to Axle) dimension of the truck correct for the length of the spreader?
2. The Dimensions and Capacities chart in the operator's manual will assist in matching spreader to truck.
3. Is the truck's GAWR (Gross Axle Weight Rating) and the GVWR (Gross Vehicle Weight Rating) adequate to carry the fully loaded spreader?
4. Refer to your New Leader dealer to find the GAWR and GVWR for most trucks, and how to calculate the weight distribution on each axle and total loaded vehicle weight.

Truck Frame Length

Refer to “Dimensions & Capacities” section in the operator’s manual for approximate length from the rear of the cab to the rear end of the frame. Shorten truck frame as necessary, making sure to follow truck manufacturer’s specifications so as not to void truck warranty.

NOTICE! Do not weld to truck frame; it may void truck warranty.

A level top surface is necessary for mounting. Add steel shim bars or strips the same thickness as fish plates or other obstructions and as wide as the truck frame channel top flange. Shims must be drilled to clear any rivet or bolt heads.

Lifting the Spreader



WARNING

Use only lifting devices that meet or exceed OSHA standard 1910.84 or ASME B30.20-2006. Never lift equipment over people. Never lift unit with anything or anybody in the body. Loads may shift or fall if improperly supported, causing damage to unit, injury or even death.



CAUTION

Do not use lifting device to free unit from a chassis, storage stands or frozen ground, or to lift the chassis in any way. Shock loading is prohibited and sudden accelerations should be avoided. Lifting in such a manner could result in damage to unit or injury.

Always inspect unit lift points for signs of wear, cracking, corrosion, gouges, alterations, or distortion.

Always use a sling, spreader bar, or lifting bar that attaches to the lifting points with a minimum of 60 degrees from horizontal. It is preferable to use an “H” style lifting bar that keeps the attaching chains in a near vertical orientation as shown in Figure 1. Operators of lifting devices must be qualified and knowledgeable in their use and application.

Position the chassis with adequate room around the unit. Work in an environment that permits clear communication to others nearby. Keep area clear of persons when loads are to be lifted and suspended. Do not allow the lifted load to come in contact with any obstruction.

Store units on a solid surface using appropriate storage stands when not installed.

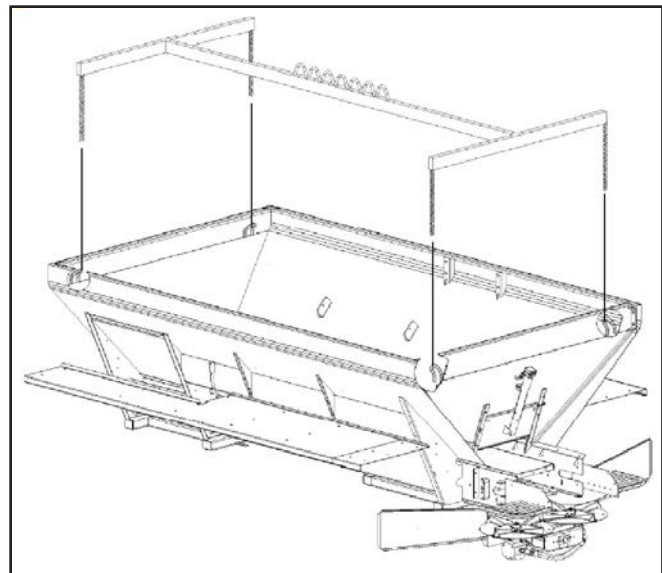

Figure 1 - Lifting Bar

Installing Body**CAUTION**

Be careful when drilling so as to not damage truck frame, gas tank, or any other important components.

NOTICE!

DO NOT WELD ON VEHICLE FRAME! Such welding can lead to fatigue cracking and must be avoided.

NOTICE!

DO NOT PUT HOLES INTO TOP OR BOTTOM FLANGES—to do so may void truck manufacturer's warranty. When drilling holes in frame member, drill only through vertical web portions.

NOTICE!

Connect welders ground directly to one of the items being welded anytime an arc welder is used on the vehicle or anything connected to the vehicle. Refer to Manufacturer's instructions.

IMPORTANT!

Disconnect electrical components from electrical system when welding on equipment to prevent component damage due to power surges or excessive current.

Front Mount Angles

Assemble two front mounting angle springs and hardware. Use a 3/8" (10mm) shim between cross tube mounting plate and truck frame mounting angle. Position assembly under second cross tube from front and against truck frame, make sure springs do not contact cross tube. Mark position of mounting angle holes on truck frame. Drill 9/16" (14mm) holes where marked and install mounting assembly using 1/2" hardware supplied. Weld mounting plate to bottom of cross tube on three sides, and remove 3/8" (10mm) shim (Figure 2). Tighten spring assembly until spring compressed height is 4" (102cm). There should be a 3/8" (10mm) space between cross tube mounting plate and truck frame mounting angle (Figure 2). Repeat this procedure on other side of truck frame, on same cross tube.

NOTE: It may be necessary to mount front mounting angle springs on first cross tube on some vehicles due to obstructions such as spring shackles, etc.

Center Mount Plates

Position center mounting plates at second cross tube from rear with slotted faces against truck frame and mark location of slots on truck frame. Drill 9/16" (14mm) diameter holes through truck frame, approximately (19mm) from bottom of slots (Figure 2). Weld mounting angle to bottom of cross tube on 3 sides (Figure 4). Install hardware and tighten to recommended torque.

Rear Mount Angles

Position rear mounting angles with the slotted faces against the side of the truck frame and centered on rear cross sill. Mark slot locations on truck frame. Drill 9/16" (14mm) diameter holes through truck frame at bottom end of slots (Figure 3). Weld mounting angle to bottom of cross tube on three sides (Figure 4). Install hardware and tighten to recommended torque.

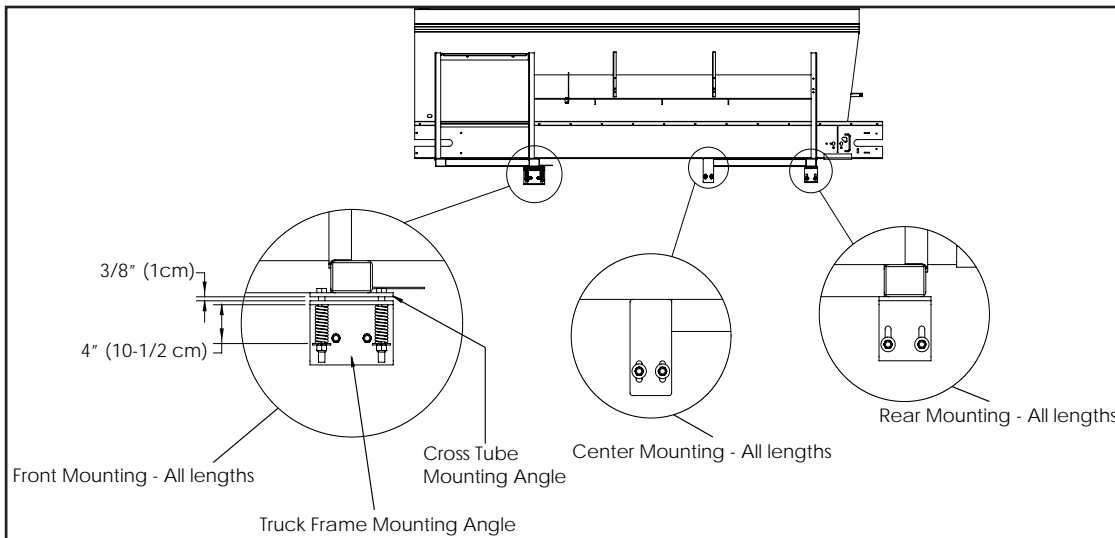

Figure 2 - Mounting Angle Installation - NL4500G4 Edge

Securing to Frame

Install mounting angles and tighten mounting bolts to recommended torque. Weld mounting angles to spreader cross tubes by welding on front, outer and rear sides (Figure 3). Make sure welds between mounting angles and spreader cross tubes are sound full fillet welds. Center mounting angles on tubes (as shown in Figure 3) so full fillet welds can be made on three sides. An edge bead weld is not a satisfactory weld for this service. Use E70S rod/wire for carbon steel to carbon steel and 309 rod/wire for carbon steel to stainless steel. Use 309 rod/wire to weld stainless steel to stainless steel.

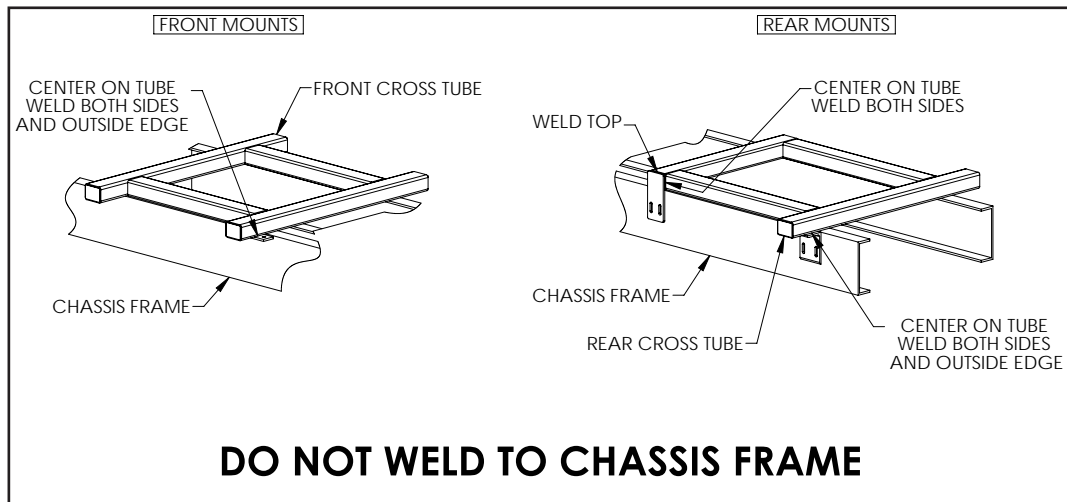
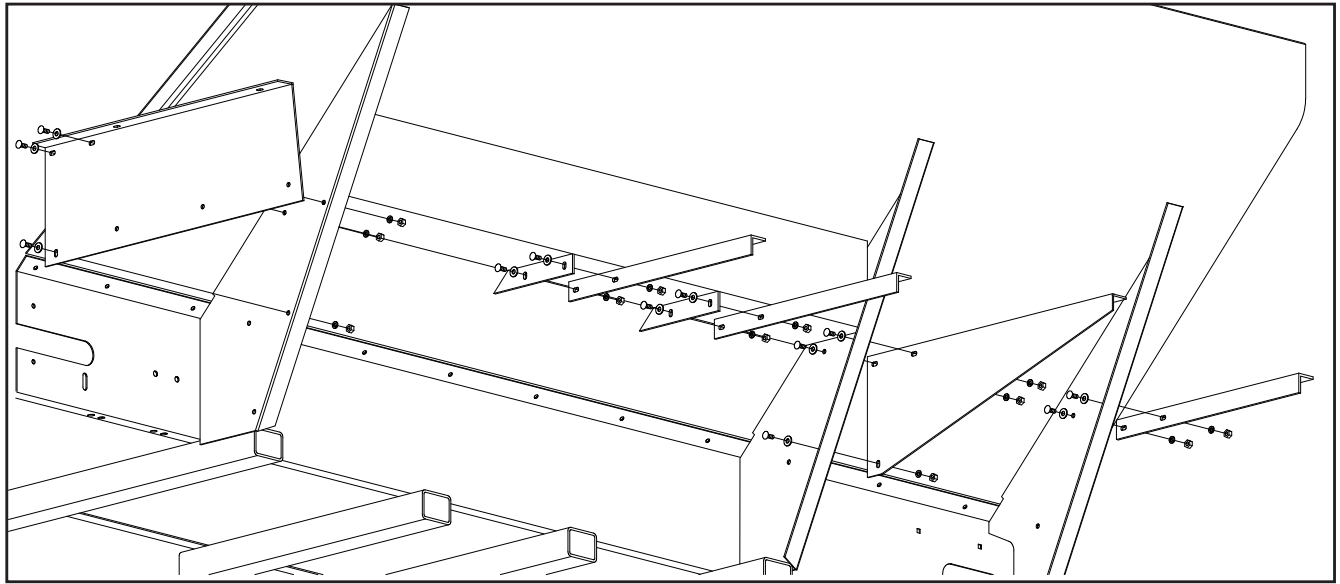
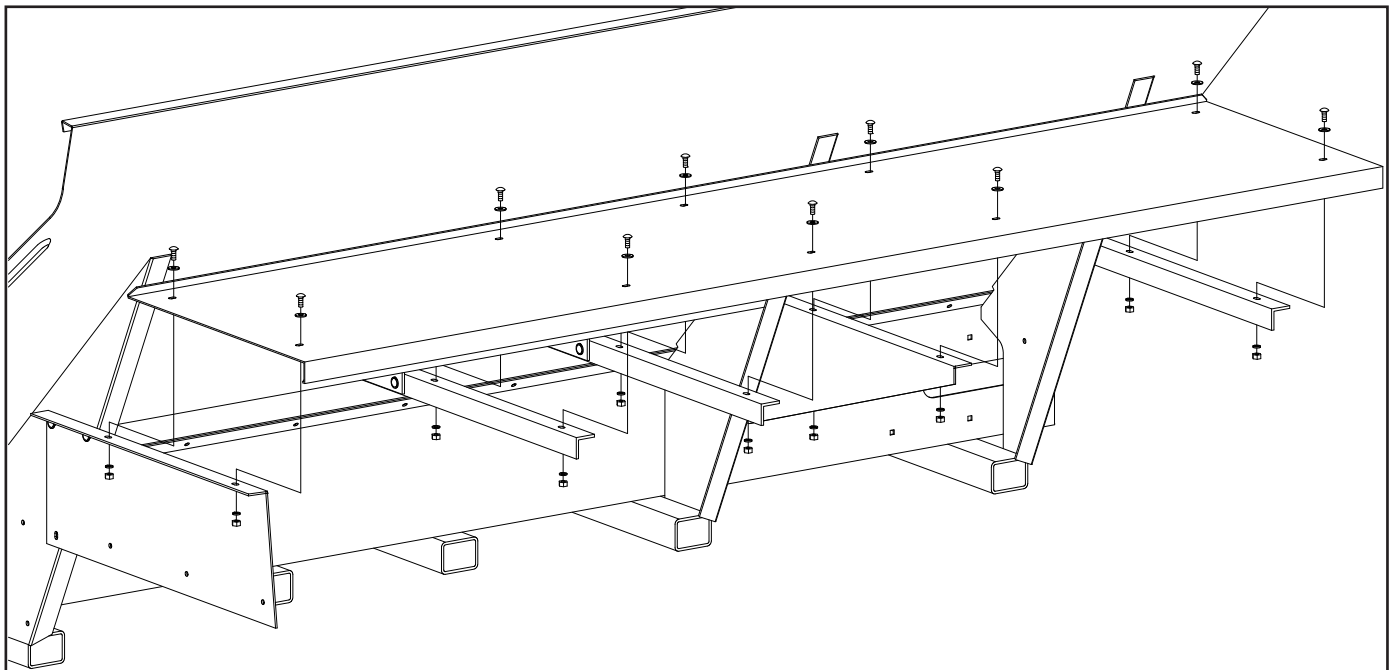

Figure 3 - Welding Instructions

Fender Installation



*Figure 4 - Fender Angle Installation



*Figure 5 - Fender Installation

* - Fenders may not be as shown

Attach fender angles and panels on spreader body stakes as shown in Figure 4. Do not tighten hardware at this time.

Attach fenders on top of angles/panels as shown in Figure 5. Tighten all hardware.

This page is intentionally left blank.

Hydraulic Hose Installation



CAUTION

If a threaded connection is tightened too tightly, the fitting or housing into which the fitting is placed could be distorted and an unstoppable leak could occur.



WARNING

Do not use one manufacturer's hose with another manufacturer's fittings! Such will void any warranty and may cause premature burst or leak of hydraulic fluids! Severe injury and/or fire could result!

Determine pressure port of pump. Install pressure hose into this port as shown in Figure 6. Connect suction hose to opposite port and to tank outlet on hydraulic tank. Use plastic tie straps as necessary to support hoses so they will not catch on field obstructions or contact hot or moving parts.

Hydraulic Pump Installation

HECO pumps are direct mount. See "Pump Hydraulics" in the spreader parts manual for assembly instructions.

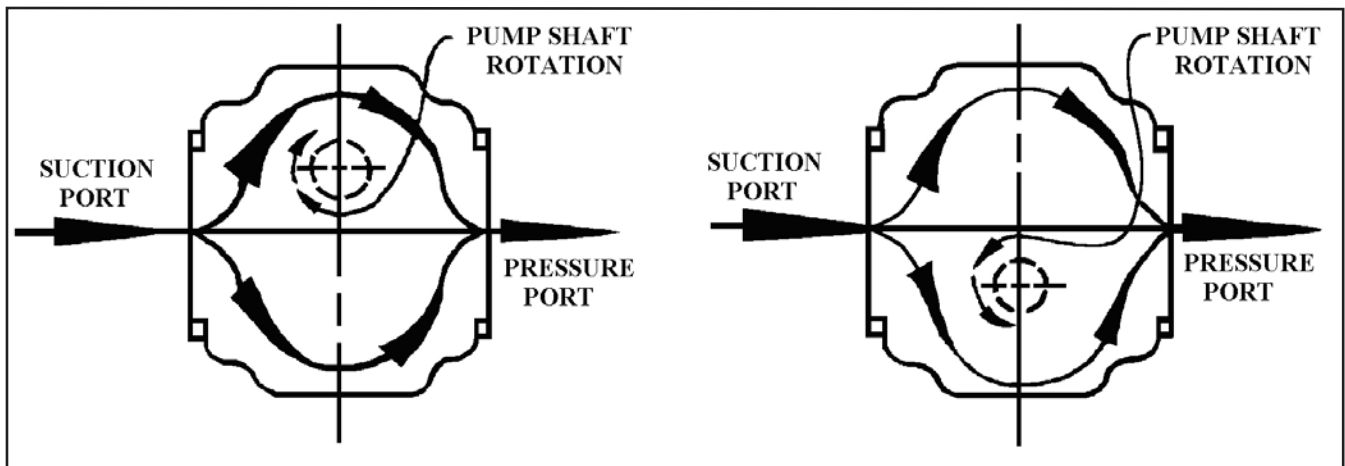

Figure 6 - Hydraulic Pump Installation

Use thread sealer on all NPT fittings. When using thread sealer, do not put it on the first three threads of the fitting. Too much on the fitting or on the first three threads will force it into the oil stream where it could damage the system.

Assemble system as shown in "Hydraulics" parts list in the parts manual. Place hose clamps as needed to keep hoses away from hot or moving parts. Do not let hoses hang so low as to be snagged. Do not stretch hoses tight.

Hydraulic hoses are as follows:

- Pressure Line: High pressure hose supplied by dealer. Hose must have minimum pressure rating that corresponds to the maximum pressure setting of the hydraulic system. Refer to "Hydraulic Requirements" on page 25.
- Suction Line: Suction hose supplied by dealer. Hose must meet or exceed SAE 100R4 requirements.

Hydraulic Hose Installation Guide

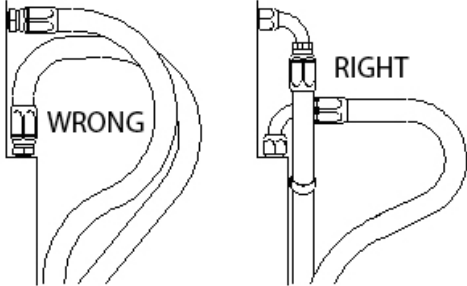
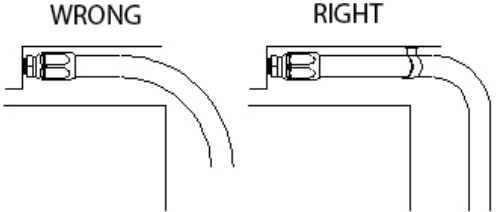
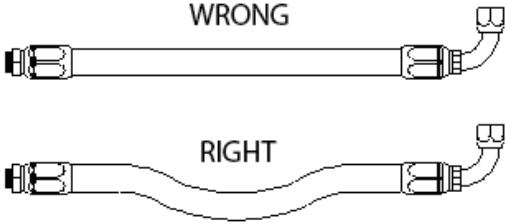
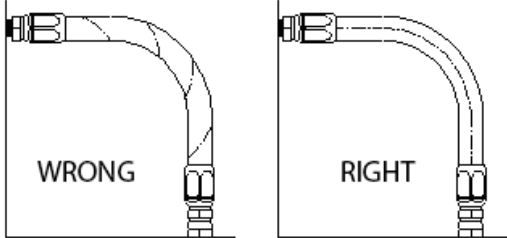
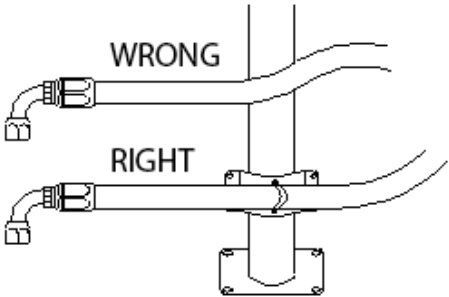
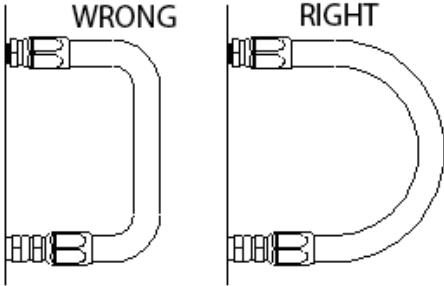
	
<p>1. Use elbows and adapters in the installation to relieve strain on the assembly, and to provide easier and neater installations that are accessible for inspection and maintenance. Remember that metal end fittings cannot be considered as part of the flexible portion of the assembly.</p>	<p>2. Install hose runs to avoid rubbing or abrasion. Clamps are often needed to support long runs of hose or to keep hose away from moving parts. It is important that the clamps be of the correct size. A clamp that is too large will allow the hose to move in the clamp causing abrasion at this point.</p>
	
<p>3. In straight hose installations allow enough slack in the hose line to provide for changes in length that will occur when pressure is applied. This change in length can be from +2% to -4%.</p>	<p>4. Do not twist hose during installation. This can be determined by the printed layline on the hose. Pressure applied to a twisted hose can cause hose failure or loosening of the connections.</p>
	
<p>5. Keep hose away from hot parts. High ambient temperature will shorten hose life. If you cannot route it away from the heat source, insulate it.</p>	<p>6. Keep the bend radii of the hose as large as possible to avoid hose collapsing and restriction of flow. Follow catalog specs on minimum bend radii.</p>

(Used with the permission of The Weatherhead Company.)

Hydraulic Drain Lines

See "Hydraulic Reservoir" and "Pump Hydraulics" in the parts manual for illustrations.

Filling Hydraulic System

NOTICE!

DO NOT attempt to run pump without first filling hydraulic reservoir and opening suction line valve, or damage to pump may occur.

Fill reservoir with hydraulic oil as specified in the "Lubrication and Maintenance" section in the operator's manual. Be sure oil is clean, free from dirt, water and other contaminants.

Lubricate all points necessary per Lubrication Chart in "Lubrication and Maintenance" section of operator's manual.

Electrical Connections

Connect all electrical control circuits. All wiring should be approved automotive insulated wire, supported adequately with insulating ties or straps, and located where it will not interfere with any control or access. Make sure wiring does not contact any moving parts or sharp edge and is kept away from any hydraulic line or any heated part.

Light Installation

**CAUTION**

All holes in truck cab walls, floor and firewall are to be grommeted, plugged and sealed to prevent entrance of engine fumes, dust, dirt, water and noise.

Light installation must comply with all applicable requirements prescribed by FMVSS/CMVSS 108, ASABE S279, state and local regulations. See "Lights" parts page in the operator's manual for illustrations if applicable.

Recommended sequence of installation is:

1. Spreader preparation.
2. Insert preparation.
3. Mounting of insert.
4. Connecting hydraulic hoses.
5. Installation of hillside divider and conveyor cover.
6. Checking installation.
7. Checking for leaks and proper functioning.

Hydraulic Requirements

Refer to "Hydraulic Requirements" on page 25 for hydraulic pump part numbers and specifications required for insert installation.

Spreader Preparation



WARNING

Use only lifting devices that meet or exceed OSHA standard 1910.184. Never exceed work load limits or lift equipment over people. Empty spreader before lifting. Loads may shift or fall if improperly supported, causing injury.

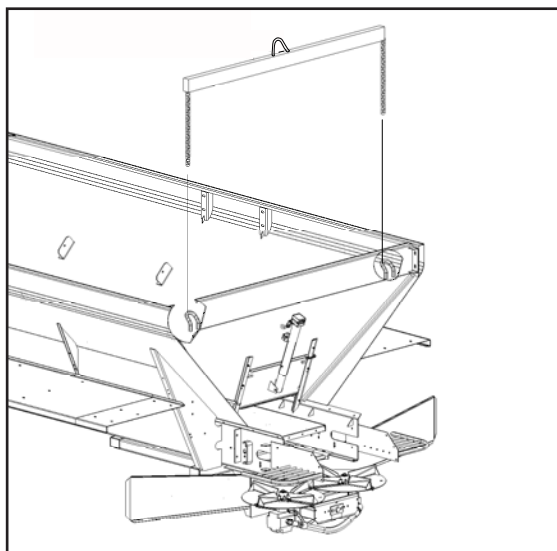

Figure 1

Remove the Inverted "V" and Hillside Divider from the spreader, if so equipped, and set hardware aside.

Remove Feedgate Jack Handle and set aside. Support endgate by attaching a hoist to the lift hooks. Remove hardware from both sides of the endgate and carefully remove from the spreader as shown in Figure 1.

NOTE: Always use a sling, spreader bar, or lifting bar that attaches to the lifting points with a minimum of 60 degrees from horizontal. It is preferable to use a straight style lifting bar that keeps the attaching chains in a near vertical orientation.

NOTE: Always inspect unit lift hooks for signs of wear, cracking, corrosion, gouges, alterations, or distortion before use.

NOTICE!

The MULTAPPLIER is available in two different styles; Style I and Style II. The Style II MULTAPPLIER provides higher output capabilities. Refer to next page to determine your style of MULTAPPLIER insert.

Style I

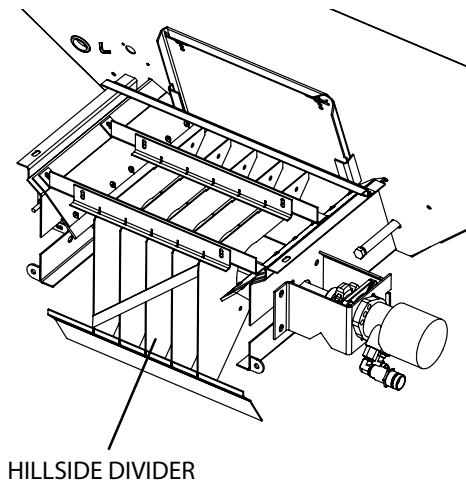
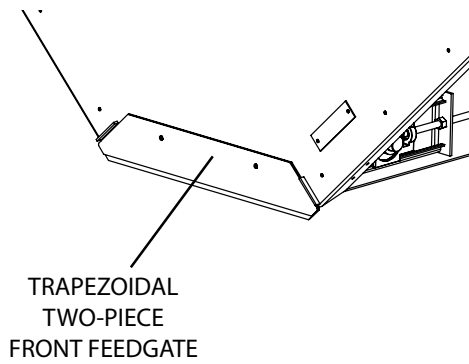
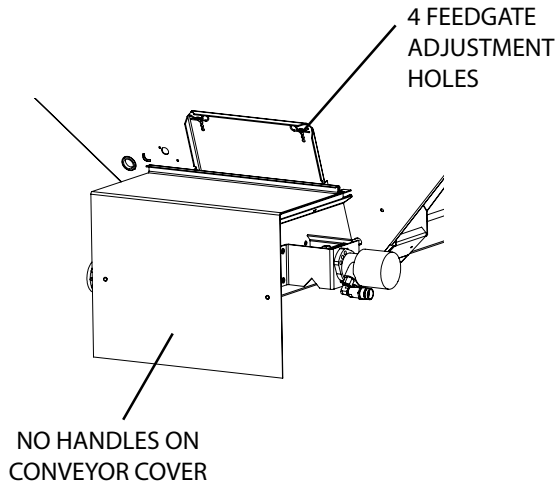

Style II

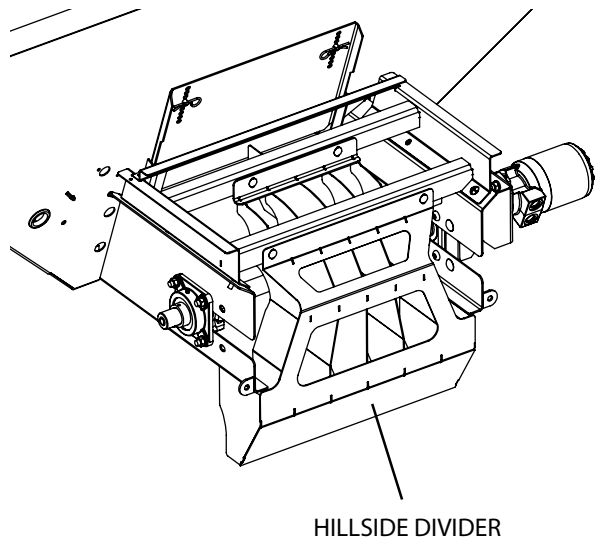
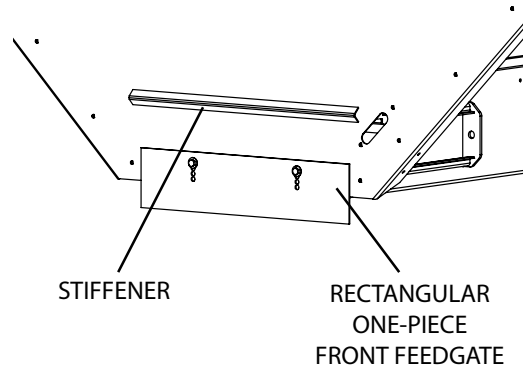
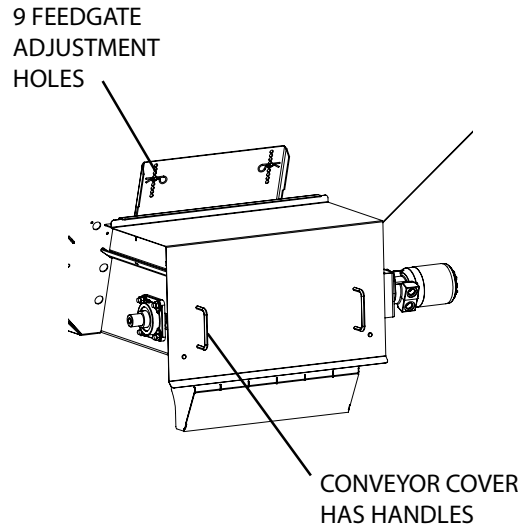

Feedgate Adjustment



WARNING

Stay out of the spreader. If it's necessary to enter the spreader, return to the shop, empty body, turn off all power, set vehicle brakes, lock engine starting switch and remove keys before entering. Tag all controls to prohibit operation. Tags should be placed, and later removed, only by person working in the body.

Adjust the insert's front feedgate prior to installation.

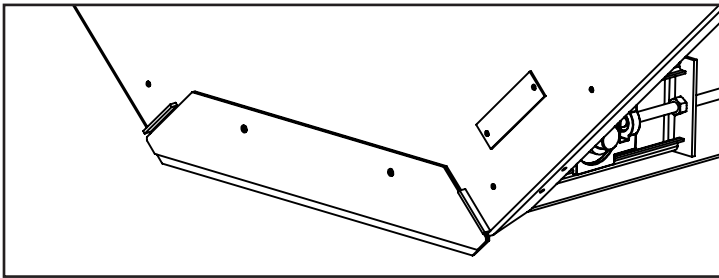

Figure 2A - 1 1/2" (3.81 cm) or 2" (5.08 cm) Opening
(Style I MULTAPPLIER)

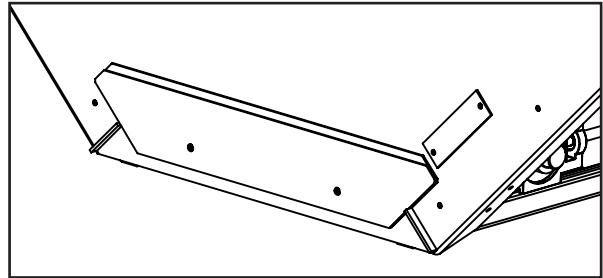

Figure 2B - 3" (7.62 cm) Opening
(Style I MULTAPPLIER)

Style I MultApplier - To adjust main bin's feedgate opening on a Style I MultApplier-equipped unit: position front feedgates on MultApplier as necessary to achieve a 1-1/2 inch (3.81 cm), 2 inch (5.08 cm) (Figure 2A) or 3 inch (7.62 cm) (Figure 2B) opening. Position both feedgates with short side down for a 3" (7.62 cm) opening. NOTE: Both feedgates are installed for shipping.

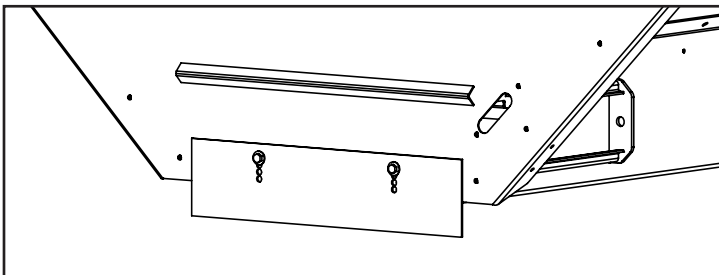

Figure 3A - 2 1/2" (3.81 cm) or 2" (5.08 cm) Opening
(Style II MULTAPPLIER/MULTIBIN)

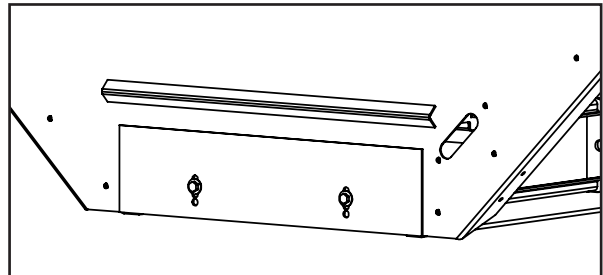

Figure 3B - 4" (10.16 cm) Opening
(Style II MULTAPPLIER/MULTIBIN)

Style II MultApplier/MultiBin - To adjust main bin's feedgate opening on a Style II MultApplier or MultiBin-equipped unit: position front feedgate on insert as necessary to achieve a 1 1/2 inch (3.81 cm) (Figure 3A) to 4 inch (10.16 cm) (Figure 3B) opening in 1/2 inch increments.

NOTE:

Visit www.newleadervip.com and enter parameters to determine minimum and maximum application rates and feedgate openings for optimal performance of your spreader.

Insert Installation



WARNING

Use only lifting devices that meet or exceed OSHA standard 1910.184. Never exceed work load limits or lift equipment over people. Empty spreader before lifting. Loads may shift or fall if improperly supported, causing injury.

Before installing the insert:

Parts Needed:

Description	Qty
MultApplier	1
Capscrew - 1/2 x 1 1/4 Grade 8	8
Flat Washer - 1/2 Grade 8	16
Lock Washer - 1/2 Grade 8	8
Hex Nut - 1/2 Grade 8	8

1. Make sure rubber sealer hardware is loose. If not, loosen.

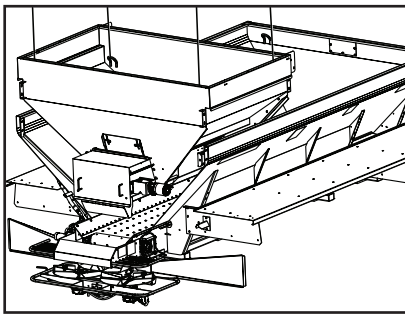

Figure 4A



Figure 4B

2. To install insert:
 - a. Figure 4A - Hoist insert into position and slide between main bin's side sheets.
 - b. Figure 4B - Align insert's and main bin's front and rear mount brackets.
 - c. Make sure insert is resting on inside of main bin, and not resting on tops of side sheets.
 - d. Release tension on hoist but do not remove.



Figure 5A (uninstalled)

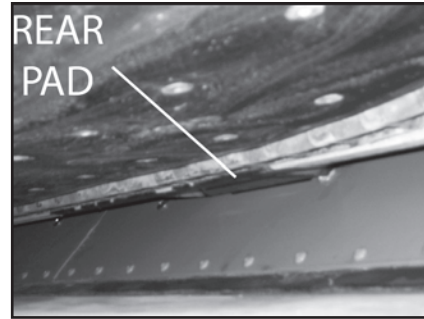

Figure 5B (shown installed)
View from rear of unit.

Figures 5A-5B - Visually make sure insert is centered from side to side in main bin and rear pads are resting on main bin.

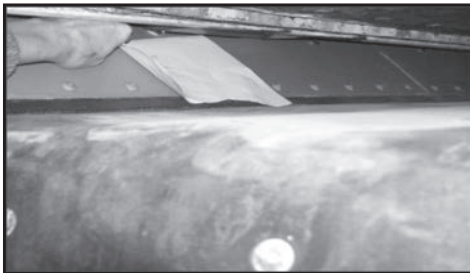

Figure 6



Figure 7

Figure 6 - There must be contact between rear pads and main unit. Check for contact by trying to slide paper between pads and main bin. If no contact, adjust insert.

Figure 7 - Inside main unit, locate front pads by lifting rubber sealers on front endgate.



Figure 8A



Figure 8B

1. Figures 8A-8B - There must be contact between front pads and main bin. Check for contact by trying to slide paper between pads and main bin. If no contact, adjust insert.

NOTE: Pry insert at mount brackets if necessary.



Figure 9



Figure 10



Figure 11

2. Figure 9 - Once both front pads make contact, insert hardware in front mount brackets' lower holes. Shim between main bin and insert brackets if distance is larger than 1/8" (.32cm). Tighten hardware per torque recommendations in this manual.
3. Figure 10 - Make sure front feedgate is level. Lower endgate sealers so flush with chain shields and tighten hardware.

NOTICE!

Leakage of material may occur if the sealer belts are not set properly on the front of the insert. Highway Equipment Company is not liable for lost material due to improperly installed sealer belts.

4. Figure 11 - Make sure there is a complete seal covering the gap between the insert and the main bin's side sheets. Tighten all hardware on rubber sealers at front of insert.
5. Make sure rear pads are still in place against main bin. Install hardware in lower holes of rear mount brackets. Shim between main bin and insert brackets if distance is larger than 1/8" (.32cm). Tighten hardware per torque recommendations in this manual.
6. Make sure insert's side sheets are not resting on top of main bin's side sheets.
7. Install hardware in all four mount brackets' upper holes. Tighten hardware per torque recommendations.
8. Remove hoist.
9. Inspect unit for foreign debris in conveyor area.

Lower Divider - Multibin

The following steps apply to MULTIBIN units only. Continue to "Hydraulics" for MULTAPPLIER units.

NOTICE!

Highway Equipment Company will not be liable for misapplied material due to an improperly adjusted divider, spreader or both.

Parts Needed:

Description	Qty
Divider - Lower Weldment	1
Capscrew - 5/16 x 1	4
Washer - Flat 5/16	8
Nut - Lock 5/16 SS	4

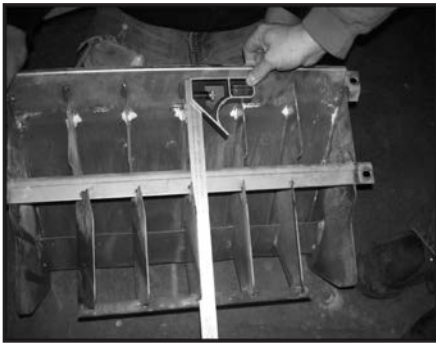

Figure 12

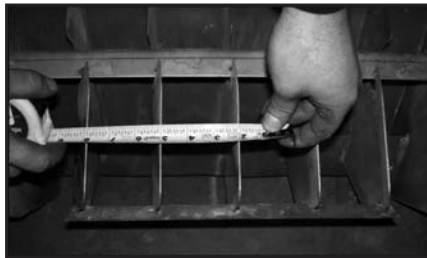

Figure 13



Figure 14

1. Figure 12 - Make sure center fin is square to rear panel.
2. Figure 13 - Measure distance between Lower Divider fins to make sure they are all 3" (8cm) apart. Adjust top of fin as necessary.
3. Figure 14 - Slide Lower Divider between bottom of MULTIBIN and Spinner Divider as shown.



Figure 15



Figure 16

4. Figure 15 - Lift Lower Divider to bottom of MULTIBIN, align holes and loosely install front and rear hardware.
5. Figure 16 - Verify Lower Divider is square by measuring from each side to main bin's chain shields. Make sure distances are equal.
6. Make sure Lower Divider is centered over Material Divider. Contact Highway Equipment Company if they cannot be aligned.
7. Tighten front and rear hardware per torque recommendations. Refer to "Standard Torques" in the "Lubrication and Maintenance" section of the spreader manual.

Hydraulics

Attach insert hoses to spreader hoses as shown in Figures 17A - 17C as applicable. Plug in rate sensor.

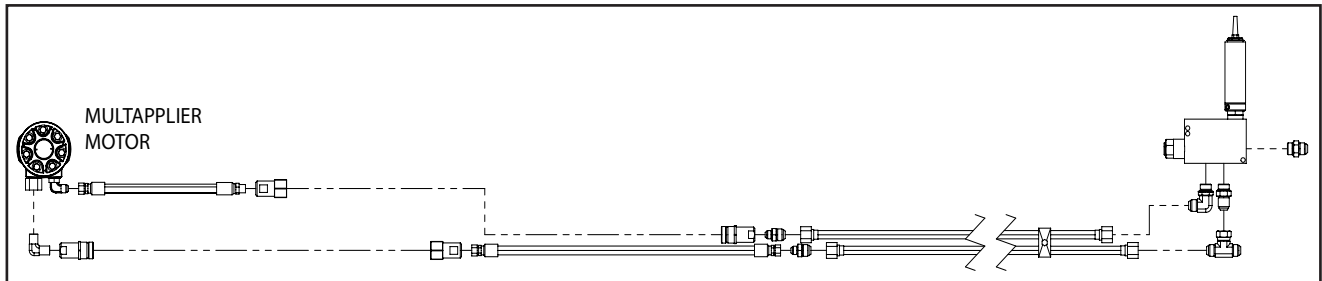

Figure 17A - MULTAPPLIER Operation

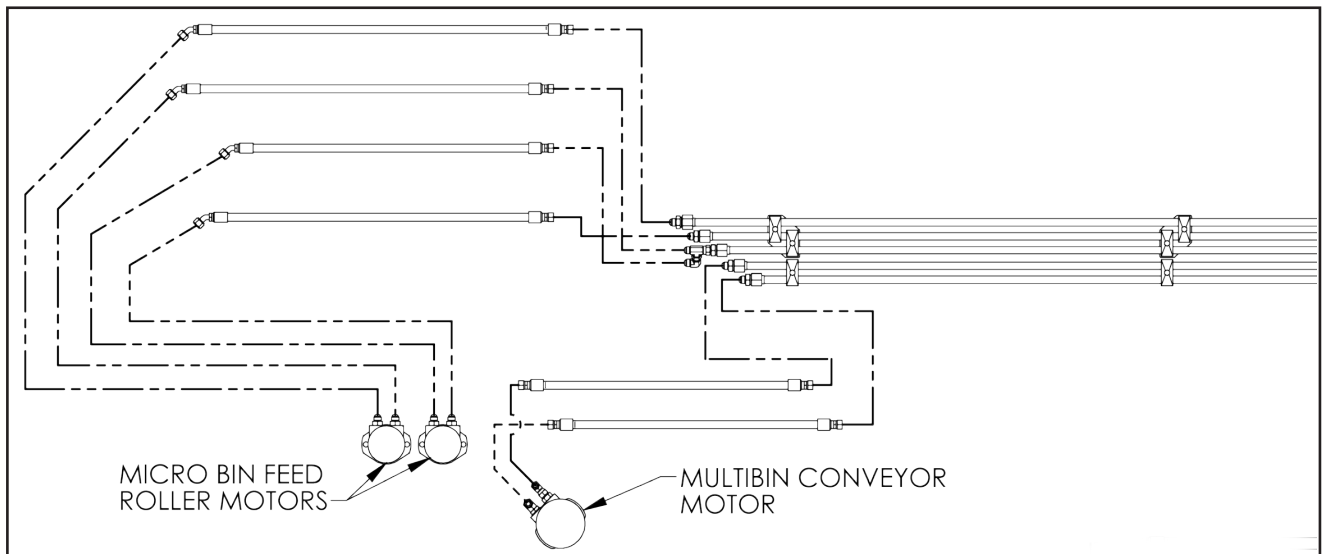

Figure 17B - MULTIBIN Operation Dual Micro

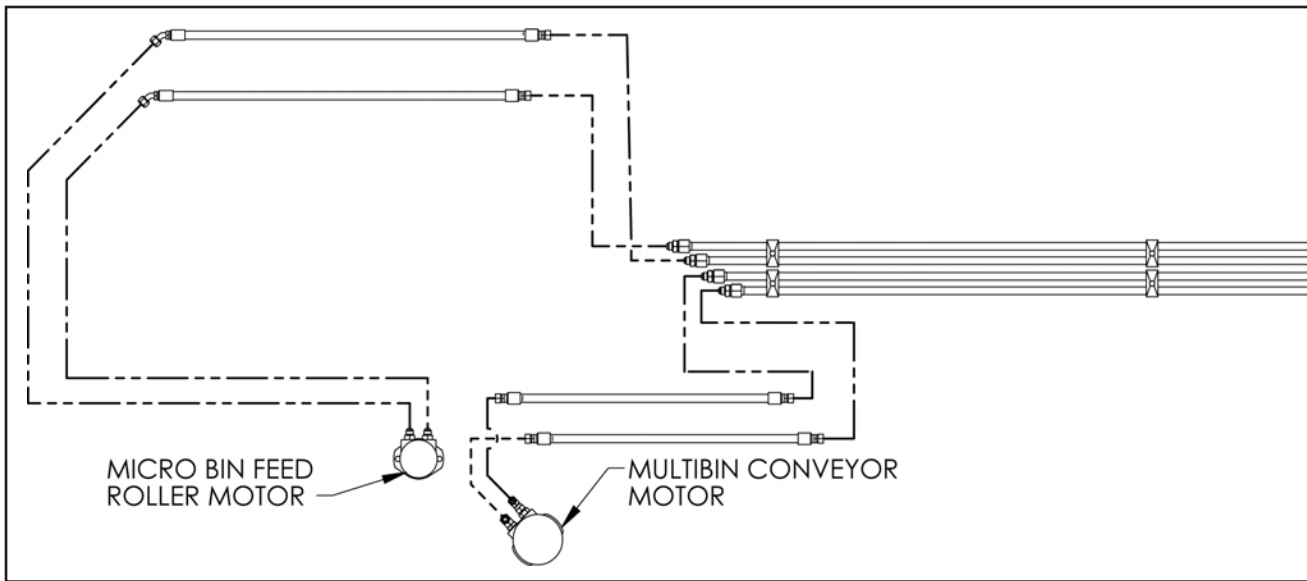

Figure 17C – MULTIBIN Operation Single Micro

Hydraulic Hose Installation

Refer to “Installation Guide” for proper hydraulic hose installation guidelines.

If insert was purchased separately from spreader, refer to parts pages for hydraulic installation. Install valve mounting bracket on two right hand front stakes as shown in Figure 18 (MultiBin installation shown).

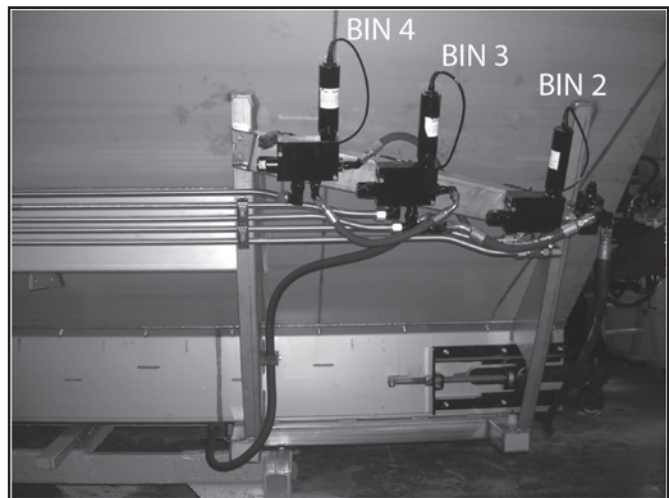

Figure 18 - Hydraulic Installation

Hillside Divider & Conveyor Cover - MultiApplier

The following steps apply to MULTAPPLIER units only. Continue to "Micro Cover Installation" for MULTIBIN units.

NOTICE!

Highway Equipment Company will not be liable for misapplied material due to an improperly adjusted divider, spreader or both.

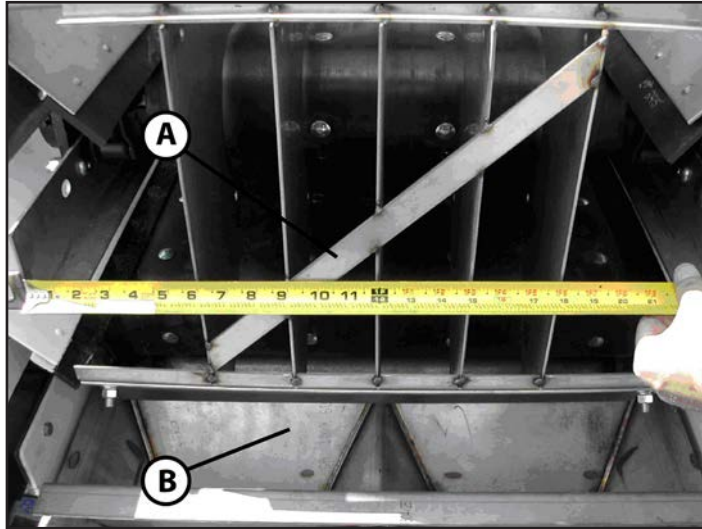
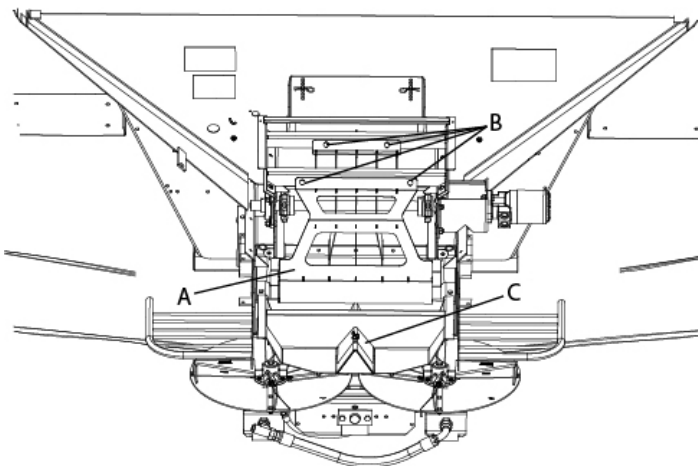

Figure 19A - MULTAPPLIER Hillside Divider (Style I)

Style I MultiApplier - Remove hardware from rear two chain shield holes on each side of MultiApplier and set aside. Install MultiApplier Hillside Divider (A) over conveyors and attach using chain shield hardware. Adjust Hillside Divider so that the middle divider is centered over both conveyors and the Material Divider (B) as shown in Figure 19A. Tighten hardware to recommended torque.

Figure 19B - MULTAPPLIER Hillside Divider (Style II)



Style II MultiApplier - Loosen hardware from rear two chain shield holes on each side of MultiApplier. Install MultiApplier Hillside Divider (A) and fasten to Support using single bin Hillside Divider hardware removed before MultiApplier installation (B). Adjust Hillside Divider so that the middle divider is centered over both conveyors and the Material Divider (C) as shown in Figure 19B. Tighten all hardware to recommended torque.

Micro Cover Installation

Air Supply and Electrical Requirements

Auxiliary Supply Line	Electrical Connections
Dry Air - 85 PSIG (5.86 Bar)	Red = 12 V (+) Black = Ground (-)

Refer to "MultiBin Lid Pneumatics" in the spreader parts manual for air line connections.

Make sure all hardware on insert is torqued before installing cover.



WARNING Pressurized air may cause sudden movement of parts. Do not service cover components until safety precautions have been performed. Take preventative measures to prevent falling or runaway of cylinder or mechanism before maintenance and restart of spreader. Exhaust all residual air and cut the pressure supply for components before servicing. Injury can occur if precautions are not taken.



WARNING Open cover lid with air prior to removing actuator pin and block cover lid to prevent closing. Unintentional closing could cause injury.

Fasten a three-point lifting device to two lift hooks and one hole in guide mount as shown in Figure 20. Hoist cover onto MULTI BIN as shown in Figure 21. Align slots and attach hardware. Tighten to recommended torque. Secure fittings and airline tubing on MULTI BIN with wire ties as shown in Figure 22. Connect to air and electrical systems. Open lid and install additional hardware inside cover. Install screens.

Refer to "Air Schematic" page in the Troubleshooting section for air supply requirements.

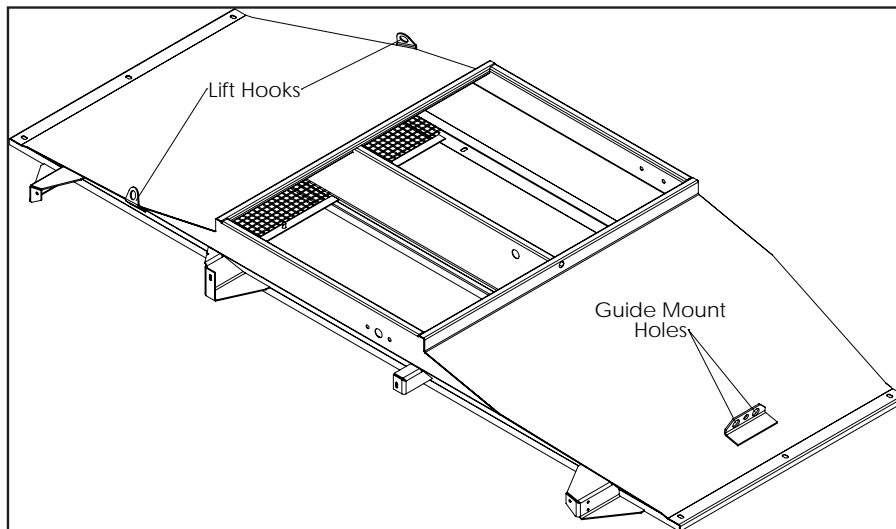

Figure 20 - Lift Hooks & Guide Mount

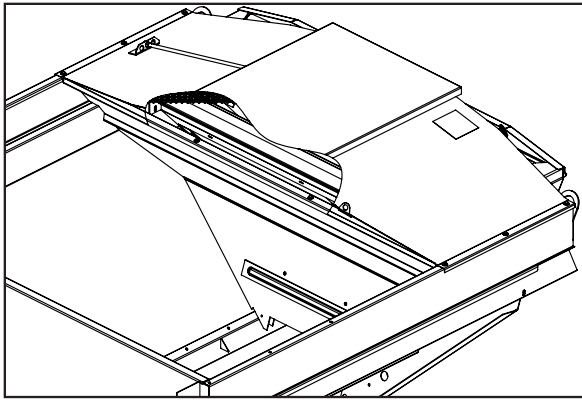

Figure 21 - Cover Placement

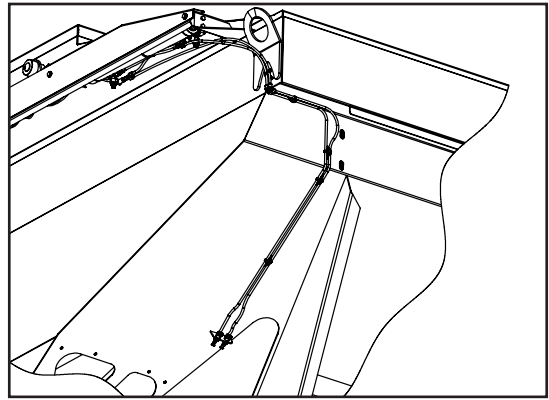

Figure 22 - Cover Airline Tubing

Electrical Connections

Connect all electrical control circuits. The supply conductor should be connected directly to the battery. All wiring should be approved automotive insulated wire, supported adequately with insulating ties or straps, and located where it will not interfere with any control or access. Make sure wiring does not contact any moving parts or sharp edges and is kept away from hydraulic lines and heated parts.

Insert Removal/Endgate Installation

Remove insert and reinstall endgate, Inverted "V", single conveyor Hillside Divider, etc. by following applicable installation instructions in reverse order. Make sure the insert hydraulics, electrical connections and air lines are disconnected from the spreader before removal. See "Inverted V" in spreader parts manual.

Hydraulics Removal

Route hydraulic hoses on the spreader and the insert as shown in Figures 23A - 23C as applicable.

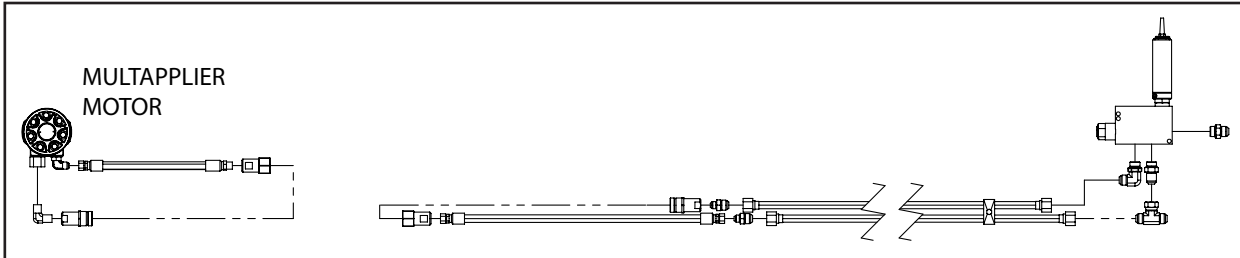

Figure 23A -Detach MULTAPPLIER

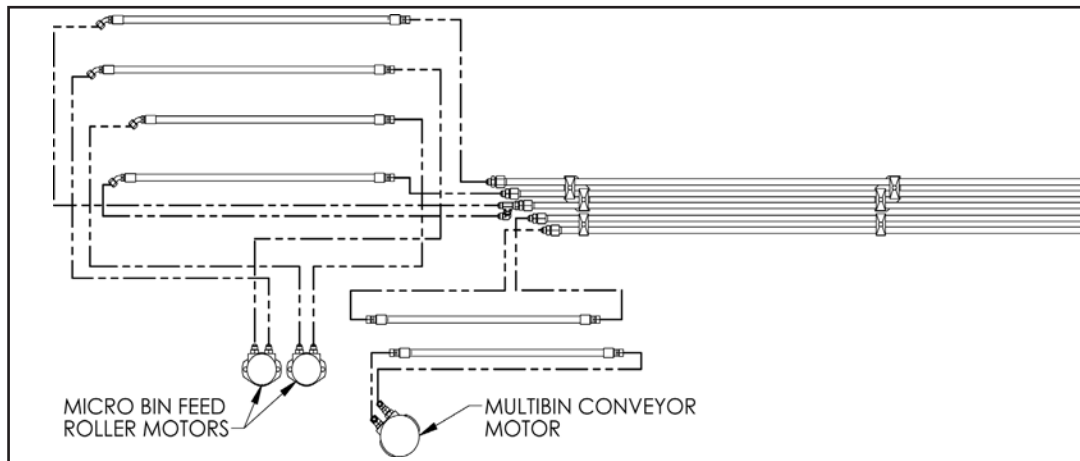

Figure 23B - Detach MULTIBIN Dual Micro

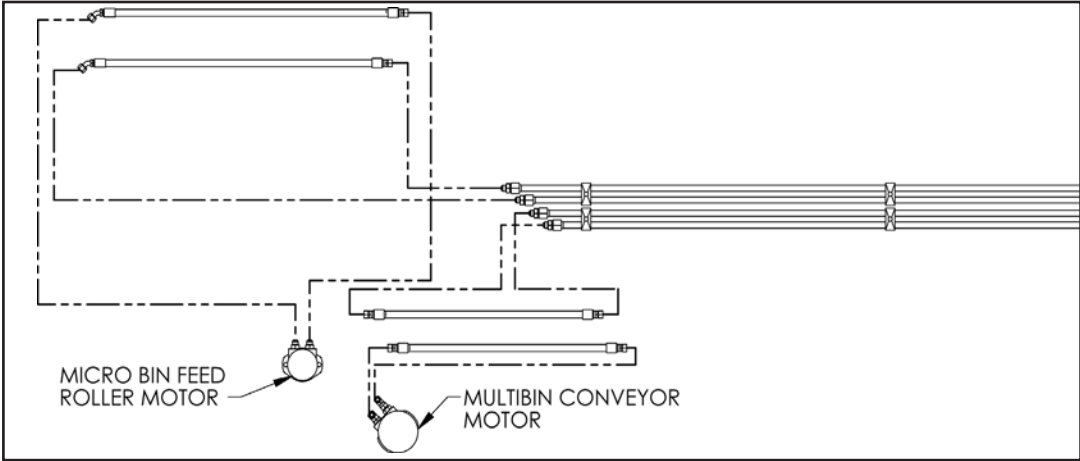

Figure 23C – Detach MULTIBIN Operation Single Micro

This page is intentionally left blank.

The L4000G4 is a hopper type spreader intended for spreading free flowing granular agricultural materials, such as chemical fertilizers, agricultural limestone, and gypsum. It is intended for agricultural vehicle mounting.

The unit is powered hydraulically and provides variable speed control for the spinner and full automatic ground speed control for the conveyor.

The conveyor delivers material to the spinners through an adjustable metering gate at the rear of the hopper body. Orbital type hydraulic motors mounted to 6 to 1 ratio spur gear case on the L4000G4 drive the conveyor. The conveyor options include a pintle type chain joined by cross bars every (#3) link or a belt-over-chain type having parallel strands of pintle type (#4) chain joined by cross bars every other link.

The spinner assembly has two 24-inch (610mm) diameter dished discs. Each disc has four formed and heat treated fins that are adjustable to radial angle. The spinner is fully adjustable by means of a rotating handle.

The optional 304 stainless steel hopper style spreader MultiApplier or MultiBin may be inserted in the main bin.

Inserting the MultiApplier allows for two materials to be spread simultaneously. It features a 24-inch (610mm) belt-over-chain type conveyor having parallel strands of pintle type (#4) chain joined by cross bars every other link. The direct driven conveyor is also controlled independently enabling the delivery of material at variable rates through the adjustable gate at the rear of the hopper body. The hillside divider improves material placement on the spinner for a more effective spread pattern.

Inserting the MultiBin will convert the spreader to a 3 or 4 hopper unit, which can be used independently or together for straight and variable rate applications. The front two hoppers dispense fertilizer products while the single or dual hopper at the rear dispense(s) micronutrients or seeding products. The rear bin(s) are sloped forward to improve chassis weight distribution. Material is delivered from the front bin by conveyor and from the rear bin(s) by passing through a meter wheel, material dividers and main spinner assembly with 24-inch (610mm) diameter dished discs. Bin sensors are installed to warn when materials are low in each micronutrient bin.

The MultiBin also comes equipped with an upper and lower material divider which improves material placement on the spinner for a more effective spread pattern.

An optional micronutrient stainless steel cover which opens and closes with a stainless steel air cylinder is available.

Screens installed on micronutrient bins keep large chunks of material out of the bins by breaking the material up as it enters the bins.

This product is intended for commercial use only.

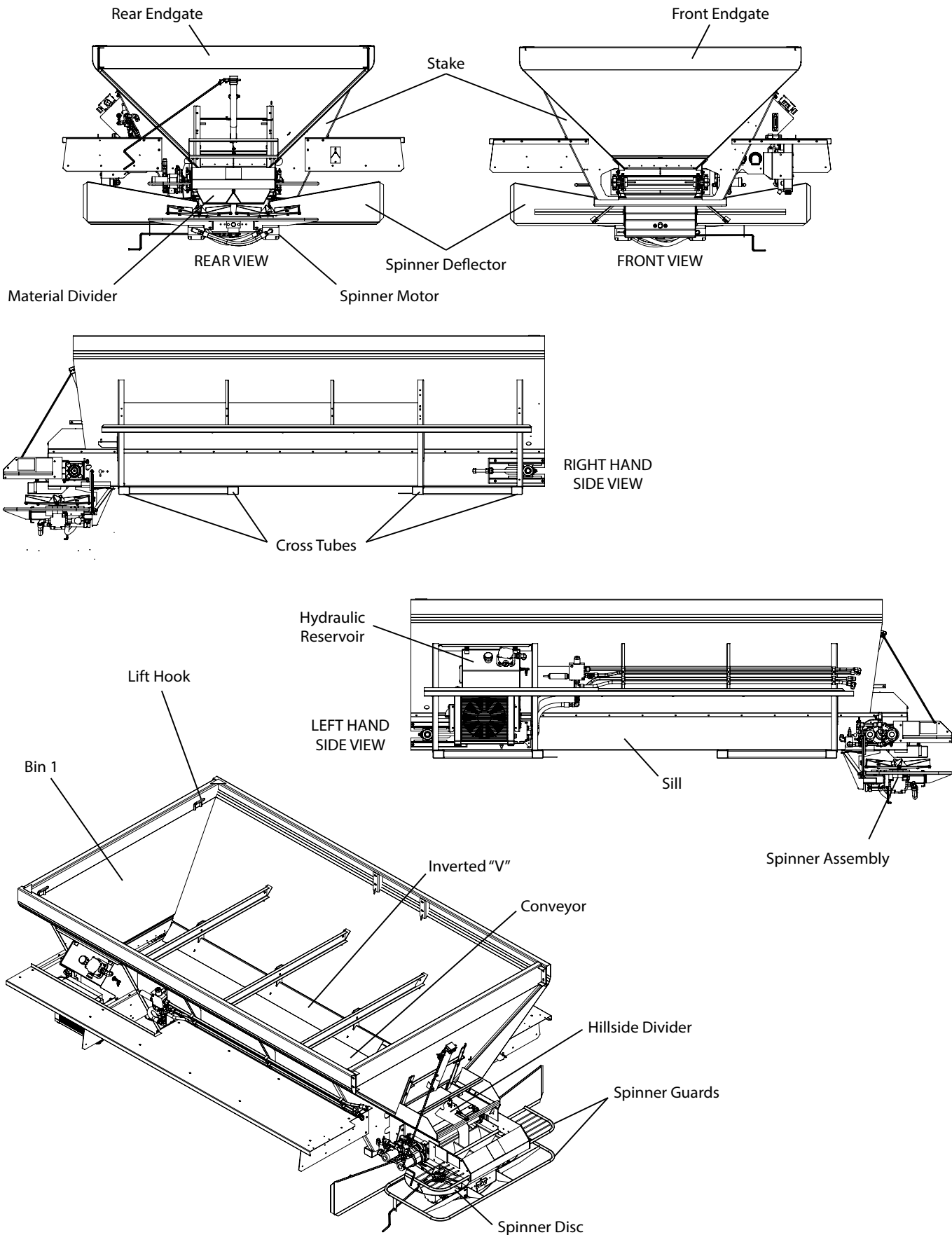

Stake: Side support for main hopper walls.

Rear Endgate: Welded or bolt-in endgate (depending on model) furthest from chassis cab (Rear based on direction of travel). Holds mounted Feedgate, allowing for rear release of material from bin.

Bin 1: Main holding bin for material or Insert. MultiApplier and MultiBin inserts (shown on following pages) are configured as Bins 2-4 depending on type used.

Feedgate: Adjustable gate mounted into Rear Endgate. Allows for variable rates of material flow by adjusting jack to desired height.

Conveyor: Conveys material to rear of unit.

Inverted "V": Mounted inside Main Hopper when Insert not installed. Distributes weight pressure across conveyor, allowing for consistent material flow to Feedgate, and promotes an improved blend when spreading fertilizer.

Material Divider: Ensures uniform spread pattern by directing material off of conveyor onto spinner discs.

Hillside Flow Divider: Ensures balanced flow of material across conveyor when on hillsides or uneven terrain.

Sill: Base of Main Hopper side walls. Contains Conveyor and supports machine walls.

Cross Tubes: Supports body, attaches to Chassis frame. Transfers weight from Main Hopper to Chassis.

Spinner Assembly: Contains adjustable G4 Spreader system, consisting of hydraulic spinners used for dispersal of various materials at different positioned settings allowing for consistent, even spread patterns across a wide variety of materials with a high rate of accuracy.

Spinner Guards: Upper and Lower guards, protects operators from spinner discs. Must be in place during any operation.

Spinner Deflectors: Deflect material away from machine.

Lift Hooks: Used to lift unit or insert with appropriately rated lifting device.

MULTAPPLIER

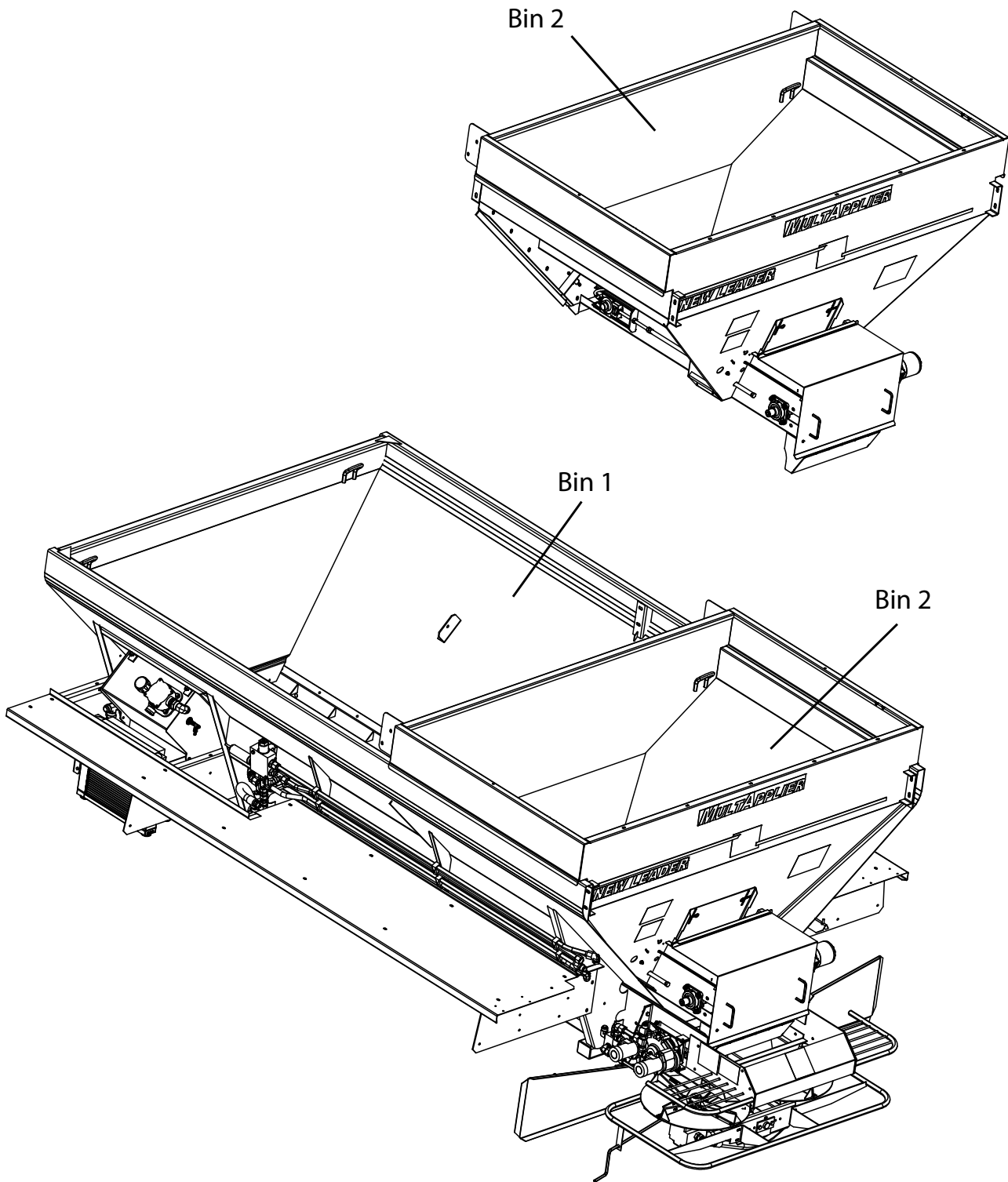

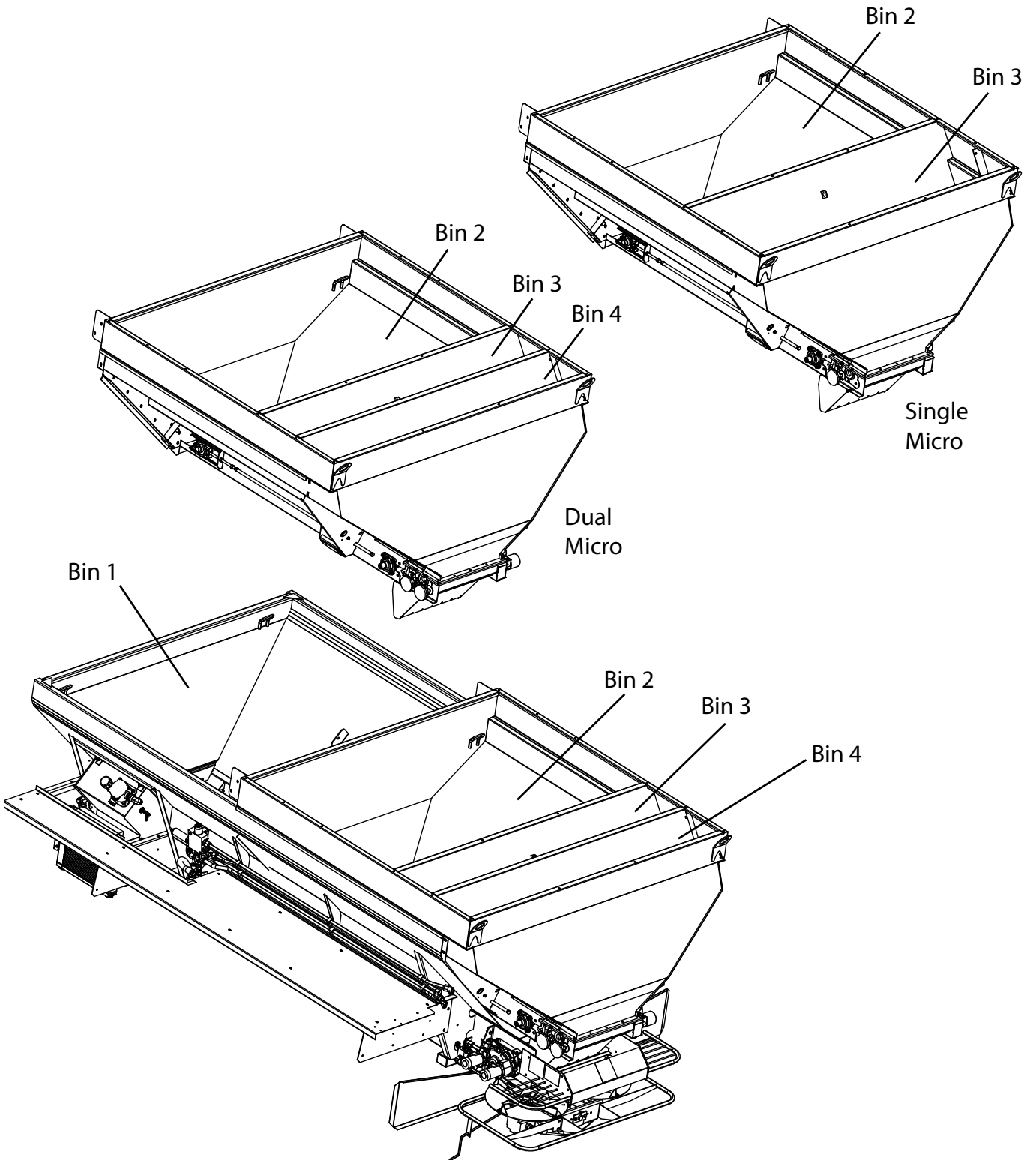

L4000G4, SINGLE BIN

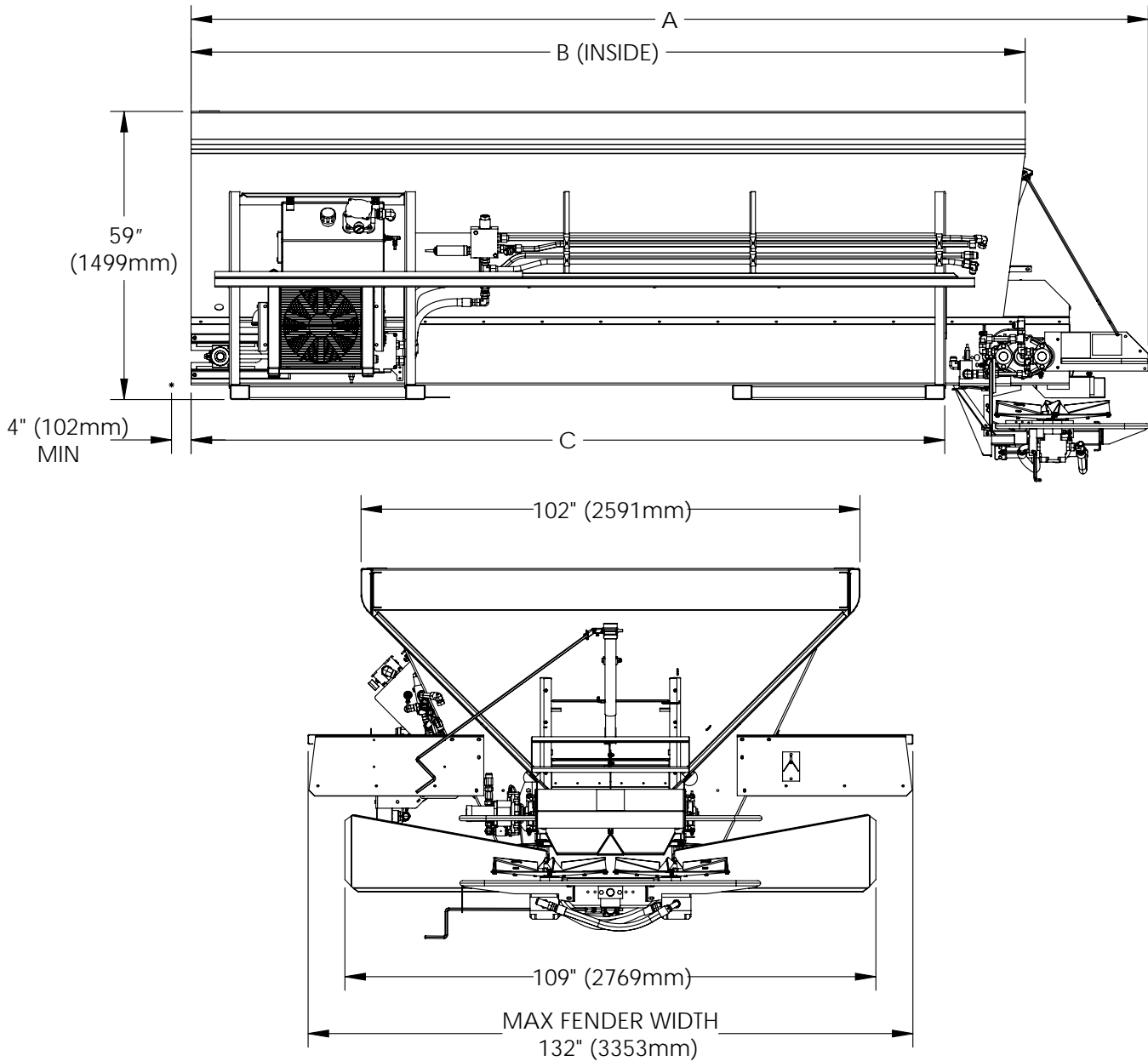

IMPORTANT!

Please consult federal, state, and local weight laws and chassis manufacturer's ratings to ensure neither government weight restrictions nor GVWR and GAWR's are exceeded. Tire and tandem axle size may require mounting modification of optional mud flaps.

L4000G4, SINGLE BIN WEIGHTS & CAPACITIES

Unit Length	Overall Length A	Inside Length B	Frame Length C	Approximate Weight Lbs (Kg)	Struck Capacity Cu Ft (Cu M)
13' (3.96m)	184" (4674mm)	156" (3962mm)	143" (3632mm)	3700 (1682)	278 (7.87)
14' (4.27m)	196" (4978cmm)	168" (4267mm)	155" (3937mm)	4000 (1819)	300 (8.50)

L4000G4 WITH MULTAPPLIER

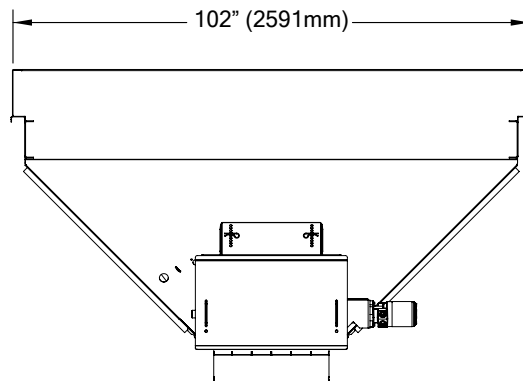
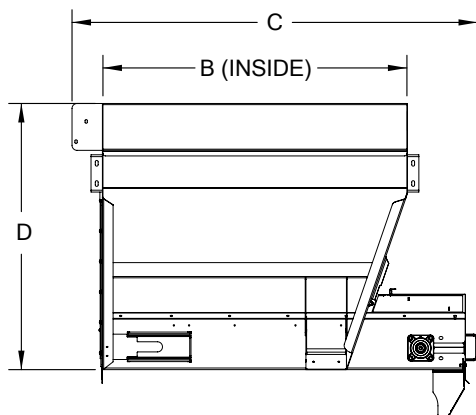
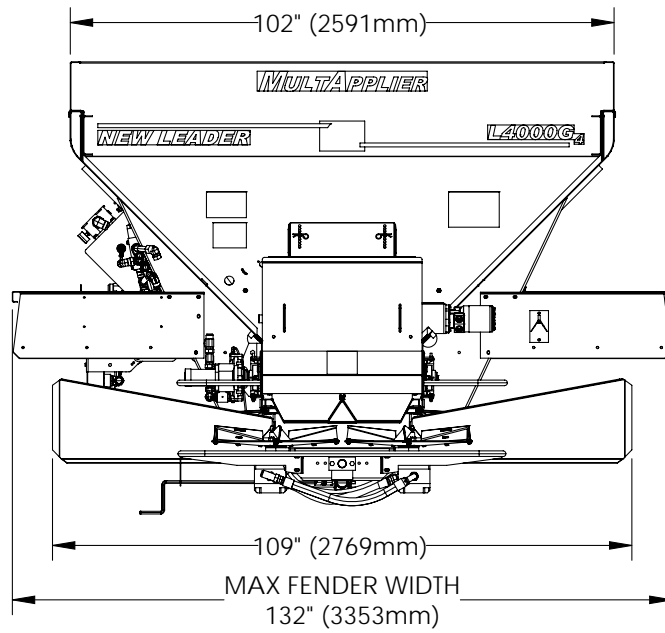
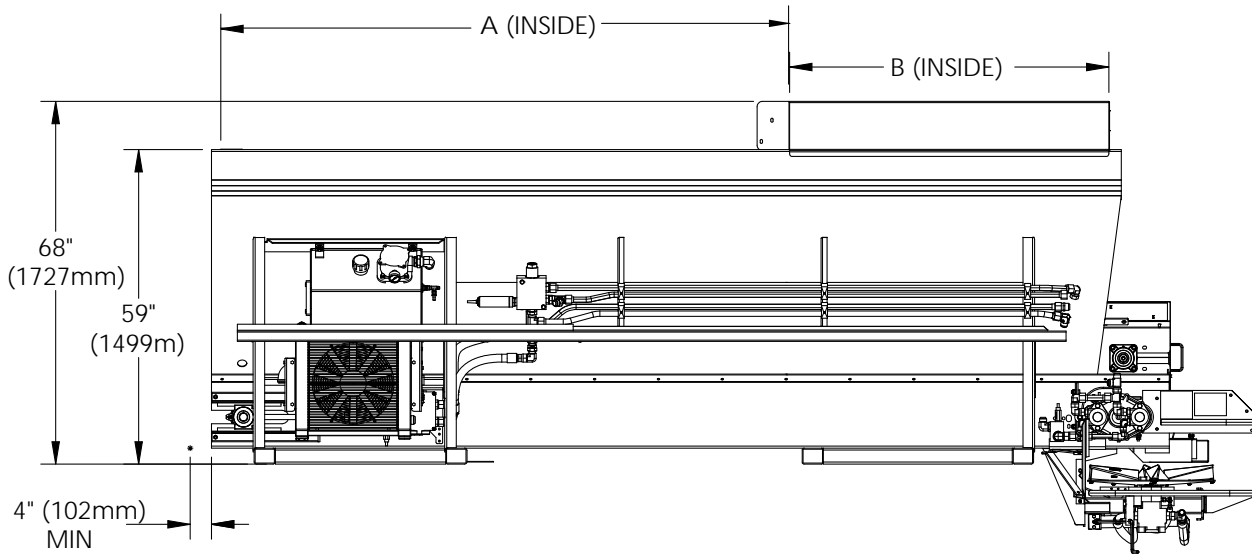

L4000G4 WITH MULTAPPLIER WEIGHTS & CAPACITIES

	With 5' MultApplier	With 5' * MultApplier	With 7' MultApplier	With 7' * MultApplier
Unit Length	Approximate Weight Lbs (Kg)	Struck Capacity Cu Ft (Cu M)	Approximate Weight Lbs (Kg)	Struck Capacity Cu Ft (Cu M)
13' (3.96m)	4400 (2000)	226 (6.40)	4600 (2091)	168 (4.76)
14' (4.27m)	4700 (2137)	255 (7.22)	4900 (2228)	197 (5.58)

STYLE I MULTAPPLIER ALONE DIMENSIONS & CAPACITIES

Insert Unit Length	Inside Length A	Inside Length B	Overall Length C	Height D	Approximate Weight Lbs (Kg)	Struck Capacity Cu Ft (Cu M)
5' (1.52m)	96" (2438mm)	60" (1524mm)	78" (1981mm)	54" (1372mm)	1000 (455)	115 (3.25)
7' (2.13m)	84" (2134mm)	84" (2134mm)	102" (2591mm)	54" (1372mm)	1200 (546)	161 (4.56)

STYLE II MULTAPPLIER ALONE DIMENSIONS & CAPACITIES

Insert Unit Length	Inside Length A	Inside Length B	Overall Length C	Height D	Approximate Weight Lbs (Kg)	Struck Capacity Cu Ft (Cu M)
5' (1.52m)	96" (2438mm)	60" (1524mm)	80" (2032mm)	53" (1346mm)	1100 (500)	115 (3.25)
7' (2.13m)	84" (2134mm)	84" (2134mm)	104" (2642mm)	53" (1346mm)	1300 (591.0)	161 (4.56)

* Struck Capacity Includes Sideboards

L4000G4 WITH MULTIBIN

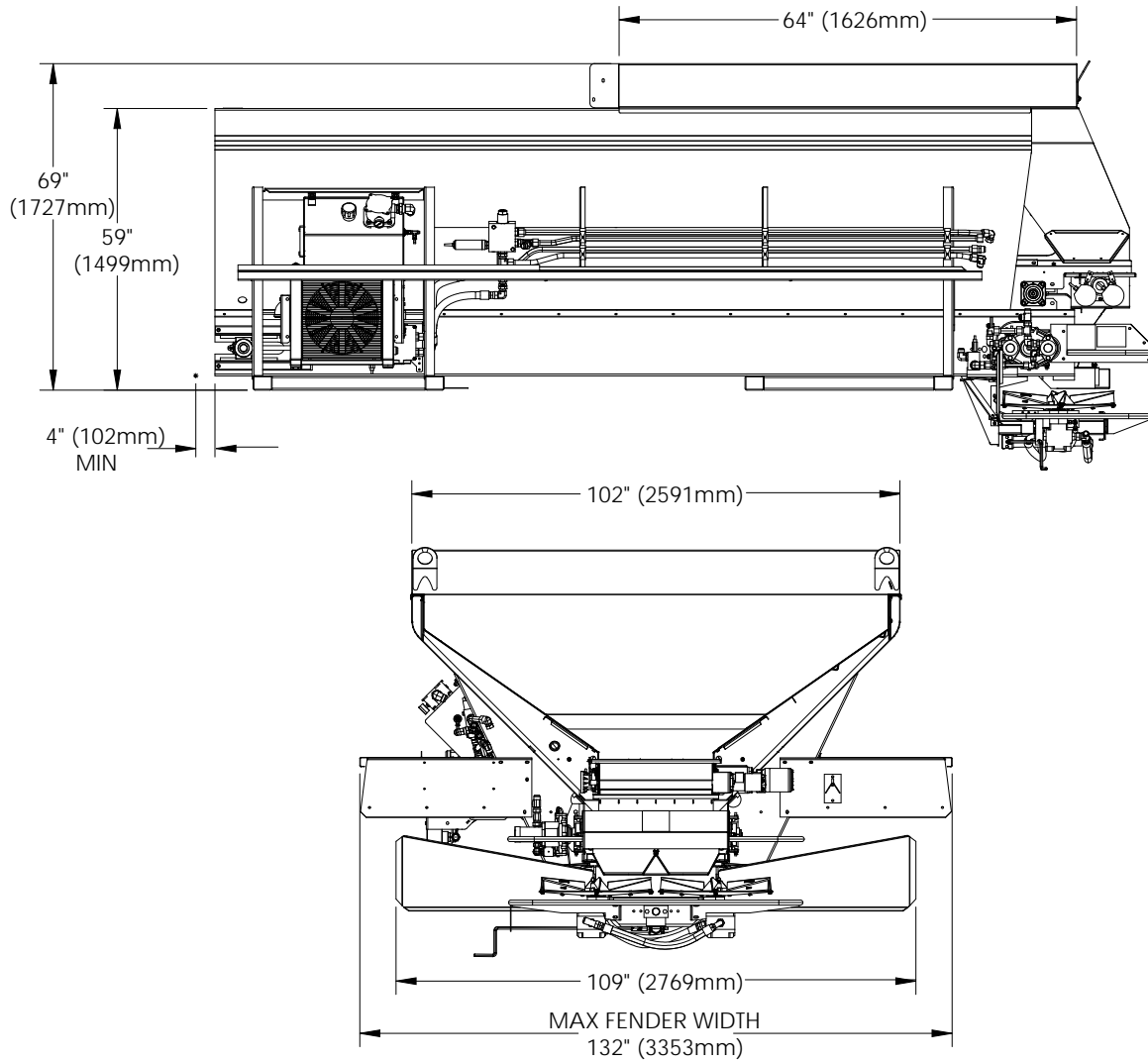

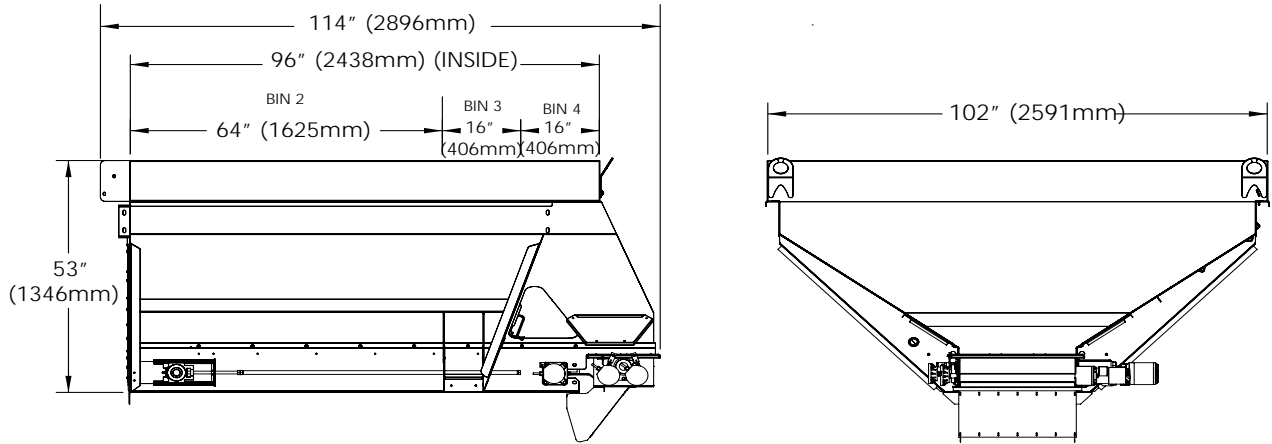

L4000G4 WITH MULTIBIN DIMENSIONS & CAPACITIES

Unit Length	Approximate Weight Lbs (Kg)	Struck Capacity * Cu Ft (Cu M)
13' (3.96m)	5000 (2273)	168 (4.76)
14' (4.27m)	5300 (2410)	197 (5.58)

MULTIBIN ALONE DIMENSIONS & CAPACITIES

	Inside Length	Approximate Weight Lbs (Kg)	Struck Capacity Cu Ft (Cu M)
MultiBin	96" (2438mm)	1700 (773)	
MultiBin (Bin 2)	64" (1626mm)		143 (4.05)
Single Micro (Bin 3)	32" (813mm)		44 (1.24)
Dual Micro (Bin 3)	16" (406mm)		23 (.65)
Dual Micro (Bin 4)	16" (406mm)		21 (.59)

* Struck Capacity Includes Sideboards



WARNING Stand clear of moving machinery.

NOTE: Do not load spreader with material.

1. Check entire unit to make sure all fasteners are in place and properly tightened per “Standard Torques” in this manual.
2. Make sure no other persons are in vicinity of spreader.
3. Make sure no loose parts are in unit or on conveyor or spinner.
4. Check oil level in hydraulic reservoir; fill as necessary. Refer to “Lubricant & Hydraulic Oil Specifications” in this manual for proper oil. Completely open reservoir valves.
5. Start engine and turn on hydraulics. Allow hydraulics to circulate until oil is warm.
6. Run spinner only at 300RPM. Allow to run until spinner is operating smoothly and all air has been purged from system.
7. Run conveyor at 20RPM and spinner at 300RPM. Run until conveyor is operating smoothly.
8. Run conveyor at 20RPM and spinner at 700RPM. Allow both conveyor and spinner to run until operating smoothly.
9. Run conveyor at 0RPM and spinner at 0RPM. Make sure both conveyor and spinner do not move.
10. Calibrate spreader as defined in the manual for the controller that is supplied with your machine.
11. Complete spread pattern test per “Spread Pattern Testing Procedures” in this manual.
12. Shut system down.



WARNING

DO NOT check leaks with hands while system is operating as high pressure oil leaks can be dangerous! If skin is pierced with hydraulic fluid at high pressure seek immediate medical attention as fluid injected into the skin could cause gangrene if left untreated. Relieve pressure before disconnecting hydraulic lines or working system. Make sure all hydraulic fluid connections are tight and all hydraulic hoses and lines are in good condition before applying pressure to the system. Wear protective gloves and safety glasses or goggles when working with hydraulic systems.



WARNING

DO NOT check for leaks adjacent to moving parts while system is operating as there may be danger of entanglement!

13. Check all connections in hydraulic system to make sure there are no leaks.
14. Check hydraulic oil reservoir and refill to maintain level at mid-point of gauge.

G4 Spinner Squaring

The squareness of the G4 Spinner Assembly and supporting parts plays a critical role in obtaining acceptable spread patterns. It is highly recommended that measurements are checked before spreading with a new unit, and any time after service or repair work has been performed on any part affecting spread patterns.

1. Figure 1 - Begin by ensuring that the Spinner Assembly is mounted correctly. The Spinner Frame should be sitting on top of/inside the Sill flanges, NOT hanging below.

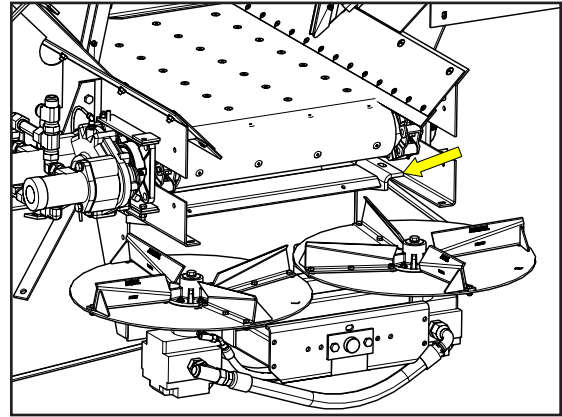

Figure 1

2. Figure 2 - Measure from the Spinner Frame mounting flange to the end of the Sill on each side. Measurement should be 9-7/8" (25cm). Measurements must be equal, or no greater than 1/8" (0.3cm) off overall.

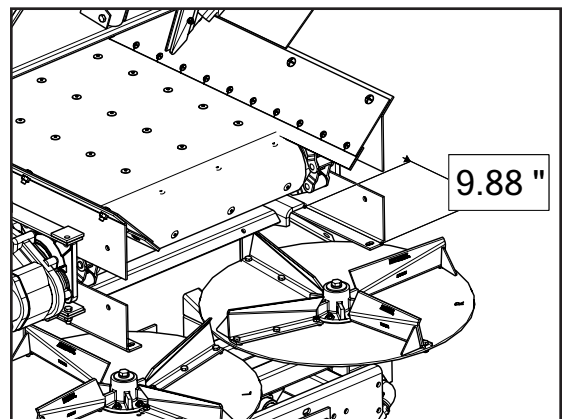

Figure 2

- Figure 3A - 3B - Check Spinner Assembly squareness by measuring from top edge of left hand Sill to inner hex flat on right hand Spinner Hub bolt. Repeat for opposite side.

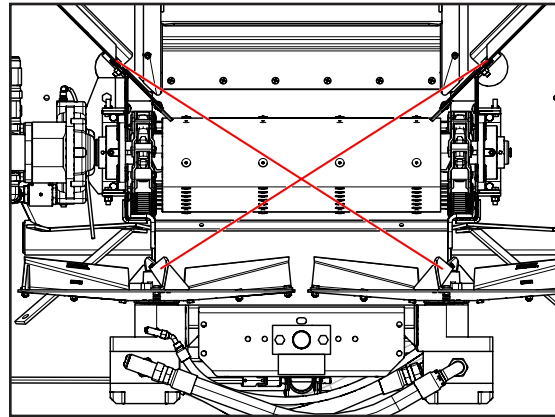

Figure 3A

- Measurements must be equal, or no greater than 1/8" off overall.

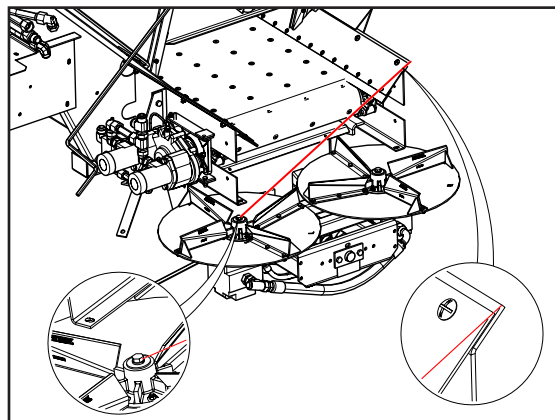

Figure 3B

- Figure 4 - If adjustments are necessary, loosen the four 1/2" carriage bolts and adjust assembly as necessary. Once corrected, tighten hardware to recommended torque. See "Standard Torques" for details.

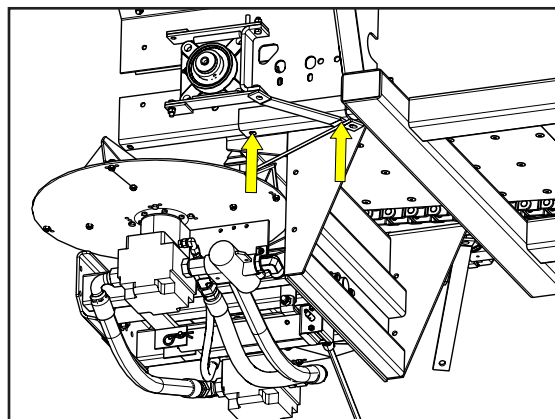

Figure 4

6. Figure 5 - Center Material Divider by measuring from the right hand inner drop-off point to the inner hex flat on the right hand Spinner Hub Bolt. Repeat measurement on opposite side. Measurements must be equal, or no greater than 1/8" off overall.

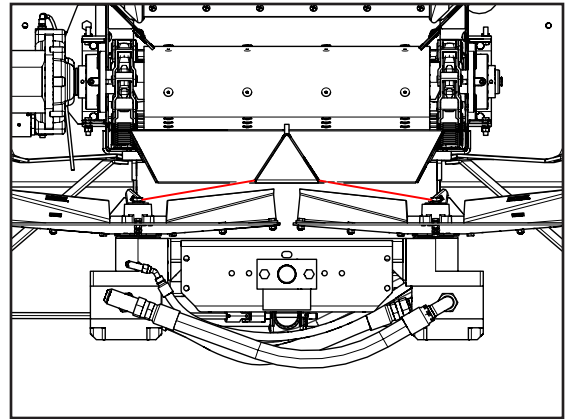

Figure 5

7. Figure 6 - Measure on each side from Spinner Frame back plate to forward drop-off point on Material Divider. Both measurements must be 12-1/4" (31cm) or no greater than 1/8" (0.3cm) off overall.
8. If adjustments are necessary, loosen the 3/8" capscrews on each side and adjust as necessary. Once corrected, tighten hardware to recommended torque.

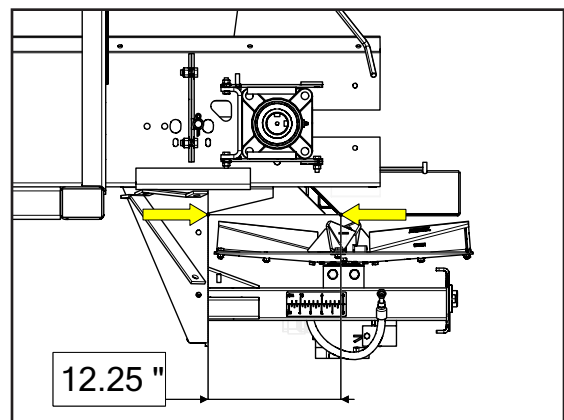

Figure 6

9. Figure 7 - If equipped, Ensure the Hillside Divider is mounted squarely and centered at both the front and the rear. Hillside Divider panel should be perpendicular to ground. Ensure the rear of the panel is centered over the center section of the Material Divider.

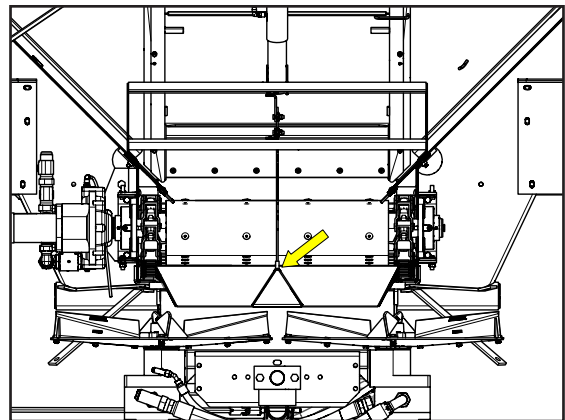

Figure 7

10. Figure 8 - Center the front of the Hillside Divider by measuring from the divider panel to the point of contact between the shield and the conveyor on each side. Measurements should be equal.

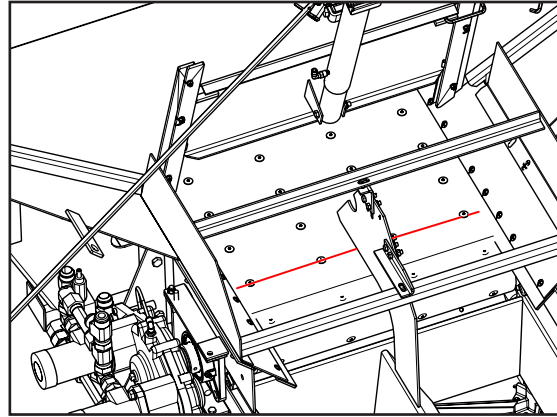

Figure 8

11. Figure 9 - Lastly, ensure that the Hillside Divider panel has proper clearance from the belt. The bottom edge of the divider panel should be approximately 3/8" (1cm) from the rubber belting of a #4 BOC.
12. If adjustments are necessary, loosen the hardware at the Hillside Divider panel as required and adjust as necessary. Once corrected, tighten hardware to proper torque.

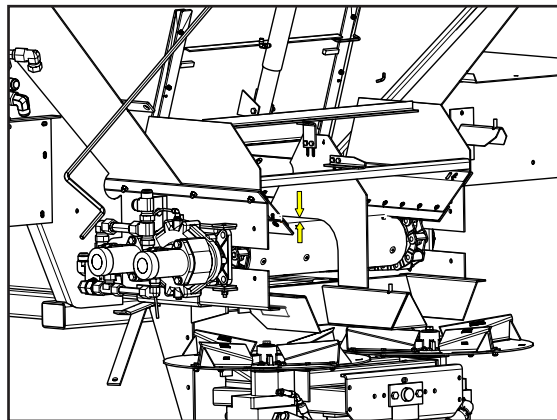

Figure 9

13. Figure 10 - Ensure all guards and shields are securely in place.
14. The spreader is now ready for field testing.

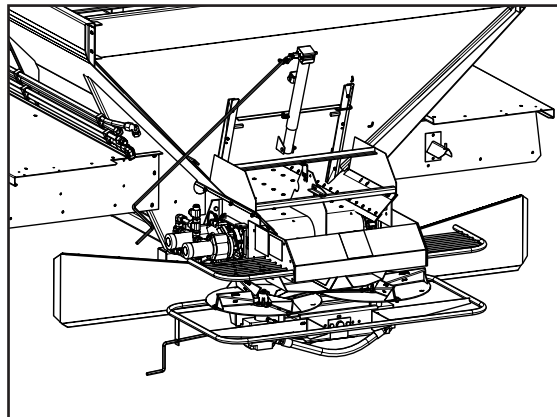

Figure 10

The following procedure is a guide:

NOTE: Do NOT fill spreader with material

1. Field test over any suitable course which allows vehicle to be driven at speeds to be used while spreading.
2. Ensure unit has been properly serviced, that the hydraulic reservoir is full and gate valve under reservoir is fully open. Do not load spreader.
3. Run spinners at 500 RPM.



DANGER

Take proper safety precautions when observing conveyor and spinner speed while vehicle is in motion! These may include use of suitable mirrors clamped to permit observation by a safely seated observer, following the spreader in another vehicle at a safe distance, or other suitable means. Do not stand on fenders, in body or on any part of spreader as there is danger of falling off the vehicle or into moving parts! Use great care in performing this test!

4. Start engine. Turn control to "on" position. Engage PTO and allow to run at fast idle long enough to bring hydraulic oil up to operating temperature. Spinners should revolve at moderate speed and the conveyor should not move.
5. Refer to controller's operation manual for conveyor operating instructions. Set program to operational mode and begin forward travel. Move conveyor switch to "on" position. Conveyor should start immediately when vehicle moves and should continue to run at speeds which should vary directly with the vehicle's ground speed; the conveyor should speed up as vehicle speed increases and slow down as vehicle speed reduces. Spinner speed should remain constant when engine speed is above minimum operating range.

1. Make sure unit has been properly serviced and is in good operating condition. It is highly recommended to run the spreader prior to loading material to ensure acceptable operation.
2. Program controller with correct data for material(s) and application.
3. Adjust feedgate to appropriate setting.
4. Adjust spinner to give spread pattern desired. Calibrate and spread pattern test for any new material.
5. Fill applicable bins with material to be spread.
6. Engage hydraulics.
7. Begin spreading.



CAUTION Drive only at speeds which permit secure control of vehicle.

NOTICE!

CHANGE HYDRAULIC OIL FILTER AFTER FIRST WEEK (OR NOT MORE THAN 50 HOURS) OF OPERATION ON A UNIT.

*Visit www.newleadervip.com for interactive tools to calculate yield, proper feedgate opening, conveyor revolutions per minute and mph to maximize the performance of your spreader.

Preventative Maintenance Pays!

The handling and spreading of commercial fertilizers is a most severe operation with respect to metal corrosion. Establish a frequent, periodic preventative maintenance program to prevent rapid deterioration to spreading equipment. Proper cleaning, lubrication and maintenance will yield longer life, more satisfactory service and more economical use of your equipment.

**WARNING**

Shut off all power and allow all moving parts to come to rest before performing any maintenance operation.

Hydraulic System

Proper oil in the hydraulic system is one of the most important factors for satisfactory operation. Utmost cleanliness in handling the oil cannot be stressed enough. Keep hydraulic oil in original closed containers, clean top of container before opening and pouring, and handle in extremely clean measures and funnels.

Refer to "Lubricant and Hydraulic Oil Specifications" for selection of the proper hydraulic fluid for use in the hydraulic system.

Service Schedule

**WARNING**

DO NOT check leaks with hands while system is operating as high pressure oil leaks can be dangerous! If skin is pierced with hydraulic fluid at high pressure seek immediate medical attention as fluid injected into the skin could cause gangrene if left untreated. Relieve pressure before disconnecting hydraulic lines or working system. Make sure all hydraulic fluid connections are tight and all hydraulic hoses and lines are in good condition before applying pressure to the system. Wear protective gloves and safety glasses or goggles when working with hydraulic systems.

**WARNING**

DO NOT check for leaks adjacent to moving parts while system is operating as there may be danger of entanglement!

Check hydraulic oil daily by means of sight gauge on reservoir. Add oil as necessary to maintain level around mid-point of sight gauge. Periodically inspect hoses and fittings for leaks.

NOTICE!

Change hydraulic oil filter after first week (or not more than 50 hours) of operation on a unit.

After first filter change, replace filter when indicator reaches Red Zone.

Drain reservoir through drain plug (not through suction outlet), flush, and refill and change filter element annually. Oil and filter should also be changed whenever oil shows any signs of breaking down under continued high-pressure operation. Discoloration of oil is one sign of breakdown.

Conveyor Gearcase

Drain oil in a new unit after first two weeks (or not more than 100 hours) of operation, and flush gear case thoroughly with light oil. Refer to "Lubricant and Hydraulic Oil Specifications" section for proper grade oil and recommended amounts of lubricant. After initial change, oil should be changed every 2,000 hours of operation or annually, whichever occurs first. Check gearcase oil level monthly.

Check gearcase oil level monthly.

Hydraulic Hose

Hose assemblies in operation should be inspected frequently for leakage, kinking, abrasion, corrosion or other signs of wear or damage. Worn or damaged hose assemblies should be replaced immediately.



WARNING

Testing should be conducted in approved test stands with adequate guards to protect the operator.

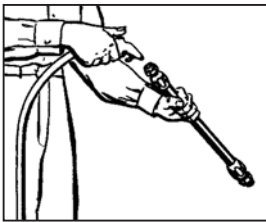

Clean

Clean assembly by blowing out with clean compressed air. Assemblies may be rinsed out with mineral spirits if the tube stock is compatible with oil, otherwise hot water at 150°F (65.55° C) maximum may be used.



Inspect

Examine hose assembly internally for cut or bulged tube, obstructions, and cleanliness. For segment style fittings, be sure that the hose butts up against the nipple shoulder; band and retaining ring are properly set and tight, and segments are properly spaced. Check for proper gap between nut and socket or hex and socket. Nuts should swivel freely. Check the layline of the hose to be sure the assembly is not twisted. Cap the ends of the hose with plastic covers to keep clean.

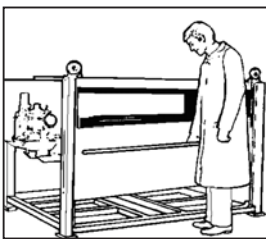

Test

The hose assembly should be hydrostatically tested at twice the recommended working pressure of the hose.

Test pressure should be held for not more than one minute and not less than 30 seconds. When test pressure is reached, visually inspect hose assembly for: 1. Any leaks or signs of weakness. 2. Any movement of the hose fitting in relation to the hose. Any of these defects are cause for rejection.

Storage and Handling

Hose should be stored in a dark, dry atmosphere away from electrical equipment, and the temperature should not exceed 90° F (32° C).

Conveyor Chain



WARNING

Stay out of the hopper body. If it's necessary to enter the hopper, return to the shop, empty body, turn off all power, set vehicle brakes, lock engine starting switch and remove keys before entering. Tag all controls to prohibit operation. Tags should be placed, and later removed, only by person working in the body.

Hose down unit and remove any material build-up on sprockets and under chain.

NOTICE!

The conveyor will move away from the bottom panel if material accumulates under the conveyor or on the sprockets. The more material that accumulates, the closer the chain will come to the chain shields. If the conveyor should catch a chain shield, it could permanently damage the conveyor, the chain shields or the unit. Do not remove material while conveyor or spinner is running!

Lubrication

Make sure unit is clean and completely dry. Lubricate conveyor chain at the end of each day of usage using a mixture of 75% diesel fuel and 25% SAE 10 oil. Shut down spinner and run conveyor at 20 RPM for two full revolutions to lubricate chain. After each unit washing, allow to dry, then lubricate.

Lubricate MULTAPPLIER/MULTIBIN conveyor chain bi-weekly and at end of each season with Fluid Film™ or equivalent. Shut down spinner and run conveyor at 20 RPM. Lubricate chain through two full revolutions. After each unit washing, allow to dry, then lubricate.

Before filling the unit with spreading material, activate the controller or power switch to run the pump oiler. Bleed all air from the lines and adjust the two spray nozzles so that the oil mixture sprays vertical onto the sprockets and chain.

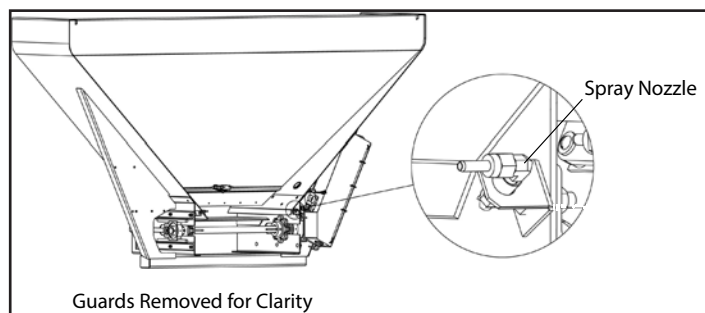

Figure 1 - Spray Nozzle

Tension

Proper chain tension is also a factor in chain and sprocket life. Measure from rear of main unit forward to achieve proper chain tension (Figure 2). Make sure chain is tensioned equally on both sides. This adjustment is made on each side of the unit at the front idler bearings.

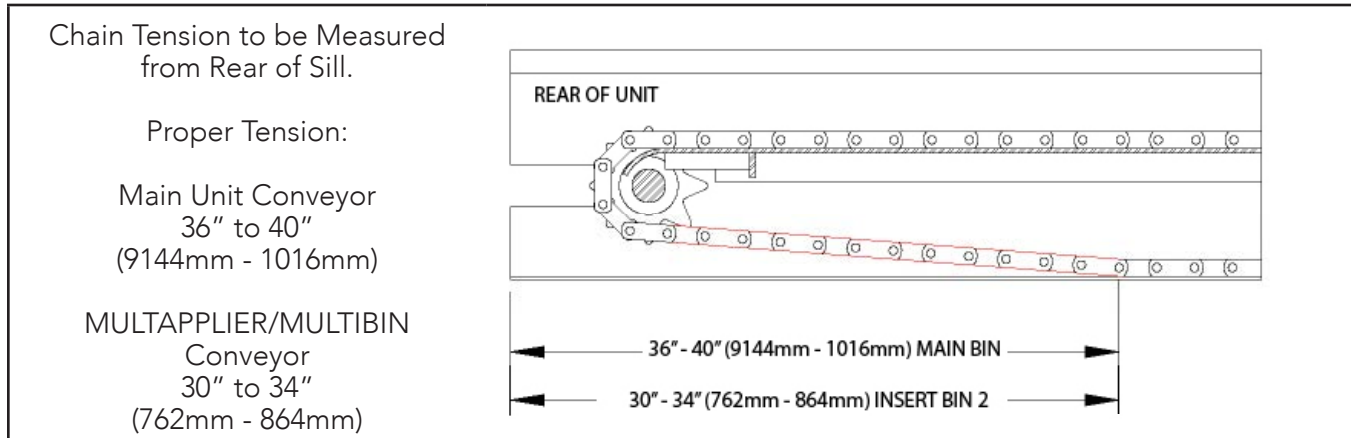

Figure 2 - Chain Tension

Conveyor chains that are too tight will tend to stretch, causing excess sprocket wear and eventually breakage. Excess slack presents the possibility of chain catching on sub-frame parts. Bent or distorted chain bars will cause damage to unit as well as fertilizer leakage with #3 conveyors. Straighten or replace bent or distorted chain bars immediately.

#4 BOC Conveyor Belt Maintenance

Standard belting for the #4 conveyor is moderately oil resistant (MOR) that is impervious to moisture, weathering, and normal action which can be used with chemical-impregnated fertilizer or oil-based additives.

- Inspect belt fastener occasionally for wear or "raveling" of belt grip area.
- Make sure belt connecting pin is positioned correctly as shown in Figure 3.

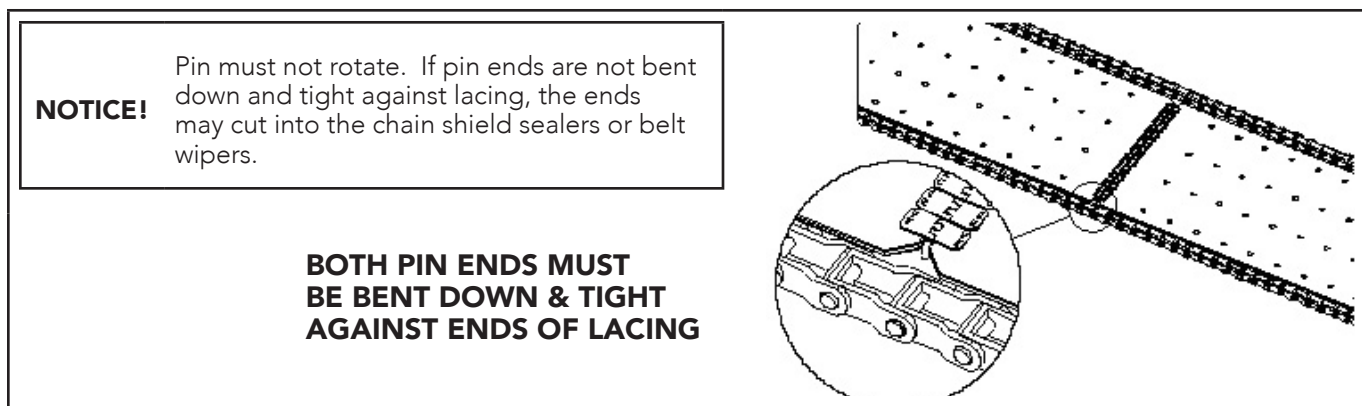

Figure 3 - Conveyor Belt Connecting Pin Installation

Bin Sensor

**WARNING**

Stay out of the spreader. Do not climb on spreader. Use a portable ladder to inspect, clean and maintain the bin sensor from outside the spreader. Failure to do so could result in injury from falling.

NOTICE!

Wipe sensor clean periodically to prevent accumulation of product. Avoid wet material as it may stick to sensor. If material sticks to sensor it won't warn user when bin is low.

Clean sensor with long handled brush or hose from outside of spreader. Do not aim high pressure sprayer directly at sensor—it could damage the components.

Lubrication of Bearings

Grease in a bearing acts to prevent excessive wear of parts, protects ball races, and balls from corrosion and aids in preventing excessive heat within the bearing. It is very important the grease maintain its proper consistency during operation. It must not be fluid and it must not channel.

Make sure all fittings are thoroughly cleaned before grease is injected. Points to be lubricated by means of a grease gun have standard grease fittings.

Lubricate bearings by pumping grease slowly until it forms a slight bead around the seals. This bead indicates adequate lubrication and also provides additional protection against the entrance of dirt.

Fasteners

Tighten all screws fasteners to recommended torques after first week of operation and annually thereafter. If loose fasteners are found at anytime, tighten to recommended torque. Replace any lost or damaged fasteners or other parts immediately. Check body mounting hardware every week.

Clean-Up

NOTICE!

High pressure wash can inject water and/or fertilizer into control components, causing damage. Use caution when cleaning these areas.

Thoroughly wash unit every two to three days during the operating season to maintain minimal maintenance operation. Hose unit down under pressure to free all sticky and frozen material.

It is important the unit be thoroughly cleaned at the end of each operating season. All lubrication and maintenance instructions should be closely followed. Repaint worn spots to prevent formation of rust.

MULTIBIN Meter Wheel(s): Pull inspection plug on right hand side of micro assembly. Blow out with compressed air.

Spinner Fins

Visually inspect spinner fins daily for build-up of material and wear. Spinner discs and fins must be kept clean and polished. Even a small build-up of material on a spinner can significantly affect the spread pattern. Rough, bent or worn fins will produce poor spread patterns. Replace worn fins and discs as needed. See Fin Kit Installation Instructions for replacement part numbers and instructions.

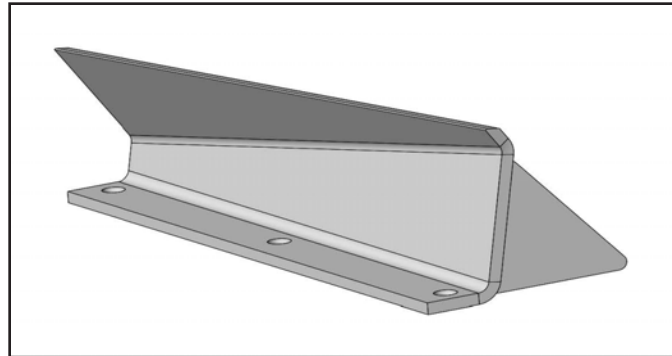

Figure 4 - Spinner Fin

Spinner Deflectors

Visually inspect spinner deflectors daily for build-up of material and damage. Clean as needed. Even a small build-up of material on a spinner deflector can affect the spread pattern. If damaged, bent or otherwise, replace. See parts manual for replacement part numbers.

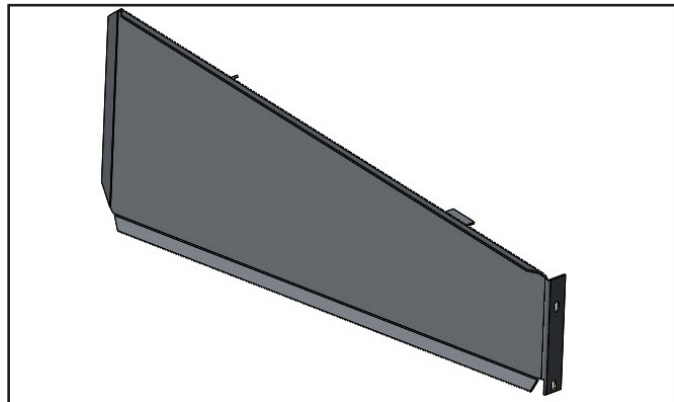

Figure 5 - Spinner Deflector

Material & Hillside Flow Dividers

Visually inspect material divider and hillside flow dividers (as equipped) daily for build-up of material and wear. Any build-up of material on divider components can affect performance. Clean as needed. Replace worn or damaged parts as necessary. See parts manual for replacement part numbers.

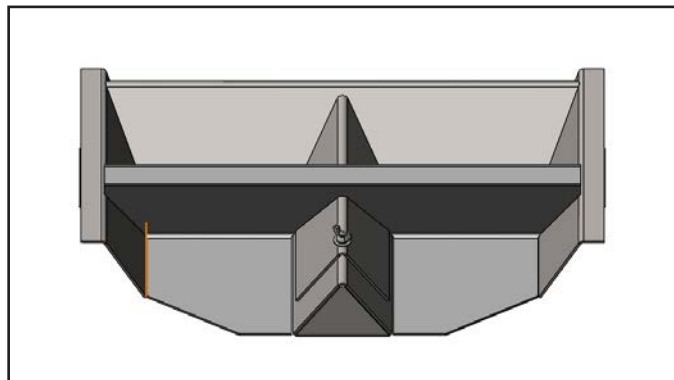

Figure 6 - Material Divider

Hydraulic System

Use premium quality lubricants with 100-200 SUS or 20-43 cSt viscosity at operating temperatures. The hydraulic fluid's specifications in the table below are for normal operating conditions. Extreme environments or dirty conditions may require the use of different oils. Consult your New Leader dealer or the Product Support Department at Highway Equipment Company for systems operating outside normal conditions.

Ideal Oil Operating Temperature	115-158°F (46.11-70° C)
Recommended Premium Lubricant	Multi-Purpose Agriculture Hydraulic & Transmission Oil
Lubricant Specifications Viscosity Index Viscosity at 40°C, cst Viscosity at 100°C, cst	Greater than 130 Less than 68 Greater than 9
Acceptable Fluid Example	Mobil 424

Gearcase Lubricant

Lubricate these assemblies with non-corrosive type extreme pressure (E.P.) gear oil conforming to MIL-L2105 B multi-purpose gear lubricating oil requirements (API Service GL 4) based on ambient temperatures listed below. Refill gear case with one and a half (1-1/2) pints (.70 liters) of recommended lubricant.

Ambient Temperature	Below 40° (4.44° C)	Between 40° (4.44°C) and 100° (37.77°C)	Above 100° (37.77°C)
Oil Type	SAE 80 E.P.	SAE 90 E.P.	SAE 140 E.P.

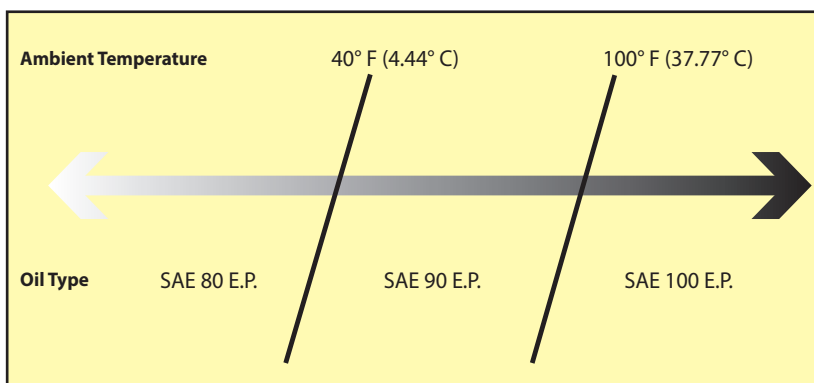

Grease Gun Lubricant

Use a waterproof ball and roller bearing lithium base lubricant with a minimum melting point of 300°F (148.8° C). This lubricant should have a viscosity which assures easy handling in the pressure gun at prevailing atmospheric temperatures. The grease should conform to NLGI No. 2 consistency.

Chain Conveyors

Use a mixture of 75% No. 1 or No. 2 diesel fuel or kerosene mixed with 25% SAE 10 engine oil in the main unit conveyor chain oiler.

Spray MULTAPPLIER/MULTIBIN conveyor chain with Fluid Film™ spray lubricant or equivalent.



WARNING Shut off all power and allow all moving parts to come to rest before performing any maintenance operation.

The spreader should be regularly lubricated with the lubricants recommended in this manual in accordance with the following chart:

Location	Places	Method	Frequency
Hydraulic System			
Reservoir	1		Check Daily. Change Annually
Filter	1	Check daily; Change when indicated (Red)	
Conveyor			
Dragshaft Bearings (A)	2	Grease Gun	Weekly
Idler Shaft Bearings (B)	2	Grease Gun	Weekly
Take-Up Screws (C)	2	Hand Grease	Weekly
Snubber Pulley Bearings (D)	2	Grease Gun	Weekly
Gearcase	1	Gear Oil	Check Monthly; Change Annually
Feedgate			
Jack Assembly (E)	1	Grease Gun	Annually
Spinner Assembly			
Jack Assembly (F)	1	Grease Gun	Weekly
Bin 2 Conveyor			
Dragshaft Bearings (G)	2	Grease Gun	Weekly
Idler Shaft Bearings (H)	2	Grease Gun	Weekly
Take-Up Screws (J)	2	Hand Grease	Annually
Conveyor Chain Strands	2	Oil Mixture	Bi-Weekly
		Spray Lubricant	Annually

NOTE: Unusual conditions, such as excessive dust, temperature extremes or excessive moisture may require more frequent lubrication of specific parts.

*See "Lubricant and Hydraulic Oil Specifications" for types of lubricants and oil to be used.

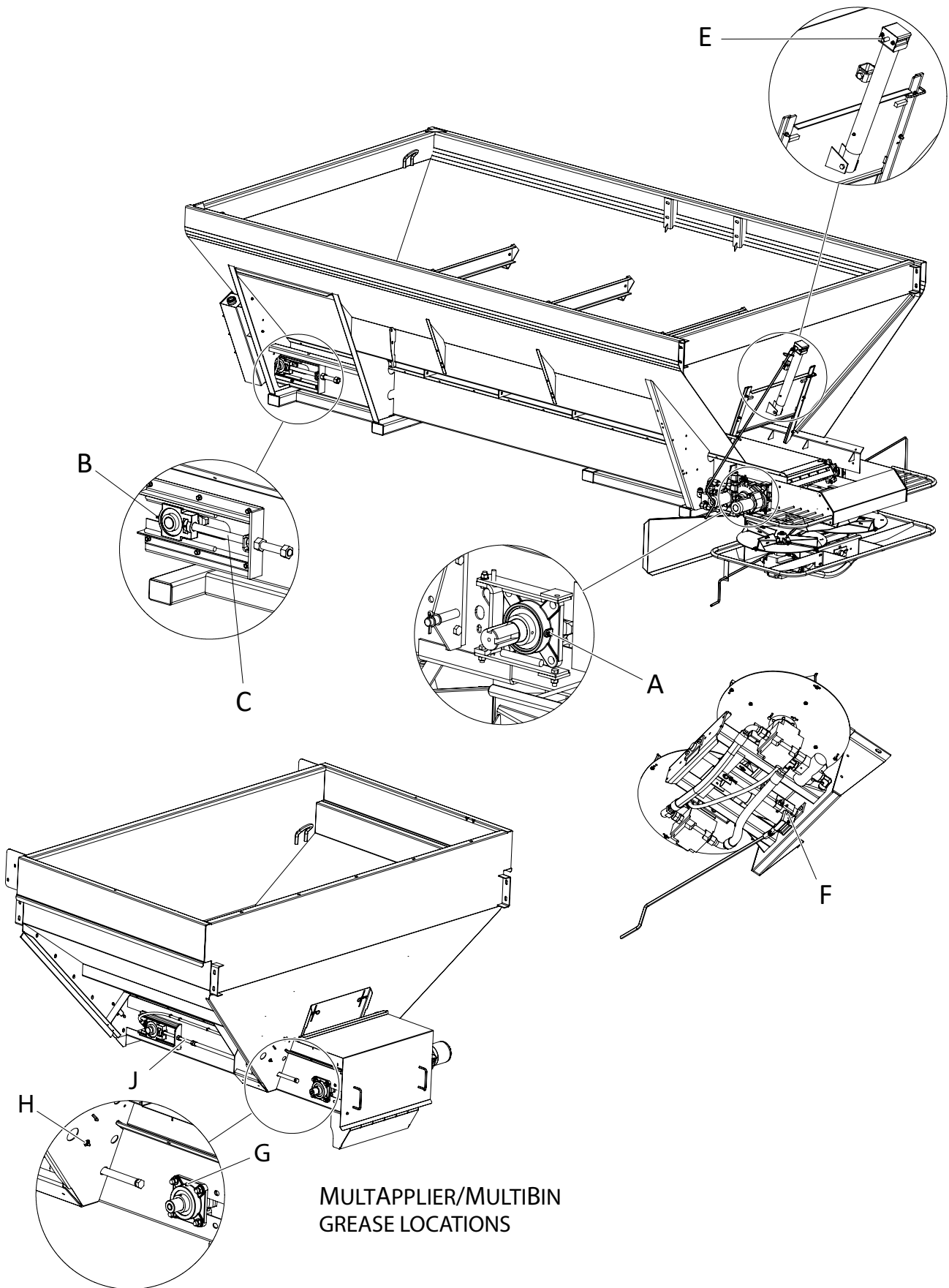

Symptom:	Reason:	Correction:
Spinner will not run	Defective Spinner Control Valve	Replace spinner control valve cartridge and coil.
	No voltage at valve	Verify spinner switch is on.
		Verify spinner enable is checked.
		Verify controller has a target spinner RPM entered.
		Check WSM 7.5 amp fuse is not blown.
		Verify spinner control harness is not damaged.
	Verify system was configured as Basic independent.	
	No hydraulic flow	Verify hydraulics are on.
Pressure test pump - replace as needed.		
System is going over relief - test & replace as needed.		
Spinner will not shut off	Defective spinner control valve	Replace spinner control valve cartridge.
	Control valve is manually overrode	Loosen jam nut on control valve cartridge and back set screw out until spinner stops.
Spinner runs erratic	Defective spinner control valve	Replace spinner control valve cartridge.
	Spinner speed sensor harness failure	Replace sensor harness.
	Spinner speed sensor not properly installed	Adjust sensor so that gap between sensor and fin mounting bolt is less than 1/8".
Spinner speed drops off when turning around	Improper control settings	Verify PWM control is set properly (HOLD for gear pumps, CONTROL for variable displacement).
Not applying correct rate	Incorrect settings	Verify density, swath width, gate opening, encoder pulses, and CFR number are all adjusted as needed.
No ground speed	Manual speed is enabled, but set to 0	Enter correct speed or disable manual speed
	AUX broadcast speed is enabled but radar not installed	Disable broadcast AUX speed.
	Incorrect speed source is selected	Select correct speed source.
Spinner speed does not hit target	Defective spinner control valve	Replace spinner control valve cartridge.
	Pump failure	Flow and pressure test pump.
	Spinner speed sensor not properly installed	Adjust sensor so that gap between sensor and fin mounting bolt is less than 1/8".
	Hydraulic flow dropping off	Adjust settings and speed. Pressure test relief (adjust or replace as needed).
	Spinner speed sensor harness failure	Replace sensor harness.
	Spinner speed sensor failure	Replace spinner speed sensor.

Symptom:	Reason:	Correction:
Conveyor will not run	Defective conveyor control valve	Replace conveyor valve cartridge.
	No voltage at valve	Verify bin switch and master switches on.
		Verify in controller that target rate, density, ground speed and a CFR number are all entered.
		Check WSM 7.5 amp fuse is not blown.
		Verify conveyor control harness is not damaged.
	No hydraulic flow	Verify hydraulics are on.
		Pressure test pump - replace as needed.
		System is going over relief - test & replace as needed.
Conveyor is going over relief - test & replace as needed.		
Conveyor will not shut off	Defective conveyor cartridge	Replace conveyor control valve cartridge.
	Control valve is out of time	Adjust cartridge timing.
Conveyor runs erratic	Defective conveyor cartridge	Replace conveyor control valve cartridge.
	Encoder failure	Replace encoder.
	Encoder harness failure	Replace harness.
	Rates smoothing is disabled	Enable rate smoothing.
Bin will not hit target rate	Defective conveyor cartridge	Replace conveyor control valve cartridge.
	Pump failure	Flow and pressure test pump.
	Going over relief	Adjust setting and speed. Pressure test relief (adjust or replace as needed).
	Encoder failure	Replace encoder.
	Encoder harness failure	Replace harness.
Hydraulics over-heating	Pump failure	Flow and pressure test pump.
	Too much flow	Flow test pump.
	System relief	Pressure test relief (adjust or replace as needed). Adjust settings and speed.
	Conveyor valve relief	Pressure test relief (adjust or replace as needed). Adjust settings and speed.
	Oil cooler fan failure	see oil cooler fan failures.
	Case drain is plugged.	Case drain requires zero pressure line back to tank.
Oil cooler fan failure	No power at fan	Verify FAN 30-amp fuse is not blown. Verify relay is working properly.
	Fan failure	Replace fan.
Bin level sensors not working properly	Not enabled	Verify system was configured with bin level sensors.
	Bin level sensor failure	Replace sensor.
	Bin level sensor harness failure	Replace harness.

MultiBin Cover Air Schematic

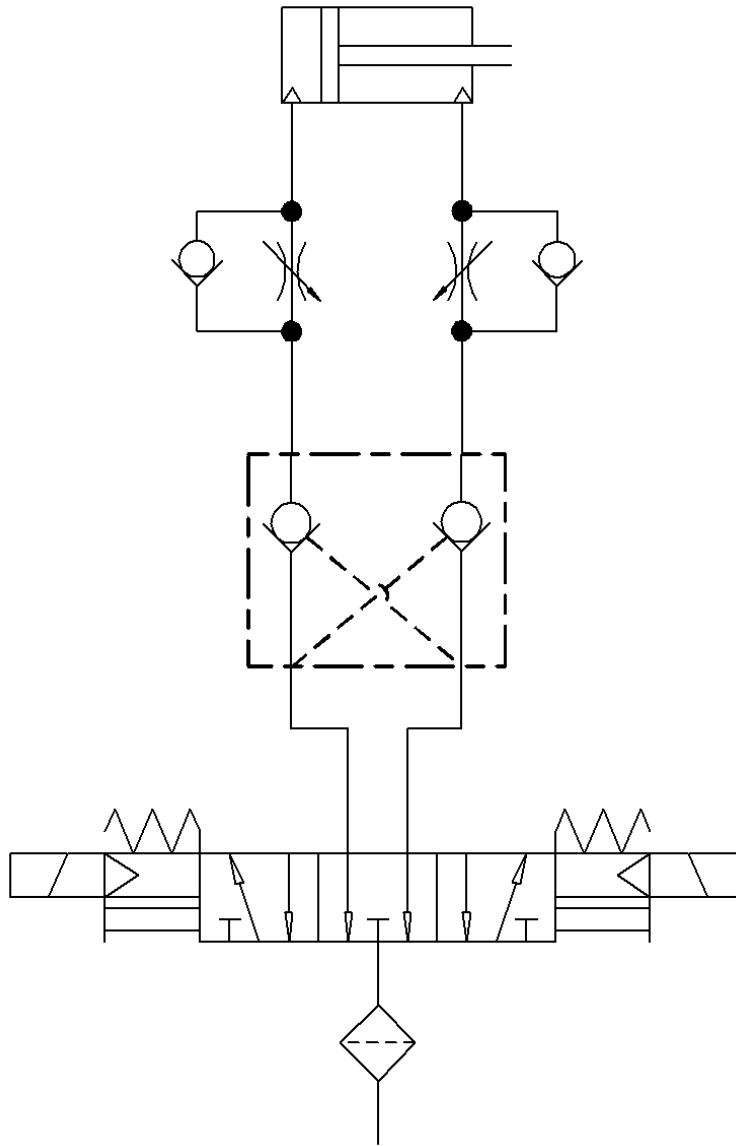

AUXILLARY SUPPLY LINE
DRY AIR
85 PSIG

CAP SCREW GRADE IDENTIFICATION - MARKINGS ON HEAD

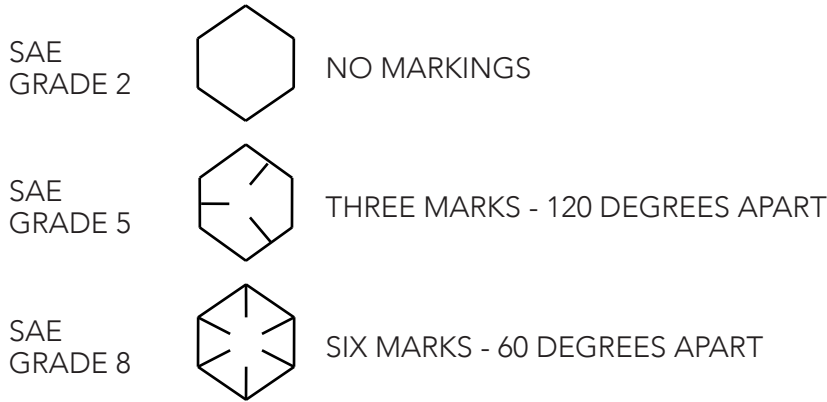

USE GRADE 2 TORQUES FOR STAINLESS STEEL FASTENERS AND CARRIAGE BOLTS.

CAP SCREW SIZE	TORQUE - FOOT-POUNDS					
	GRADE 2		GRADE 5		GRADE 8	
	DRY	LUBE	DRY	LUBE	DRY	LUBE
1/4"	5	4	8	6	12	9
5/16"	11	8	17	13	25	18
3/8"	20	15	30	23	45	35
7/16"	30	24	50	35	70	55
1/2"	50	35	75	55	110	80
9/16"	65	50	110	80	150	110
5/8"	90	70	150	110	220	170
3/4"	100	120	260	200	380	280
7/8"	140	110	400	300	600	460
1"	220	160	580	440	900	650

IMPORTANT! Do not operate or work on machine without reading and understanding the operator's manual.

Before starting engine/before starting machine operation

- | | |
|--|---|
| <input type="checkbox"/> Program rate controller and document settings | <input type="checkbox"/> Hydraulic hoses are secured properly |
| <input type="checkbox"/> All stop, tail, and turn lights function properly | <input type="checkbox"/> Gearcase oil level is correct |
| <input type="checkbox"/> Tire pressures are equal on each side of chassis | <input type="checkbox"/> Safety shields in place |
| <input type="checkbox"/> Battery condition and connection | <input type="checkbox"/> Spinner Assy moves through full range of operation |
| <input type="checkbox"/> Electrical connections are tight and secure | <input type="checkbox"/> Spinner discs and fins installed properly |
| <input type="checkbox"/> All fasteners are secure | <input type="checkbox"/> Spinner discs and fins are in acceptable condition |
| <input type="checkbox"/> Inverted "V" is secure and installed properly | <input type="checkbox"/> Material Divider assembly is square and secure |
| <input type="checkbox"/> Sensor(s) are functioning properly | <input type="checkbox"/> Material Divider is clean of build-up |
| <input type="checkbox"/> Lubricate all grease fittings | <input type="checkbox"/> Feedgate assembly is level |
| <input type="checkbox"/> Hydraulic oil level and line connections are tight | <input type="checkbox"/> Encoder installed and secured |
| <input type="checkbox"/> Hydraulic filters are current and gauge is functional | <input type="checkbox"/> Spinner sensor adjusted to proper gap |
| <input type="checkbox"/> Chain oiler tank is full and operates correctly | |

Start engine/Start and run to operational temperatures

- | | |
|--|--|
| <input type="checkbox"/> Hydraulic fittings are tight, no leaks * | <input type="checkbox"/> Conveyor control valve is operating correctly |
| <input type="checkbox"/> Check operation of all alarms | <input type="checkbox"/> Calibrate radar/ground speed input |
| <input type="checkbox"/> Hydraulic flow test: ____GPM @ operating engine RPM | <input type="checkbox"/> Test maximum conveyor(s) RPM |
| <input type="checkbox"/> Check main relief valve setting : ____ PSI | <input type="checkbox"/> Test right and left hand spinner speed; ensure difference is less than 30 RPM (when at operating RPM) |

Stop operation/Turn off engine and engage parking brake

- | | |
|---|--|
| <input type="checkbox"/> Visually check for leaks | <input type="checkbox"/> All oil levels full |
| <input type="checkbox"/> Check belt/chain tension and alignment | |

Perform Calibrations

- Product density testing, crush strength, and SGN scale (See Spread Pattern Calibration section for instructions).
- Catch tests of all products and at least 1 blend for conveyor calibration and document settings and product characteristics
- Spread pattern tests of all products and at least 1 blend and document settings and product characteristics

End of Season

- | | |
|---|---|
| <input type="checkbox"/> Empty unit of all material | <input type="checkbox"/> Clean unit inside and out |
| <input type="checkbox"/> Sand and touch-up paint as necessary | <input type="checkbox"/> Check for leaks |
| <input type="checkbox"/> Wash chain conveyor, lubricate thoroughly when dry | <input type="checkbox"/> Lubricate all grease fittings |
| <input type="checkbox"/> Check spinner discs and fins for wear | <input type="checkbox"/> Ensure all fasteners are secure and properly torqued |

HYDRAULIC SCHEMATICS

The following pages contain representative hydraulic schematics for all configurations of the L4000G4 model spreader.

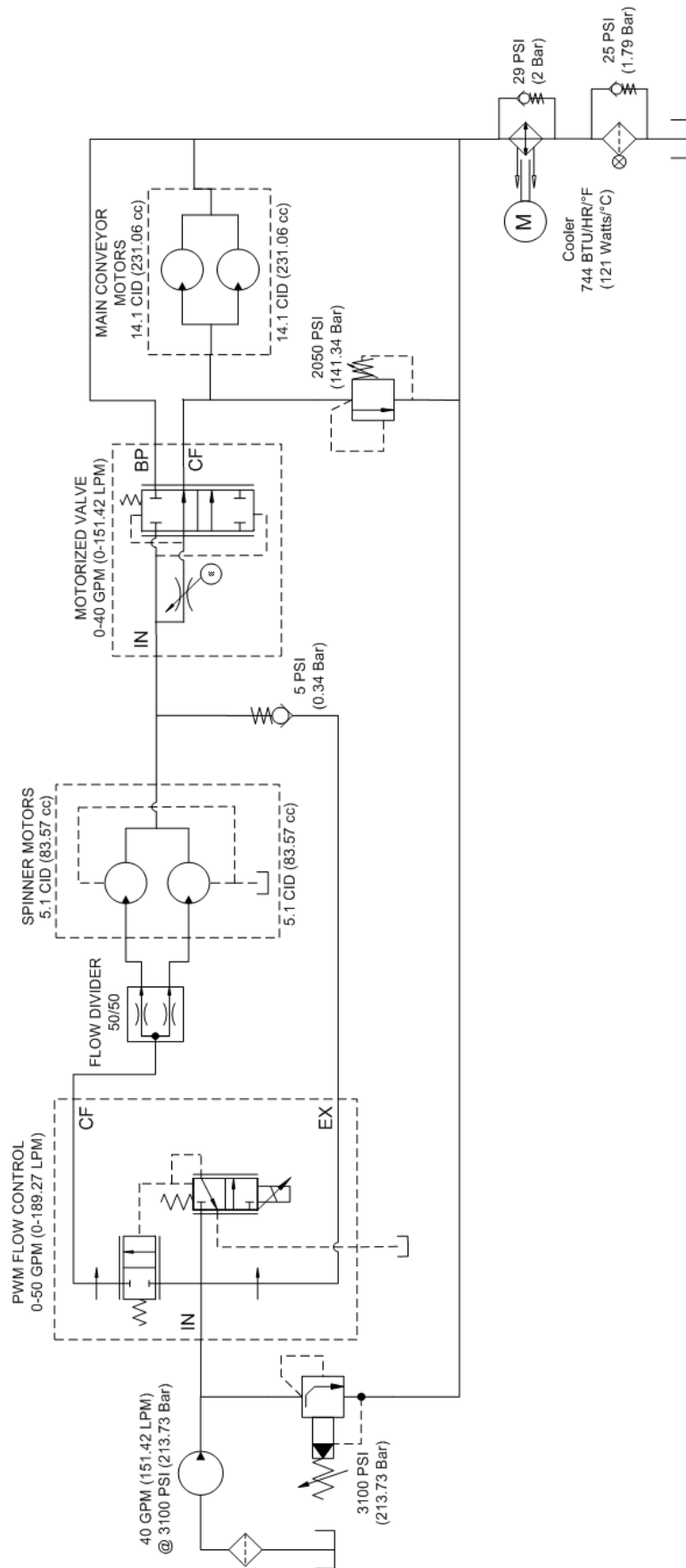

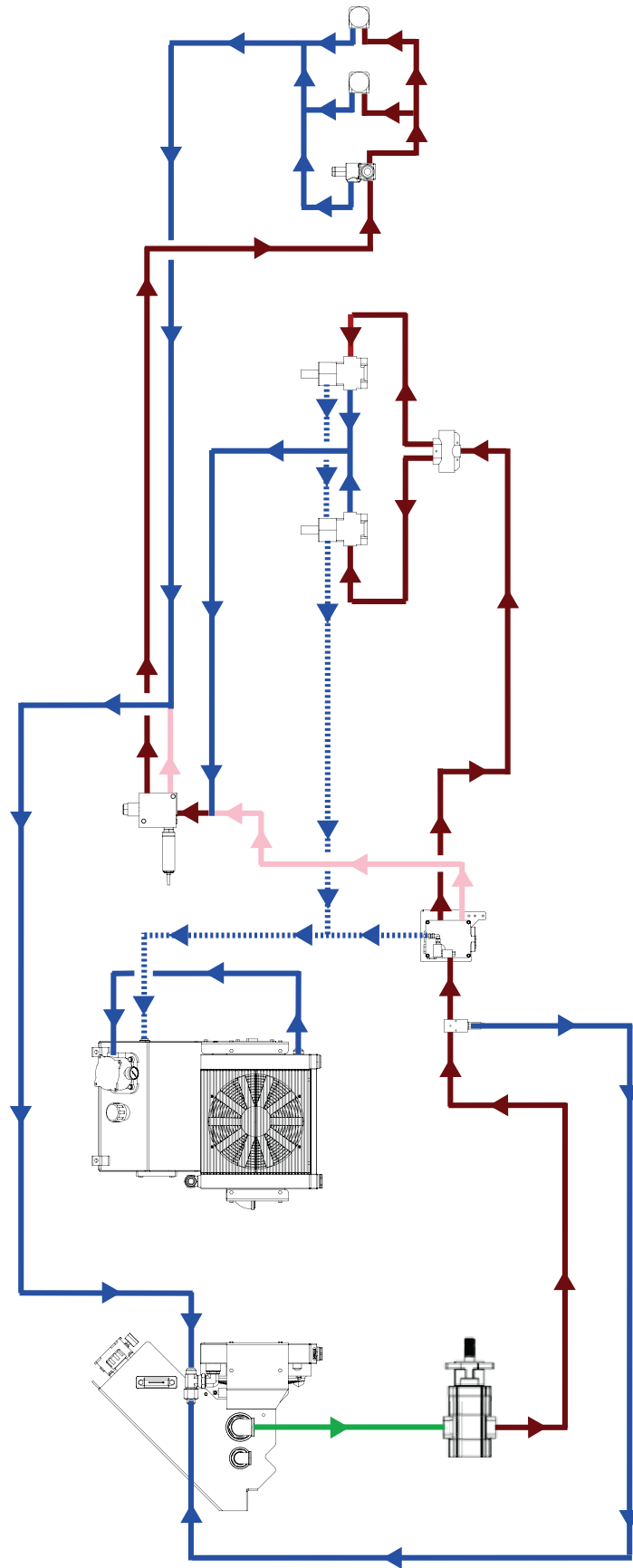

LEGEND	
	CONTROL FLOW (HIGH PRESSURE)
	EXCESS FLOW (HIGH PRESSURE)
	RETURN FLOW (LOW PRESSURE)
	CASE DRAIN (LOW PRESSURE)
	SUCTION FLOW (LOW PRESSURE)
	PRESSURE ONLY (HIGH PRESSURE)
	BI-DIRECTIONAL FLOW (HIGH PRESSURE)
	LOAD SENSE (HIGH PRESSURE)



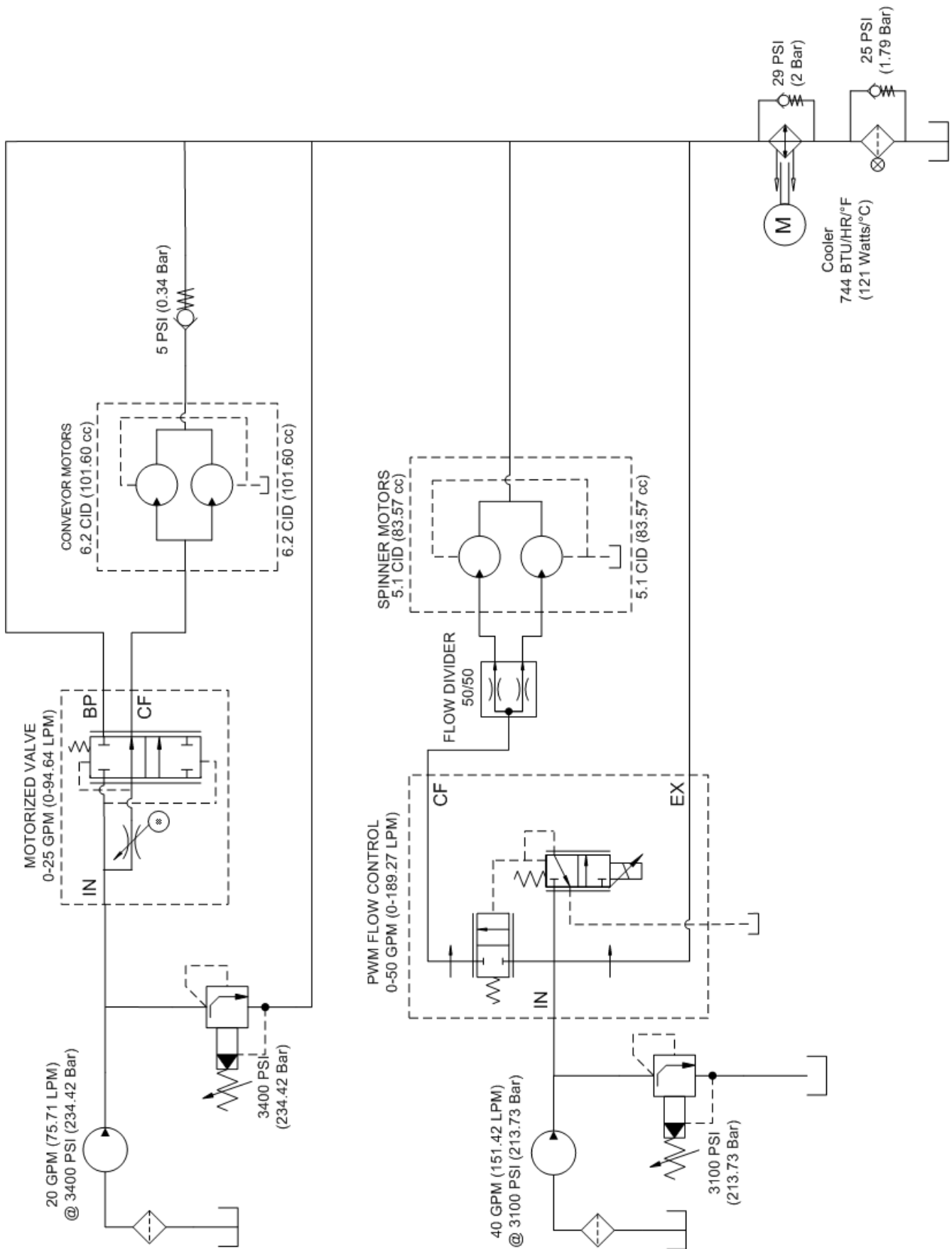

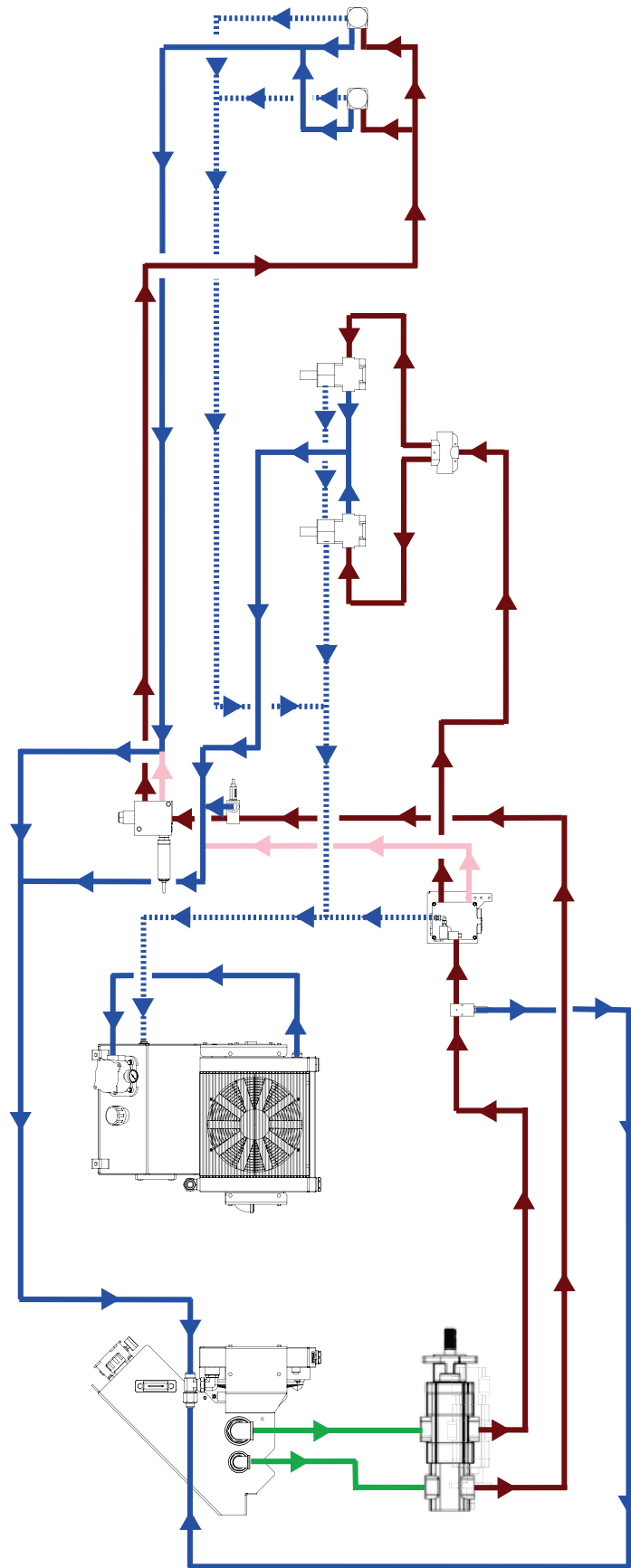

LEGEND	
	(HIGH PRESSURE)
	(HIGH PRESSURE)
	(LOW PRESSURE)
	(LOW PRESSURE)
	(LOW PRESSURE)
	(LOW PRESSURE)
	(HIGH PRESSURE)
	(HIGH PRESSURE)
	(HIGH PRESSURE)
	CONTROL FLOW
	EXCESS FLOW
	RETURN FLOW
	CASE DRAIN
	SUCTION FLOW
	PRESSURE ONLY
	BI-DIRECTIONAL FLOW
	LOAD SENSE



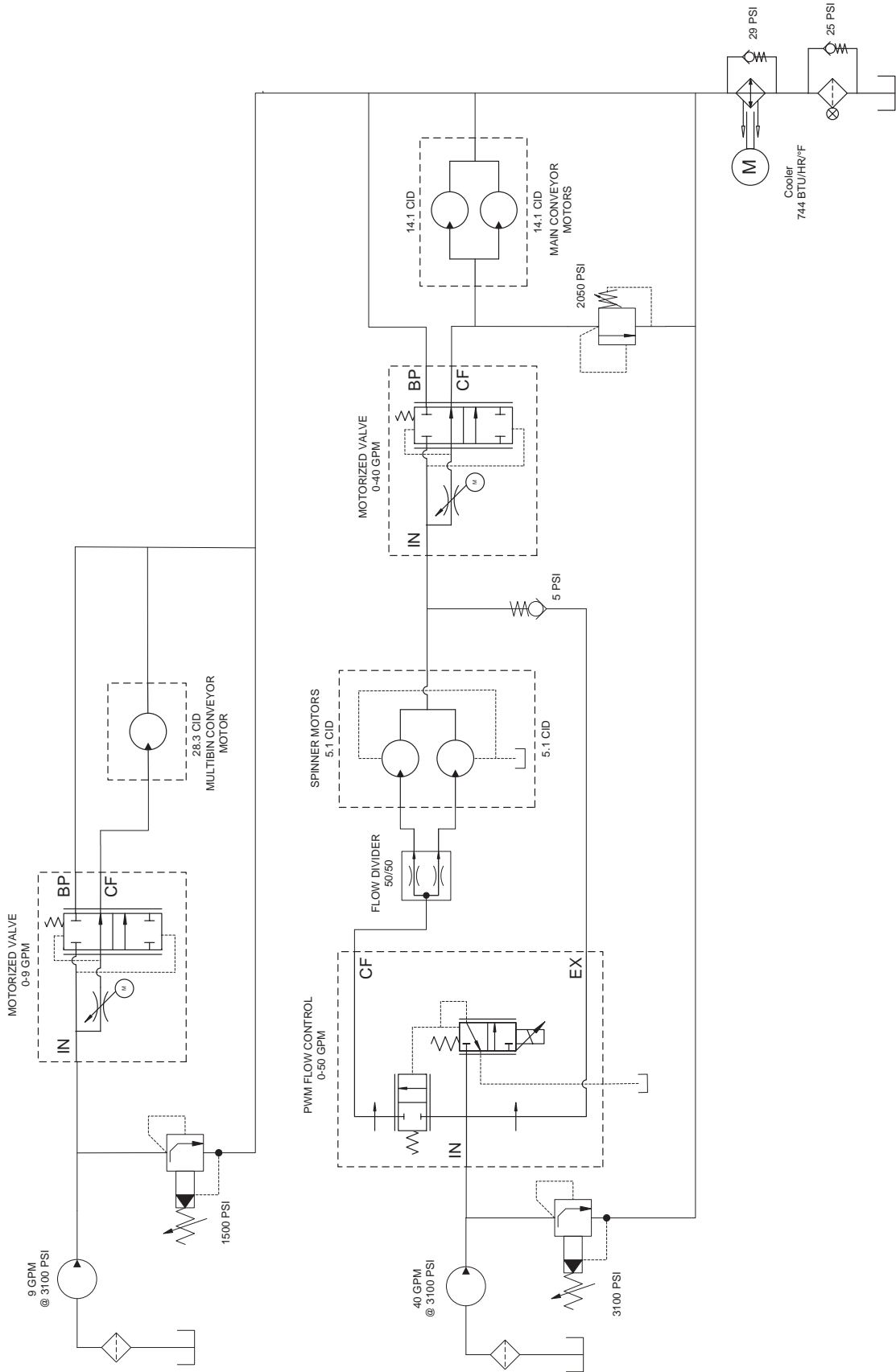

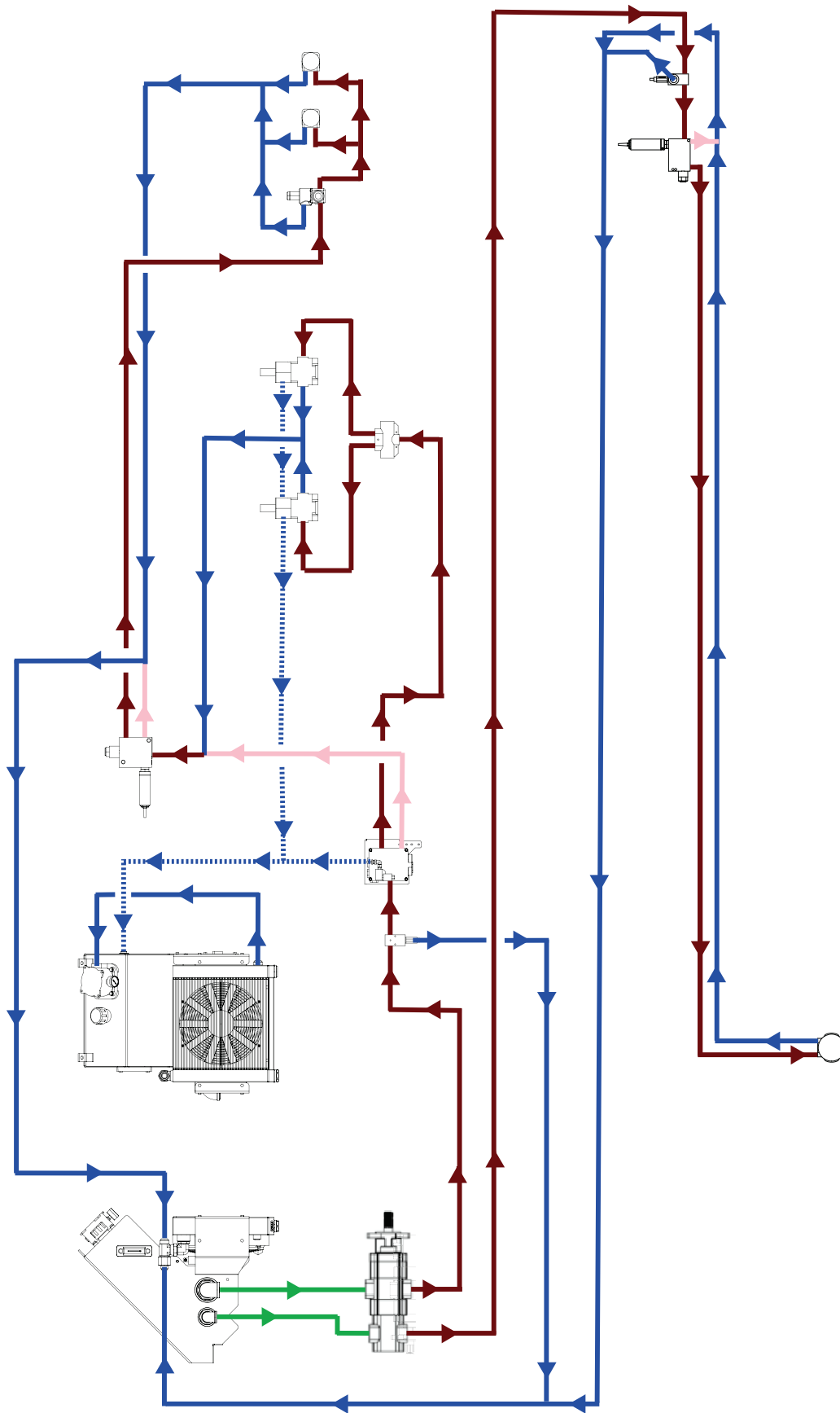

LEGEND	
	CONTROL FLOW
	EXCESS FLOW
	RETURN FLOW
	CASE DRAIN
	SUCTION FLOW
	PRESSURE ONLY
	BI-DIRECTIONAL FLOW
	LOAD SENSE

(HIGH PRESSURE)
 (HIGH PRESSURE)
 (LOW PRESSURE)
 (LOW PRESSURE)
 (LOW PRESSURE)
 (HIGH PRESSURE)
 (HIGH PRESSURE)
 (HIGH PRESSURE)

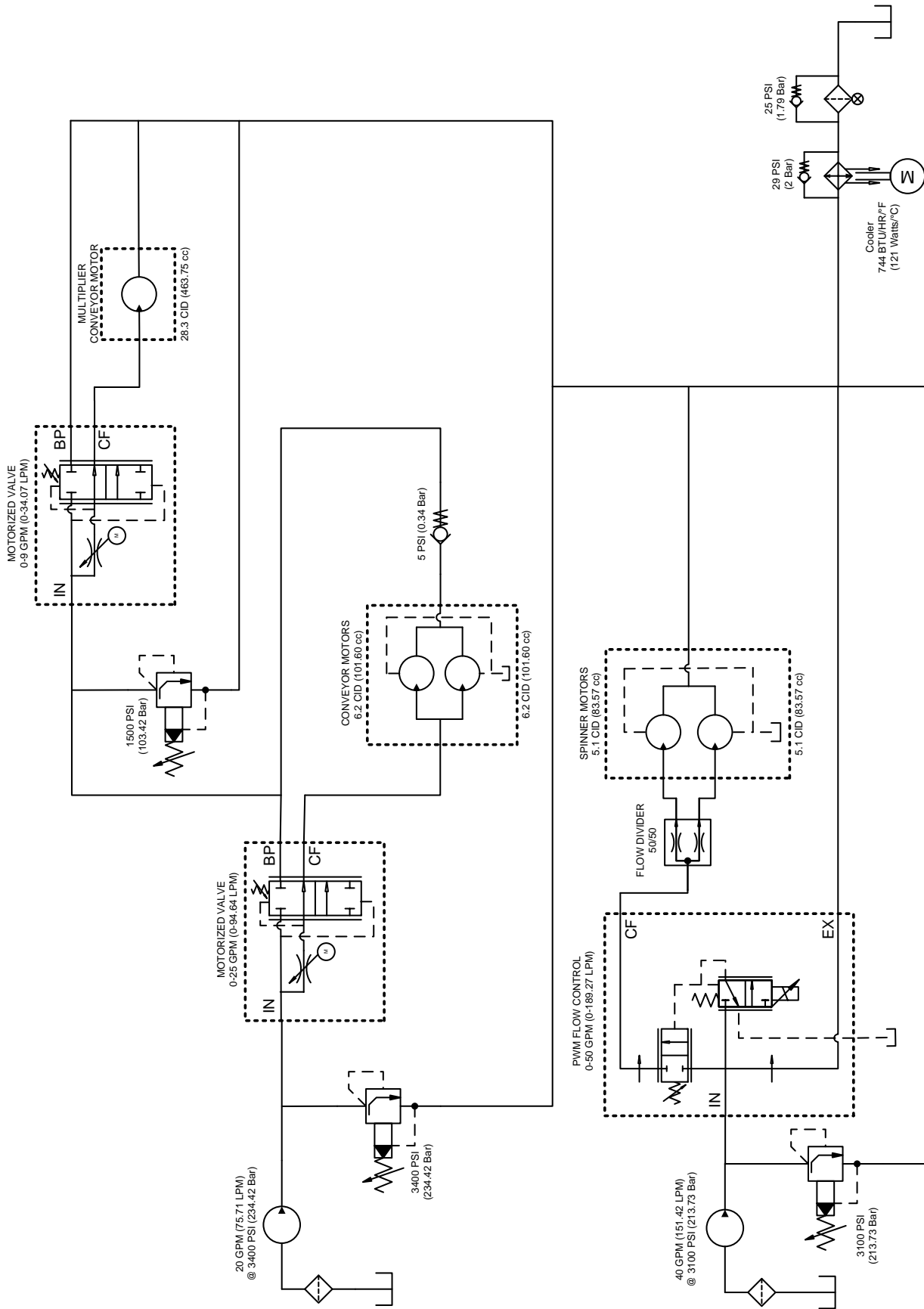

Hi Performance MultiApplier Complete Hydraulic Flow Diagram

L4000G4

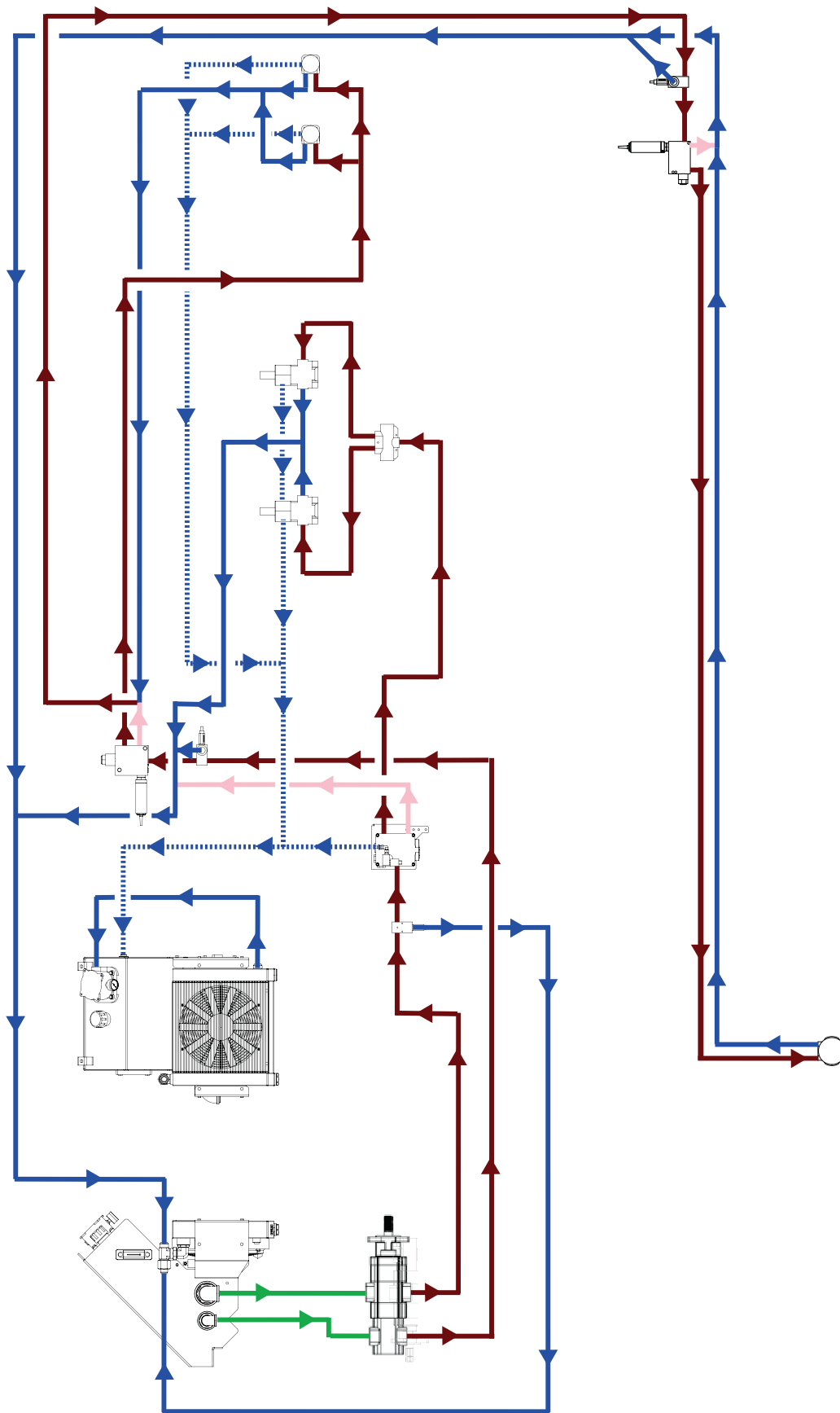

LEGEND	
(Solid Red Line)	(HIGH PRESSURE)
(Solid Blue Line)	(HIGH PRESSURE)
(Solid Pink Line)	(LOW PRESSURE)
(Dotted Blue Line)	(LOW PRESSURE)
(Dotted Red Line)	(LOW PRESSURE)
(Dotted Green Line)	(LOW PRESSURE)
(Dotted Yellow Line)	(HIGH PRESSURE)
(Dotted Purple Line)	(HIGH PRESSURE)
(Dotted Orange Line)	(HIGH PRESSURE)
(Dotted Brown Line)	(HIGH PRESSURE)
(Solid Green Line)	CONTROL FLOW
(Solid Blue Line)	EXCESS FLOW
(Solid Pink Line)	RETURN FLOW
(Dotted Blue Line)	CASE DRAIN
(Dotted Green Line)	SUCTION FLOW
(Dotted Yellow Line)	PRESSURE ONLY
(Dotted Purple Line)	BI-DIRECTIONAL FLOW
(Dotted Orange Line)	LOAD SENSE

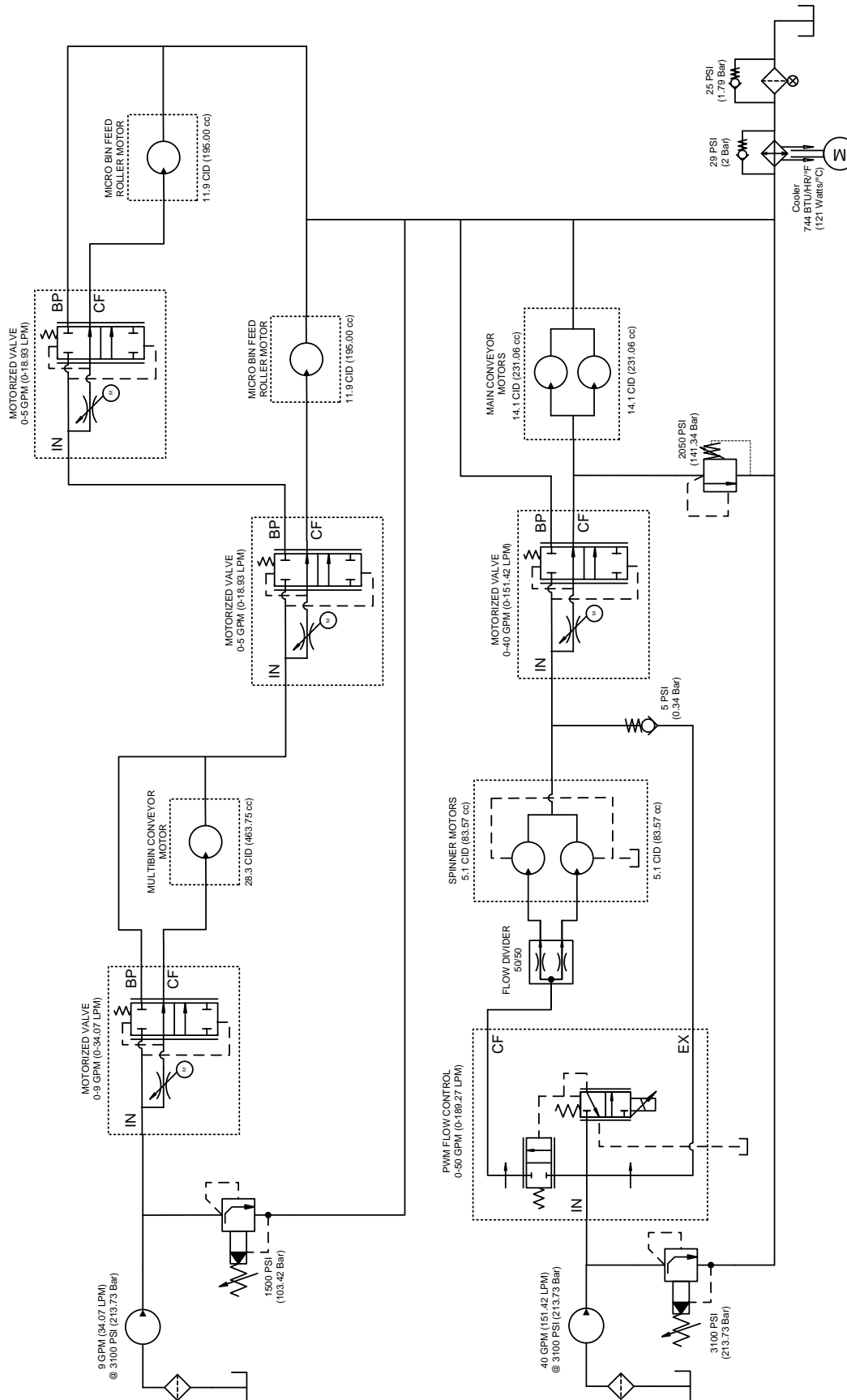

This page is intentionally left blank.

**WARNING**

Use great caution while working around the spreader. Contact with spinners and other moving parts is very dangerous. Do not adjust while machinery is moving, wear eye protection and avoid discharge from spinners. Do not ride on moving spreader.

A Catch Test is required prior to each season, before using a new product, or if a significant visible change has occurred with a product.

Catch Test

The CFR number, or cubic feet per revolution number, is a calibration number entered into the controller to determine rate output from the spreader's conveyor. A catch test is performed to verify accurate rate output per the controller.

NOTE: An optional calibration chute (P/N 312688) is available to simplify the catch test process. The calibration chute fits all New Leader spreader models with 30" wide conveyor bottoms. Contact your local New Leader dealer for details.

**WARNING**

To prevent injury, disable the spinners by unplugging the PWM valve before beginning the catch test procedure.

1. Disable the spinners by unplugging the PWM valve(s).
2. Move the spinner assembly to the 4" (102mm) position.
3. Remove the Material Divider back plate, and Vane Assembly (if applicable). Install calibration chute if available.
4. Position an end loader or other suitable device beneath the spinners to catch material.
5. Load material into all applicable bins.
6. Prime the conveyor as specified per the controller.
 - If using a calibration chute, run the conveyor just until material reaches the end. Remove any excess material that falls into the catching device.
 - If not using a calibration chute, run the conveyor until the spinner discs are full of material. Remove any excess product from the catching device. Do not remove material from spinner discs.
7. Measure the depth of material on the end of the conveyor to verify the constant number feedgate height information entered into the controller. Adjust feedgate height or recalibrate feedgate as necessary.
8. Verify that all other product settings entered into the controller are correct.
9. Select the correct bin in the controller for the first bin to be tested. Enter the anticipated weight of product to be dispensed from the conveyor.
10. Start the engine and engage hydraulics. Allow to run for several minutes to bring hydraulic oil up to operating temperature. Bring engine up to operating RPM.
11. Following the setup wizard on the controller, run the catch test. The conveyor will start dispensing material, and automatically shut off when the estimated amount of product is dispensed.
12. If not using a calibration chute, leave the material on the spinner discs. Weigh the amount of product that the conveyor actually dispensed into the catching device, and note the result.
13. Enter the actual weight of material dispensed into the controller. The controller will then automatically perform the calibration.
14. Repeat Steps 5 - 12 for all other applicable bins, if an insert bin is installed.
15. Once satisfactory results have been achieved for all applicable bins, turn the engine off, replace the back plate on the Material Divider, return the spinner assembly to its original position setting, and plug the PWM valve(s) back in.

NOTE: For more information on controller operations and setup, contact your local dealer.



WARNING

Use great caution while working around the spreader. Contact with spinners and other moving parts is very dangerous. Do not adjust while machinery is moving, wear eye protection and avoid discharge from spinners. Do not ride on moving spreader.

NOTICE!

Spinner assembly and material divider have NOT been adjusted at the factory. Before spreading material, spread pattern tests must be conducted to properly adjust the spread pattern. A spread pattern test kit is available for this purpose.
 THE MANUFACTURER OF THIS SPREADER WILL NOT BE HELD LIABLE FOR MISAPPLIED MATERIAL DUE TO AN IMPROPERLY ADJUSTED SPREADER.

Spread Pattern

Product quality will affect spread pattern and product performance. Spread pattern testing is required to ensure proper application of material. Larger products will produce wider swath widths.

Spread pattern is adjusted using one or more of the following:

- Point of material delivery on spinner discs
- Spinner speed
- Angle of the distributor fins on the spinner discs

Since adjustments will vary for each job, trial and experience must be used to determine the adjustments required to obtain the swath width and spread pattern desired.

Spread Pattern Test Kit

Spread Pattern Test Kit, part no. 313960, includes the following:

DESCRIPTION	QTY	DESCRIPTION	QTY
Box - Plastic Storage	1	Scale – Density	1
Center Collection Tray - Blue	1	Data Sheet – 100 Ct. Booklet	1
Collection Tray - Brown	22	Funnel	1
Divider Screen	23	Flag	5
Assy – Test Tube Rack	1	Rope – 120' marked	1
Test Tube	23	Stake	2

NOTE: If desired, a material calibration kit is available to aid in measuring product quality. Contact your local dealer for details.

Spinners

NOTICE! Spinner discs and fins must be kept clean and polished. Even a small build-up on a spinner fin can significantly affect the spread pattern. Rusty, rough, bent or worn fins will produce poor spread patterns.

In general, critical spinner speed will fall somewhere between 600 and 900 RPM. Spinner speed is adjusted by changing the settings in the controller. Proper spinner speed adjustment is critical in obtaining optimal spread patterns. The best spinner speed to use will depend entirely on the material being spread, and must be determined by testing.

Spreader Preparation

The spreader to be tested must be in good mechanical condition and properly adjusted. Refer to operator's manual for details.

All damaged and worn parts must be replaced. Spinner discs and fins must be free of any material build-up, rust or paint.

Fill the hopper with the material to be spread. Run the material out to the end of the conveyor.

Set the feedgate and the in-cab controller to deliver the required rate per acre. Make sure the feedgate is level and the indicator reflects the actual gate opening measured by standing a tape measure vertically in the material.

NOTE: Do not match slope of endgate when making this measurement. Measurement must be perpendicular to conveyor.

Adjust the spinner assembly by turning the crank or, if an actuator is installed, change the setting in the controller. To begin testing, position the spinner according to following chart.

NOTE: This chart is to be used as a reference only to begin testing.

			SIMPLE START SETTINGS			
Material	Density	Ground Speed (mph)	Rate (lbs)	Feedgate (in)	Spinner Frame Setting	Spinner RPM
Lime	90	11*	1000-5000	6	.5"	600
			2000-8000	12	.5"	600
Urea	46	18	110	2.5	4	800
			225	2.5	3.5	800
			450	2.5	2.5	800
Corn Blend	53	18	125	2.5	3.5"	800
			250	2.5	2.5"	800
			500	2.5	0.7	800
All other fertilizer types and blends	64	18	150	2.5	3.5"	800
			300	2.5	2.5"	800
			600	2.5	1.2	800
* 15 mph when using high performance (HP) hydraulics.						

Test Procedure

Using the data sheets supplied with the kit, document all spreader information and adjustments as necessary. See Figure 1.

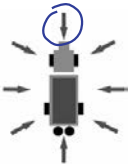
		SPREAD PATTERN DATA SHEET New Leader Manufacturing		1330 76th Ave SW Cedar Rapids, IA 52404-7052 (319) 363-8281		
Pattern Test No. <i>1</i>	Rev.	Spreader Model: <i>L4000G4</i>	 (Circle Direction of Wind Relative to Spreader)			
Site: <i>NLM</i>		Serial No. <i>432165</i>				
Date: <i>10/07/2016</i>	Time: <i>10am</i>	Conveyor Type: <i>#4 BOC</i>				
Material Name: <i>MAP</i>		Fan Frame Setting: <i>3.25</i> in.				
Density: <i>65</i> lb/ft ³		Feedgate Height: <i>3"</i> in.				
Crush Strength: <i>6</i>		Fin Position: <i>1-2-1-2</i>				
SGN: <i>324</i>						
Application Rate: <i>320</i> lbs/acre		CFR/Constant: <i>.232</i>				Wind: From <i>Straight</i> at <i>5</i> MPH
						Relative Humidity: <i>41%</i> %
						Temperature: <i>67</i> °F
Spinner Speed: <i>780</i> RPM		Controller Vehicle Speed: <i>12</i> MPH	Controller Swath Width: <i>90</i> ft.			

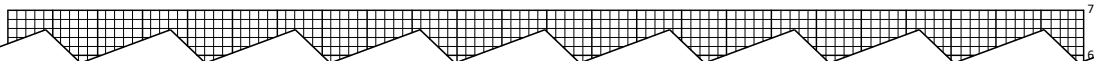

Figure 1

Select an area for testing measuring at least 120 feet x 200 feet (37 m x 61 m), and with a slope of less than two degrees.

All testing should be done when the wind velocity is less than 5 MPH (8.05 km). If wind is present, testing must be done with spreader traveling parallel (within ± 15 degrees) to the wind direction.

Do not allow loaded spreader to sit for more than one hour prior to testing.

At this stage of testing, drive the spreader over the collection trays in ONLY ONE DIRECTION.

Insert a plastic grid into each of the 23 collection trays. Position the blue collection tray in the center of the spreader's path with the longest dimension of the tray parallel to the direction of travel. Position the first left-hand and right-hand trays 10' (3m) from center, and all subsequent trays on 5' (1.5m) centers.

Four-Wheeled Vehicles

For four-wheeled application vehicles, position the spreader at the beginning of the course so that the vehicle will straddle the center collection tray. See Figure 2.

Engage spinners before navigating the course. As the vehicle approaches the flag positioned 75' before the row of collection trays, engage the conveyor(s). Do not shut the conveyor(s) off until the vehicle approaches the second flag.

Drive spreader completely through course at normal operating speeds.

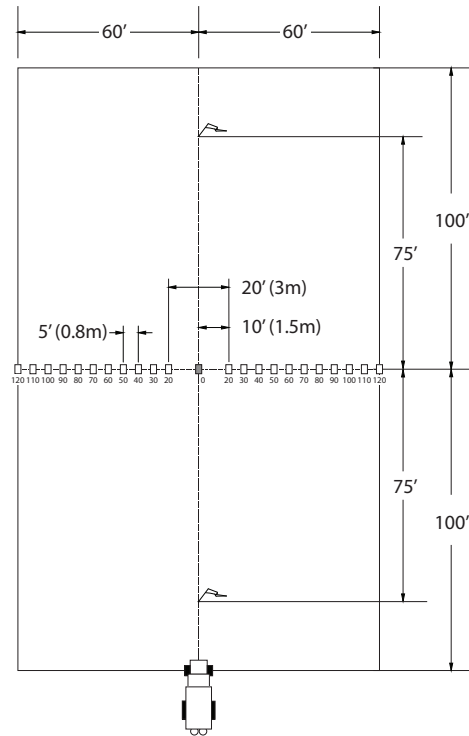

Figure 2 – Four-Wheeled Vehicles

Three-Wheeled Vehicles

For three-wheeled application vehicles, straddling the center tray is not possible. Place the center collection tray beneath the vehicle just behind the front tire when the spreader is in position at the beginning of the course. See Figure 3.

Engage both the spinners and conveyor(s) before navigating the course. Do not shut the conveyor(s) off until the vehicle approaches the second flag.

Drive spreader completely through course at normal operating speeds.

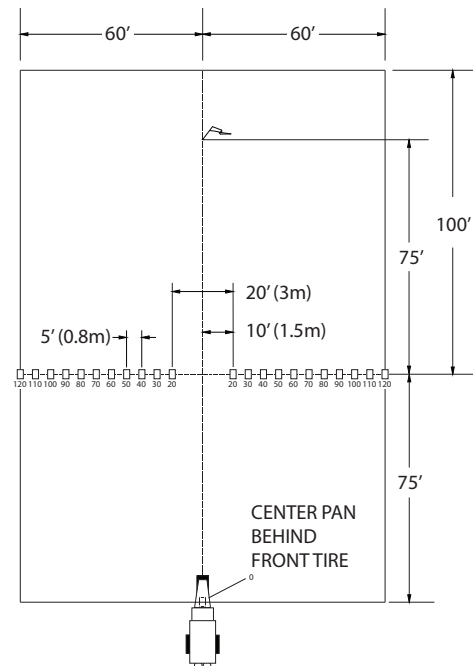

Figure 3 – Three-Wheeled Vehicles

Test Results

After navigating the course, shut the spreader down and park in a secure location.

Using the funnel, transfer the contents of each collection tray into its corresponding test tube beginning at one end of the trays and working towards the opposite end.

If spreading a blend of materials, inspect all tubes to determine if the blend is consistent across the entire swath width. If the blend is not consistent, use a narrower swath width. The swath width should be based on the material thrown the shortest distance.

Record each test tube's volume in the box on the data sheet under the corresponding tray position and graph the spread pattern profile. See Figure 4.

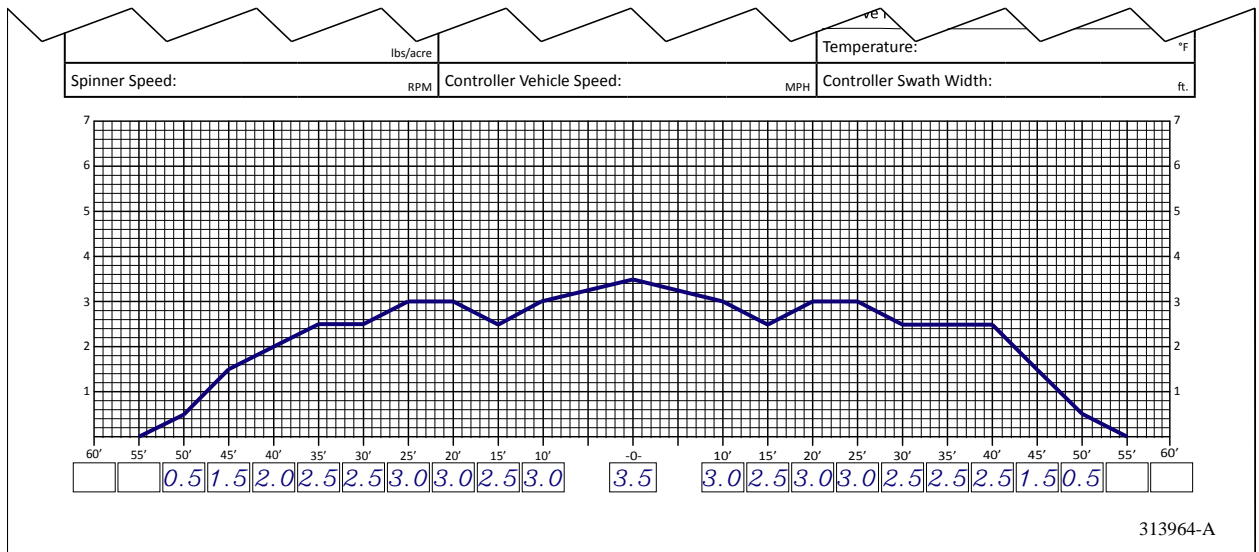

Figure 4

Looking at the material in the test tubes and the graphed profile on the data sheet, compare the overall shape of the spread pattern to the three acceptable patterns, shown in Figure 5. If an acceptable pattern has not been achieved, proceed to "Troubleshooting". Once an acceptable pattern has been achieved, proceed to "Determining Driving Centers".

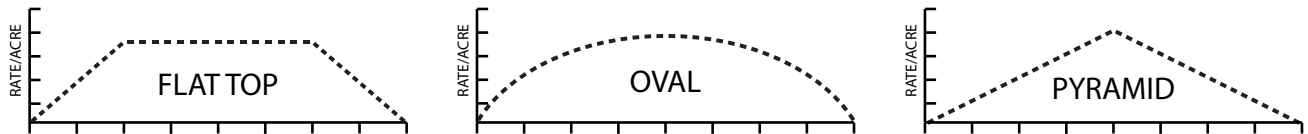

Figure 5 – Acceptable Patterns

Troubleshooting

NOTE: It is highly recommended that **ONLY ONE ADJUSTMENT** be made between test samples taken. If more than one adjustment is made, it will be difficult to determine which adjustment was responsible for the change in pattern shape.

Problem	Pattern	Recommended Adjustments
Heavy Directly Behind the Vehicle		<ol style="list-style-type: none"> 1. Move the spinner forward (toward the conveyor).
Light Directly Behind the Vehicle		<ol style="list-style-type: none"> 1. Move the spinner rearward (away from conveyor).
Light Outside Vehicle's Tire Tracks		<ol style="list-style-type: none"> 1. Check spinner fins for material buildup, rust or paint. 2. Increase spinner RPM. 3. Move spinner fins to 2 - 3 - 2 - 3 positions. See Figure below.
Pattern Off Center		<ol style="list-style-type: none"> 1. Check to see feedgate is level and free of caked material. 2. Make sure hillside divider spinner assembly and material divider are mounted squarely and centered. 3. Testing should be done parallel to wind.

Figure 6

Spinner fins are adjustable to radial angle as shown in Figure 7. Refer to Figure 6 for fin adjustment recommendations.

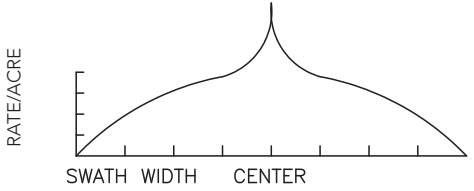
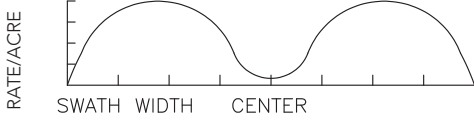
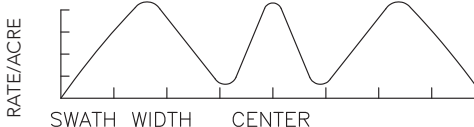
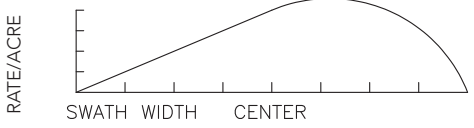
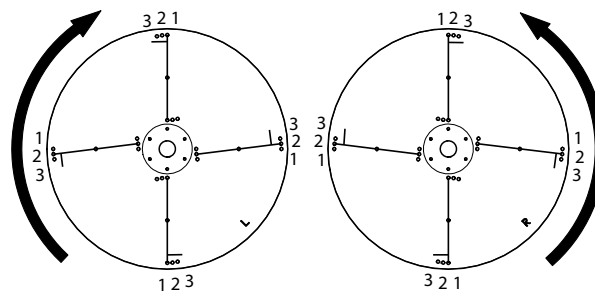

Figure 7 - Spinner Fin Adjustment

Determining Driving Centers

Once an acceptable pattern is obtained, as shown in Figure 5, driving centers can be determined. To determine optimum driving centers (effective swath width), determine the average amount of material in the center of the pattern. Figure 8 shows an example data sheet recorded from the profile shown in Figure 9. Based on the example, the average amount of material in the center of the pattern is 3.0, as indicated with the red dotted line.

Next, locate the points on both the left and right side of the pattern where the amount of material is half the average amount at the center of the pattern. In the example shown in Figure 8, these points are located 45' to the left of center, and 45' to the right of center. The distance between these two points (90') represents the driving centers to use.

NOTE: Once the effective swath width has been established, a change in the controller may be required.

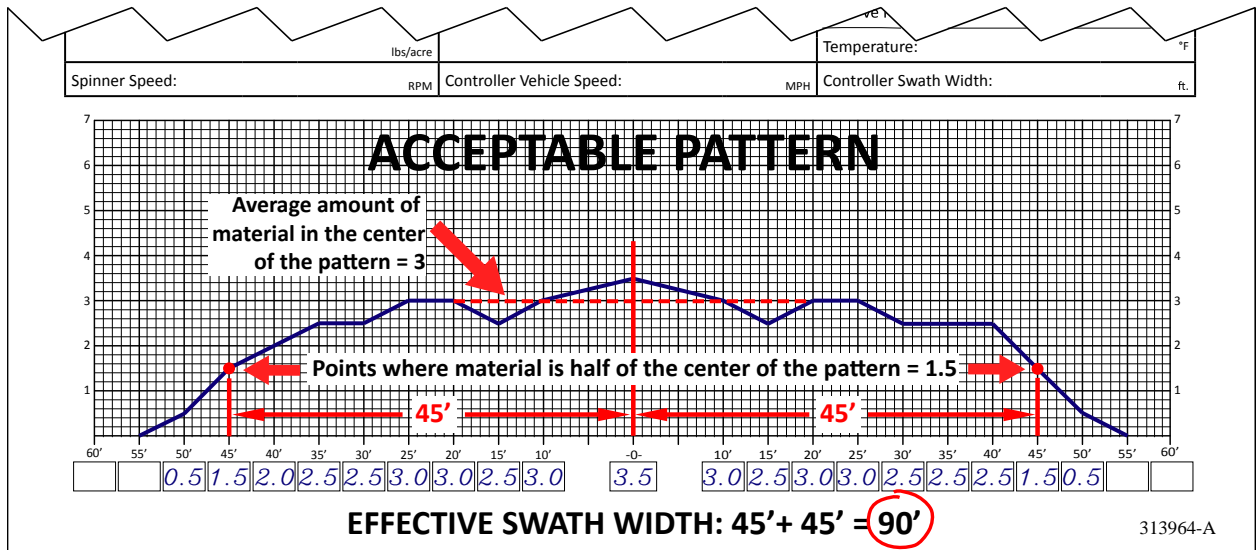

Figure 8 - Effective Swath Width

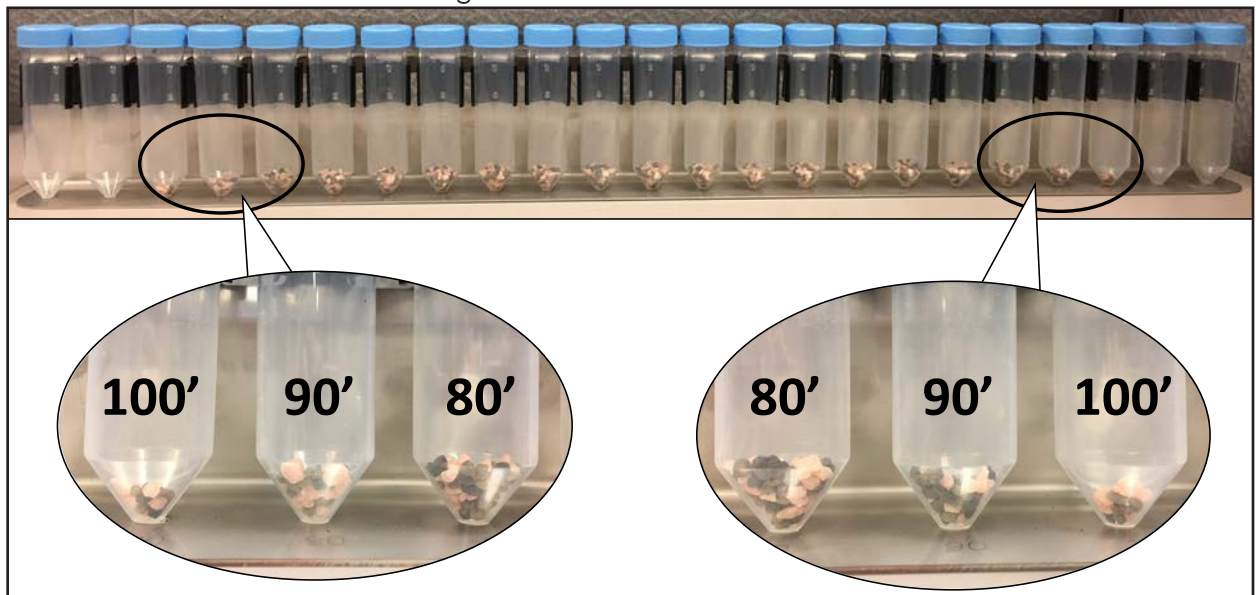

Figure 9

Verifying Driving Centers

Once optimum driving centers (effective swath width) have been established, conduct a final "S" pass over the trays to verify. Refer to Figure 10.

1. With both the spinners and conveyor turned off, drive the spreader through the center of the course, establishing an "AB" line. If the spreader vehicle is a three-wheel type, remove the center pan.
2. Line the vehicle up with either end of the row of collection trays, at a distance from the "AB" line equal to the effective swath width.
3. With both the spinner and conveyor engaged, drive past the trays.
4. Switch back and drive over the center of the trays, down the "AB" line.
5. Drive through the row of trays and switch back once again, driving past the trays on the opposite side, at an equal distance from the "AB" line as the first pass.

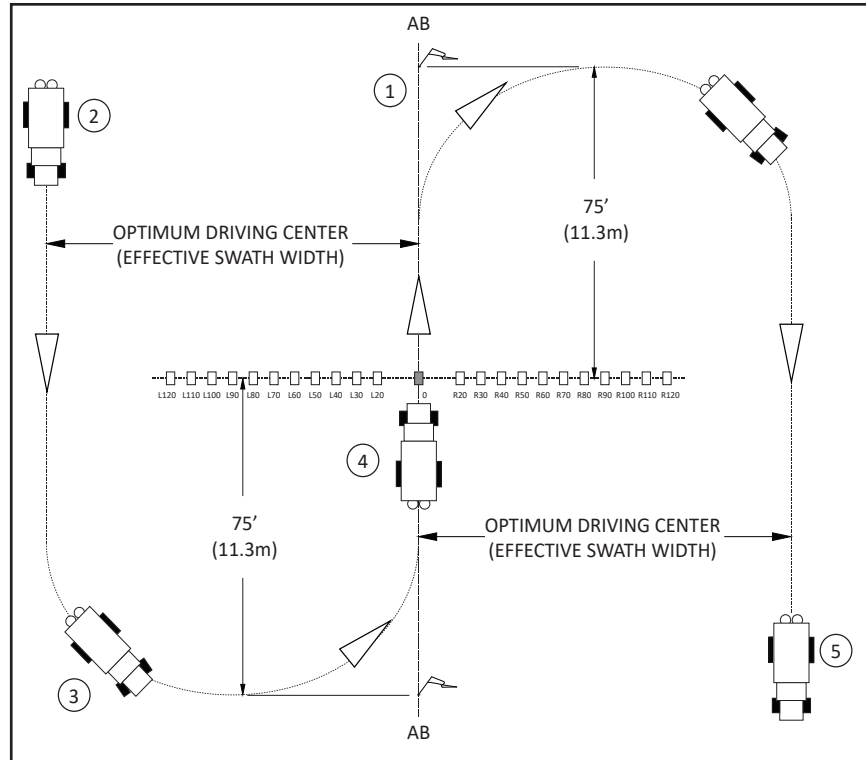

Figure 10

If the driving centers were determined correctly, all trays should have a similar amount of material, showing a near flat profile in the test tubes. If the trays near the center of the row contain more material than the others, increase driving centers. If the trays near the center of the row contain less material, decrease driving centers.

NOTE: If spreading a blend of materials, verify blend of all products is consistent across all tubes.