

NEW LEADER



AGCO L4000G4 / MULTAPPLIER / MULTIBIN

UNIT SERIAL NO. _____

MULTAPPLIER/MULTIBIN SERIAL NO. _____

MANUAL NUMBER: 306299-AA-H

EFFECTIVE 06/2016



1330 76TH AVE SW
CEDAR RAPIDS, IA 52404-7052
PHONE (319) 363-8281 | FAX (319) 286-3350
www.highwayequipment.com

Copyright 2003 Highway Equipment Company, Inc.

TABLE OF CONTENTS

Table of Contents.....	2
Interactive Features.....	4
Warranty.....	6
Preface.....	7
Safety.....	8
Safety Decals	9
Informational Decals	14
General Safety Rules-Operations.....	16
General Safety Rules-Maintenance	18
General Safety Rules-Installation.....	20
Installation Instructions.....	21
Lifting the Spreader	21
Side Board Installation	21
Hydraulic Hose Installation	22
Installation Guide	23
Filling Hydraulic System	24
Insert Installation Instructions.....	25
Spreader Preparation.....	25
Feedgate Adjustment.....	27
Lower Divider - Multibin	31
Hydraulics	32
Hydraulic Hose Installation	33
Hillside Divider & Conveyor Cover - MultApplier.....	33
Micro Cover Installation.....	35
Electrical Connections.....	37
Insert Removal/Endgate Installation.....	37
General Description.....	39
Introduction.....	40
Dimensions & Capacities	44
Initial Startup.....	50
G4 Spinner Squaring	53
General Operating Procedures	57
Field Testing	57
General Operating Procedures	57
Lubrication & Maintenance.....	59
Preventative Maintenance Pays!	59
Hydraulic System.....	59
Service Schedule.....	59
Conveyor Gearcase	60
Hydraulic Hose	60
Conveyor Chain.....	61
Lubrication.....	61
Tension	62
#4 BOC Conveyor Belt Maintenance.....	62
Bin Sensor	63
Lubrication of Bearings	63
Fasteners.....	63
Clean-Up	63
Lubricant & Hydraulic Oil Specifications.....	65
Hydraulic System.....	65
Gearcase Lubricant	65
Grease Gun Lubricant	65
Chain Conveyors	65



Lubrication & Maintenance Chart 66

Troubleshooting 68

 MultiBin Cover Air Schematic 70

Standard Torques 71

Pre- and Post-Season Check Lists 72

Hydraulics 73

 Hydraulic System Service Videos 73

 Hydraulic Schematics 73

Spread Pattern Testing..... 85

 Crushing Strength 85

 SGN 85

 Catch Test..... 85

 Product Setup Guidelines 86

 Crush Test 87

 SGN Scale Test 88

 Catch Test 90

 Spread Pattern Test Kit 91

 Spinners 92

 Spreader Preparation 92

 Test Procedure 93

 Data Recording 94

 Driving Methods 95

 Troubleshooting..... 96

INTERACTIVE FEATURES**NOTE:**

This manual incorporates several interactive features to provide supplemental information and ease of navigation. The information below is to aid in the identification and use of these features.

Hyperlinks

Hyperlinks provide direct access to a specific destination when clicked. The entire Table of Contents of this manual is hyperlinked to provide quick access to all sections of this manual when viewing the electronic version.

Hyperlinks within the content are denoted by **blue, bold underlined text**. Electronic format viewers can click these links for direct access to New Leader online features. Internet access is required.

Quick Reference (QR) Codes

Quick reference codes provide direct access to a specific destination when activated. An example is provided below. In the printed version of this manual, viewers may scan the codes with a supporting mobile device for direct access to New Leader online features. Mobile data is required.

The electronic version of this manual provides the option to scan codes on-screen, or to click the code like a button. Internet access/mobile data is required.



Click or Scan - Highwayequipment.com



NOTES

This page is intentionally left blank.

Insert Current New Leader
Warranty

PLEASE ! ALWAYS THINK SAFETY FIRST !!

The purpose of this manual is to familiarize the person (or persons) using this unit with the information necessary to properly install, operate, and maintain this system. The safety instructions indicated by the safety alert symbol in the following pages supersede the general safety rules. These instructions cannot replace the following: the fundamental knowledge that must be possessed by the installer or operator, the knowledge of a qualified person, or the clear thinking necessary to install and operate this equipment. Since the life of any machine depends largely upon the care it is given, we suggest that this manual be read thoroughly and referred to frequently. If for any reason you do not understand the instructions, please call your authorized dealer or our Product Sales and Support Department at 1-888-363-8006.

It has been our experience that by following these installation instructions, and by observing the operation of the spreader, you will have sufficient understanding of the machine enabling you to troubleshoot and correct all normal problems that you may encounter. Again, we urge you to call your authorized dealer or our Product Sales and Support Department if you find the unit is not operating properly, or if you are having trouble with repairs, installation, or removal of this unit.

We urge you to protect your investment by using genuine HECO parts and our authorized dealers for all work other than routine care and adjustments.

Highway Equipment Company reserves the right to make alterations or modifications to this equipment at any time. The manufacturer shall not be obligated to make such changes to machines already in the field.

This Safety Section should be read thoroughly and referred to frequently.

ACCIDENTS HURT !!!

ACCIDENTS COST !!!

ACCIDENTS CAN BE AVOIDED !!!





TAKE NOTE! THIS SAFETY ALERT SYMBOL FOUND THROUGHOUT THIS MANUAL IS USED TO CALL YOUR ATTENTION TO INSTRUCTIONS INVOLVING YOUR PERSONAL SAFETY AND THAT OF OTHERS. FAILURE TO FOLLOW THESE INSTRUCTIONS CAN RESULT IN INJURY OR DEATH.

In this manual and on the safety signs placed on the unit, the words "DANGER," "WARNING," "CAUTION," and "NOTICE" are used to indicate the following:



DANGER

Indicates an imminently hazardous situation that, if not avoided, WILL result in death or serious injury. This signal word is to be limited to the most extreme situations and typically for machine components that, for functional purposes, cannot be guarded.



WARNING

Indicates a potentially hazardous situation that, if not avoided, COULD result in death or serious injury, and includes hazards that are exposed when guards are removed. It may also be used to alert against unsafe practices.



CAUTION

Indicates a potentially hazardous situation that, if not avoided, MAY result in minor or moderate injury. It may also be used to alert against unsafe practices.

NOTICE!

Is used for informational purposes in areas which may involve damage or deterioration to equipment but generally would not involve the potential for personal injury.

NOTE:

Provides additional information to simplify a procedure or clarify a process.

The need for safety cannot be stressed strongly enough in this manual. At Highway Equipment Company, we urge you to make safety your top priority when operating any equipment. We firmly advise that anyone allowed to operate this machine be thoroughly trained and tested, to prove they understand the fundamentals of safe operation.

The following guidelines are intended to cover general usage and to assist you in avoiding accidents. There will be times when you will run into situations that are not covered in this section. At those times the best standard to use is common sense. If, at any time, you have a question concerning these guidelines, please call your authorized dealer or our Product Sales & Support Department at (888) 363-8006.



SAFETY DECAL MAINTENANCE INSTRUCTIONS

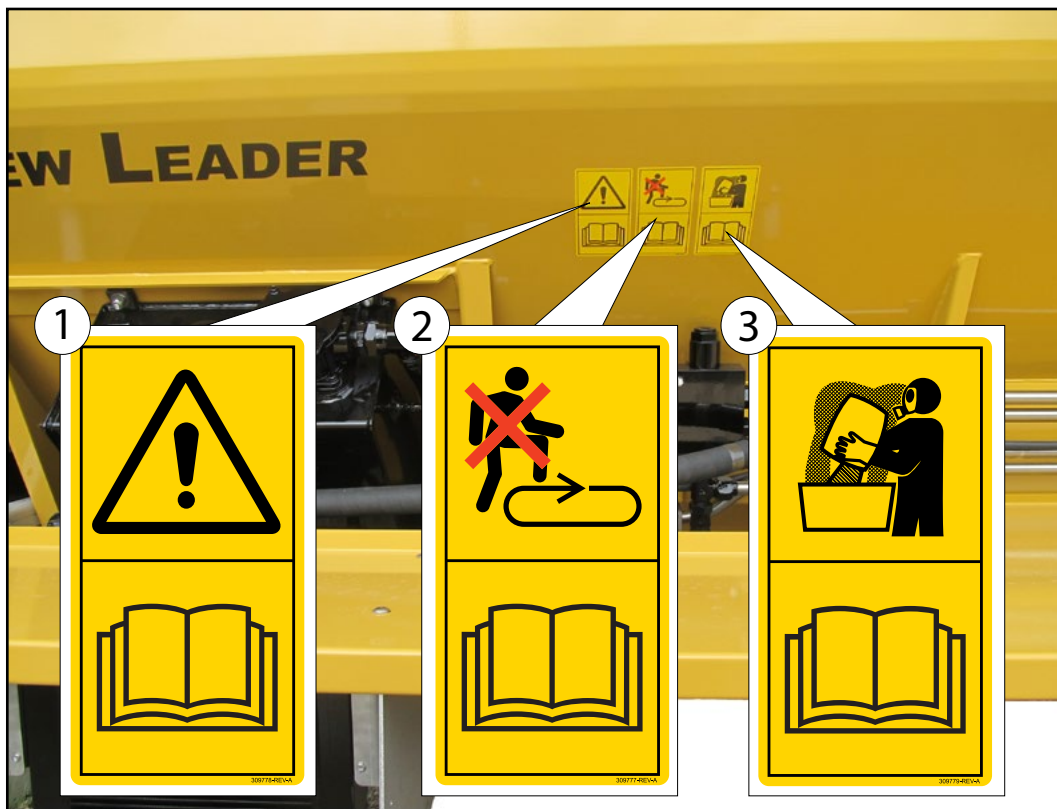
1. Keep safety decals and signs clean and legible at all times.
2. Replace safety decals and signs that are missing or have become illegible.
3. Replaced parts that displayed a safety sign should also display the current sign.
4. Safety decals or signs are available from your dealer's Parts Department or our Cedar Rapids factory.

SAFETY DECAL INSTALLATION INSTRUCTIONS

1. Clean Surface
Wash the installation surface with a synthetic, free-rinsing detergent. Avoid washing the surface with a soap containing creams or lotion. Allow to dry.
2. Position Safety Decal
Decide on the exact position before application. Application marks may be made on the top or side edge of the substrate with a lead pencil, marking pen, or small pieces of masking tape. NOTE: Do not use chalk line, china marker, or grease pencil. Safety decals will not adhere to these.
3. Remove the Liner
A small bend at the corner or edge will cause the liner to separate from the decal. Pull the liner away in a continuous motion at a 180-degree angle. If the liner is scored, bend at score and remove.
4. Apply Safety Decal
 - a. Tack decal in place with thumb pressure in upper corners.
 - b. Using firm initial squeegee pressure, begin at the center of the decal and work outward in all directions with overlapping strokes. NOTE: Keep squeegee blade even—nicked edges will leave application bubbles.
 - c. Pull up tack points before squeegeeing over them to avoid wrinkles.
5. Remove Pre-mask
If safety decal has a pre-mask cover remove it at this time by pulling it away from the decal at a 180 degree angle. NOTE: It is important that the pre-mask covering is removed before the decal is exposed to sunlight to avoid the pre-mask from permanently adhering to the decal.
6. Remove Air Pockets
Inspect the decal in the flat areas for bubbles. To eliminate the bubbles, puncture the decal at one end of the bubble with a pin (never a razor blade) and press out entrapped air with thumb moving toward the puncture.
7. Re-Squeegee All Edges.



SAFETY DECALS CONTINUED

**1. CAUTION: TO AVOID INJURY OR MACHINE DAMAGE:**

- Do not operate or work on this machine without reading and understanding the operator's manual.
- Keep hands, feet, hair and clothing away from moving parts.
- Do not allow riders on machine.
- Avoid unsafe operation or maintenance practices.
- Disengage power take-off and shut off engine before removing guards, servicing or unclogging machine.
- Keep unauthorized persons away from machine.
- Keep all guards in place when operating machine.
- If operator's manual is missing, contact your local New Leader dealer or print a new copy from www.highwayequipment.com.

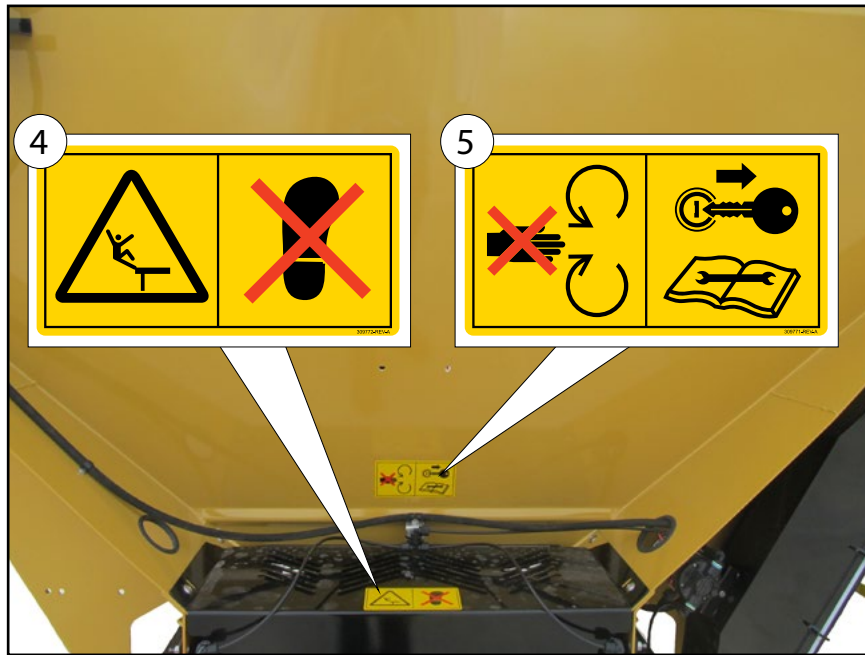
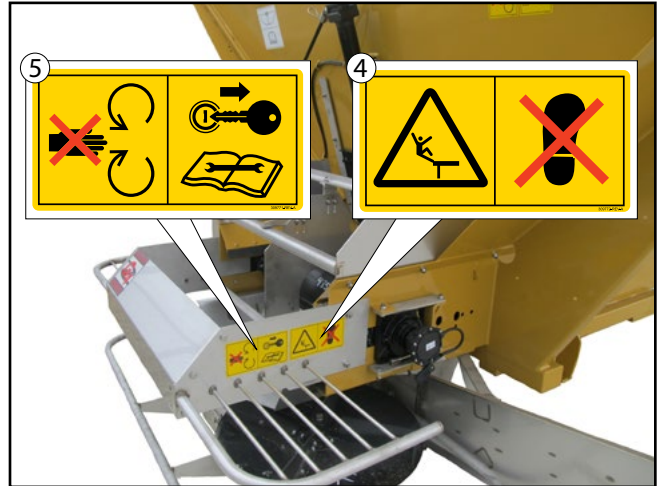
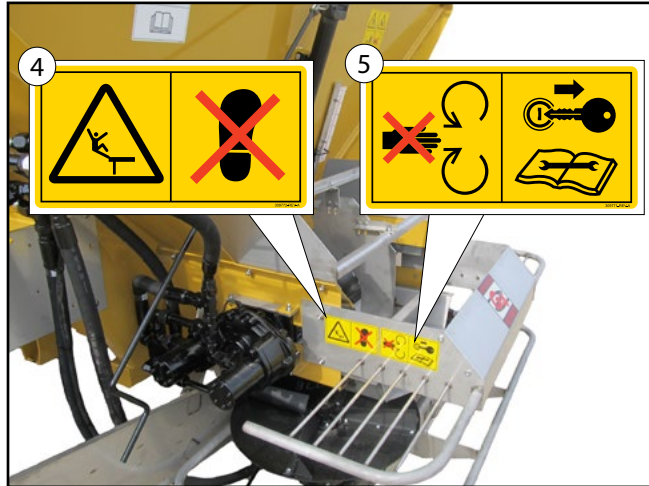
2. DANGER: MOVING PART HAZARD**To avoid death or serious injury:**

- Stay out of spreader while conveyor is moving.
- Disconnect and lock out power source before adjusting or servicing machine.
- Do not ride on the spreader.

3. CAUTION: HAZARDOUS MATERIALS**To avoid injury or machine damage:**

- Materials to be spread can be dangerous.
- Improper selection, application, use or handling may be hazardous to persons, animals, crops or other property.
- Follow all instructions and precautions given by material manufacturer.





4. WARNING: FALLING HAZARD

To prevent death, serious injury or machine damage:

- Do not climb or stand on guard.

5. WARNING: MOVING PART HAZARD

To avoid death, serious injury or machine damage:

- Close and secure all guards before operating machine.
- Do not stand or climb on machine.
- Shut off all power and remove key before adjusting or servicing machine.
- Keep hands, feet, hair and clothing away from moving parts.

SAFETY DECALS CONTINUED

**6. WARNING: HIGH-PRESSURE FLUIDS**

To avoid serious injury or machine damage:

- Inspect hoses periodically - at least once per year - for leakage, cuts, cracks, abrasions, kinking, corrosion, exposed wire braid or any other signs of damage or wear.
- Replace worn or damaged hose assemblies immediately with properly rated replacement parts.
- Escaping fluid under high pressure can penetrate the skin causing serious injury.
- Avoid hazards by relieving pressure before disconnecting hydraulic lines. Tighten all connections before running system.
- Search for leaks with a piece of cardboard. Protect hands and body from high-pressure fluids.
- If penetrated by high-pressure fluid, see a doctor immediately. Any fluid injected into the skin must be surgically removed within a few hours or gangrene may result.

7. WARNING: FALLING HAZARD

To prevent death, serious injury or machine damage:

- Do not place objects on fenders.
- Keep off of fenders. They are not intended to carry loads.

8. DANGER: MOVING PART HAZARD

To avoid death or serious injury:

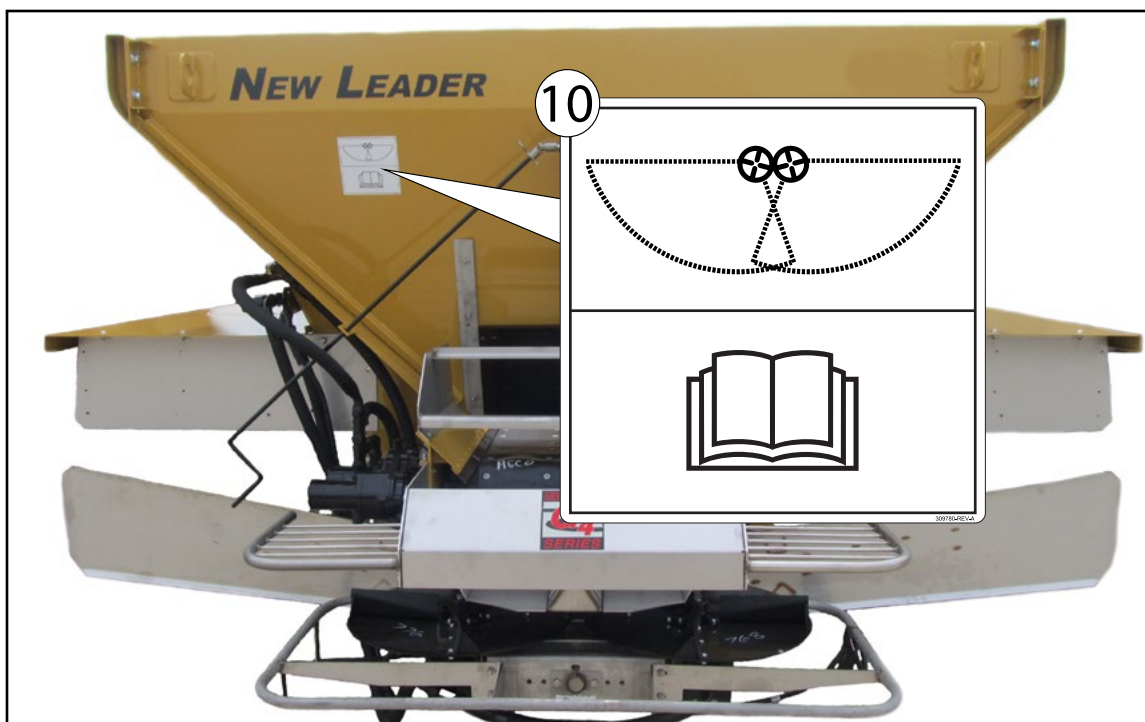
- Stay out of spreader while conveyor is moving.
- Shut off all power and remove key before adjusting or servicing machine.
- Do not ride on the spreader.



9. DANGER: FLYING MATERIAL AND ROTATING SPINNER HAZARD

To prevent death or serious injury:

- Wear eye protection.
- Stop machine before servicing or adjusting.
- Keep bystanders at least 60 feet away.



10. NOTICE: SPREAD PATTERN TESTING

To obtain optimal machine performance:

Before spreading material, spread pattern test must be conducted to properly adjust the spread pattern. Refer to the "Spread Pattern" section of this manual for adjustment instructions.

A spread pattern test kit is supplied with this spreader. Replacement kits are available from your local New Leader dealer.

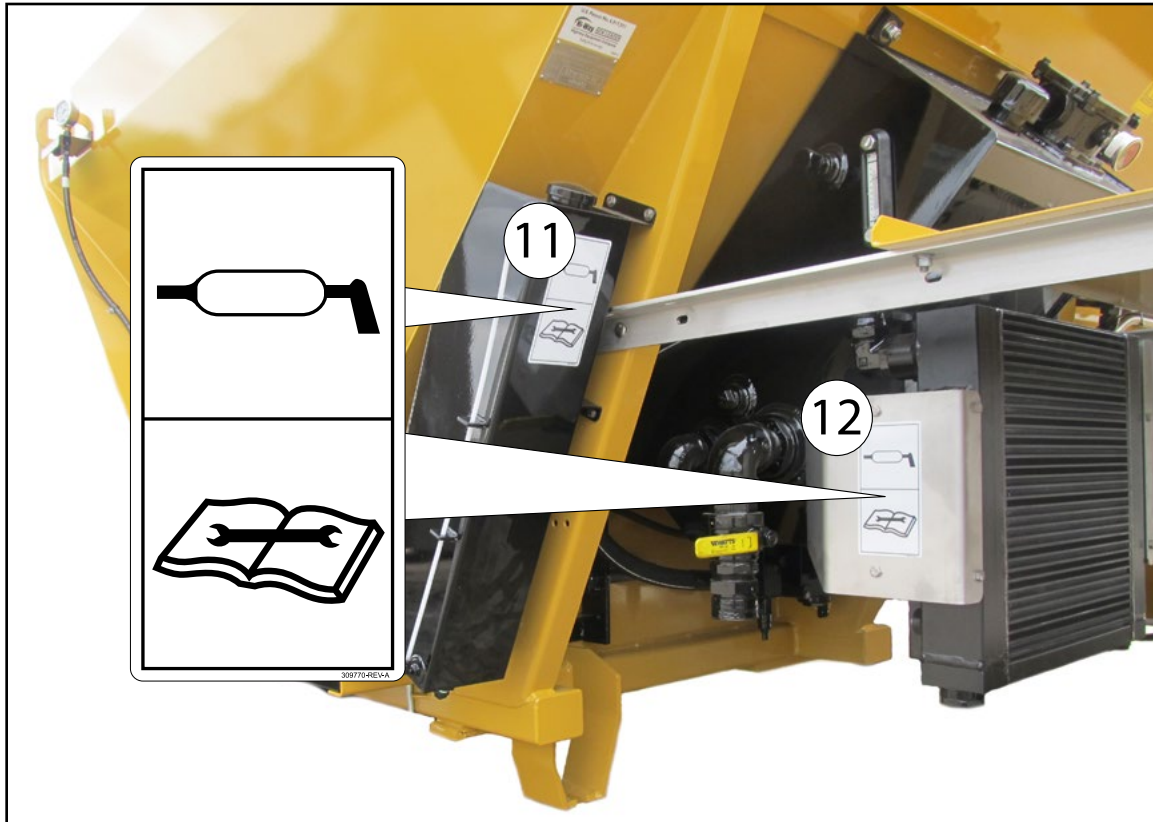
Wind, humidity, rain and other adverse weather conditions can affect spread pattern, resulting in uneven crop growth and loss of yields.

THE MANUFACTURER OF THIS SPREADER WILL NOT BE LIABLE FOR MISAPPLIED MATERIAL DUE TO AN IMPROPERLY ADJUSTED SPREADER OR ADVERSE WEATHER CONDITIONS.

It is recommended that a spread pattern test be conducted prior to each spreading season, after any spreader maintenance, and periodically during spreading season. Spread pattern tests must be conducted whenever a new product is to be applied.

This unit is intended for dispensing micronutrients and seeds only - NOT HERBICIDES. The manufacturer is not liable for damage resulting from improper use.





11. NOTICE: CONVEYOR CHAIN LUBRICATION

To avoid machine damage and premature deterioration:

- Conveyor chain life will be noticeably extended by periodic lubrication.
- See “Lubrication & Hydraulic Oil Specifications” in this manual for details.
- Failure to keep the chain links loose and free running can result in severe damage to the conveyor chain, drag shaft, gearcase and body structure, and is cause for voiding the warranty.

12. NOTICE: HYDRAULIC RESERVOIR

To avoid machine damage:

- Change the filter element after the first 50 hours of operation, and every 250 hours thereafter.
- Keep all reservoir valves open while the pump is running.
- See “Lubricant & Hydraulic Oil Specifications” in this manual for ideal operating temperatures.

GENERAL SAFETY RULES-OPERATIONS

1. Before attempting to operate this unit, read and be sure you understand the operation and maintenance manual. Locate all controls and determine the use of each. Know what you are doing!



2. When leaving the unit unattended for any reason, be sure to:
 - a. Take power take-off out of gear.
 - b. Shut off conveyor and spinner drives.
 - c. Shut off vehicle engine and unit engine (if so equipped).
 - d. Place transmission of the vehicle in "neutral" or "park".
 - e. Set parking brake firmly.
 - f. Lock ignition and take keys with you.
 - g. Lock vehicle cab.
 - h. If on steep grade, block wheels.

These actions are recommended to avoid unauthorized use, runaway, vandalism, theft and unexpected operation during start-up.

3. Do not read, eat, talk on a mobile phone or take your attention away while operating the unit. Operating is a full-time job.

4. Stay out of the spreader. If it's necessary to enter the spreader, return to the shop, empty body, turn off all power, set vehicle brakes, lock engine starting switch and remove keys before entering.



Tag all controls to prohibit operation. Tags should be placed, and later removed, only by person working in the body.

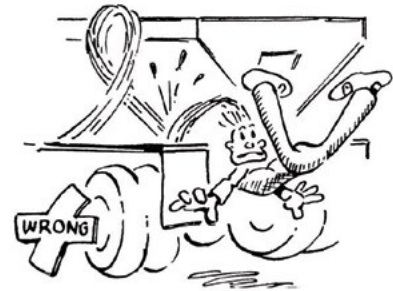
5. Guards and covers are provided to help avoid injury. Stop all machinery before removing them. Replace guards and covers before starting spreader operation.

6. Stay clear of any moving members, such as shafts, couplings and universal joints. Make adjustments in small steps, shutting down all motions for each adjustment.



7. Before starting unit, be sure everyone is clear and out of the way.

8. Do not climb on unit. Use the inspection ladder or a portable ladder to view the unit. Be careful in getting on and off the ladder, especially in wet, icy, snowy or muddy conditions. Clean mud, snow or ice from steps and footwear.



9. Do not allow anyone to ride on any part of unit for any reason.



10. Keep away from spinners while they are turning:
 - a. Serious injury can occur if spinners touch you.



- b. Rocks, scrap metal or other material can be thrown off the spinner violently. Stay out of discharge area.
- c. Make sure discharge area is clear before spreading.

11. Inspect spinner fins, spinner frame mounting and spinner fin nuts and screws every day. Look for missing fasteners, looseness, wear and cracks. Replace immediately if required. Use only new SAE grade 5 or grade 8 screws and new self-locking nuts.

12. Inspect all bolts, screws, fasteners, keys, chain drives, body mountings and other attachments periodically. Replace any missing or damaged parts with proper specification items. Tighten all bolts, nuts and screws to specified torques according to the torque chart in this manual.



13. Shut off engine before filling fuel and oil tanks. Do not allow overflow. Wipe up all spills. Do not smoke. Stay away from open flame. FIRE HAZARD!



14. Starting fluids and sprays are extremely flammable. Don't smoke. Stay away from flame or heat!




15. All vehicles should be equipped with a serviceable fire extinguisher of 5 BC rating or larger.



16. Hydraulic system and oil can get hot enough to cause burns. DO NOT work on system that is hot. Wait until oil has cooled. If an accident occurs, seek immediate medical assistance.

- 17. Wear eye protection while working around or on unit.
- 18. Read, understand and follow instructions and precautions given by the manufacturer or supplier of materials to be spread. Improper selection, application, use or handling may be hazardous to people, animals, plants, crops or other property.

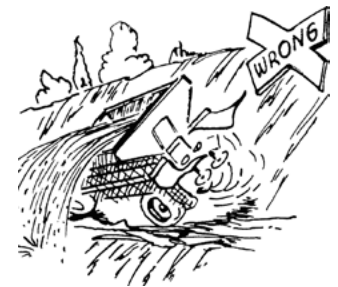


CAUTION If spreader is used to transport chemicals, check with your chemical supplier regarding DOT (Department of Transportation) requirements.

19. Cover all loads that can spill or blow away. Do



not spread dusty materials where dust may create pollution or a traffic visibility problem.



20. Turn slowly and be careful when traveling on rough surfaces and side slopes, especially with a loaded spreader. Load may shift causing unit to tip.

21. Read and understand the precautionary decals on the spreader. Replace any that become defaced, damaged, lost or painted over. Replacement decals can be ordered from your dealer's parts department or from Highway Equipment Company by calling (319) 363-8281.

GENERAL SAFETY RULES-MAINTENANCE

1. Maintenance includes all lubrication, inspection, adjustments (other than operational control adjustments such as feedgate openings, conveyor speed, etc.) part replacement, repairs and such upkeep tasks as cleaning and painting.



2. When performing any maintenance work, wear proper protective equipment—always wear eye protection—safety shoes can help save your toes—gloves will help protect your hands against cuts, bruises, abrasions and from minor burns—a hard hat is better than a sore head!

3. Use proper tools for the job required. Use of improper tools (such as a screwdriver instead of a pry bar, a pair of pliers instead of a wrench, a wrench instead of a hammer) not only can damage the equipment being worked on, but can lead to serious injuries. USE THE PROPER TOOLS.



4. Before attempting any maintenance work (including lubrication), shut off power completely. DO NOT WORK ON RUNNING MACHINERY!
5. When guards and covers are removed for any maintenance, be sure that such guards are reinstalled before unit is put back into operation.
6. Check all screws, bolts and nuts for proper torques before placing equipment back in service. Refer to torque chart in this manual.

7. Some parts and assemblies are quite heavy. Before attempting to unfasten any heavy part or assembly, arrange to support it by means of a hoist, by blocking or by use of an adequate arrangement to prevent it from falling, tipping, swinging or moving in any manner which may damage it or injure someone. Always use lifting device that is properly rated to lift the equipment. Do not lift loaded spreader. NEVER LIFT EQUIPMENT OVER PEOPLE.



8. If repairs require use of a torch or electric welder, be sure that all flammable and combustible materials are removed. Fuel or oil reservoirs must be emptied, steam cleaned and filled with water before attempting to cut or weld them. DO NOT weld or flame cut on any tank containing oil, gasoline or their fumes or other flammable material, or any container whose contents or previous contents are unknown.
9. Keep a fully charged fire extinguisher readily available at all times. It should be a Type ABC or a Type BC unit.
10. Cleaning solvents should be used with care. Petroleum based solvents are flammable and present a fire hazard. Don't use gasoline. All solvents must be used with adequate ventilation, as their vapors should not be inhaled.



11. When batteries are being charged or discharged, they generate hydrogen and oxygen gases. This combination of gases is highly explosive. **DO NOT SMOKE** around batteries—**STAY AWAY FROM FLAME**—don't check batteries by shorting terminals as the spark could cause an explosion. Connect and disconnect battery charger leads only when charger is "off". Be very careful with "jumper" cables.



12. Batteries contain strong sulfuric acid—handle with care. If acid gets on you, flush it off with large amounts of water. If it gets in your eyes, flush it out with plenty of water immediately and get medical help.

13. Hydraulic fluid under high pressure leaking from a pin hole are dangerous as they can penetrate the skin as though injected with a hypodermic needle. Such liquids have a poisonous effect and can cause serious wounds. To avoid hazard, relieve pressure before disconnecting hydraulic lines or performing work on system. Any fluid injected into the skin must be treated within a few hours as gangrene may result. Get medical assistance immediately if such a wound occurs. To check for such leaks, use a piece of cardboard or wood instead of your hand. Make sure all hydraulic fluid connections are tight and all hydraulic hoses and lines are in good condition before applying pressure to system. Wear protective gloves and safety glasses or goggles when working with hydraulic systems.



14. The fine spray from a small hydraulic oil leak can be highly explosive—**DO NOT SMOKE**—**STAY AWAY FROM FLAME OR SPARKS**.

GENERAL SAFETY RULES-INSTALLATION

1. The selection of the vehicle on which a spreader body is to be mounted has important safety aspects. To avoid overloading:
 - a. Do not mount spreader on a chassis which, when fully loaded with material to be spread, will exceed either the Gross Axle Weight Rating (GAWR) or the Gross Vehicle Weight Rating (GVWR) for the chassis.
 - b. Do install the spreader only on a vehicle with cab-to-axle dimension recommended for the spreader body length shown.



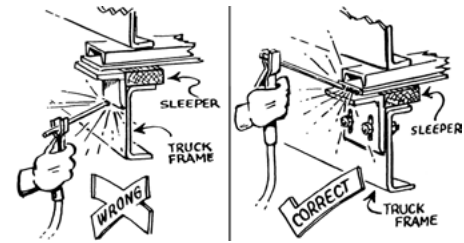
2. Follow mounting instructions in the Installation section of this manual. If mounting conditions require deviation from these instructions refer to factory.
3. When making the installation, be sure that the lighting meets Federal Motor Vehicle Safety Standard (FMVSS) No. 108, ASABE S279 and all applicable local and state regulations.
4. When selecting a PTO to drive hydraulic pump, do not use a higher percent speed drive than indicated in the Installation section of this manual. Too high a percent PTO will drive pump at excessive speed, which can ruin the pump, but more importantly, will overheat the hydraulic oil system and increase the possibility of fire.



5. When truck frame must be shortened, cut off only the portion that extends behind rear shackle in accordance with the truck manufacturer's recommendations. If a torch is used to make

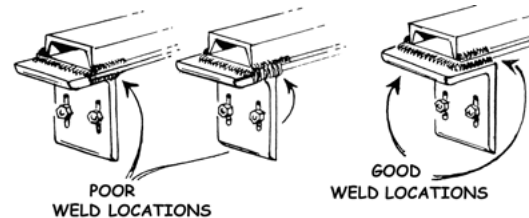
the cut, all necessary precautions should be taken to prevent fire. Cuts should not be made near fuel tanks and hydraulic oil reservoirs, fuel, brake, electric or hydraulic lines and such lines should be protected from flame, sparks or molten metal. Tires should be removed if there is any chance of their being struck by flame, sparks or molten metal. Have a fire extinguisher handy.

6. Do not weld on vehicle frame as such welding can lead to fatigue cracking



and must be avoided. When drilling holes in frame member, drill only through the vertical web portions do not put holes in top or bottom flanges. Refer to truck manufacturer's recommendations.

7. Be sure that welds between mounting bars and sill or between mounting angles and spreader cross sills are sound, full fillet welds. Center mounting angles so that good fillet welds can be made on three sides—an edge bead weld is not a satisfactory weld for this service. Use 309 rod/wire for carbon steel and 409 steel. On 304 stainless steel bodies use SAE grade 8 bolts—welding is recommended if type 308 welding rod is available.



8. Install controls so that they are located of convenient use. Position them so that they do not interfere with any vehicle control and that they do not interfere with driver or passenger or with access to or exit from the vehicle.
9. Check for vehicle visibility, especially toward the rear. Reposition or add mirrors so that adequate rearward visibility is maintained.
10. Add Caution, Warning, Danger and Instruction decals as required. Peel off any label masking which has not been removed.
11. Install all guards as required.
12. Check installation completely to be sure all fasteners are secure and that nothing has been left undone.

LIFTING THE SPREADER**WARNING**

Use only lifting devices that meet or exceed OSHA standard 1910.84 or ASME B30.20-2006. Never lift equipment over people. Never lift unit with anything or anybody in the body. Loads may shift or fall if improperly supported, causing damage to unit, injury or even death.

**CAUTION**

Do not use lifting device to free unit from a chassis, storage stands or frozen ground, or to lift the chassis in any way. Shock loading is prohibited and sudden accelerations should be avoided. Lifting in such a manner could result in damage to unit or injury.

Always inspect unit lift points for signs of wear, cracking, corrosion, gouges, alterations, or distortion.

Always use a sling, spreader bar, or lifting bar that attaches to the lifting points with a minimum of 60 degrees from horizontal. It is preferable to use an "H" style lifting bar that keeps the attaching chains in a near vertical orientation as shown in Figure 1. Operators of lifting devices must be qualified and knowledgeable in their use and application.

Position the chassis with adequate room around the unit. Work in an environment that permits clear communication to others nearby. Keep area clear of persons when loads are to be lifted and suspended. Do not allow the lifted load to come in contact with any obstruction.

Store units on a solid surface using appropriate storage stands when not installed.

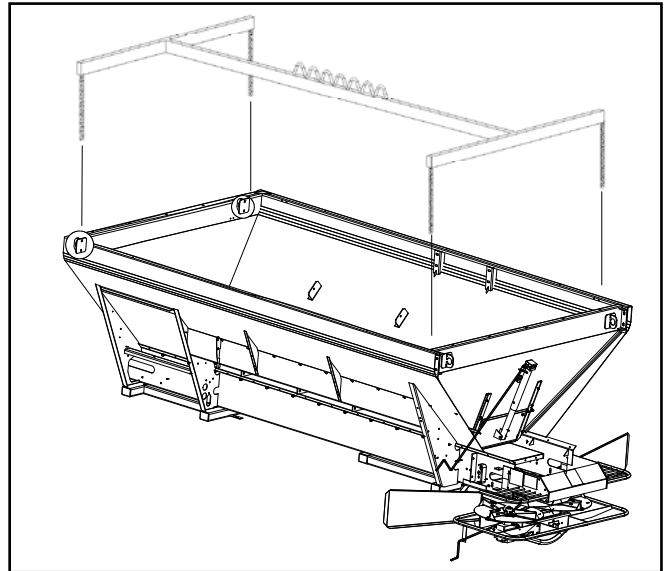


Figure 1 - Lifting Bar

SIDE BOARD INSTALLATION

NOTICE! Sideboards are for use with fertilizer only.

See "Side Boards" parts list in the parts manual for availability and illustrations.

HYDRAULIC HOSE INSTALLATION

**CAUTION**

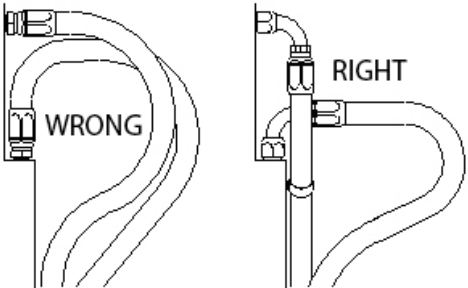
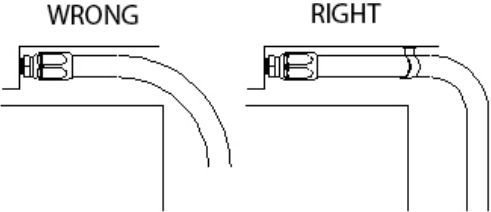
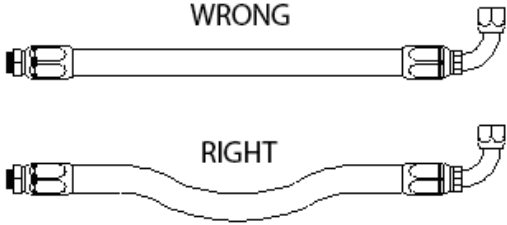
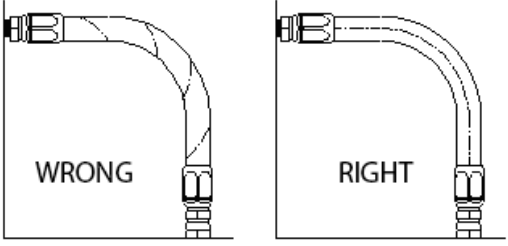
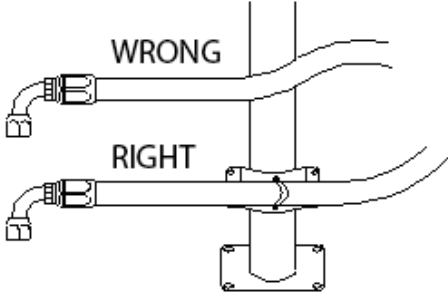
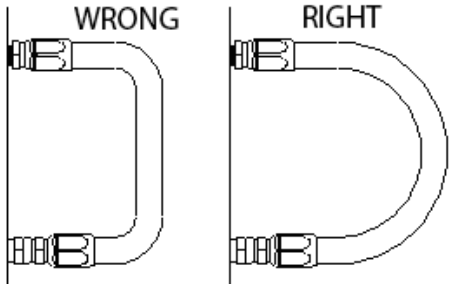
If a threaded connection is tightened too tightly, the fitting or housing into which the fitting is placed could be distorted and an unstoppable leak could occur.

**WARNING**

Do not use one manufacturer's hose with another manufacturer's fittings! Such will void any warranty and may cause premature burst or leak of hydraulic fluids! Severe injury and/or fire could result!

Determine pressure port of pump. Install pressure hose into this port as shown in Figure 7. Connect suction hose to opposite port and to tank outlet on hydraulic tank. Use plastic tie straps as necessary to support hoses so they will not catch on field obstructions or contact hot or moving parts.

INSTALLATION GUIDE

	
<p>1. Use elbows and adapters in the installation to relieve strain on the assembly, and to provide easier and neater installations that are accessible for inspection and maintenance. Remember that metal end fittings cannot be considered as part of the flexible portion of the assembly.</p>	<p>2. Install hose runs to avoid rubbing or abrasion. Clamps are often needed to support long runs of hose or to keep hose away from moving parts. It is important that the clamps be of the correct size. A clamp that is too large will allow the hose to move in the clamp causing abrasion at this point.</p>
	
<p>3. In straight hose installations allow enough slack in the hose line to provide for changes in length that will occur when pressure is applied. This change in length can be from +2% to -4%.</p>	<p>4. Do not twist hose during installation. This can be determined by the printed layline on the hose. Pressure applied to a twisted hose can cause hose failure or loosening of the connections.</p>
	
<p>5. Keep hose away from hot parts. High ambient temperature will shorten hose life. If you cannot route it away from the heat source, insulate it.</p>	<p>6. Keep the bend radii of the hose as large as possible to avoid hose collapsing and restriction of flow. Follow catalog specs on minimum bend radii.</p>

(Used with the permission of The Weatherhead Company.)

FILLING HYDRAULIC SYSTEM**NOTICE!**

DO NOT attempt to run pump without first filling hydraulic oil tank and opening suction line valve, or damage to pump may occur.

Fill hydraulic reservoir with hydraulic oil as specified in the "Lubrication and Maintenance" section in the operator's manual. Be sure oil is clean, free from dirt, water and other contaminants.

Lubricate all points necessary per Lubrication Chart in "Lubrication and Maintenance" section of operator's manual.

Recommended sequence of installation is:

1. Spreader preparation.
2. Insert preparation.
3. Mounting of insert.
4. Connecting hydraulic hoses.
5. Installation of hillside divider and conveyor cover.
6. Checking installation.
7. Checking for leaks and proper functioning.

SPREADER PREPARATION



WARNING

Use only lifting devices that meet or exceed OSHA standard 1910.184. Never exceed work load limits or lift equipment over people. Empty spreader before lifting. Loads may shift or fall if improperly supported, causing injury.

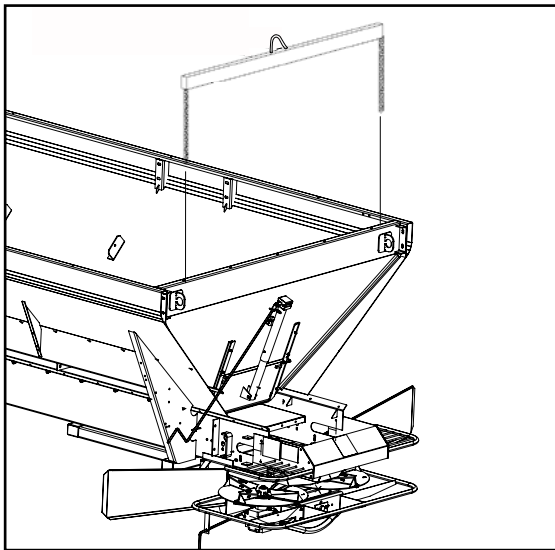


Figure 1

Remove the Inverted "V" and Hillside Divider from the spreader, if so equipped, and set hardware aside.

Remove Feedgate Jack Handle and set aside. Support endgate by attaching a hoist to the lift hooks. Remove hardware from both sides of the endgate and carefully remove from the spreader as shown in Figure 1.

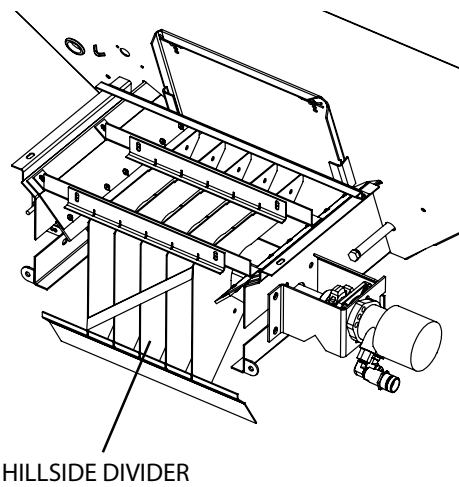
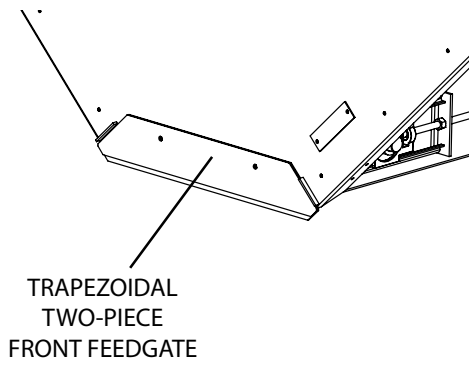
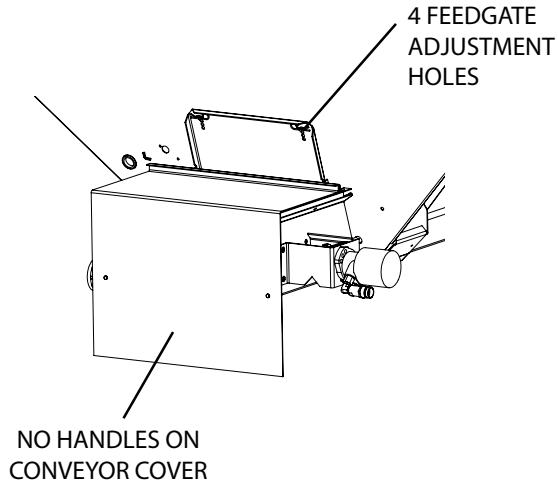
NOTE: Always use a sling, spreader bar, or lifting bar that attaches to the lifting points with a minimum of 60 degrees from horizontal. It is preferable to use a straight style lifting bar that keeps the attaching chains in a near vertical orientation.

NOTE: Always inspect unit lift hooks for signs of wear, cracking, corrosion, gouges, alterations, or distortion before use.

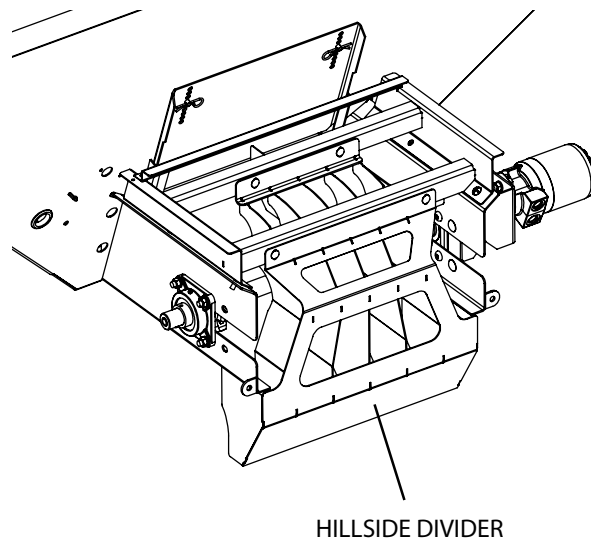
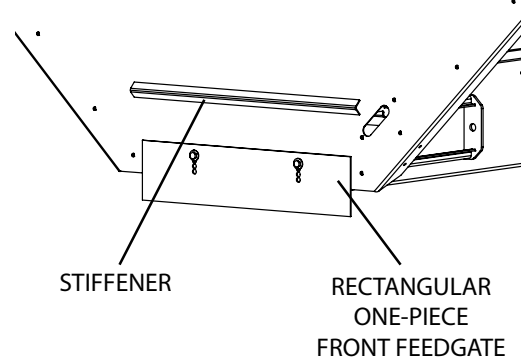
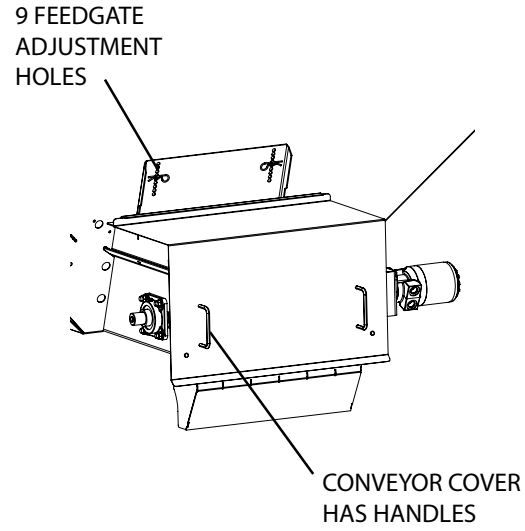
NOTICE!

The MULTAPPLIER is available in two different styles; Style I and Style II. The Style II MULTAPPLIER provides higher output capabilities. Refer to next page to determine your style of MULTAPPLIER insert.

Style I



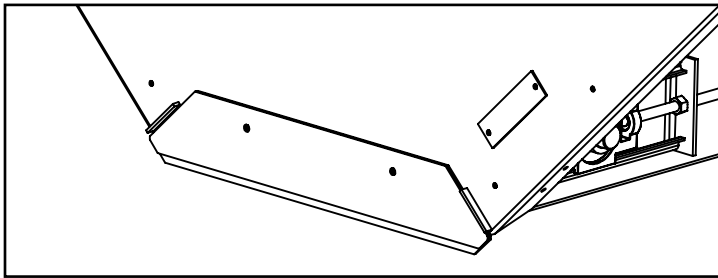
Style II



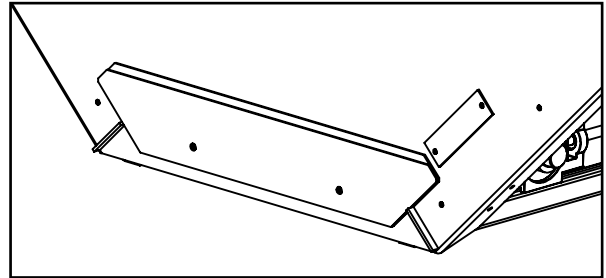
FEEDGATE ADJUSTMENT**WARNING**

Stay out of the spreader. If it's necessary to enter the spreader, return to the shop, empty body, turn off all power, set vehicle brakes, lock engine starting switch and remove keys before entering. Tag all controls to prohibit operation. Tags should be placed, and later removed, only by person working in the body.

Adjust the insert's front feedgate prior to installation.

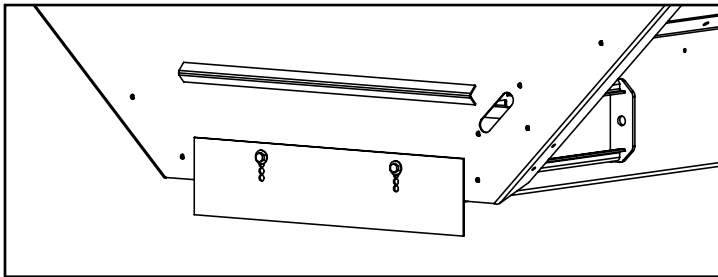


**Figure 2A - 1 1/2" (3.81 cm) or 2" (5.08 cm) Opening
(Style I MULTAPPLIER)**

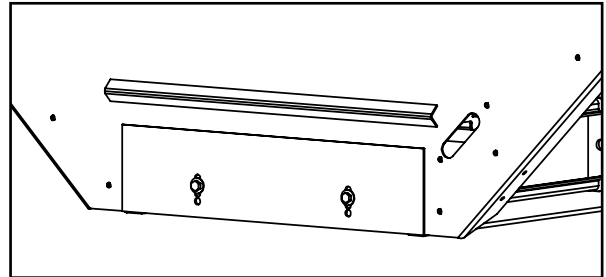


**Figure 2B - 3" (7.62 cm) Opening
(Style I MULTAPPLIER)**

Style I MULTAPPLIER - To adjust main bin's feedgate opening on a Style I MULTAPPLIER-equipped unit: position front feedgates on MULTAPPLIER as necessary to achieve a 1-1/2 inch (3.81 cm), 2 inch (5.08 cm) (Figure 2A) or 3 inch (7.62 cm) (Figure 2B) opening. Position both feedgates with short side down for a 3" (7.62 cm) opening. NOTE: Both feedgates are installed for shipping.



**Figure 3A - 2 1/2" (3.81 cm) or 2" (5.08 cm) Opening
(Style II MULTAPPLIER/MULTIBIN)**



**Figure 3B - 4" (10.16 cm) Opening
(Style II MULTAPPLIER/ MULTIBIN)**

Style II MULTAPPLIER/MULTIBIN - To adjust main bin's feedgate opening on a Style II MULTAPPLIER or MULTIBIN-equipped unit: position front feedgate on MULTAPPLIER as necessary to achieve a 1 1/2 inch (3.81 cm) (Figure 3A) to 4 inch (10.16 cm) (Figure 3B) opening in 1/2 inch increments.

NOTE:

Visit www.newleadervip.com and enter parameters to determine minimum and maximum application rates and feedgate openings for optimal performance of your spreader.

1. Make sure rubber sealer hardware is loose. If not, loosen.



Figure 4A



Figure 4B

2. To install insert:
 - a. Figure 4A - Hoist insert into position and slide between main bin's side sheets.
 - b. Figure 4B - Align insert's and main bin's front and rear mount brackets.
 - c. Make sure insert is resting on inside of main bin, and not resting on tops of side sheets.
 - d. Release tension on hoist but do not remove.



Figure 5A (uninstalled)

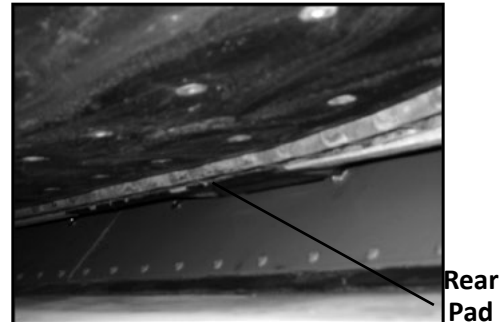


Figure 5B (shown installed)
View from rear of unit.

3. Figures 5A-5B - Visually make sure insert is centered from side to side in main bin and rear pads are resting on main bin.

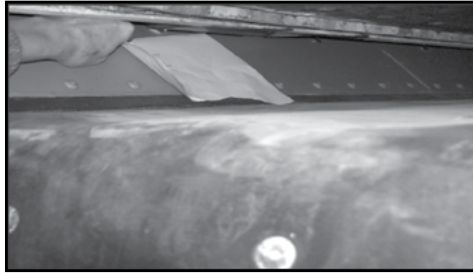


Figure 6



Figure 7

4. Figure 6 - There must be contact between rear pads and main unit. Check for contact by trying to slide paper between pads and main bin. If no contact, adjust insert.
5. Figure 7 - Inside main unit, locate front pads by lifting rubber sealers on front endgate.

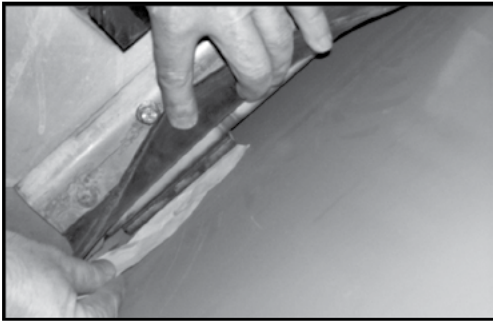


Figure 8A

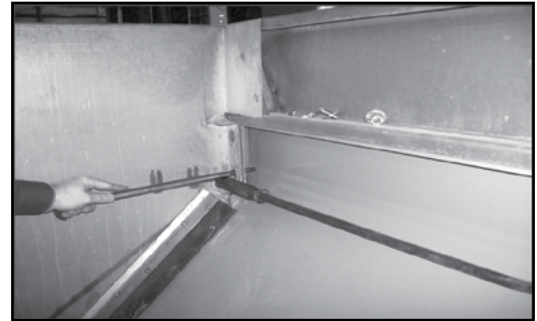


Figure 8B

6. Figures 8A-8B - There must be contact between front pads and main bin. Check for contact by trying to slide paper between pads and main bin. If no contact, adjust insert.
NOTE: Pry insert at mount brackets if necessary.



Figure 9



Figure 10



Figure 11

7. Figure 9 - Once both front pads make contact, insert hardware in front mount brackets' lower holes. Shim between main bin and MULTAPPLIER/MULTIBIN brackets if distance is larger than 1/8" (.32cm). Tighten hardware per torque recommendations in this manual.
8. Figure 10 - Make sure front feedgate is level. Lower endgate sealers so flush with chain shields and tighten hardware.

NOTICE!

Leakage of material may occur if the sealer belts are not set properly on the front of the MULTIBIN. Highway Equipment Company is not liable for lost material due to improperly installed sealer belts.

9. Figure 11 - Make sure there is a complete seal covering the gap between the insert and the main bin's side sheets. Tighten all hardware on rubber sealers at front of MULTAPPLIER/MULTIBIN.
10. Make sure rear pads are still in place against main bin. Install hardware in lower holes of rear mount brackets. Shim between main bin and insert brackets if distance is larger than 1/8" (.32cm). Tighten hardware per torque recommendations in this manual.
11. Make sure MULTAPPLIER/MULTIBIN's side sheets are not resting on top of main bin's side sheets.
12. Install hardware in all four mount brackets' upper holes. Tighten hardware per torque recommendations.
13. Remove hoist.
14. Inspect unit for foreign debris in conveyor area.
15. MULTIBIN only - Inspect unit for foreign debris in meter wheel area.

LOWER DIVIDER - MULTIBIN

The following steps apply to MULTIBIN units only. Continue to "Hydraulics" for MULTAPPLIER units.

NOTICE! Highway Equipment Company will not be liable for misapplied material due to an improperly adjusted divider, spreader or both.

Parts Needed:

<u>Description</u>	<u>Qty</u>
Divider - Lower Weldment	1
Capscrew - 5/16 x 1	4
Washer - Flat 5/16	8
Nut - Lock 5/16 SS	4

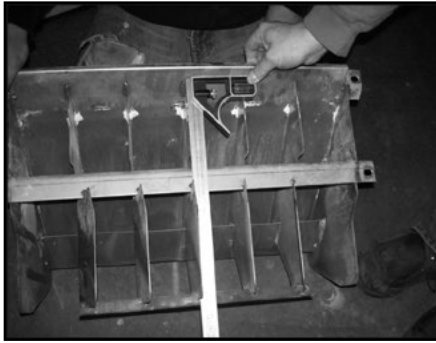


Figure 12

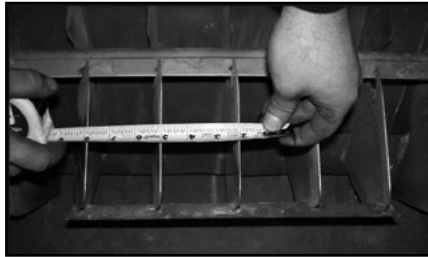


Figure 13



Figure 14

1. Figure 12 - Make sure center fin is square to rear panel.
2. Figure 13 - Measure distance between Lower Divider fins to make sure they are all 3" (8cm) apart. Adjust top of fin as necessary.
3. Figure 14 - Slide Lower Divider between bottom of MULTIBIN and Spinner Divider as shown.



Figure 15

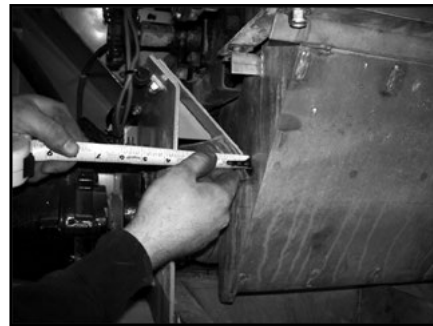


Figure 16

4. Figure 15 - Lift Lower Divider to bottom of MULTIBIN, align holes and loosely install front and rear hardware.
5. Figure 16 - Verify Lower Divider is square by measuring from each side to main bin's chain shields. Make sure distances are equal.

6. Make sure Lower Divider is centered over Material Divider. Contact Highway Equipment Company if they cannot be aligned.
7. Tighten front and rear hardware per torque recommendations. Refer to "Standard Torques" in the "Lubrication and Maintenance" section of the spreader manual.

HYDRAULICS

Attach insert hoses to spreader hoses as shown in Figures 17A - 17C as applicable. Plug in rate sensor.

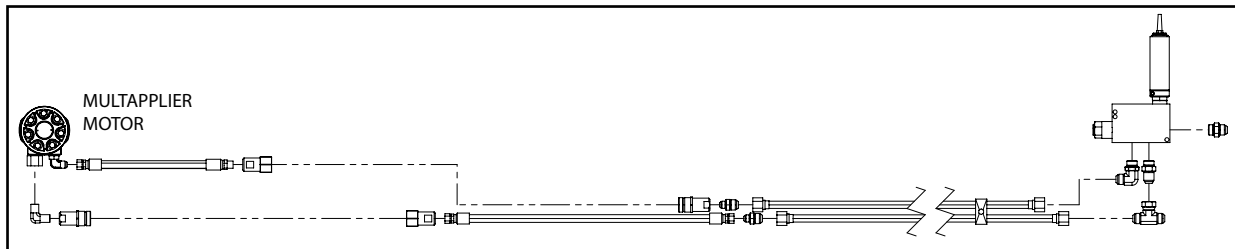


Figure 17A - MULTAPPLIER Operation

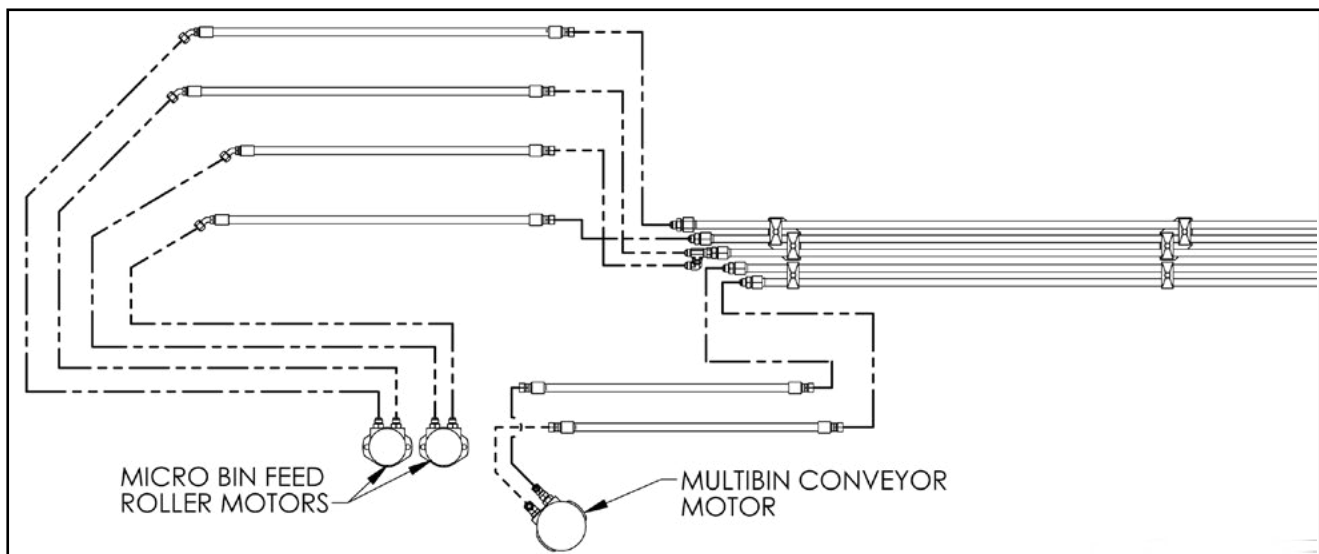


Figure 17B - MULTIBIN Operation Dual Micro

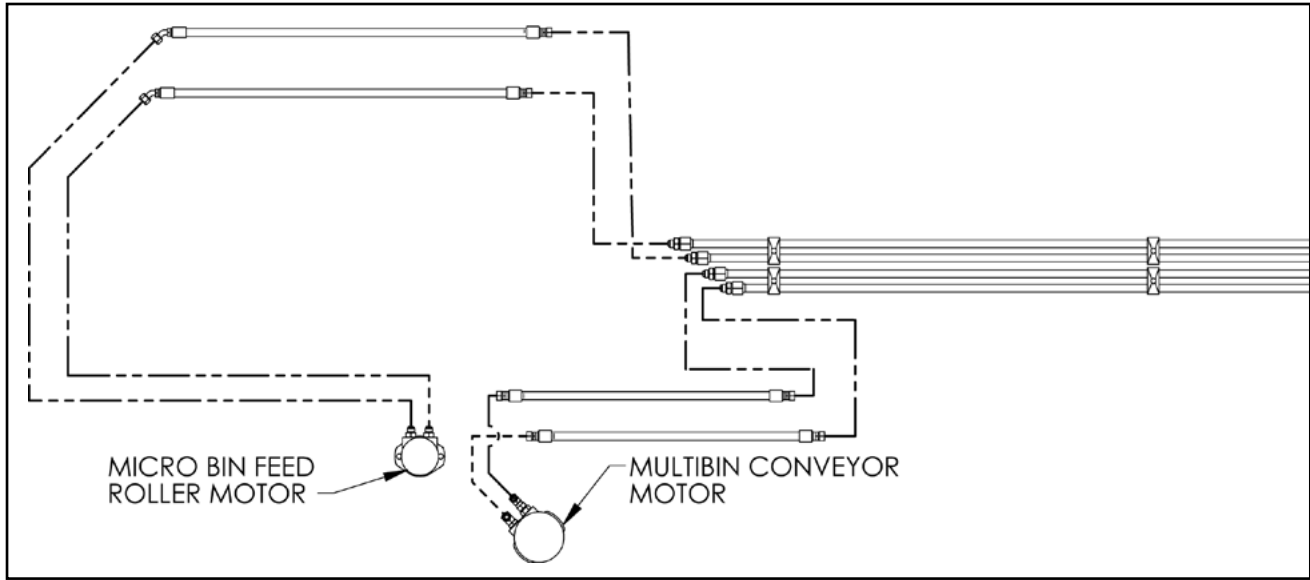


Figure 17C – MULTIBIN Operation Single Micro

HYDRAULIC HOSE INSTALLATION

Refer to “Installation Guide” for proper hydraulic hose installation guidelines.

If insert was purchased separately from spreader, refer to parts pages for hydraulic installation. Install valve mounting bracket on two right hand front stakes as shown in Figure 18 (MULTIBIN installation shown).

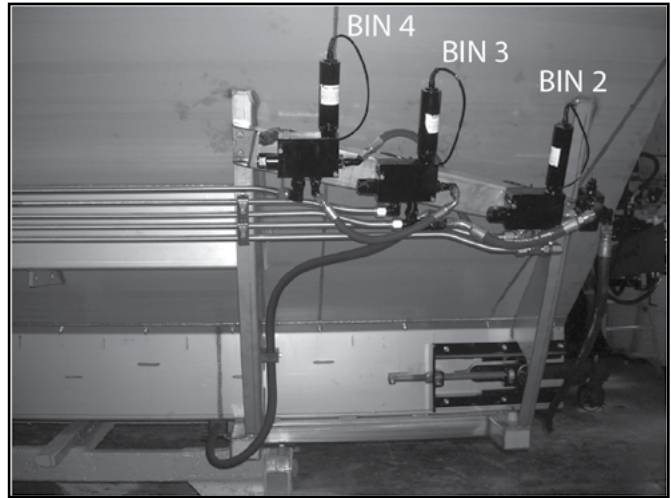


Figure 18 - Hydraulic Installation

HILLSIDE DIVIDER & CONVEYOR COVER - MULTAPPLIER

The following steps apply to MULTAPPLIER units only. Continue to “Micro Cover Installation” for MULTIBIN units.

NOTICE!

Highway Equipment Company will not be liable for misapplied material due to an improperly adjusted divider, spreader or both.

NOTICE!

Highway Equipment Company will not be liable for misapplied material due to an improperly adjusted divider, spreader or both.



Figure 19A - MULTAPPLIER Hillside Divider (Style I)

Style I MULTAPPLIER - Remove hardware from rear two chain shield holes on each side of MULTAPPLIER and set aside. Install MULTAPPLIER Hillside Divider (A) over conveyors and attach using chain shield hardware. Adjust Hillside Divider so that the middle divider is centered over both conveyors and the Material Divider (B) as shown in Figure 19A. Tighten hardware to recommended torque.

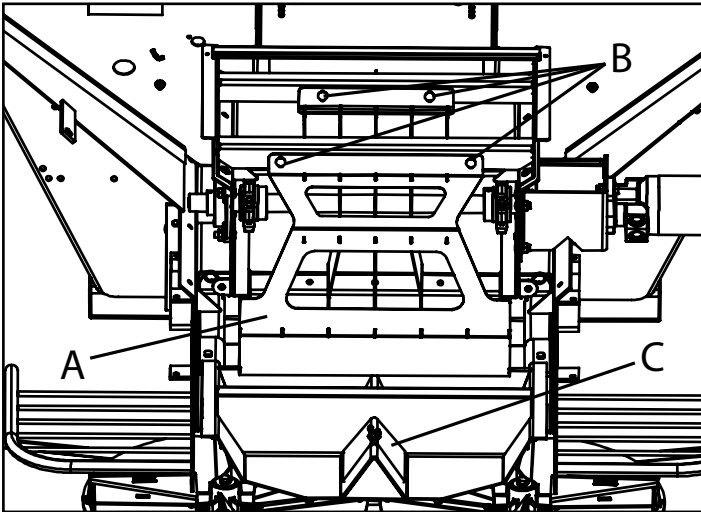


Figure 19B - MULTAPPLIER Hillside Divider (Style II)

Style II MULTAPPLIER - Loosen hardware from rear two chain shield holes on each side of MULTAPPLIER. Install MULTAPPLIER Hillside Divider (A) and fasten to Support using single bin Hillside Divider hardware removed before MULTAPPLIER installation (B). Adjust Hillside Divider so that the middle divider is centered over both conveyors and the Material Divider (C) as shown in Figure 19B. Tighten all hardware to recommended torque.

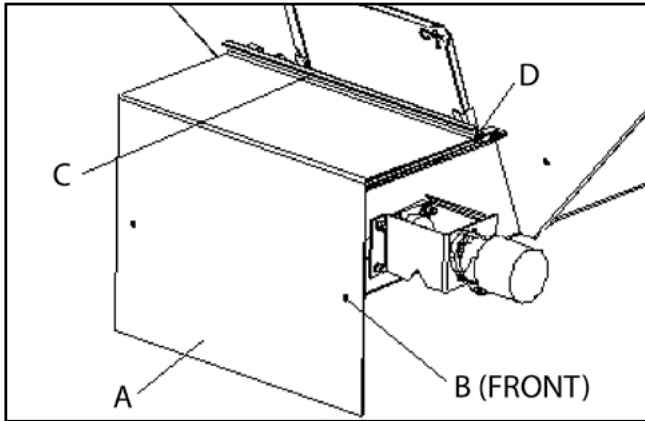


Figure 20A - Dual Conveyor Cover (Style I MULTAPPLIER)

Parts Needed:

<u>Description</u>	<u>Qty</u>
Cover	1
Hold-down	1
Hair Pin	2
Capscrew - 3/8 x 1	6
Flat Washer - 3/8	6
Lock Washer - 3/8	6
Hex Nut - 3/8	8

Style I MULTAPPLIER - Remove rear plate of Material Divider. Place Cover (A) on MULTAPPLIER sills as shown in Figure 20A and insert hair pins (B) through cover pins. Position Hold-down (C) over Cover and attach with supplied hardware (D). Reinstall rear plate of Material Divider.

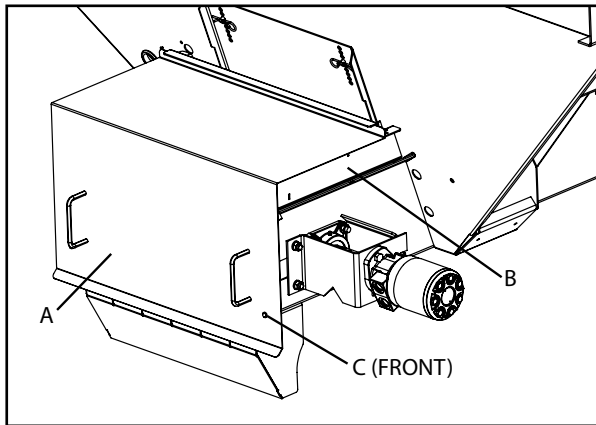


Figure 20B - Dual Conveyor Cover (Style II MULTAPPLIER)

Parts Needed:

<u>Description</u>	<u>Qty</u>
Cover	1
Hair Pin	2

Style II MULTAPPLIER - Remove rear plate of Material Divider. Place Cover (A) on Hillside Divider Support (B) as shown in Figure 20B and insert hair pins (C) through Cover pins. Reinstall rear plate of Material Divider.

MICRO COVER INSTALLATION

Air Supply and Electrical Requirements

Auxiliary Supply Line	Electrical Connections
Dry Air - 85 PSIG (5.86 Bar)	Red = 12 V (+) Black = Ground (-)

Refer to "MultiBin Lid Pneumatics" in the spreader parts manual for air line connections.

Make sure all hardware on insert is torqued before installing cover.

**WARNING**

Pressurized air may cause sudden movement of parts. Do not service cover components until safety precautions have been performed.

- Take preventative measures to prevent falling or runaway of cylinder or mechanism before maintenance and restart of spreader.
- Exhaust all residual air and cut the pressure supply for components before servicing.
- Injury can occur if precautions are not taken.

**WARNING**

Open cover lid with air prior to removing actuator pin and block cover lid to prevent closing. Unintentional closing could cause injury.

Fasten a three-point lifting device to two lift hooks and one hole in guide mount as shown in Figure 21. Hoist cover onto MULTIBIN as shown in Figure 22. Align slots and attach hardware. Tighten to recommended torque. Secure fittings and airline tubing on MULTIBIN with wire ties as shown in Figure 23. Connect to air and electrical systems. Open lid and install additional hardware inside cover. Install screens.

Refer to "Air Schematic" page in the *Troubleshooting* section for air supply requirements.

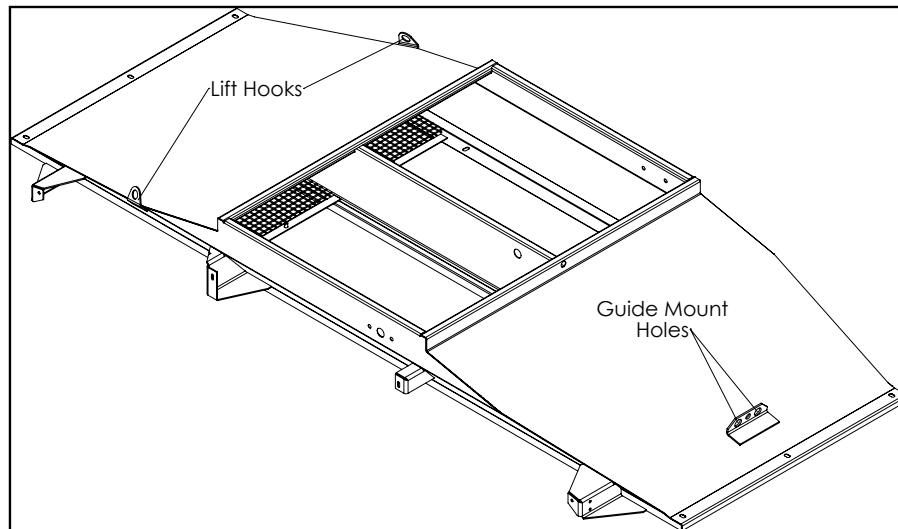


Figure 21 - Lift Hooks & Guide Mount

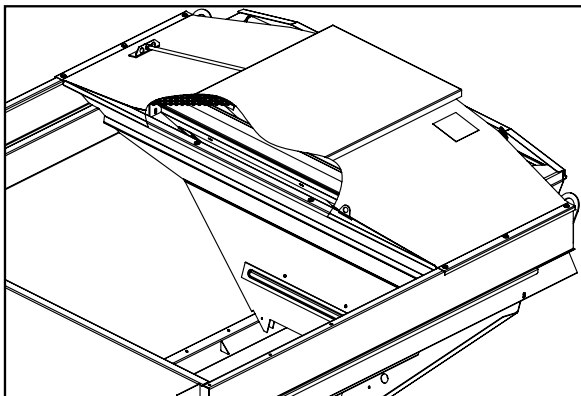


Figure 22 - Cover Placement

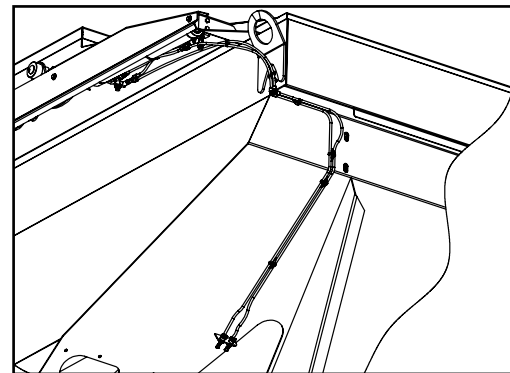


Figure 23 - Cover Airline Tubing

ELECTRICAL CONNECTIONS

Connect all electrical control circuits. The supply conductor should be connected directly to the battery. All wiring should be approved automotive insulated wire, supported adequately with insulating ties or straps, and located where it will not interfere with any control or access. Make sure wiring does not contact any moving parts or sharp edges and is kept away from hydraulic lines and heated parts.

INSERT REMOVAL/ENDGATE INSTALLATION

Remove insert and reinstall endgate, Inverted “V”, single conveyor Hillside Divider, etc. by following applicable installation instructions in reverse order. Make sure the insert hydraulics, electrical connections and air lines are disconnected from the spreader before removal. See “Inverted V” in spreader parts manual.

Hydraulics Removal

Route hydraulic hoses on the spreader and the insert as shown in Figures 24A - 24C as applicable.

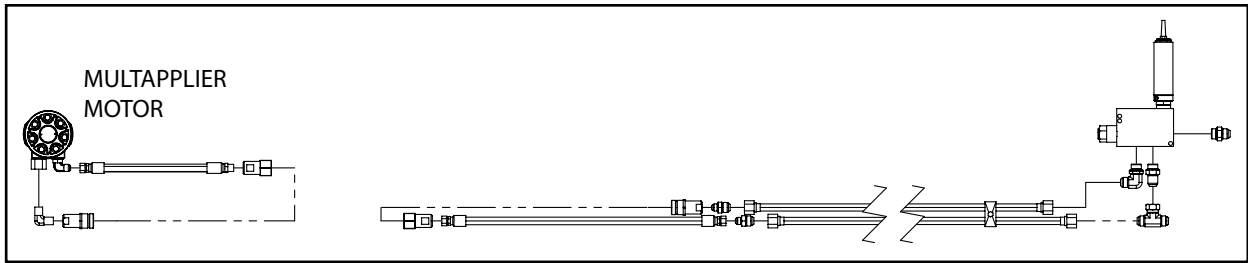


Figure 24A - Detach MULTAPPLIER

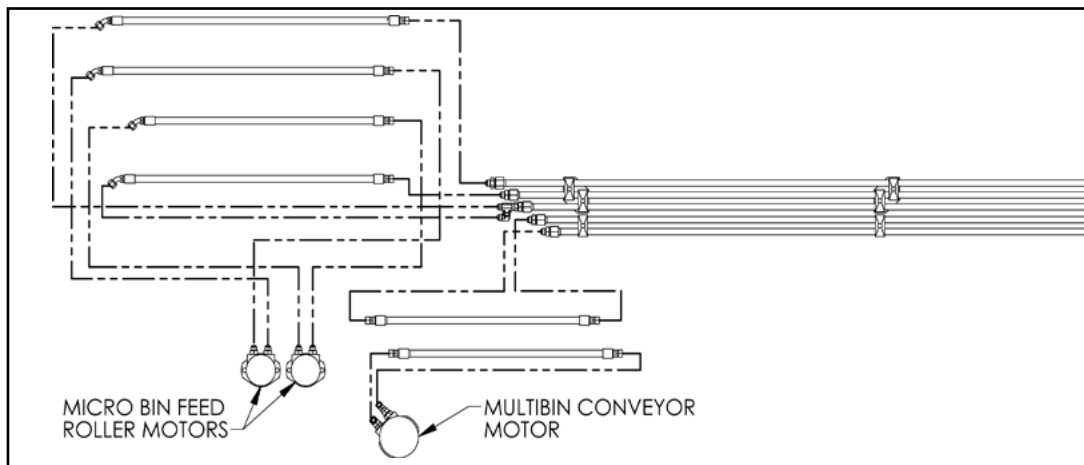


Figure 24B - Detach MULTIBIN Dual Micro

INSTALLATION

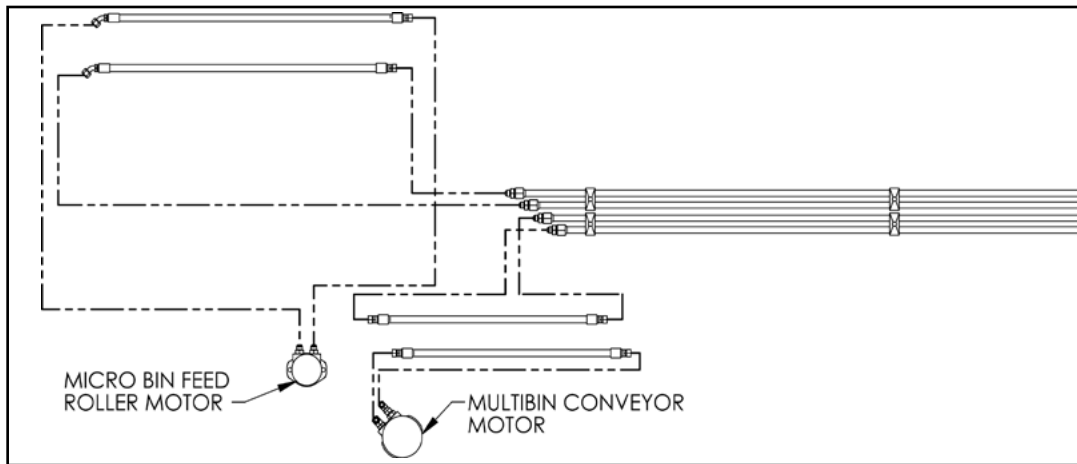


Figure 24C – Detach MULTIBIN Single Micro

INSTALLATION

The L4000G4 is a hopper type spreader intended for spreading free flowing granular agricultural materials, such as chemical fertilizers, agricultural limestone, and gypsum. It is intended for mounting on the Ag Chem TerraGator - a high flotation agricultural application vehicle.

The unit is powered hydraulically and provides variable speed control for the spinner and full automatic ground speed control for the conveyor.

The conveyor delivers material to the spinners through an adjustable metering gate at the rear of the hopper body. Orbital type hydraulic motors mounted to 6-to-1 ratio spur gear case drive the conveyor. The conveyor options include the #3 chain conveyr consisting of pintle type chain joined by cross bars every link, or the #4 belt-over-chain (BOC) type having parallel strands of pintle type chain joined by cross bars every other link. Moderately oil resistant (MOR) belting is fastened to the conveyor at every cross bar.

The spinner assembly has two 24-inch (61 cm) diameter dished discs. Each disc has four formed and heat-treated fins that are adjustable to radial angle. The spinner is fully adjustable by means of a rotating handle.

The optional 304 stainless steel hopper style spreader MULTAPPLIER or MULTIBIN may be insterted in the main bin.

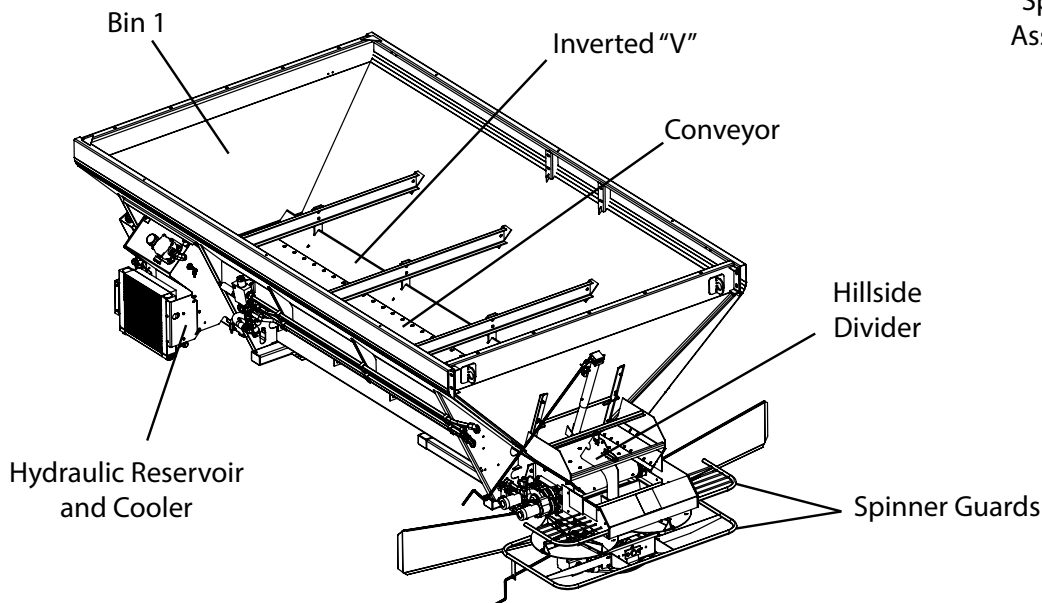
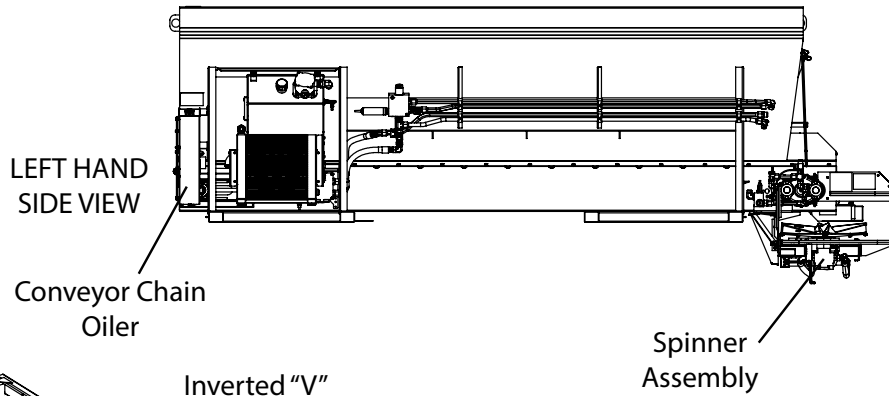
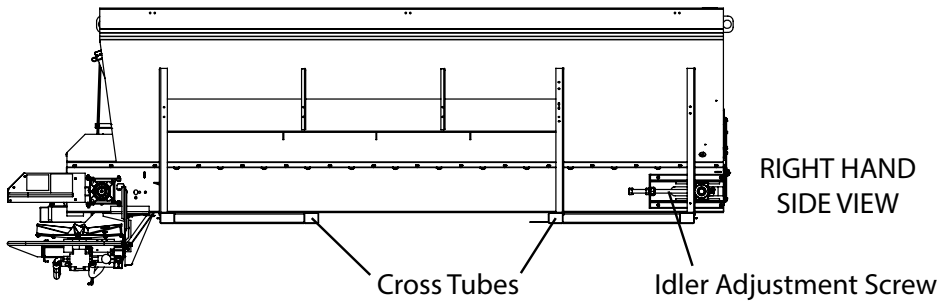
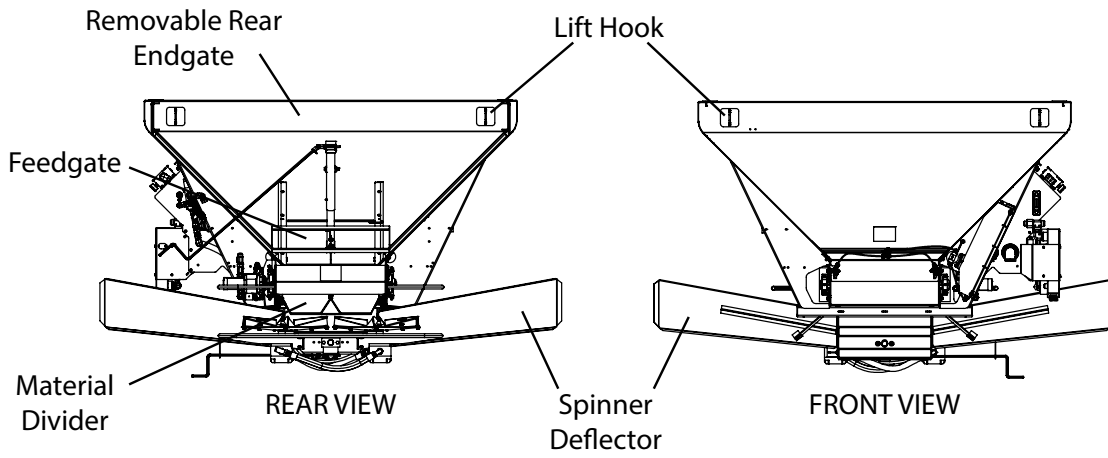
- Inserting the MULTAPPLIER allows for two materials to be spread simultaneously. It features a 24-inch (60.96 cm) belt-over-chain type conveyor having parallel strands of pintle type (#4) chain joined by cross bars every other link. The direct driven conveyor is also controlled independently enabling the delivery of material at variable rates through the adjustable gate at the rear of the hopper body. The hillside divider improves material placement on the spinner for a more effective spread pattern.
- Inserting the MULTIBIN will convert the spreader to a 3 or 4 hopper unit, which can be used independently or together for straight and variable rate applications. The front two hoppers dispense fertilizer products while the single or dual hopper at the rear dispense(s) micronutrients or seeding products. The rear bin(s) are sloped forward to improve chassis weight distribution. Material is delivered from the front bin by conveyor and from the rear bin(s) by passing through a meter wheel, material dividers and main spinner assembly with 24-inch (60.96 cm) diameter dished discs. Bin sensors are installed to warn when materials are low in each micronutrient bin.

The MULTIBIN also comes equipped with an upper and lower material divider which improves material placement on the spinner for a more effective spread pattern.

An optional micronutrient stainless steel cover which opens and closes with a stainless steel air cylinder is available.

Screens installed on micronutrient bins keep large chunks of material out of the bins by breaking the material up as it enters the bins.

This product is intended for commercial use only.



INTRODUCTION



Stake: Side support for main hopper walls.

Rear Endgate: Welded or bolt-in endgate (depending on model) furthest from chassis cab (Rear based on direction of travel). Holds mounted Feedgate, allowing for rear release of material from bin.

Bin 1: Main holding bin for material or Insert. Multiplier and MultiBin inserts (shown on following pages) are configured as Bins 2-4 depending on type used.

Feedgate: Adjustable gate mounted into Rear Endgate. Allows for variable rates of material flow by adjusting jack to desired height.

Conveyor: Conveys material to rear of unit.

Inverted "V": Mounted inside Main Hopper when Insert not installed. Distributes weight pressure across conveyor, allowing for consistent material flow to Feedgate, and promotes an improved blend when spreading fertilizer.

Material Divider: Ensures uniform spread pattern by directing material off of conveyor onto spinner discs.

Hillside Flow Divider: Ensures balanced flow of material across conveyor when on hillsides or uneven terrain.

Sill: Base of Main Hopper side walls. Contains Conveyor and supports machine walls.

Cross Tubes: Supports body, attaches to Chassis frame. Transfers weight from Main Hopper to Chassis.

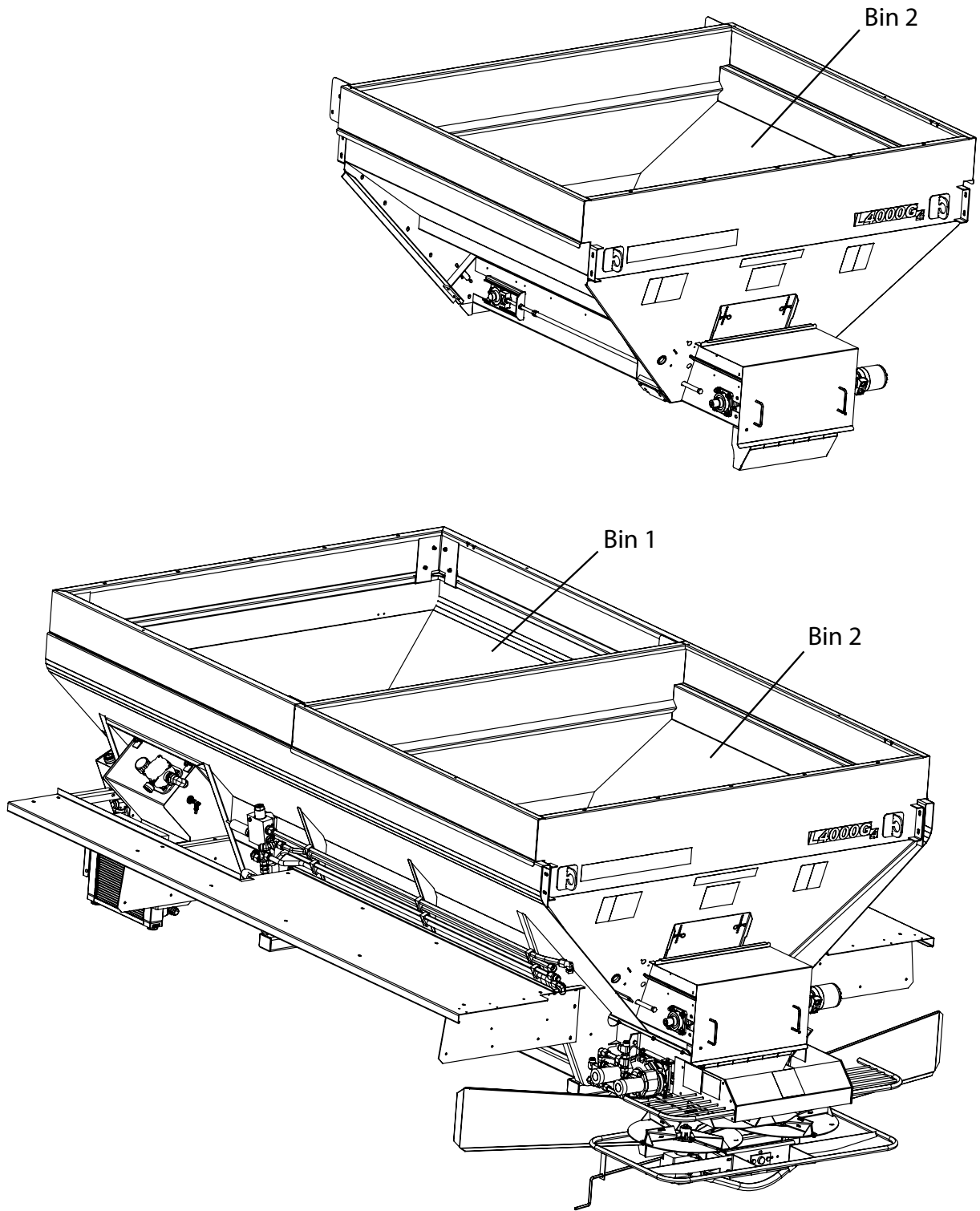
Spinner Assembly: Contains adjustable G4 Spreader system, consisting of hydraulic spinners used for dispersal of various materials at different positioned settings allowing for consistent, even spread patterns across a wide variety of materials with a high rate of accuracy.

Spinner Guards: Upper and Lower guards, protects operators from spinner discs. Must be in place during any operation.

Spinner Deflectors: Deflect material away from machine.

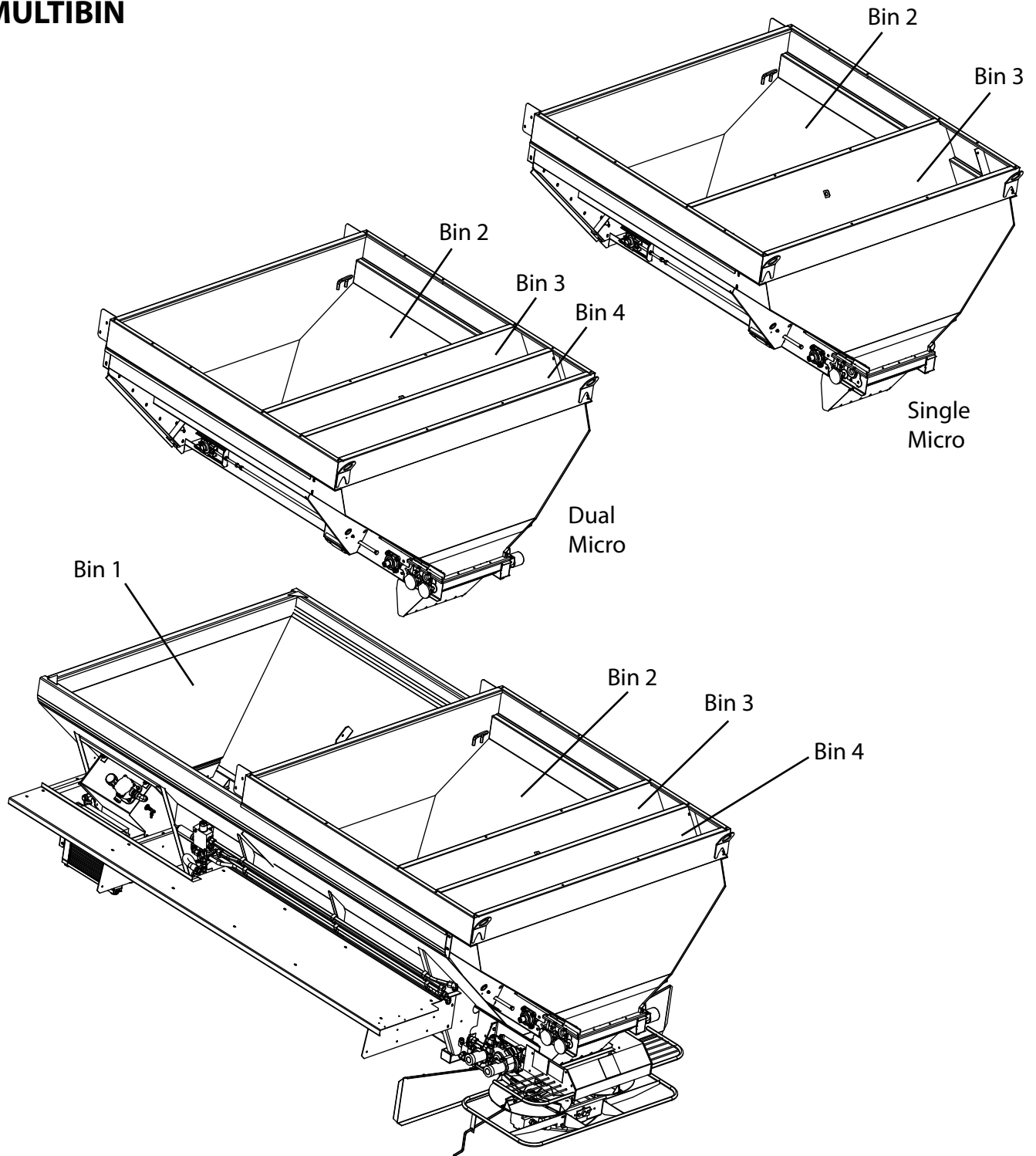
Lift Hooks: Used to lift unit or insert with appropriately rated lifting device.

MULTAPPLIER

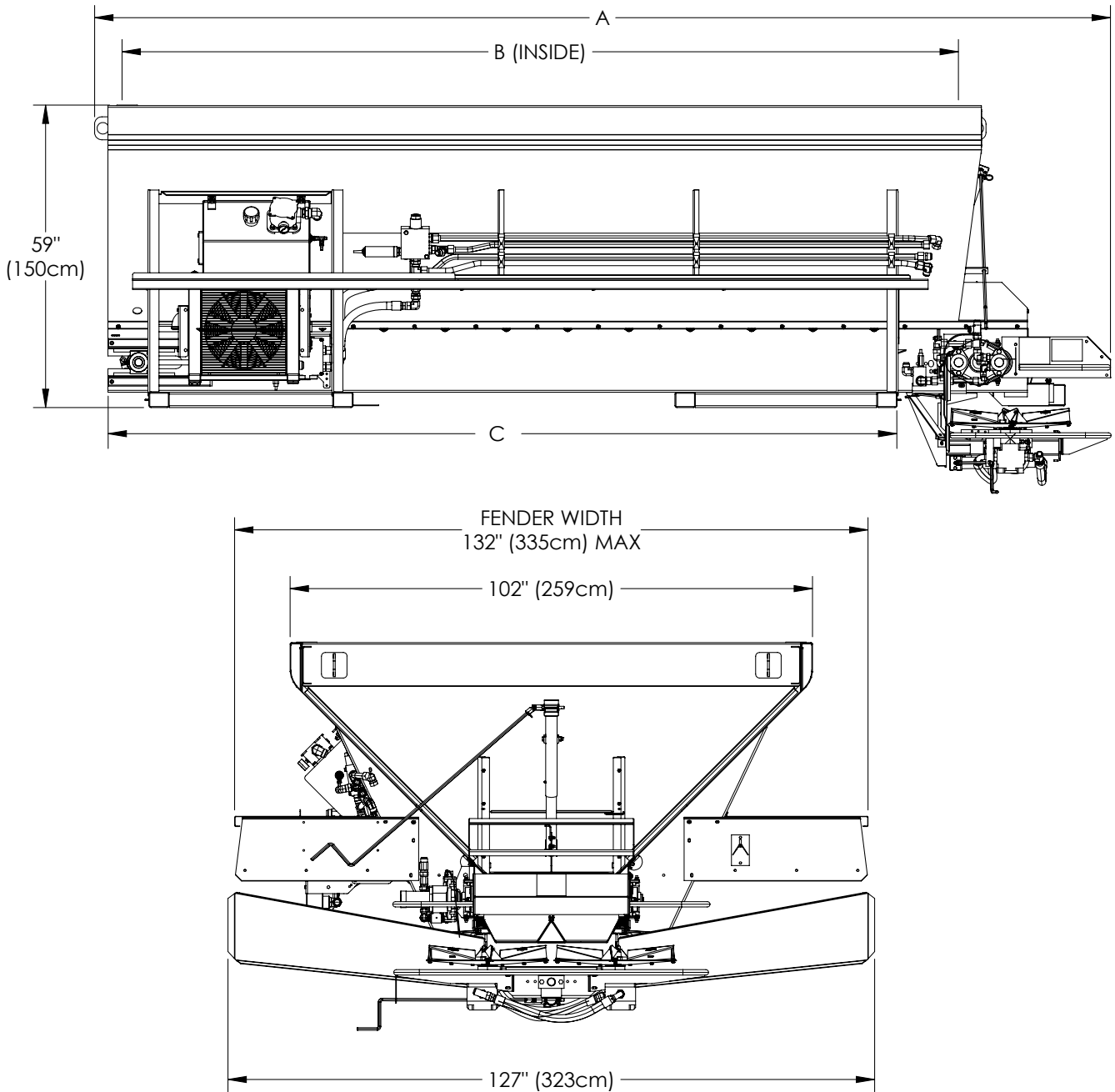


INTRODUCTION

MULTIBIN



L4000G4, SINGLE BIN



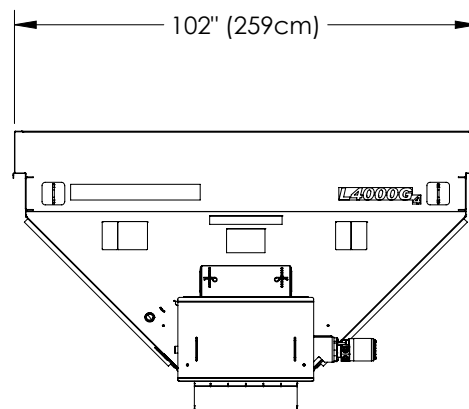
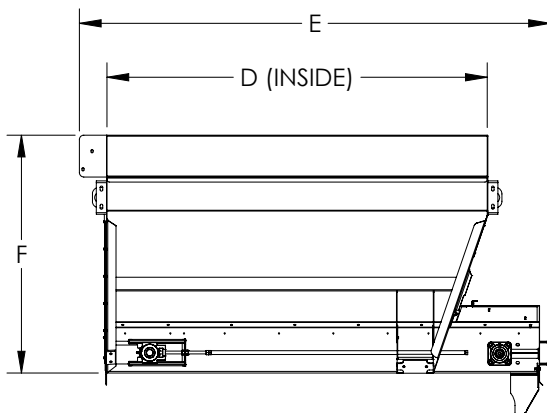
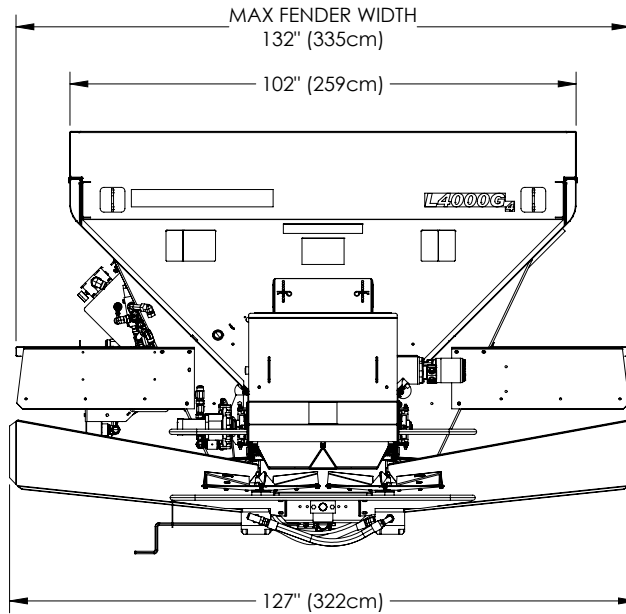
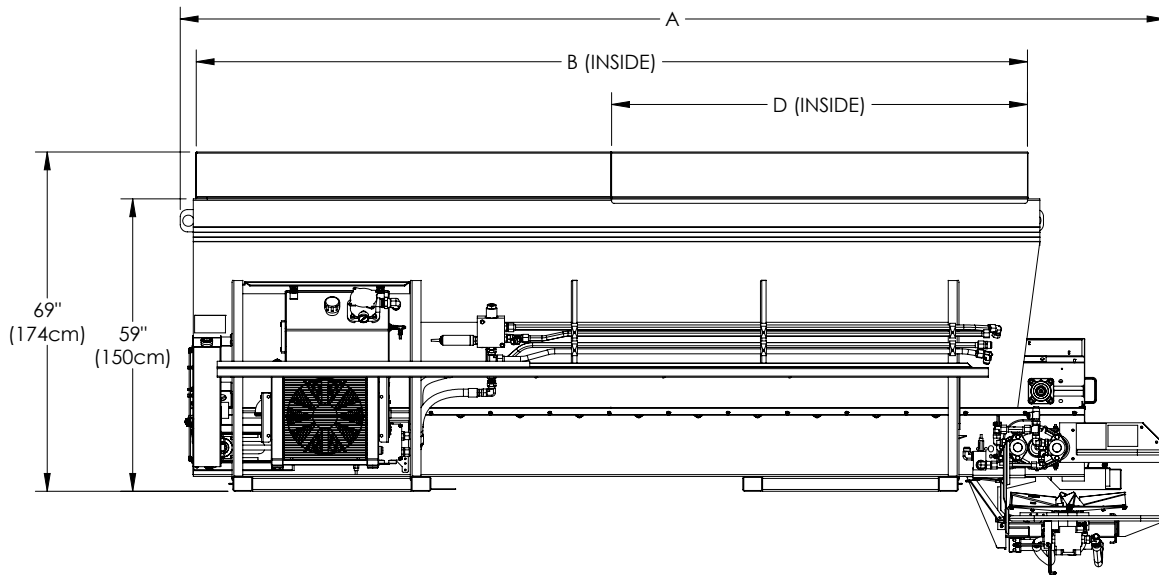
IMPORTANT! Please consult federal, state, and local weight laws and chassis manufacturer's ratings to ensure neither government weight restrictions nor GVWR and GAWR's are exceeded. Tire and tandem axle size may require mounting modification of optional mud flaps.

DIMENSIONS & CAPACITIES

L4000G4, SINGLE BIN WEIGHTS & CAPACITIES

Unit Length	Overall Length A	Inside Length B	Frame Length C	Approximate Weight Lbs (Kg)	Struck Capacity Cu Yd (Cu M) Cu Ft
14' (4.27m)	199" (505cm)	168" (427cm)	155" (394cm)	3930 (1783)	10.93 (8.35) 295

L4000G4 WITH MULTAPPLIER



DIMENSIONS & CAPACITIES

L4000G4 WITH MULTAPPLIER WEIGHTS & CAPACITIES

	With 5' MultApplier	With 5' MultApplier	With 7' MultApplier	With 7' MultApplier
Unit Length	Approximate Weight Lbs (Kg)	Struck Capacity Cu Yd (Cu M) Cu Ft	Approximate Weight Lbs (Kg)	Struck Capacity Cu Yd (Cu M) Cu Ft
14' (4.27m)	4610 (2091)	7.19 (5.50) 194	4825 (2189)	5.52 (4.22) 149

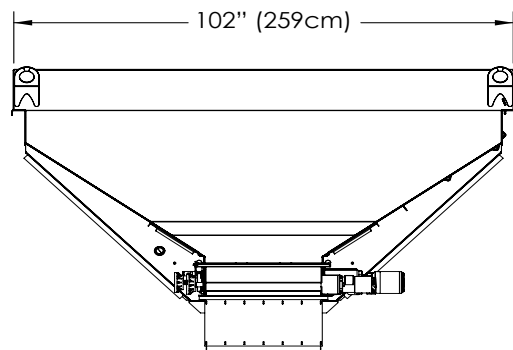
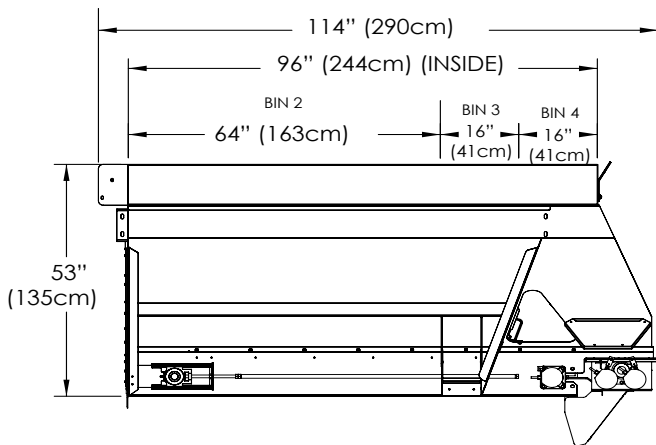
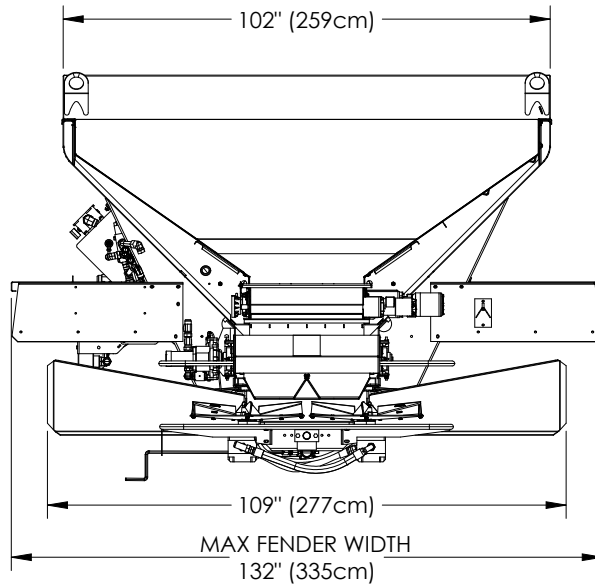
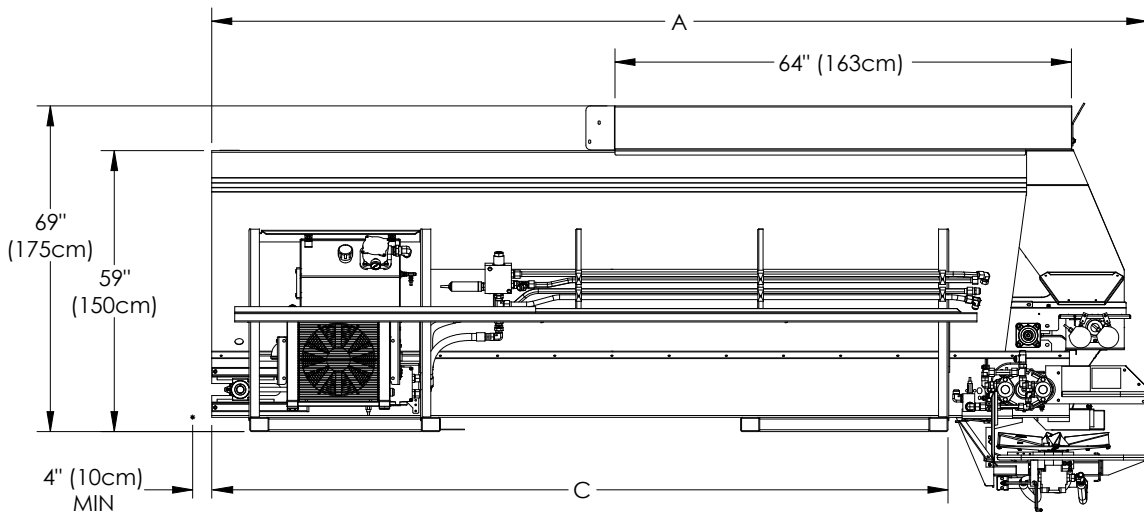
STYLE I MULTAPPLIER ALONE DIMENSIONS & CAPACITIES

Insert Unit Length	Inside Length D	Overall Length E	Height F	Approximate Weight Lbs (Kg)	Struck Capacity Cu Yd (Cu M) Cu Ft
5' (1.52m)	60" (152cm)	78" (198cm)	54" (137cm)	1000 (454.5)	4.26 (3.25) 115
7' (2.13m)	84" (213cm)	102" (259cm)	54" (137cm)	1200 (545.5)	5.96 (4.60) 161

STYLE II MULTAPPLIER ALONE DIMENSIONS & CAPACITIES

Insert Unit Length	Inside Length D	Overall Length E	Height F	Approximate Weight Lbs (Kg)	Struck Capacity Cu Yd (Cu M) Cu Ft
5' (1.52m)	60" (152cm)	80" (203cm)	53" (135cm)	1088 (493.5)	4.26 (3.25) 115
7' (2.13m)	84" (213cm)	104" (264cm)	53" (135cm)	1303 (591.0)	5.96 (4.60) 161

L4000G4 WITH MULTIBIN



DIMENSIONS & CAPACITIES

L4000G4 WITH MULTIBIN DIMENSIONS & CAPACITIES

Unit Length	Approximate Weight Lbs (Kg)	Struck Capacity Cu Yd (Cu M) Cu Ft
14' (4.27m)	5221 (2368)	5.52 (4.22) 149

MULTIBIN ALONE DIMENSIONS & CAPACITIES

	Inside Length	Approximate Weight Lbs (Kg)	Struck Capacity Cu Yd (Cu M) Cu Ft
MultiBin	96" (244cm)	1695 (768.8)	
MultiBin (Bin 2)	64" (162.2cm)		5.30 (4.05) 143
Single Micro (Bin 3)	32" (82cm)		1.63 (1.24) 44
Dual Micro (Bin 3)	16" (41cm)		.78 (.59) 21
Dual Micro (Bin 4)	16" (41cm)		.78 (.59) 21



WARNING Stand clear of moving machinery.

NOTE: Do not load spreader with material.

1. Check entire unit to make sure all fasteners are in place and properly tightened per “Standard Torques” in this manual.
2. Make sure no other persons are in vicinity of spreader.
3. Make sure no loose parts are in unit or on conveyor or spinner.
4. Check oil level in hydraulic reservoir; fill as necessary. Refer to “Lubricant & Hydraulic Oil Specifications” in this manual for proper oil. Completely open reservoir valves.
5. Start engine and turn on hydraulics. Allow hydraulics to circulate until oil is warm.
6. Run spinner only at 300RPM. Allow to run until spinner is operating smoothly and all air has been purged from system.
7. Run conveyor at 20RPM and spinner at 300RPM. Run until conveyor is operating smoothly.
8. Run conveyor at 20RPM and spinner at 700RPM. Allow both conveyor and spinner to run until operating smoothly.
9. Run conveyor at 0RPM and spinner at 0RPM. Make sure both conveyor and spinner do not move.
10. Calibrate spreader as defined in the manual for the controller that is supplied with your machine.
11. Complete spread pattern test per “Spread Pattern Testing Procedures” in this manual.
12. Shut system down.



WARNING

DO NOT check leaks with hands while system is operating as high pressure oil leaks can be dangerous! If skin is pierced with hydraulic fluid at high pressure seek immediate medical attention as fluid injected into the skin could cause gangrene if left untreated. Relieve pressure before disconnecting hydraulic lines or working system. Make sure all hydraulic fluid connections are tight and all hydraulic hoses and lines are in good condition before applying pressure to the system. Wear protective gloves and safety glasses or goggles when working with hydraulic systems.



WARNING

DO NOT check for leaks adjacent to moving parts while system is operating as there may be danger of entanglement!

13. Check all connections in hydraulic system to make sure there are no leaks.
14. Check hydraulic oil reservoir and refill to maintain level at mid-point of gauge.

G4 SPINNER SQUARINGClick or Scan -
Single Bin UnitClick or Scan -
MultiBin Unit

The squareness of the G4 Spinner Assembly and supporting parts plays a critical role in obtaining acceptable spread patterns. It is highly recommended that measurements are checked before spreading with a new unit, and any time after service or repair work has been performed on any part affecting spread patterns.

1. Figure 1 - Begin by ensuring that the Spinner Assembly is mounted correctly. The Spinner Frame should be sitting on top of/inside the Sill flanges, NOT hanging below.

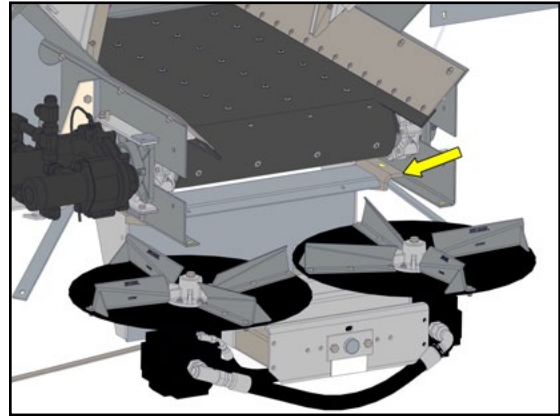


Figure 1

2. Figure 2 - Measure from the Spinner Frame mounting flange to the end of the Sill on each side. Measurement should be 9-7/8" (25cm). Measurements must be equal, or no greater than 1/8" (0.3cm) off overall.

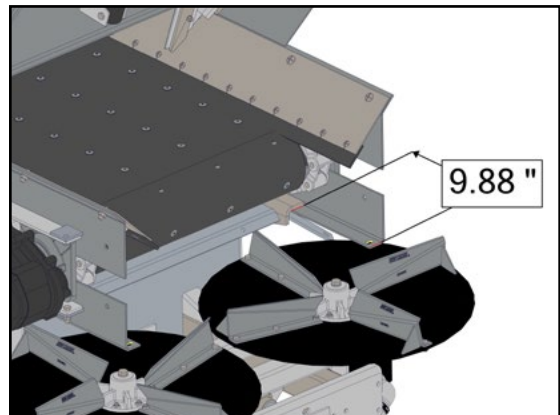


Figure 2

3. Figure 3A - 3B - Check Spinner Assembly squareness by measuring from top edge of left hand Sill to inner hex flat on right hand Spinner Hub bolt. Repeat for opposite side.

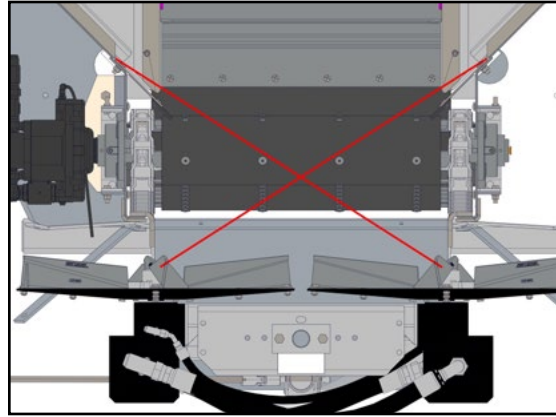


Figure 3A

4. Measurements must be equal, or no greater than 1/8" off overall.

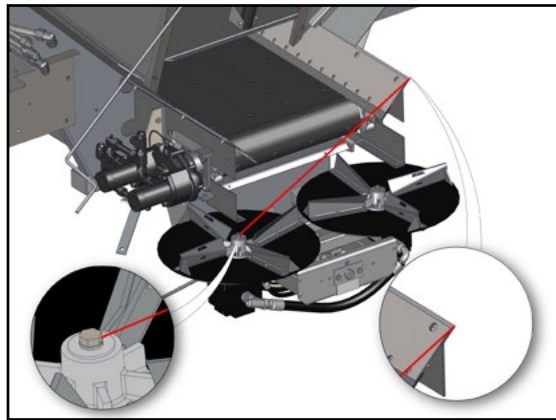


Figure 3B

5. Figure 4 - If adjustments are necessary, loosen the four 1/2" carriage bolts and adjust assembly as necessary. Once corrected, tighten hardware to recommended torque. See "Standard Torques" for details.

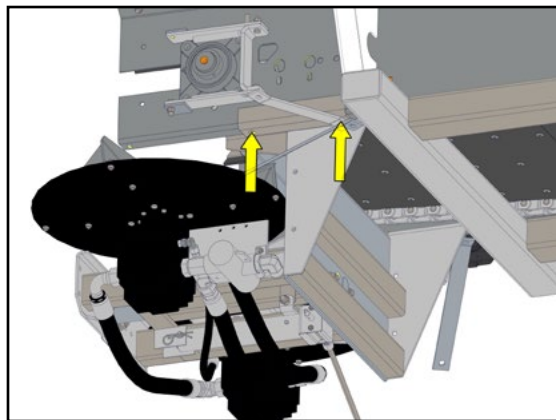


Figure 4

6. Figure 5 - Center Material Divider by measuring from the right hand inner drop-off point to the inner hex flat on the right hand Spinner Hub Bolt. Repeat measurement on opposite side. Measurements must be equal, or no greater than 1/8" off overall.

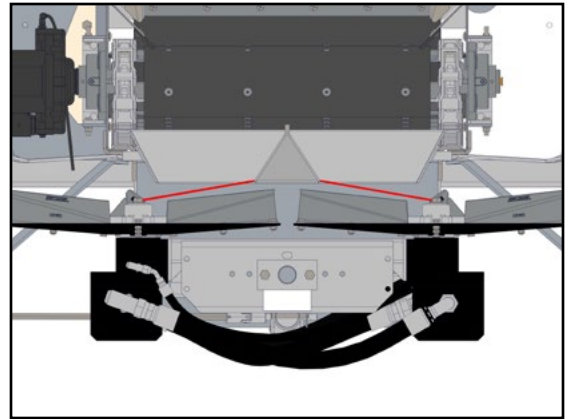


Figure 5

7. Figure 6 - Measure on each side from Spinner Frame back plate to forward drop-off point on Material Divider. Both measurements must be 12-1/4" (31cm) or no greater than 1/8" (0.3cm) off overall.
8. Figure 7 - If adjustments are necessary, loosen the 3/8" capscrews on each side and adjust as necessary. Once corrected, tighten hardware to recommended torque.

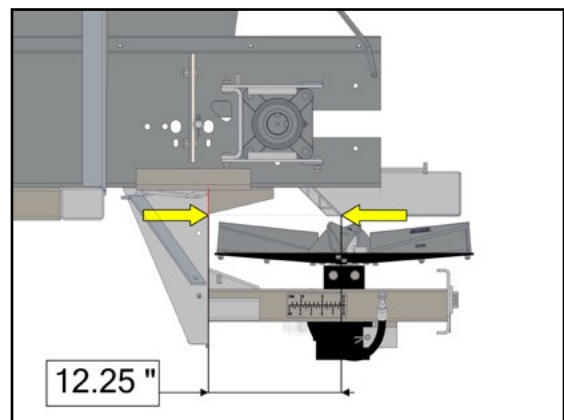


Figure 6

9. Figure 8 - If equipped, Ensure the Hillside Divider is mounted squarely and centered at both the front and the rear. Hillside Divider panel should be perpendicular to ground. Ensure the rear of the panel is centered over the center section of the Material Divider.

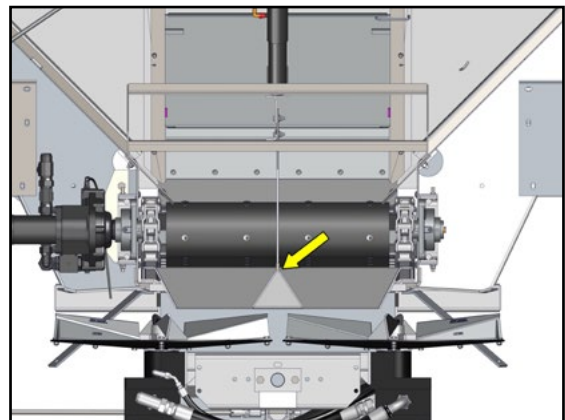


Figure 8

10. Figure 9 - Center the front of the Hillside Divider by measuring from the divider panel to the Chain Shield rubber on each side. Measurements should be equal.

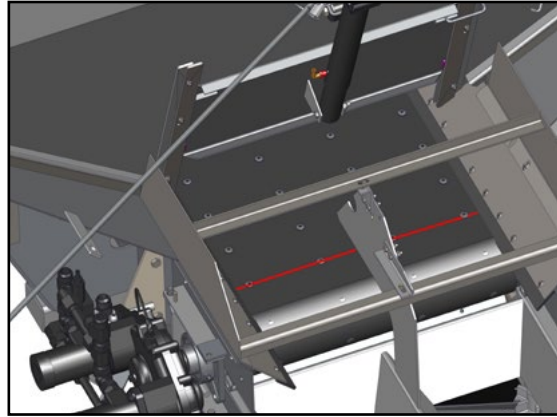


Figure 9

11. Figure 10 - Lastly, ensure that the Hillside Divider panel has proper clearance from the belt. The bottom edge of the divider panel should be approximately 3/8" (1cm) from the rubber belting of a #4 BOC.
12. If adjustments are necessary, loosen the hardware at the Hillside Divider panel as required and adjust as necessary. Once corrected, tighten hardware to proper torque.

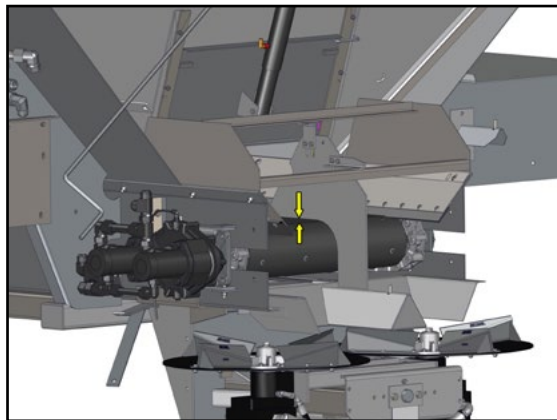


Figure 10

13. Figure 11 - Ensure all guards and shields are securely in place.

The spreader is now ready for field testing.

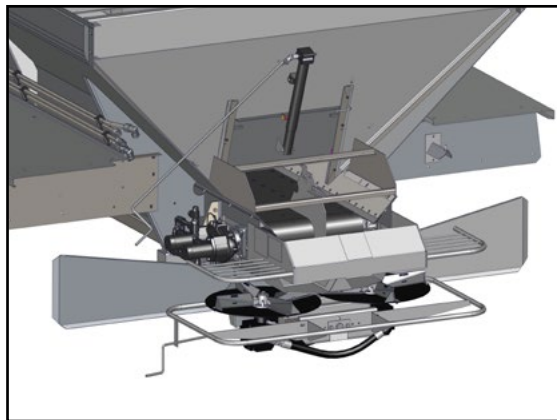


Figure 11

FIELD TESTING

The following procedure is a guide:

NOTE: Do NOT fill spreader with material

1. Field test over any suitable course which allows vehicle to be driven at speeds to be used while spreading.
2. Ensure unit has been properly serviced, that the hydraulic reservoir is full and gate valve under reservoir is fully open. Do not load spreader.
3. Run spinners at 500 RPM.

**DANGER**

Take proper safety precautions when observing conveyor and spinner speed while vehicle is in motion! These may include use of suitable mirrors clamped to permit observation by a safely seated observer, following the spreader in another vehicle at a safe distance, or other suitable means. Do not stand on fenders, in body or on any part of spreader as there is danger of falling off the vehicle or into moving parts! Use great care in performing this test!

4. Start engine. Turn control to "on" position. Engage PTO and allow to run at fast idle long enough to bring hydraulic oil up to operating temperature. Spinners should revolve at moderate speed and the conveyor should not move.
5. Refer to controller's operation manual for conveyor operating instructions. Set program to operational mode and begin forward travel. Move conveyor switch to "on" position. Conveyor should start immediately when vehicle moves and should continue to run at speeds which should vary directly with the vehicle's ground speed; the conveyor should speed up as vehicle speed increases and slow down as vehicle speed reduces. Spinner speed should remain constant when engine speed is above minimum operating range.

GENERAL OPERATING PROCEDURES

1. Make sure unit has been properly serviced and is in good operating condition. It is highly recommended to run the spreader prior to loading material to ensure acceptable operation.
2. Program controller with correct data for material(s) and application.
3. Adjust feedgate to appropriate setting.
4. Adjust spinner to give spread pattern desired. Calibrate and spread pattern test for any new material.
5. Fill applicable bins with material to be spread.
6. Engage hydraulics.
7. Begin spreading.

**CAUTION**

Drive only at speeds which permit secure control of vehicle.

NOTICE!

CHANGE HYDRAULIC OIL FILTER AFTER FIRST WEEK (OR NOT MORE THAN 50 HOURS) OF OPERATION ON A UNIT.

*Visit www.newleadervip.com for interactive tools to calculate yield, proper feedgate opening, conveyor revolutions per minute and mph to maximize the performance of your spreader.

This page is intentionally left blank.

PREVENTATIVE MAINTENANCE PAYS!

The handling and spreading of commercial fertilizers is a most severe operation with respect to metal corrosion. Establish a frequent, periodic preventative maintenance program to prevent rapid deterioration to spreading equipment. Proper cleaning, lubrication and maintenance will yield longer life, more satisfactory service and more economical use of your equipment.



WARNING Shut off all power and allow all moving parts to come to rest before performing any maintenance operation.

HYDRAULIC SYSTEM

Proper oil in the hydraulic system is one of the most important factors for satisfactory operation. Utmost cleanliness in handling the oil cannot be stressed enough. Keep hydraulic oil in original closed containers, clean top of container before opening and pouring, and handle in extremely clean measures and funnels.

Refer to “Lubricant and Hydraulic Oil Specifications” for selection of the proper hydraulic fluid for use in the hydraulic system.

SERVICE SCHEDULE

WARNING DO NOT check leaks with hands while system is operating as high pressure oil leaks can be dangerous! If skin is pierced with hydraulic fluid at high pressure seek immediate medical attention as fluid injected into the skin could cause gangrene if left untreated. Relieve pressure before disconnecting hydraulic lines or working system. Make sure all hydraulic fluid connections are tight and all hydraulic hoses and lines are in good condition before applying pressure to the system. Wear protective gloves and safety glasses or goggles when working with hydraulic systems.



WARNING DO NOT check for leaks adjacent to moving parts while system is operating as there may be danger of entanglement!

Check hydraulic oil daily by means of sight gauge on reservoir. Add oil as necessary to maintain level around mid-point of sight gauge. Periodically inspect hoses and fittings for leaks.

NOTICE! Change hydraulic oil filter after first week (or not more than 50 hours) of operation on a unit.

After first filter change, replace filter when indicator reaches Red Zone.

Drain reservoir through drain plug (not through suction outlet), flush, and refill and change filter element annually. Oil and filter should also be changed whenever oil shows any signs of breaking down under continued high-pressure operation. Discoloration of oil is one sign of breakdown.

CONVEYOR GEARCASE

Drain oil in a new unit after first two weeks (or not more than 100 hours) of operation, and flush gear case thoroughly with light oil. Refer to "Lubricant and Hydraulic Oil Specifications" section for proper grade oil and recommended amounts of lubricant. After initial change, oil should be changed every 2,000 hours of operation or annually, whichever occurs first.

Check gearcase oil level monthly.

HYDRAULIC HOSE

Hose assemblies in operation should be inspected frequently for leakage, kinking, abrasion, corrosion or other signs of wear or damage. Worn or damaged hose assemblies should be replaced immediately.



WARNING

Testing should be conducted in approved test stands with adequate guards to protect the operator.



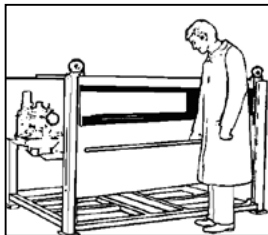
Clean

Clean assembly by blowing out with clean compressed air. Assemblies may be rinsed out with mineral spirits if the tube stock is compatible with oil, otherwise hot water at 150°F (65.55° C) maximum may be used.



Inspect

Examine hose assembly internally for cut or bulged tube, obstructions, and cleanliness. For segment style fittings, be sure that the hose butts up against the nipple shoulder; band and retaining ring are properly set and tight, and segments are properly spaced. Check for proper gap between nut and socket or hex and socket. Nuts should swivel freely. Check the layline of the hose to be sure the assembly is not twisted. Cap the ends of the hose with plastic covers to keep clean.



Test

The hose assembly should be hydrostatically tested at twice the recommended working pressure of the hose.

Test pressure should be held for not more than one minute and not less than 30 seconds. When test pressure is reached, visually inspect hose assembly for: 1. Any leaks or signs of weakness. 2. Any movement of the hose fitting in relation to the hose. Any of these defects are cause for rejection.

Storage and Handling

Hose should be stored in a dark, dry atmosphere away from electrical equipment, and the temperature should not exceed 90° F (32.22° C).

CONVEYOR CHAIN**WARNING**

Stay out of the hopper body. If it's necessary to enter the hopper, return to the shop, empty body, turn off all power, set vehicle brakes, lock engine starting switch and remove keys before entering. Tag all controls to prohibit operation. Tags should be placed, and later removed, only by person working in the body.

Hose down unit and remove any material build-up on sprockets and under chain.

NOTICE!

The conveyor will move away from the bottom panel if material accumulates under the conveyor or on the sprockets. The more material that accumulates, the closer the chain will come to the chain shields. If the conveyor should catch a chain shield, it could permanently damage the conveyor, the chain shields or the unit. Do not remove material while conveyor or spinner is running!

LUBRICATION

Make sure unit is clean and completely dry. Lubricate conveyor chain at the end of each day of usage using a mixture of 75% diesel fuel and 25% SAE 10 oil. Shut down spinner and run conveyor at 20 RPM for two full revolutions to lubricate chain. After each unit washing, allow to dry, then lubricate.

Lubricate MULTAPPLIER/MULTIBIN conveyor chain bi-weekly and at end of each season with Fluid Film™ or equivalent. Shut down spinner and run conveyor at 20 RPM. Lubricate chain through two full revolutions. After each unit washing, allow to dry, then lubricate.

Before filling the unit with spreading material, activate the controller or power switch to run the pump oiler. Bleed all air from the lines and adjust the two spray nozzles so that the oil mixture sprays vertical onto the sprockets and chain.

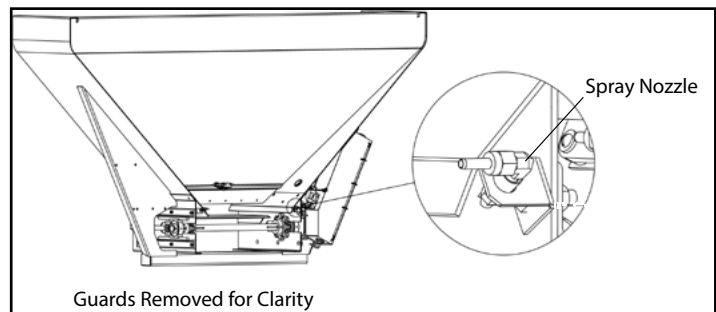


Figure 1 - Spray Nozzle

TENSION

Proper chain tension is also a factor in chain and sprocket life. Measure from rear of main unit forward to achieve proper chain tension (Figure 2). Make sure chain is tensioned equally on both sides. This adjustment is made on each side of the unit at the front idler bearings.

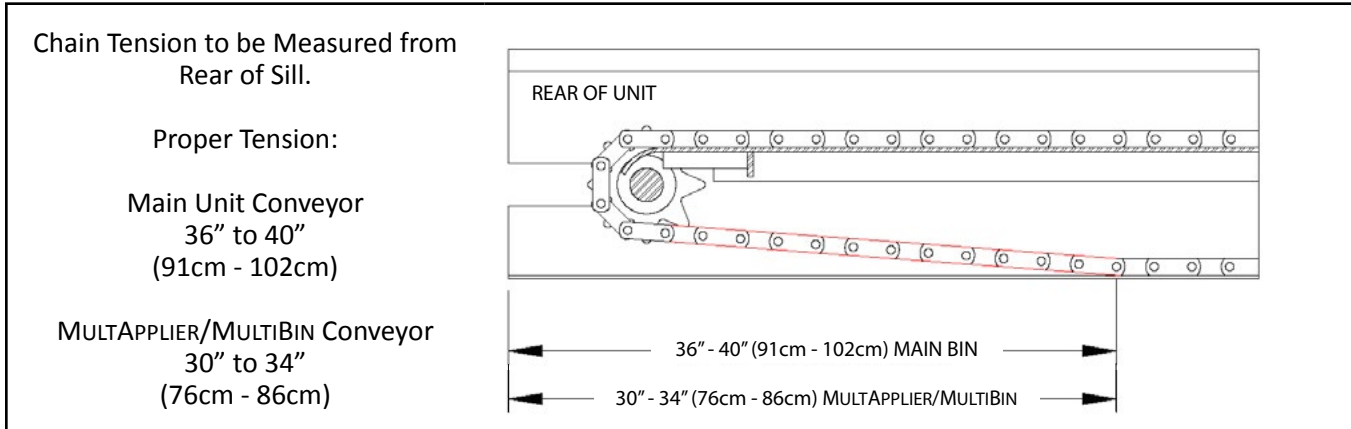


Figure 2 - Chain Tension, Main Unit

Conveyor chains that are too tight will tend to stretch, causing excess sprocket wear and eventually breakage. Excess slack presents the possibility of chain catching on sub-frame parts. Bent or distorted chain bars will cause damage to unit as well as fertilizer leakage with #3 conveyors. Straighten or replace bent or distorted chain bars immediately.

#4 BOC CONVEYOR BELT MAINTENANCE

Standard belting for the #4 conveyor is moderately oil resistant (MOR) that is impervious to moisture, weathering, and normal action which can be used with chemical-impregnated fertilizer or oil-based additives.

- Inspect belt fastener occasionally for wear or "raveling" of belt grip area.
- Make sure belt connecting pin is positioned correctly as shown in Figure 3.

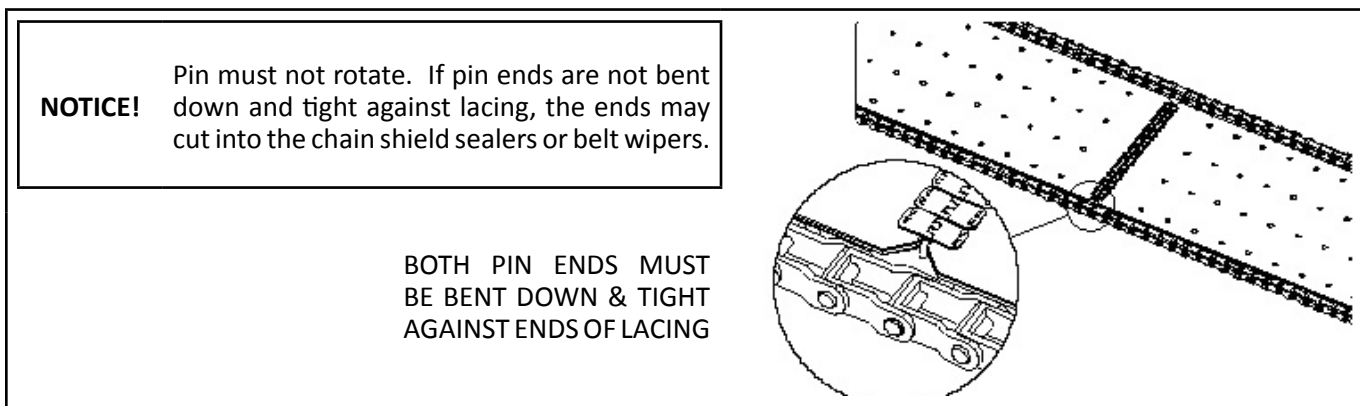


Figure 3 - Conveyor Belt Connecting Pin Installation

LUBRICATION & MAINTENANCE

BIN SENSOR**WARNING**

Stay out of the spreader. Do not climb on spreader. Use a portable ladder to inspect, clean and maintain the bin sensor from outside the spreader. Failure to do so could result in injury from falling.

NOTICE!

Wipe sensor clean periodically to prevent accumulation of product. Avoid wet material as it may stick to sensor. If material sticks to sensor it won't warn user when bin is low.

Clean sensor with long handled brush or hose from outside of spreader. Do not aim high pressure sprayer directly at sensor—it could damage the components.

LUBRICATION OF BEARINGS

Grease in a bearing acts to prevent excessive wear of parts, protects ball races, and balls from corrosion and aids in preventing excessive heat within the bearing. It is very important the grease maintain its proper consistency during operation. It must not be fluid and it must not channel.

Make sure all fittings are thoroughly cleaned before grease is injected. Points to be lubricated by means of a grease gun have standard grease fittings.

Lubricate bearings by pumping grease slowly until it forms a slight bead around the seals. This bead indicates adequate lubrication and also provides additional protection against the entrance of dirt.

FASTENERS

Tighten all screws fasteners to recommended torques after first week of operation and annually thereafter. If loose fasteners are found at anytime, tighten to recommended torque. Replace any lost or damaged fasteners or other parts immediately. Check body mounting hardware every week.

CLEAN-UP**NOTICE!**

High pressure wash can inject water and/or fertilizer into control components, causing damage. Use caution when cleaning these areas.

Thoroughly wash unit every two to three days during the operating season to maintain minimal maintenance operation. Hose unit down under pressure to free all sticky and frozen material.

It is important the unit be thoroughly cleaned at the end of each operating season. All lubrication and maintenance instructions should be closely followed. Repaint worn spots to prevent formation of rust.

MULTIBIN Meter Wheel(s): Pull inspection plug on right hand side of micro assembly. Blow out with compressed air.

Spinner Fins

Visually inspect spinner fins (Figure 4) daily for build-up of material and wear. Spinner discs and fins must be kept clean and polished. Even a small build-up of material on a spinner can significantly affect the spread pattern. Rough, bent or worn fins will produce poor spread patterns. Replace worn fins and discs as needed. See *Fin Kit Installation Instructions* for replacement part numbers and instructions.

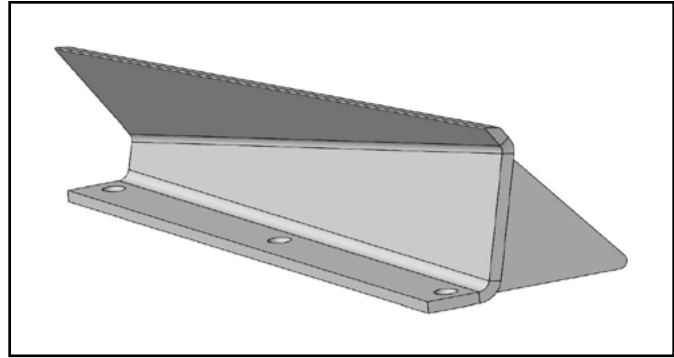


Figure 4 - Spinner Fin

Spinner Deflectors

Visually inspect spinner deflectors (Figure 5) daily for build-up of material and damage. Clean as needed. Even a small build-up of material on a spinner deflector can affect the spread pattern. If damaged, bent or otherwise, replace. See parts manual for replacement part numbers.

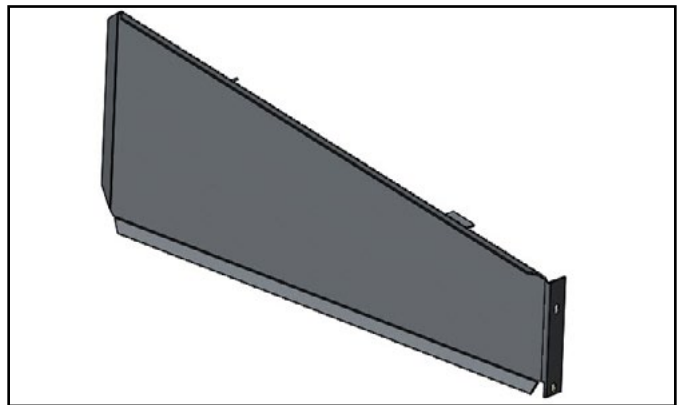


Figure 5 - Spinner Deflector

Material & Hillside Flow Dividers

Visually inspect material divider (Figure 6) and hillside flow dividers (as equipped) daily for build-up of material and wear. Any build-up of material on divider components can affect performance. Clean as needed. Replace worn or damaged parts as necessary. See parts manual for replacement part numbers.

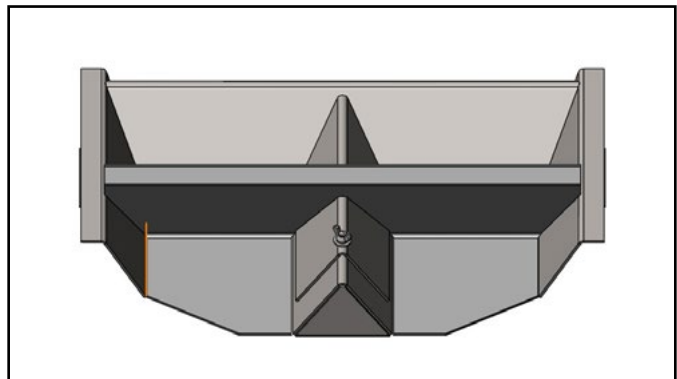


Figure 6 - Material Divider

HYDRAULIC SYSTEM

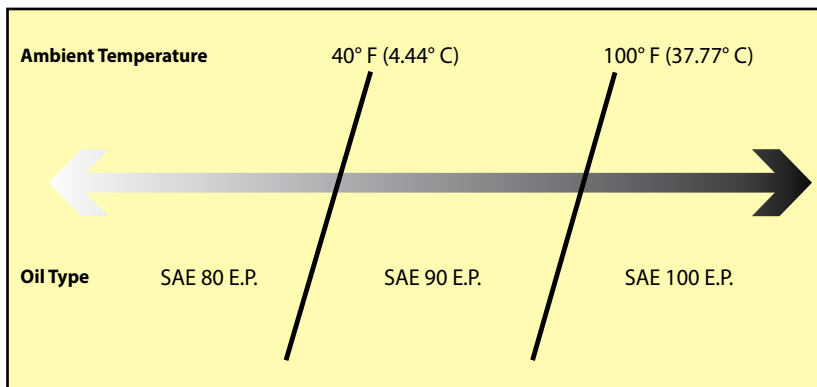
Use premium quality lubricants with 100-200 SUS or 20-43 cSt viscosity at operating temperatures. The hydraulic fluid's specifications in the table below are for normal operating conditions. Extreme environments or dirty conditions may require the use of different oils. Consult your New Leader dealer or the Product Support Department at Highway Equipment Company for systems operating outside normal conditions.

Ideal Oil Operating Temperature	115-158°F (46.11-70° C)
Recommended Premium Lubricant	Multi-Purpose Agriculture Hydraulic & Transmission Oil
Lubricant Specifications	
Viscosity Index	Greater than 130
Viscosity at 40°C, cst	Less than 68
Viscosity at 100°C, cst	Greater than 9
Acceptable Fluid Example	Mobil 424

GEARCASE LUBRICANT

Lubricate these assemblies with non-corrosive type extreme pressure (E.P.) gear oil conforming to MIL-L2105 B multi-purpose gear lubricating oil requirements (API Service GL 4) based on ambient temperatures listed below. Refill gear case with one and a half (1-1/2) pints (.70 liters) of recommended lubricant.

Ambient Temperature	Below 40° (4.44°C)	Between 40° (4.44°C) and 100° (37.77°C)	Above 100° (37.77°C)
Oil Type	SAE 80 E.P.	SAE 90 E.P.	SAE 140 E.P.



GREASE GUN LUBRICANT

Use a waterproof ball and roller bearing lithium base lubricant with a minimum melting point of 300°F (148.8° C). This lubricant should have a viscosity which assures easy handling in the pressure gun at prevailing atmospheric temperatures. The grease should conform to NLGI No. 2 consistency.

CHAIN CONVEYORS

Use a mixture of 75% No. 1 or No. 2 diesel fuel or kerosene mixed with 25% SAE 10 engine oil in the main unit conveyor chain oiler.

Spray MULTAPPLIER/MULTIBIN conveyor chain with Fluid Film™ spray lubricant or equivalent.

**WARNING**

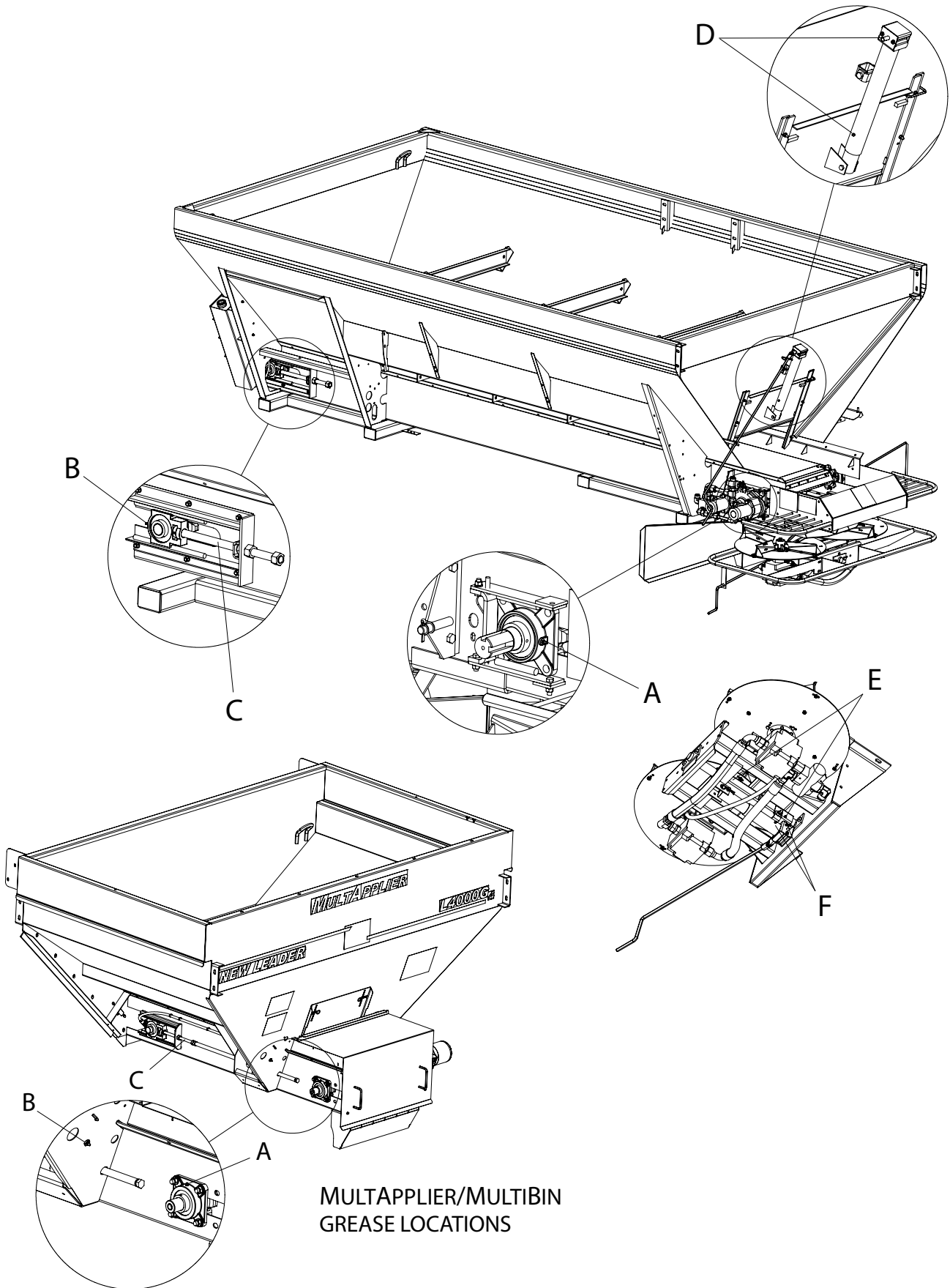
Shut off all power and allow all moving parts to come to rest before performing any maintenance operation.

The spreader should be regularly lubricated with the lubricants recommended in this manual in accordance with the following chart:

Location	Places	Method	Frequency
Transmission PTO			
Slip Yoke	1	Grease Gun	Weekly
Universal Joint	2	Grease Gun	Monthly
Hydraulic System			
Reservoir	1		Check Daily. Change Annually
Filter	1	Check daily; Change when indicated (Red)	
Conveyor			
Grease Zerks - Dragshaft Bearings (A)	2	Grease Gun	Weekly
Grease Zerks - Idler Shaft Bearings (B)	2	Grease Gun	Weekly
Take-Up Screws (C)	2	Hand Grease	Weekly
Grease Zerks - Snubber Pulley Bearings (D)	2	Grease Gun	Weekly
Gearcase	1	Gear Oil	Check Monthly; Change Annually
Feedgate Jack Assembly			
Grease Zerks (E)	1	Grease Gun	Annually
Spinner			
Grease Zerks - Shaft (F)	2	Grease Gun	Weekly
Grease Zerks - Jack (G)	2	Grease Gun	Weekly

NOTE: Unusual conditions, such as excessive dust, temperature extremes or excessive moisture may require more frequent lubrication of specific parts.

*See "Lubricant and Hydraulic Oil Specifications" for types of lubricants and oil to be used.

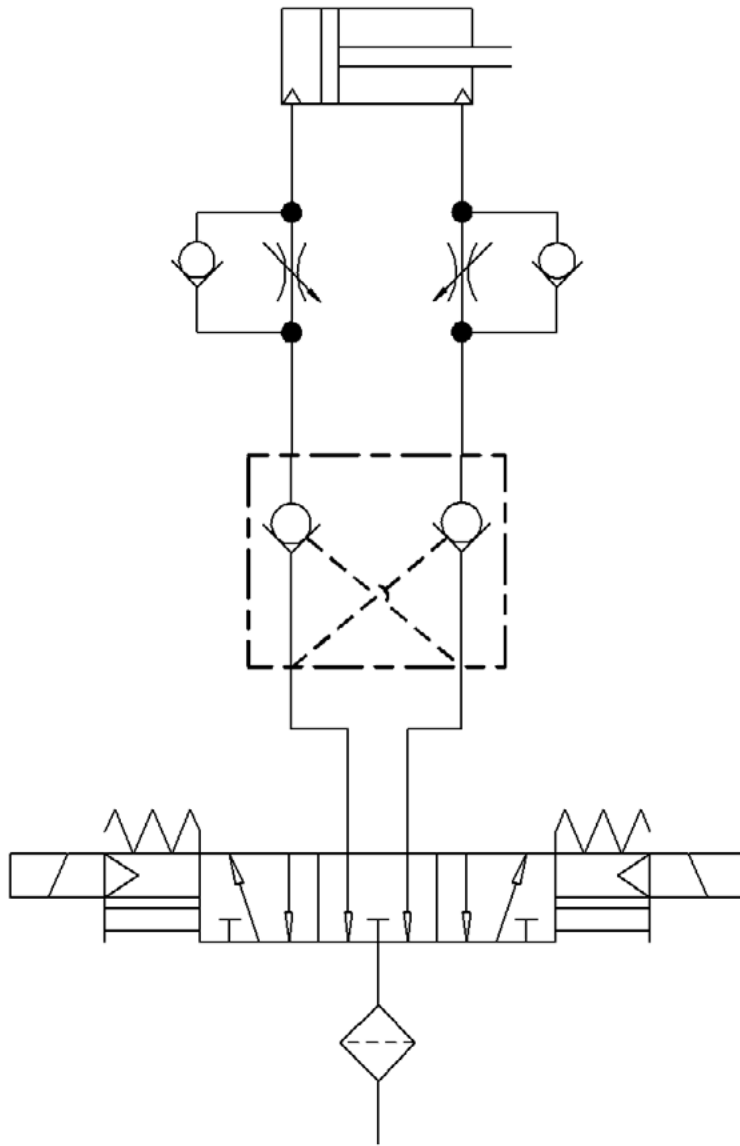


MULTIPLIER/MULTIBIN
GREASE LOCATIONS

Symptom:	Reason:	Correction:
Spinner will not run	Defective Spinner Control Valve	Replace spinner control valve cartridge and coil.
	No voltage at valve	Verify spinner switch is on.
		Verify spinner enable is checked.
		Verify controller has a target spinner RPM entered.
		Check WSM 7.5 amp fuse is not blown.
		Verify spinner control harness is not damaged.
	Verify system was configured as Basic independent.	
	No hydraulic flow	Verify hydraulics are on.
Pressure test pump - replace as needed.		
System is going over relief - test & replace as needed.		
Spinner will not shut off	Defective spinner control valve	Replace spinner control valve cartridge.
	Control valve is manually override	Loosen jam nut on control valve cartridge and back set screw out until spinner stops.
Spinner runs erratic	Defective spinner control valve	Replace spinner control valve cartridge.
	Spinner speed sensor harness failure	Replace sensor harness.
	Spinner speed sensor not properly installed	Adjust sensor so that gap between sensor and fin mounting bolt is less than 1/8".
Spinner speed drops off when turning around	Improper control settings	Verify PWM control is set properly (HOLD for gear pumps, CONTROL for variable displacement).
Spinner speed does not hit target	Defective spinner control valve	Replace spinner control valve cartridge.
	Pump failure	Flow and pressure test pump.
	Spinner speed sensor not properly installed	Adjust sensor so that gap between sensor and fin mounting bolt is less than 1/8".
	Hydraulic flow dropping off	Adjust settings and speed. Pressure test relief (adjust or replace as needed).
	Spinner speed sensor harness failure	Replace sensor harness.
	Spinner speed sensor failure	Replace spinner speed sensor.
Conveyor will not run	Defective conveyor control valve	Replace conveyor valve cartridge.
	No voltage at valve	Verify bin switch and master switches on.
		Verify in controller that target rate, density, ground speed and a CFR number are all entered.
		Check WSM 7.5 amp fuse is not blown.
		Verify conveyor control harness is not damaged.
	No hydraulic flow	Verify hydraulics are on.
		Pressure test pump - replace as needed.
		System is going over relief - test & replace as needed.
Conveyor is going over relief - test & replace as needed.		

Symptom:	Reason:	Correction:
Conveyor will not shut off	Defective conveyor cartridge	Replace conveyor control valve cartridge.
	Control valve is out of time	Adjust cartridge timing.
Conveyor runs erratic	Defective conveyor cartridge	Replace conveyor control valve cartridge.
	Encoder failure	Replace encoder.
	Encoder harness failure	Replace harness.
	Rates smooting is disabled	Enable rate smoothing.
Bin will not hit target rate	Defective conveyor cartridge	Replace conveyor control valve cartridge.
	Pump failure	Flow and pressure test pump.
	Going over relief	Adjust setting and speed. Pressure test relief (adjust or replace as needed).
	Encoder failure	Replace encoder.
	Encoder harness failure	Replace harness.
Hydraulics over-heating	Pump failure	Flow and pressure test pump.
	Too much flow	Flow test pump.
	System relief	Pressure test relief (adjust or replace as needed). Adjust settings and speed.
	Conveyor valve relief	Pressure test relief (adjust or replace as needed). Adjust settings and speed.
	Oil cooler fan failure	see oil cooler fan failures.
	Case drain is plugged.	Case drain requires zero pressure line back to tank.
Oil cooler fan failure	No power at fan	Verify FAN 30-amp fuse is not blown. Verify relay is working properly.
	Fan failure	Replace fan.
Bin level sensors not working properly	Not enabled	Verify system was configured with bin level snesors installed.
	Bin level sensor failure	Replace sensor.
	Bin level sensor harness failure	Replace harness.
Not applying correct rate	Incorrect settings	Verify density, swath width, gate opening, encoder pulses, and CFR number are all adjusted as needed.
No ground speed	Manual speed is enabled, but set to 0	Enter correct speed or disable manual speed
	AUX broadcast speed is enabled but radar not installed	Disable broadcast AUX speed.
	Incorrect speed source is selected	Select correct speed source.

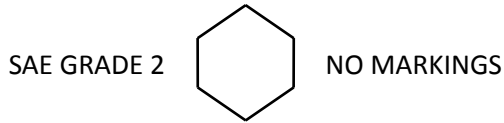
MULTIBIN COVER AIR SCHEMATIC



AUXILLARY SUPPLY LINE
DRY AIR
85 PSIG

TROUBLESHOOTING SCHEMATIC

CAP SCREW GRADE IDENTIFICATION - MARKINGS ON HEAD



USE GRADE 2 TORQUES FOR STAINLESS STEEL FASTENERS AND CARRIAGE BOLTS.

CAP SCREW SIZE	TORQUE - FOOT-POUNDS					
	GRADE 2		GRADE 5		GRADE 8	
	DRY	LUBE	DRY	LUBE	DRY	LUBE
1/4"	5	4	8	6	12	9
5/16"	11	8	17	13	25	18
3/8"	20	15	30	23	45	35
7/16"	30	24	50	35	70	55
1/2"	50	35	75	55	110	80
9/16"	65	50	110	80	150	110
5/8"	90	70	150	110	220	170
3/4"	100	120	260	200	380	280
7/8"	140	110	400	300	600	460
1"	220	160	580	440	900	650

STANDARD TORQUES



IMPORTANT! Do not operate or work on machine without reading and understanding the operator's manual.

Before starting engine/before starting machine operation

- | | |
|--|---|
| <input type="checkbox"/> Program rate controller and document settings | <input type="checkbox"/> Hydraulic hoses are secured properly |
| <input type="checkbox"/> All stop, tail, and turn lights function properly | <input type="checkbox"/> Gearcase oil level is correct |
| <input type="checkbox"/> Tire pressures are equal on each side of chassis | <input type="checkbox"/> Safety shields in place |
| <input type="checkbox"/> Battery condition and connection | <input type="checkbox"/> Spinner Assy moves through full range of operation |
| <input type="checkbox"/> Electrical connections are tight and secure | <input type="checkbox"/> Spinner discs and fins installed properly |
| <input type="checkbox"/> All fasteners are secure | <input type="checkbox"/> Spinner discs and fins are in acceptable condition |
| <input type="checkbox"/> Inverted "V" is secure and installed properly | <input type="checkbox"/> Material Divider assembly is square and secure |
| <input type="checkbox"/> Sensor(s) are functioning properly | <input type="checkbox"/> Material Divider is clean of build-up |
| <input type="checkbox"/> Lubricate all grease fittings | <input type="checkbox"/> Feedgate assembly is level |
| <input type="checkbox"/> Hydraulic oil level and line connections are tight | <input type="checkbox"/> Encoder installed and secured |
| <input type="checkbox"/> Hydraulic filters are current and gauge is functional | <input type="checkbox"/> Spinner sensor adjusted to proper gap |
| <input type="checkbox"/> Chain oiler tank is full and operates correctly | |

Start engine/Start and run to operational temperatures

- | | |
|--|--|
| <input type="checkbox"/> Hydraulic fittings are tight, no leaks * | <input type="checkbox"/> Conveyor control valve is operating correctly |
| <input type="checkbox"/> Check operation of all alarms | <input type="checkbox"/> Calibrate radar/ground speed input |
| <input type="checkbox"/> Hydraulic flow test: ___ GPM @ operating engine RPM | <input type="checkbox"/> Test maximum conveyor(s) RPM |
| <input type="checkbox"/> Check main relief valve setting : ___ PSI | <input type="checkbox"/> Test right and left hand spinner speed; ensure difference is less than 30 RPM (when at operating RPM) |
| <input type="checkbox"/> | |

Stop operation/Turn off engine and engage parking brake

- | | |
|---|--|
| <input type="checkbox"/> Visually check for leaks | <input type="checkbox"/> All oil levels full |
| <input type="checkbox"/> Check belt/chain tension and alignment | |

Perform Calibrations

- | |
|---|
| <input type="checkbox"/> Product density testing, crush strength, and SGN scale (See <i>Spread Pattern Calibration</i> section for instructions). |
| <input type="checkbox"/> Catch tests <u>of all products and at least 1 blend</u> for conveyor calibration and document settings and product characteristics |
| <input type="checkbox"/> Spread pattern tests <u>of all products and at least 1 blend</u> and document settings and product characteristics |

End of Season

- | | |
|---|---|
| <input type="checkbox"/> Empty unit of all material | <input type="checkbox"/> Clean unit inside and out |
| <input type="checkbox"/> Sand and touch-up paint as necessary | <input type="checkbox"/> Check for leaks |
| <input type="checkbox"/> Wash chain conveyor, lubricate thoroughly when dry | <input type="checkbox"/> Lubricate all grease fittings |
| <input type="checkbox"/> Check spinner discs and fins for wear | <input type="checkbox"/> Ensure all fasteners are secure and properly torqued |

HYDRAULIC SYSTEM SERVICE VIDEOS



Click or Scan - Relief Valve Setup & Hydraulic Pump Pressure Test Procedure



Click or Scan - PWM Spinner Control Valve 12-Volt Override Procedure



Click or Scan - PWM Spinner Control Valve Manual Override Procedure



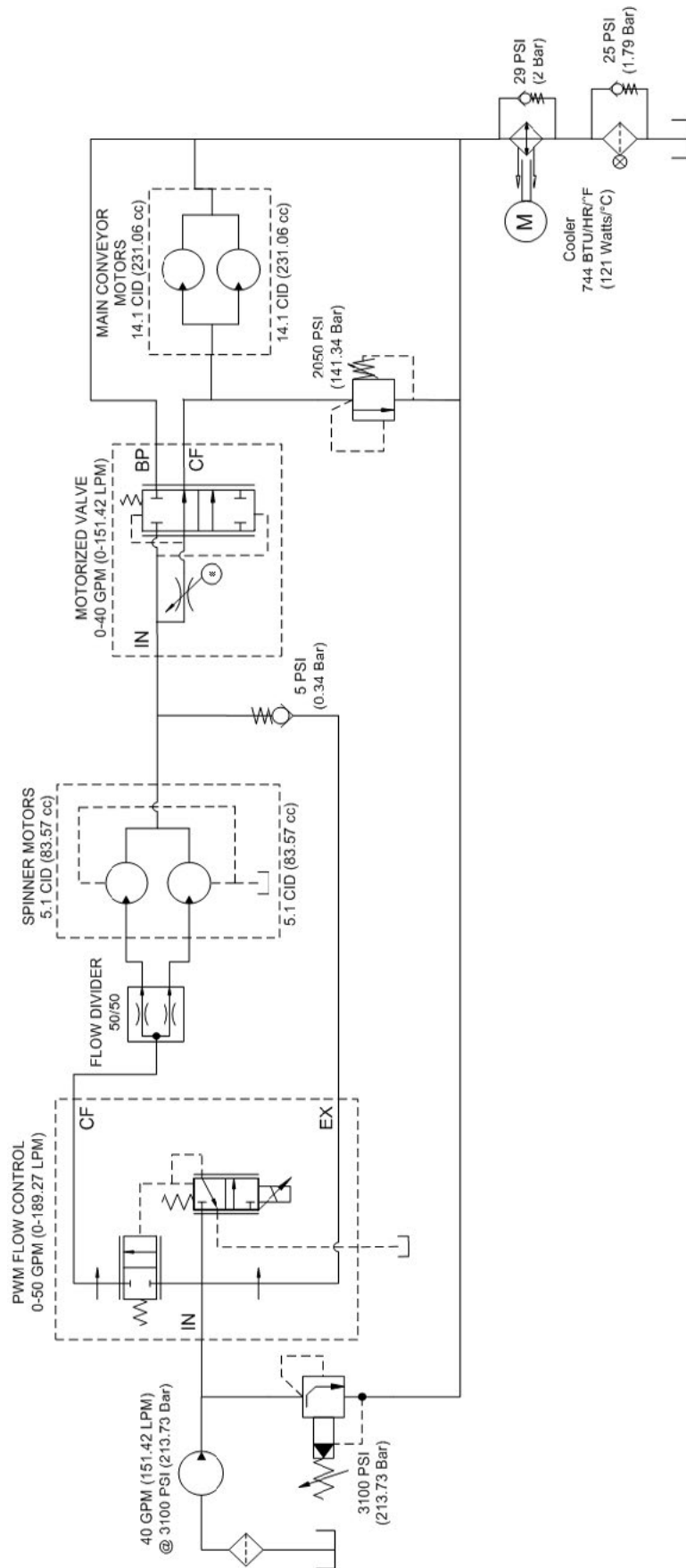
Click or Scan - New Leader Conveyor Control Valve Adjusting to Full Off Procedure

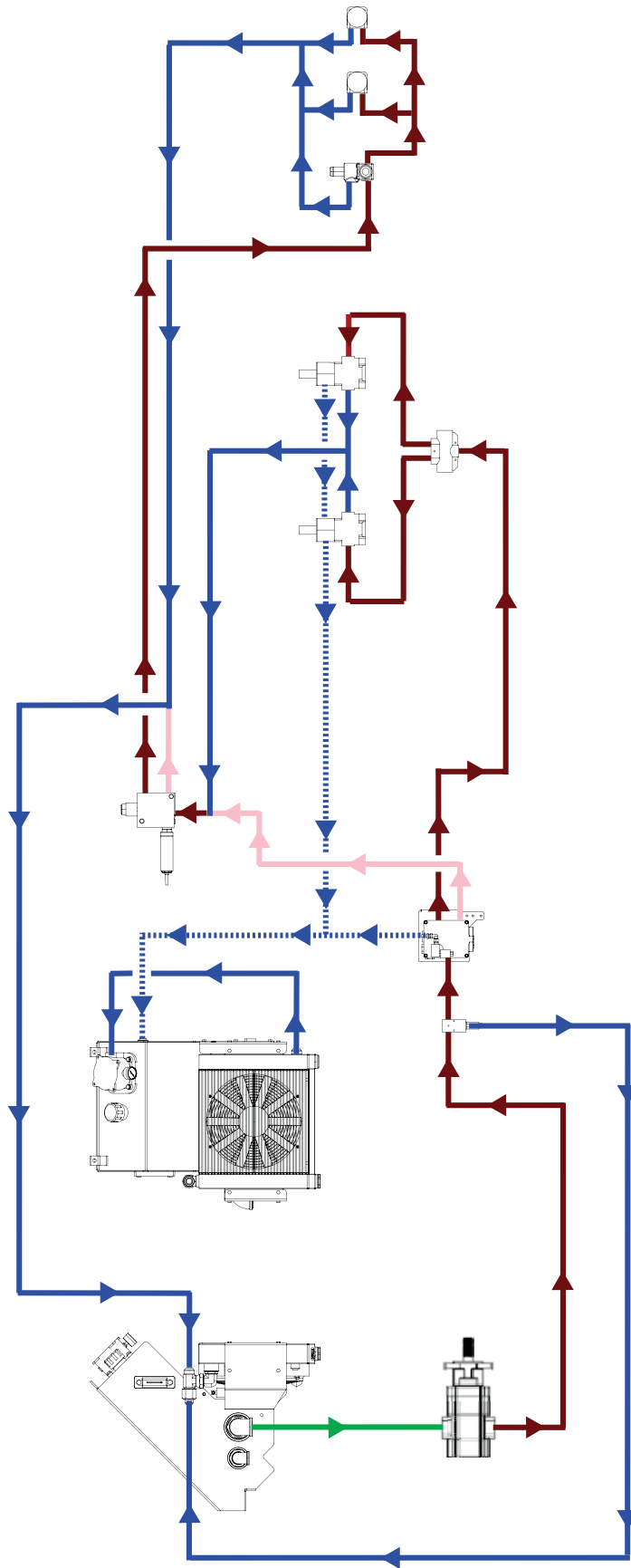


Click or Scan - Surging Conveyor Test

HYDRAULIC SCHEMATICS

The following pages contain representative hydraulic schematics for all configurations of the L4000G4 model spreader.

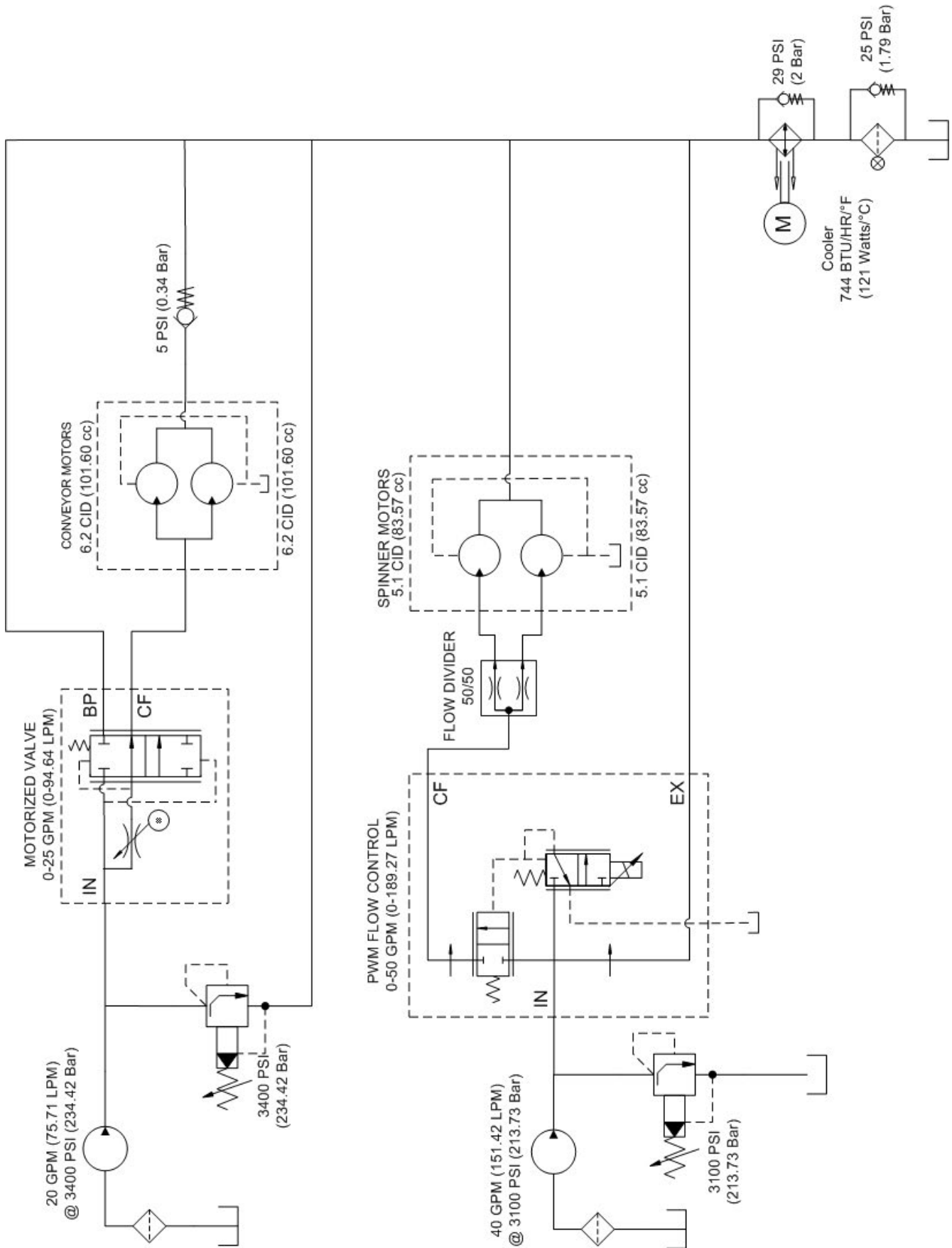


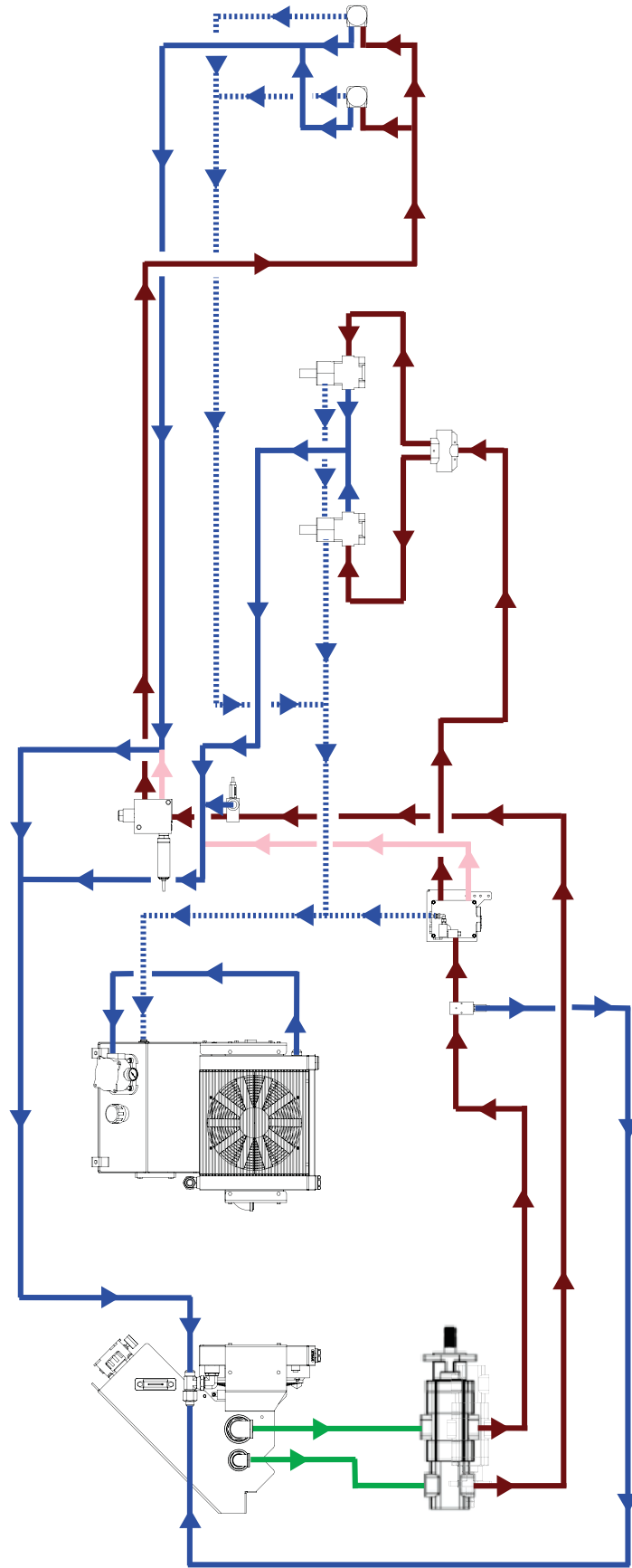


LEGEND

Red line	CONTROL FLOW (HIGH PRESSURE)
Light red line	EXCESS FLOW (HIGH PRESSURE)
Blue line	RETURN FLOW (LOW PRESSURE)
Dotted blue line	CASE DRAIN (LOW PRESSURE)
Green line	SUCTION FLOW (LOW PRESSURE)
Dotted orange line	PRESSURE ONLY (HIGH PRESSURE)

HYDRAULICS

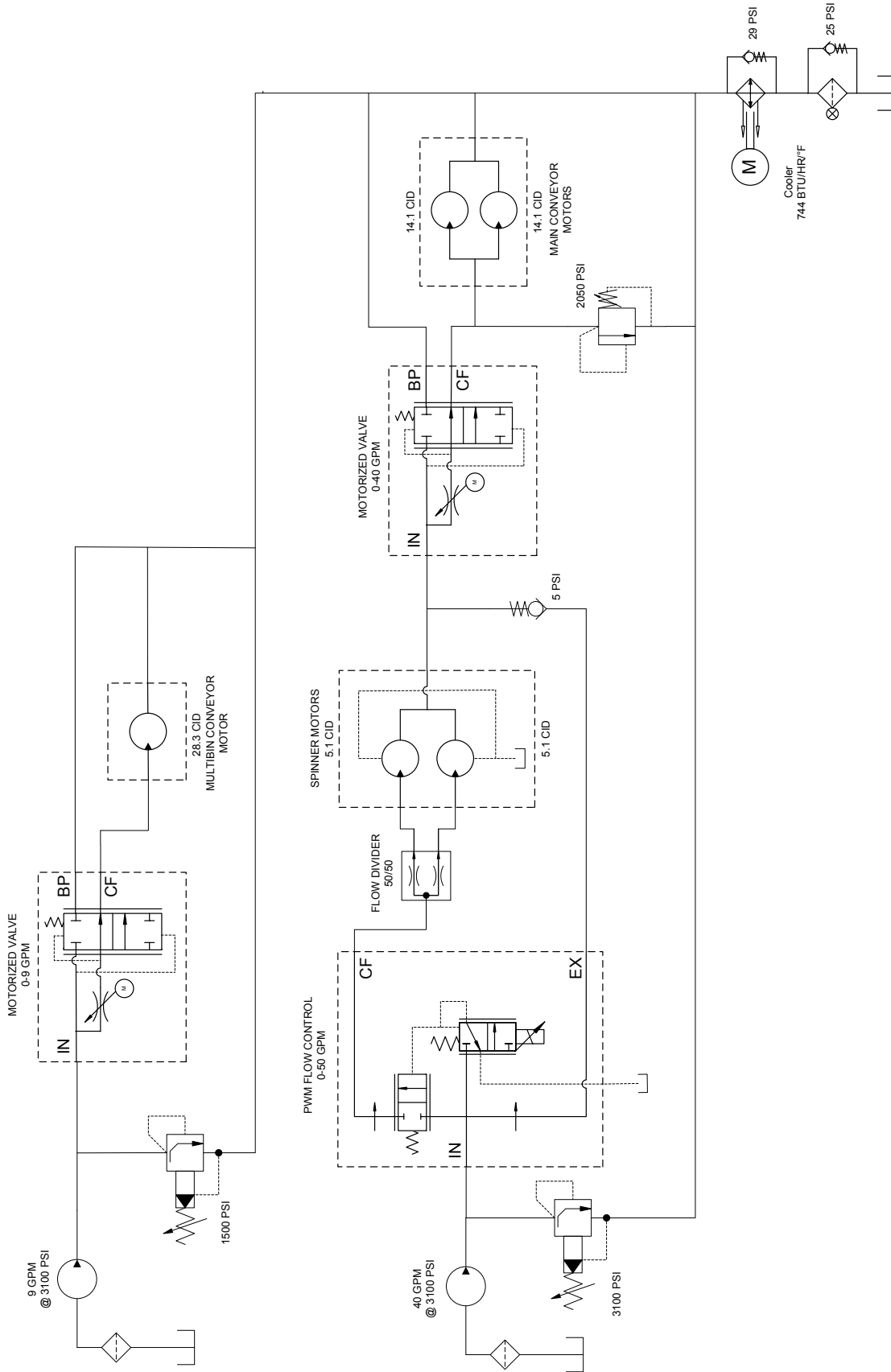


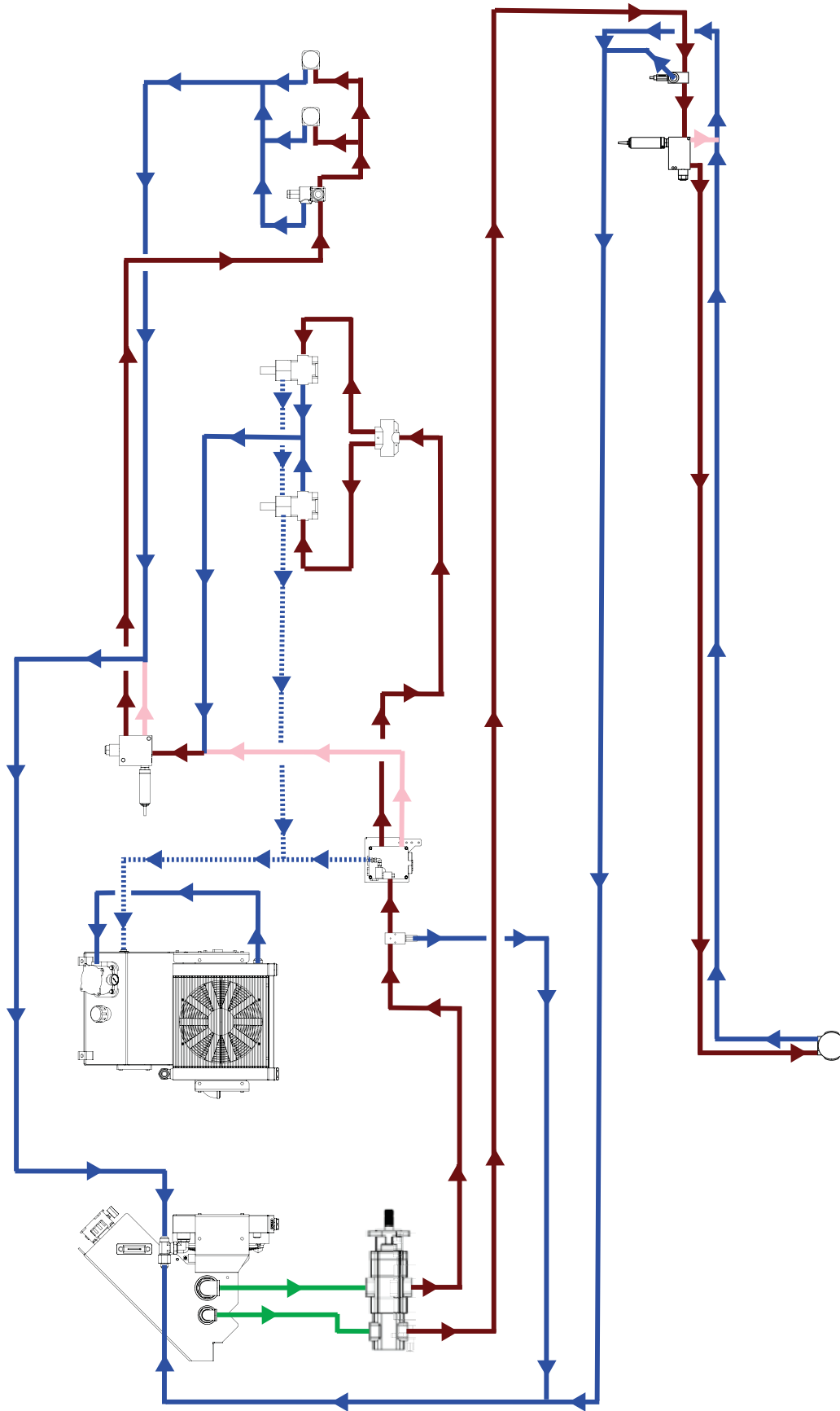


LEGEND

	CONTROL FLOW (HIGH PRESSURE)
	EXCESS FLOW (HIGH PRESSURE)
	RETURN FLOW (LOW PRESSURE)
	CASE DRAIN (LOW PRESSURE)
	SUCTION FLOW (LOW PRESSURE)
	PRESSURE ONLY (HIGH PRESSURE)

HYDRAULICS

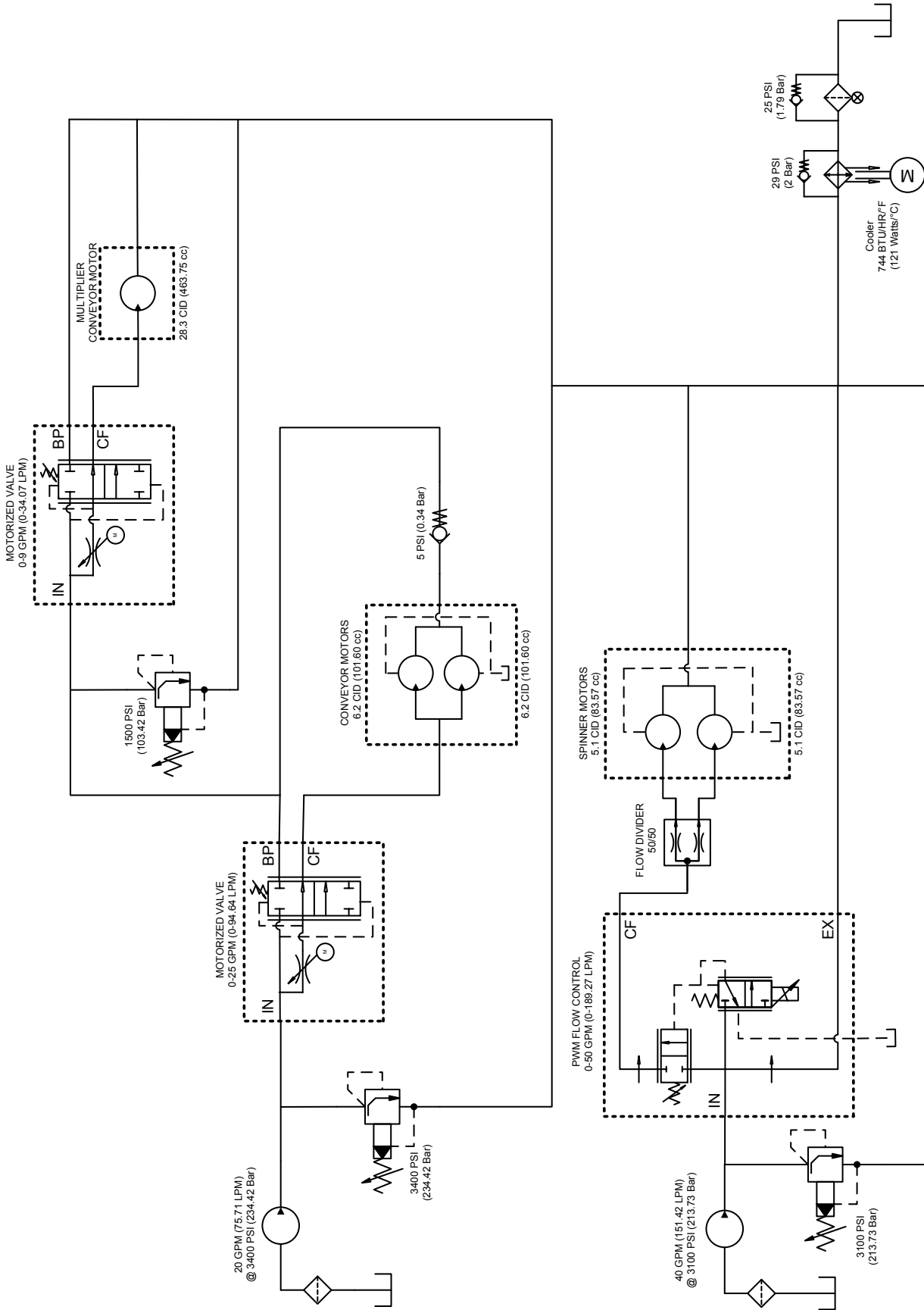




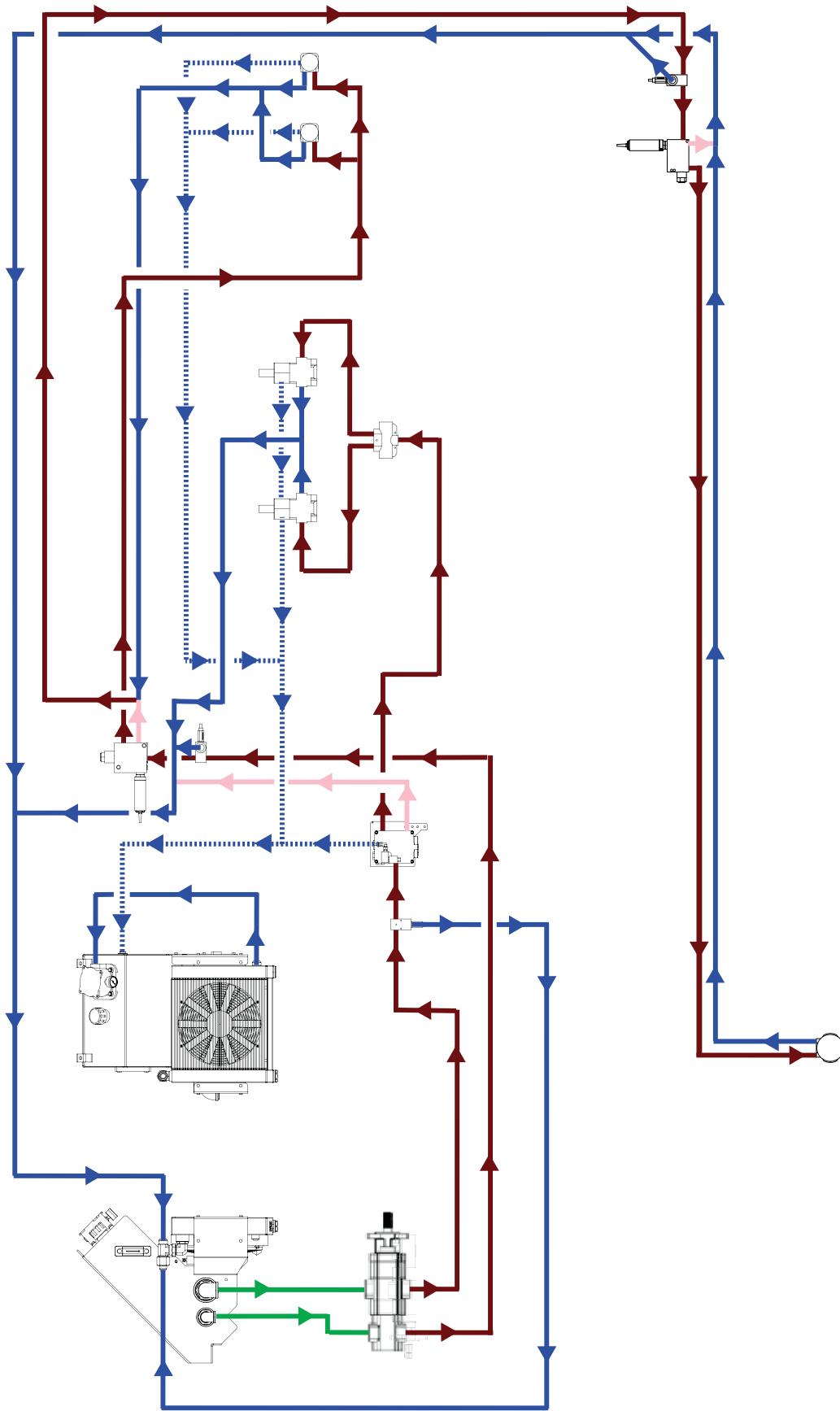
LEGEND

	CONTROL FLOW (HIGH PRESSURE)
	EXCESS FLOW (HIGH PRESSURE)
	RETURN FLOW (LOW PRESSURE)
	CASE DRAIN (LOW PRESSURE)
	SUCTION FLOW (LOW PRESSURE)
	PRESSURE ONLY (HIGH PRESSURE)

HYDRAULICS



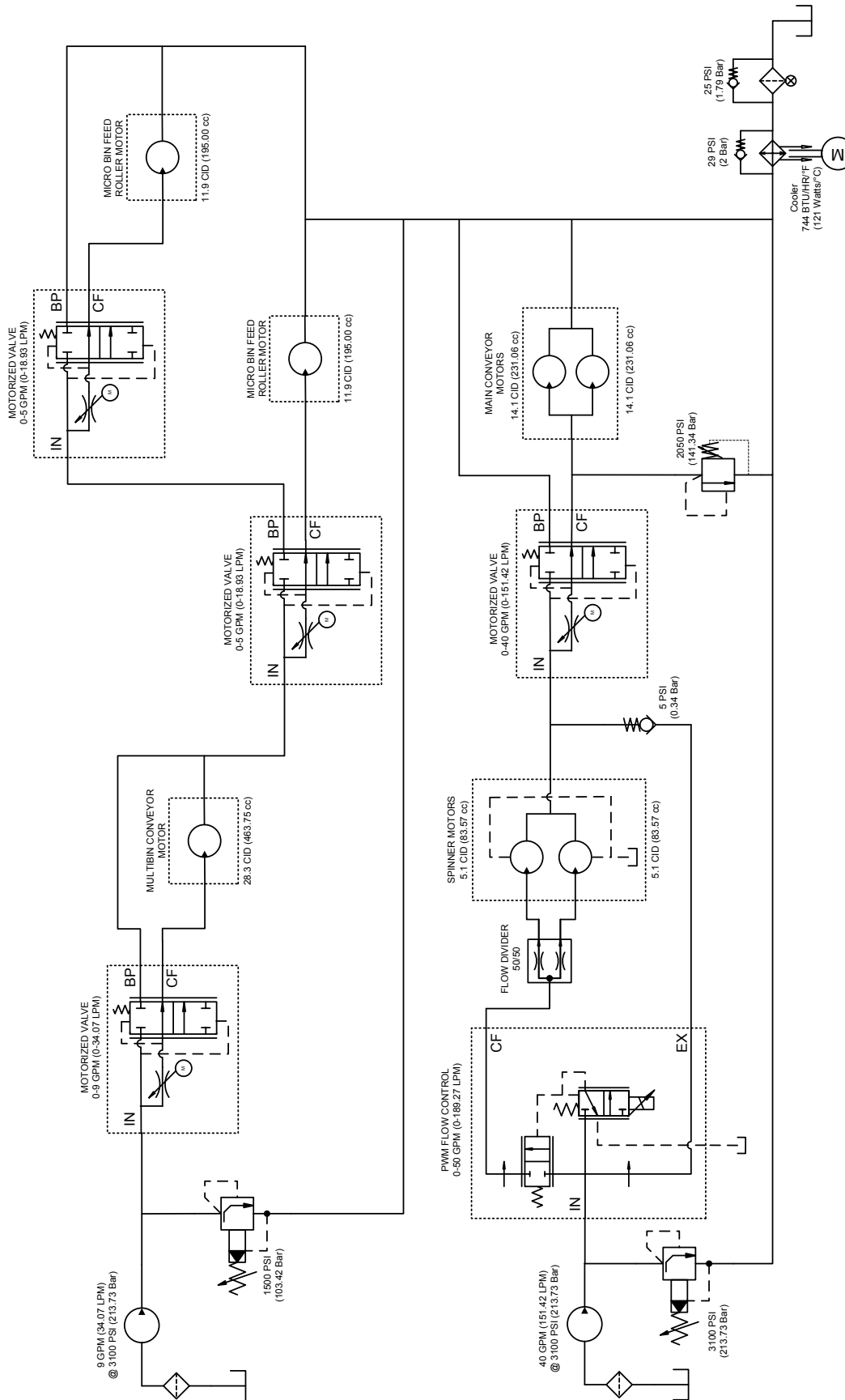
HYDRAULICS

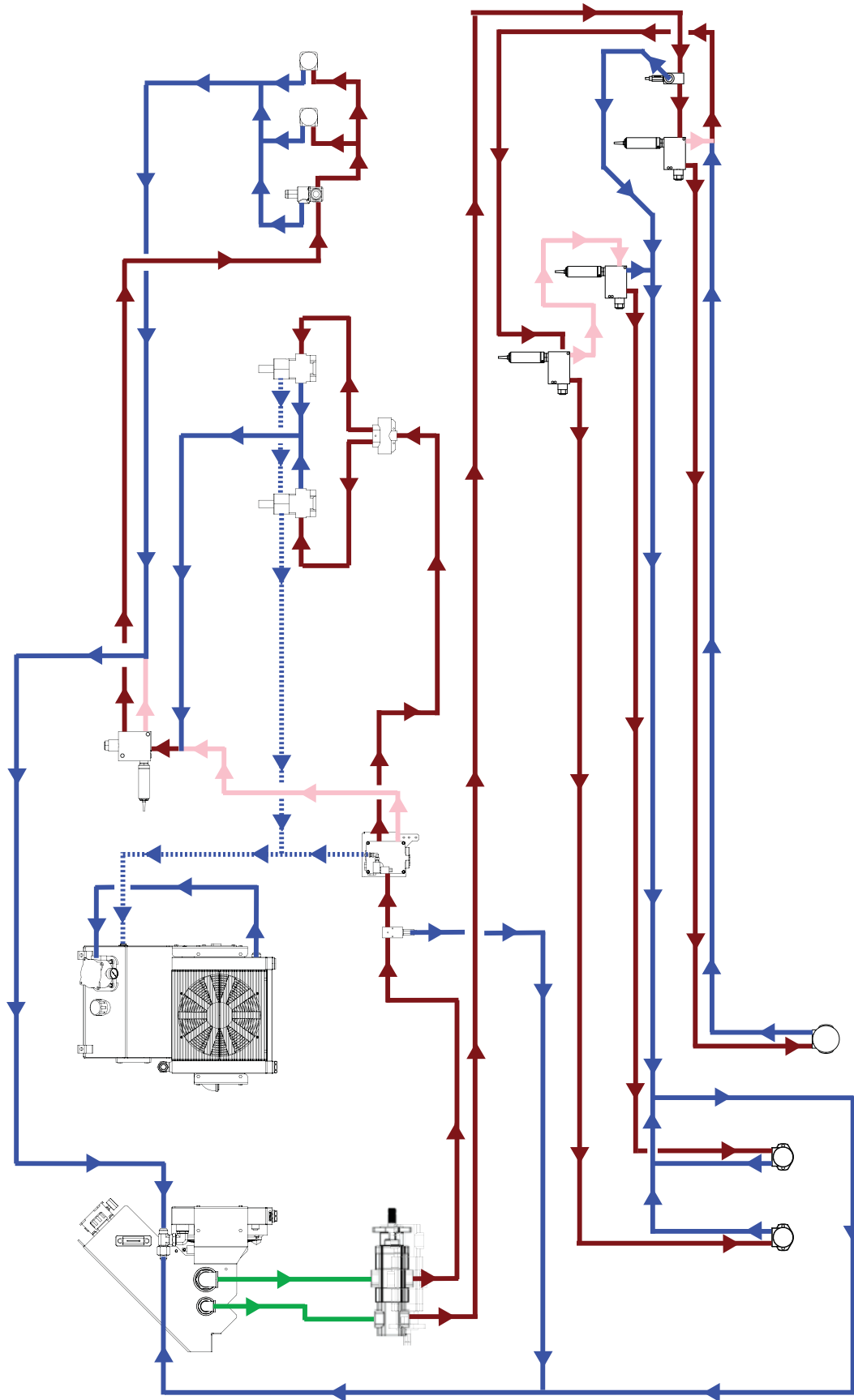


LEGEND

Red line	CONTROL FLOW (HIGH PRESSURE)
Blue line	EXCESS FLOW (HIGH PRESSURE)
Blue line	RETURN FLOW (LOW PRESSURE)
Dotted blue line	CASE DRAIN (LOW PRESSURE)
Green line	SUCTION FLOW (LOW PRESSURE)
Dotted orange line	PRESSURE ONLY (HIGH PRESSURE)

HYDRAULICS





LEGEND

	CONTROL FLOW (HIGH PRESSURE)
	EXCESS FLOW (HIGH PRESSURE)
	RETURN FLOW (LOW PRESSURE)
	CASE DRAIN (LOW PRESSURE)
	SUCTION FLOW (LOW PRESSURE)
	PRESSURE ONLY (HIGH PRESSURE)

HYDRAULICS

This page is intentionally left blank.

NOTES

The following information will guide you through using the SGN & Crush Strength Test Kit for your New Leader G4 Spreader. Refer to operator's manual for details on unit safety, operation and maintenance.

PART NUMBER	DESCRIPTION	QUANTITY
308907	Kit - SGN & Crush Strength Test Kit	1
308908	Tester - Crush Strength	1
308909	Scale - SGN	1

**WARNING**

Use great caution while working around the spreader. Contact with spinners and other moving parts is very dangerous. Do not adjust while machinery is moving, wear eye protection and avoid discharge from spinners. Do not ride on moving spreader.

It is highly recommended to perform a Catch Test, Crush Strength Test and SGN Scale Test prior to each season, before using a new product, or if a significant visible change has occurred with a product. Testing will define granular characteristics and help determine proper spinner settings for optimal product spread.

Conduct a G4 Spread Pattern test to check settings based on test results. Refer to *G4 Spreader Installation Instructions* and *G4 Spread Pattern Manual* for installation and adjustment instructions.

CRUSHING STRENGTH

Crushing strength is the minimum pressure needed to crush individual particles.

Testing and knowing the crushing strength of a particular product will help determine maximum spinner RPM. For example: Any granule with less than three (<3) crush strength should not be broadcast with spinner speeds over 700RPM. Verify granules are not pulverized before increasing spinner speed. Refer to *Product Setup Guidelines* for additional spinner speed settings with different crush strength.

SGN

SGN (Size Grade Number) is the measurement of granule size in millimeters multiplied by 100. A product's SGN will affect spread width.

Materials with poor uniformity (a significant percentage in 3 or more columns of scale device) may be difficult to spread accurately. Spread Pattern testing should ALWAYS be performed on any new or different material to determine actual spread width.

CATCH TEST

The CFR number, or cubic feet per revolution number, is a calibration constant entered into the controller to determine rate output from the spreader's conveyor. A catch test is performed to verify accurate rate output per the controller.

NOTE: SGN and Crush Strength together determine spread width.

General Rules:

A small product with low crush strength will have limited spread width capabilities. Spinner RPM must remain lower to keep from pulverizing the soft product, limiting your overall spread width. Additionally, a smaller product has less mass than that of a larger product, and in this case is another limiting factor for overall spread width.

A small product with high crush strength will have limited spread width capabilities. While spinner RPM can be increased with little worry of pulverizing the product, a smaller product has less mass than that of a larger product, which limits how far the product will carry in the spread pattern.

A large product with low crush strength will have limited spread width capabilities. While a larger product with more mass will carry farther, spinner RPM must remain lower to keep from pulverizing the soft product, limiting the overall spread width.

A large product with high crush strength has minimal spread width limitations. Spinner RPM can be increased with little worry of pulverizing the product. Additionally, a large product has more mass than that of a smaller product, allowing the product to carry farther, resulting in a wider spread width.

PRODUCT SETUP GUIDELINES

Granule Mesh	Crush Strength	Maximum Spinner RPM	Flotation Machine (Spinner Height 52") Spread Width ft(m)	Post Machine (Spinner Height 72") Spread Width ft(m)
140-200	1	600	60-65(18-20)	70-75(21-23)
	3	650-700	65-70(20-21)	75-80(23-24)
	6	750-800	70-75(21-23)	80-85(24-26)
	8	850-900	75-80(23-24)	85-90(26-27)
220-300	1	600	70-75(21-23)	80-85(24-26)
	3	650-700	75-80(23-24)	85-90(26-27)
	6	750-800	80-85(24-26)	90-95(27-29)
	8	850-900	85-90(26-27)	95-100(29-30)
320-400	1	600	80-85(24-26)	90-95(27-29)
	3	650-700	85-90(26-27)	95-100(29-30)
	6	750-800	90-95(27-29)	100-105(30-32)
	8	850-900	95-100(29-30)	105-110(32-33)
>400	1	600	90-95(27-29)	100-105(30-32)
	3	650-700	95-100(29-30)	105-110(32-33)
	6	750-800	100-105(30-32)	110-115(33-35)
	8	850-900	105-110(32-33)	115-120(35-37)

IMPORTANT! Always check crush strength prior to selecting spinner speed. Pan testing should ALWAYS be performed on any new or different material to determine actual spread width. Verify granules are not pulverized by looking in the three center vials following a pan test before increasing spinner speed.

CRUSH TESTClick or Scan -
Crush Test Procedure**IMPORTANT!**

Select granules of the most typical size and uniform shape as determined by SGN scale. Crushing strength can significantly increase with particle size.

**Figure 1**

1. Figure 1 - Place individual granule on solid, smooth surface.
2. Place New Leader crush strength tester over granule, open end flush with surface.

Ensure marker is next to handle.

**Figure 2**

3. Figure 2 - With one hand on handle, press tester down until granule breaks.

**Figure 3**

4. Figure 3 - Release handle and note where marker rests on number scale. This is granule crushing strength.

For example, the marker in Figure 3 is between 3 and 4 on the scale. Thus, crushing strength is 3.5.

5. Repeat 10 times and average the values.

SGN SCALE TESTClick or Scan -
SGN Scale Test Procedure

The SGN scale is an instrument designed for simple screen test of fertilizer samples. A small box fitted with five sieves, it directly produces a size histogram of the test sample. From this, the SGN can be estimated.



Figure 4

1. Figure 4 - To determine SGN, place scale on flat surface and open lid.
2. Fill end column with selected product to fill line.
3. Close lid securely.

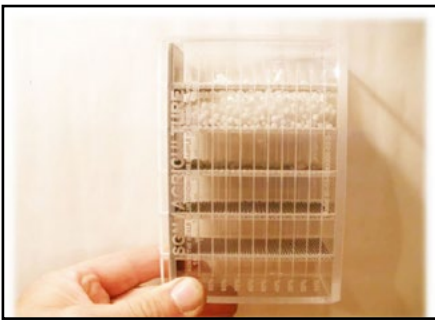


Figure 5

4. Figure 5 - Rotate scale vertical and shake to separate material, usually less than two minutes.
5. When material finishes dispersing, turn scale to starting position.

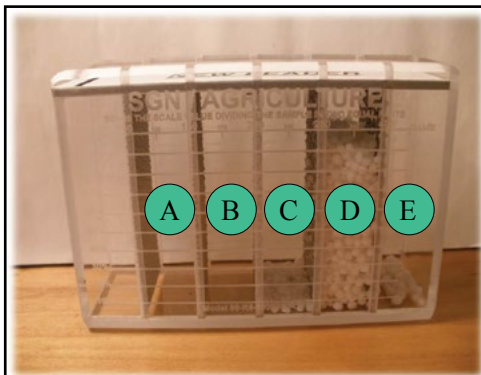


Figure 6

6. Figure 6 - View level of material in each compartment and determine SGN level based on markings.

SPREAD PATTERN TESTING CONTINUED

SGN
Size Grade Number

View each column for percentage

- Column A (120) = 0 material
- Column B (170) = 0 material
- Column C (240) = 5% of 240 equals 12
- Column D (340) = 90% of 340 equals 306
- Column E (400+) = 5% of 400 equals 20
- Total: 12+306+20 = 338 as average SGN

7. Figure 7 - Based on column headings and percent in each field, calculate overall SGN of the sample.

Figure 7

Using the above crush strength example of 3.5 and average SGN size of 338, we can now use the chart to determine our maximum spread width. In this case a maximum spinner speed of 650-700 RPM will produce a spread width of 85' to 100' depending on spinner height.

Granule Mesh	Crush Strength	Maximum Spinner RPM	Flotation Machine (Spinner Height 52") Spread Width ft(m)	Post Machine (Spinner Height 72") Spread Width ft(m)
320-400	1	600	80-85(24-26)	90-95(27-29)
	3	650-700	85-90(26-27)	95-100(29-30)
	6	750-800	90-95(27-29)	100-105(30-32)
	8	850-900	95-100(29-30)	105-110(32-33)

SGN & CRUSH STRENGTH TESTING

CATCH TEST

Click or Scan -
Catch Test Procedure
Ag Leader



Click or Scan -
Catch Test Procedure
Raven



NOTE: An optional calibration chute (P/N 312688) is available to simplify the catch test process. The calibration chute fits all New Leader spreader models with 30" wide conveyor bottoms. Contact your local New Leader dealer for details.

**WARNING**

To prevent injury, disable the spinners by unplugging the PWM valve before beginning the catch test procedure.

1. Disable the spinners by unplugging the PWM valve.
2. Move the spinner assembly to the 4" (10.2cm) position on the indicator by cranking the handle.
3. Remove the Material Divider back plate, and if available, install calibration chute.
4. Position an end loader or other suitable device beneath the spinners to catch material.
5. Load material into all applicable bins.
6. Prime the conveyor as specified per the controller.
 - If using a calibration chute, run the conveyor just until material reaches the end. Remove any excess material that falls into the catching device.
 - If not using a calibration chute, run the conveyor until the spinner discs are full of material. Remove any excess product from the catching device. Do not remove material from spinner discs.
7. Measure the depth of material on the end of the conveyor to verify the constant number feedgate height information entered into the controller. Adjust feedgate height as necessary.
8. Verify that all other product settings entered into the controller are correct.
9. Select the correct channel/node in the controller for the first bin to be tested. Enter the anticipated weight of product to be dispensed from the conveyor.
10. Start the engine and engage PTO. Allow to run for several minutes to bring hydraulic oil up to operating temperature. Bring engine up to operating RPM.
11. Following the setup wizard on the controller, run the catch test. The conveyor will start dispensing material, and automatically shut off when the estimated amount of product is dispensed.
12. If not using a calibration chute, leave the material on the spinner discs. Weigh the amount of product that the conveyor actually dispensed into the catching device, and note the result.
13. Enter the actual weight of material dispensed into the controller. The controller will then automatically perform the calibration.
14. Repeat Steps 5 - 12 for all other applicable bins, if a MULTAPPLIER or MULTIBIN is equipped.
15. Once satisfactory results have been achieved for all applicable bins, turn the engine off, replace the back plate on the Material Divider, return the spinner assembly to its original position setting, and plug the PWM valve back in.

NOTE: For more information on controller operations and setup, contact your local dealer.

**WARNING**

Use great caution while working around the spreader. Contact with spinners and other moving parts is very dangerous. Do not adjust while machinery is moving, wear eye protection and avoid discharge from spinners. Do not ride on moving spreader.

It is recommended that spread pattern tests be conducted prior to each spreading season, after any spreader maintenance, and periodically during the spreading season. Spread pattern tests must be performed for each product and application rate.

Spread pattern is affected by many factors. Among the more significant of these are:

- Spinner speed
- Material density
- Material granule size
- Material flow characteristics
- Rate of material delivery
- Point of material delivery on spinner discs
- Angle of the distributor fins on the spinner discs
- Cleanliness of the spinner fins and discs
- Wind and humidity
- Spacing of swaths
- Wear on spinner fins

Since many of these factors will vary for each job, trial and experience must be used to determine the adjustments required to obtain the spread width and spread pattern desired. The following instructions outline the adjustments available and the effect that each will have on the spread pattern.

SPREAD PATTERN TEST KIT

300508 Spread Pattern Test Kit, includes the following:

<u>PART NO.</u>	<u>DESCRIPTION</u>	<u>QTY</u>	<u>PART NO.</u>	<u>DESCRIPTION</u>	<u>QTY</u>
70890	Collection Tray	21	99418	Data Sheets	100
87200	Divider	21	300503	Screw – #6-32 x 3/8	42
300506	Rack – Tube	1	300504	Nut – Lock #6-32	42
300507	Test Tubes	21	70897	Flags	5
300505	Clip – Molded	21	87199	Rope – 120' marked	1
87332	Funnel	1	87201	Stakes	2
58897	Scale – Density	1			

SPINNERS

NOTICE! Spinner discs and fins must be kept clean and polished. Even a small build-up on a spinner fin can significantly affect the spread pattern. Rusty, rough, bent or worn fins will produce poor spread patterns.

Spinner speed is adjustable from approximately 400 to 900 RPM. This is accomplished by changing the settings in the controller. Proper spinner speed adjustment is very important in obtaining optimal spread patterns. The best spinner speed to use will depend entirely on the material being spread, and must be determined by testing.

A major factor of maximum pattern width is particle size. Pattern width may vary anywhere from 25 feet (7.6 m) for very finely ground dry lime up to 120 feet (37 m) or more for extremely large fertilizer pellets.

For every material there is a critical spinner speed. In other words, there is a speed which will result in the maximum obtainable spread width. Going beyond this speed will not increase spread width, but will result in a poor pattern.

Too high of a spinner speed could result in a heavy deposit behind the truck due to break-down of material. This upper speed limit will be quite low for finely powdered material, and can be quite high for extremely coarse materials. In general, this critical speed will fall somewhere between 600 and 800 RPM for typical materials.

It is recommended that a spread pattern test be performed for each product and application rate you handle. Once initial testing is completed, testing should be repeated at the beginning of every season, or any time maintenance is performed on any component affecting spread patterns.

SPREADER PREPARATION

The spreader to be tested shall be in good mechanical condition and properly adjusted according to the Operation and Maintenance sections in this Manual.

All damaged and worn parts must be replaced. Spinner discs and fins must be free of any material build-up, rust or paint.

Fill the hopper with the material to be spread. Run the material out to the end of the conveyor.

Set the feedgate to deliver the required rate per acre. Make sure the feedgate is level and the indicator reflects the actual gate opening measured by standing a tape measure vertically in the fertilizer.

NOTE: Do not match slope of endgate when making this measurement.

Adjust the spinner assembly by turning the crank or, if an actuator is installed, change the setting in the controller. To begin testing, position the spinner according to the chart below.

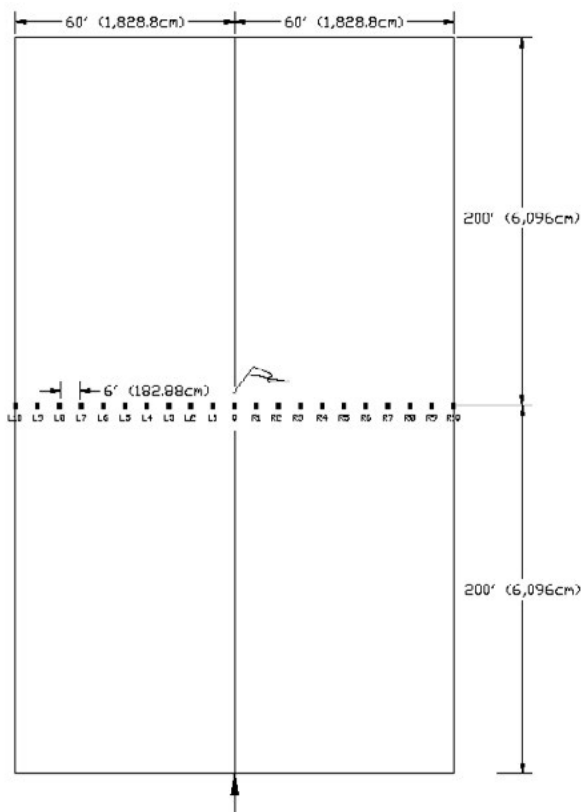
NOTE: This chart is to be used as a reference only to begin testing.

MATERIAL	DENSITY lbs/cu ft (kg/cu m)	SPINNER ASSEMBLY POSITION in (cm)
Lime	80-100 (1281-1601)	0 - 1 (0 - 2.5)
Fertilizer	65 (1040)	3.5 - 3.75 (9 - 9.5)
Urea, Light Rate - 50-200 lb/acre (56-224 kg/hectare)	48 (769)	3.5 - 3.75 (9 - 9.5)
Urea, Heavy Rate - >200 lb/acre (>224 kg/hectare)		2.0 - 2.5 (5 - 6.5)
Mixed Product, MultApplier	65 (1040)	3.75 (9.5)

TEST PROCEDURE

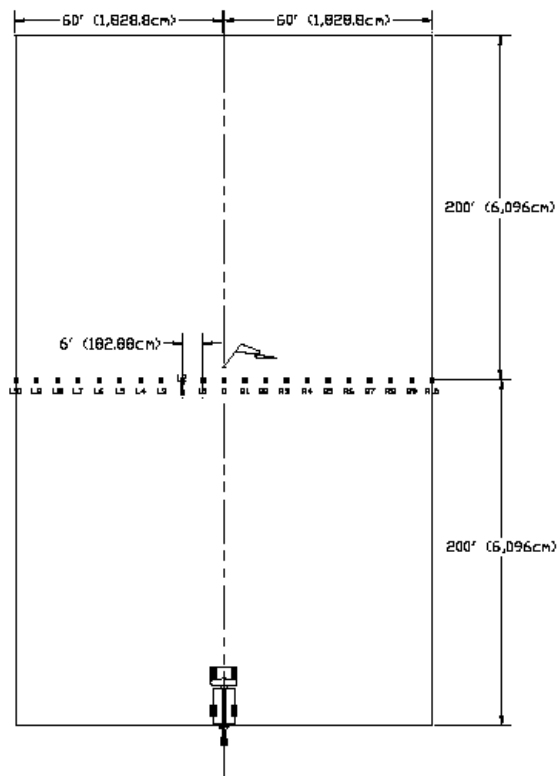
The area selected for testing, measuring 120 feet x 400 feet (37 m x 122 m), should have a slope of less than two degrees.

Insert a plastic grid into each of the 21 collection trays. Position the 21 collection trays on six-foot (6') (182.88cm) centers with the longest dimension of the tray parallel to the direction of travel. (Figure 1A)



DIRECTION OF TRAVEL
COURSE SET UP FOR PATTERN TEST

Figure 1A – Tray Positions



DIRECTION OF TRAVEL
COURSE SET UP FOR PATTERN TEST

Figure 1B – Spreader Position

All testing should be done when the wind velocity is less than 5 MPH (8.05 km). If wind is present, testing must be done with spreader traveling parallel (within ± 15 degrees) to the wind direction.

Do not allow loaded spreader to sit for more than four hours prior to testing.

Prior to driving the spreader through the test course, it should be driven at least 450 feet (137 m) at spreader test speeds.

Spreader must be driven over the collection trays in ONLY ONE DIRECTION.

Position spreader at the beginning of the course so that vehicle will straddle center collection tray. (Figure 1B) Set gate opening based on desired rate/acre according to theoretical application charts supplied with each unit.

Drive spreader completely through course at normal operating speeds.

DATA RECORDING

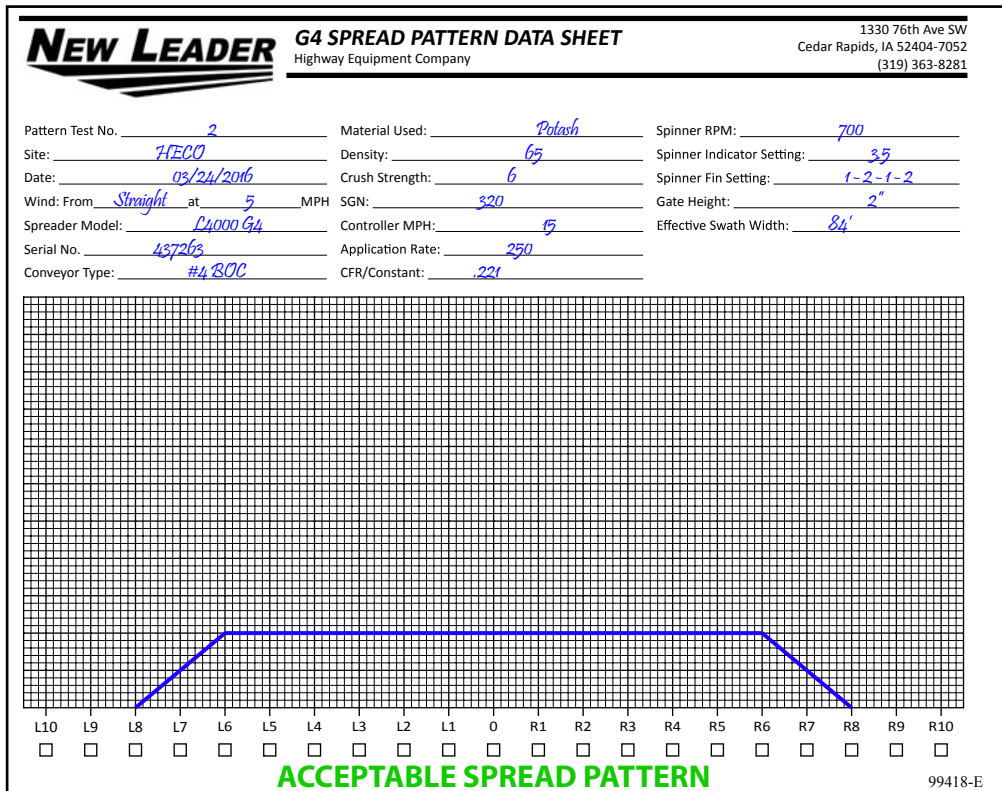
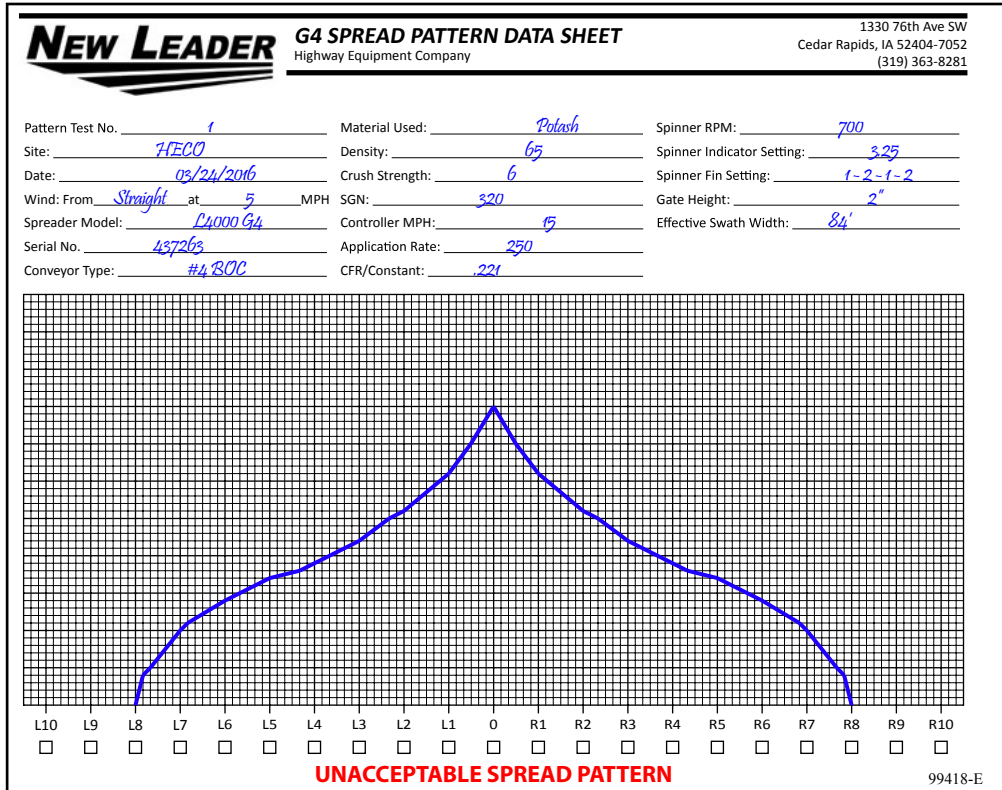


Figure 2 – Spread Pattern Data Sheet Example

SPREAD PATTERN

Using the data sheets supplied with the kit, document all spreader adjustments required.

Using the funnel, transfer the contents of each collection tray into its corresponding test tube beginning at one end of the trays and working towards the opposite end.

Record the volume in each test tube in the box on the data sheet under the corresponding tray position. (Figure 2) NOTE: It is highly recommended that ONLY ONE ADJUSTMENT be made between test samples taken. If more than one adjustment is made, it will be difficult to determine which adjustment was responsible for the change in pattern shape.

Once a desirable pattern is obtained (Figure 5), optimum driving centers can be determined. To determine optimum driving centers (effective swath width), locate the points on both the left and right side of the pattern where the amount of material applied is half the amount at the center of the pattern. The distance between these two points represents the driving centers to be used.

When blended fertilizers are being applied, a visual inspection of the samples should be made to determine whether the blend within the effective swath width is consistent with the desired blend. If the blend is not consistent, a narrower overall swath width should be used and a new optimum driving center (effective swath width) should be determined.

Once the effective swath width has been established, a change in the controller may be required.

DRIVING METHODS

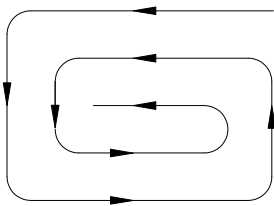


Figure 3 – Perimeter Method

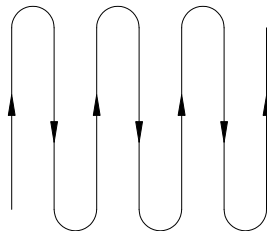


Figure 4 – Switch Back Method

The perimeter (Figure 3) and switch back (Figure 4) driving methods are both acceptable. NOTE: Utilizing the switch back method amplifies non-symmetrical patterns by blending right side on right and left side on left. The perimeter method compensates for non-symmetrical patterns by blending the right side of the pattern with the left side of the adjacent pattern or vice versa.

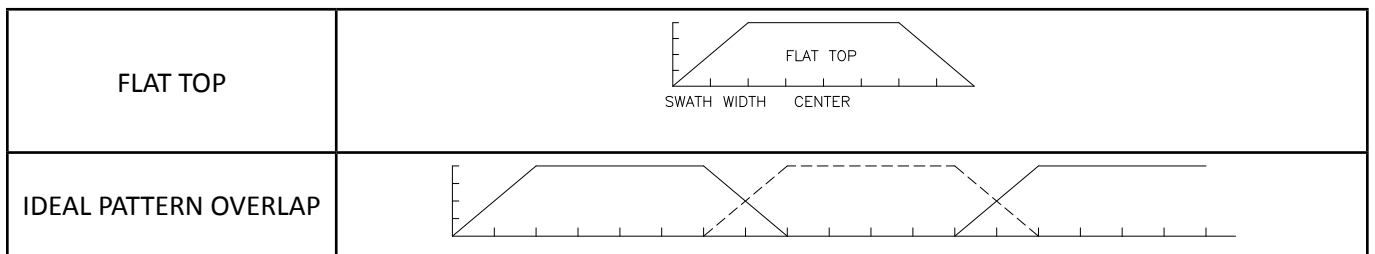


Figure 5 – Ideal Pattern

TROUBLESHOOTING

Problem	Pattern	Recommended Adjustments
Heavy Directly Behind the Vehicle		<ol style="list-style-type: none"> 1. Move the spinner forward (toward the conveyor). 2. Decrease spinner RPM. 3. Check spinner fin quality. 4. Move one or two spinner fins to a lower numbered hole.
Light Directly Behind the Vehicle		<ol style="list-style-type: none"> 1. Move the spinner rearward (away from conveyor). 2. Increase spinner RPM. 3. Check spinner fin quality. 4. Move one of two spinner fins to a higher numbered hole.
Light Outside Vehicle's Tire Tracks		<ol style="list-style-type: none"> 1. Check spinner fin quality. 2. Decrease spinner RPM. 3. Move one or two spinner fins to a lower numbered hole.
Pattern Off Center		<ol style="list-style-type: none"> 1. Check to see feedgate is level and free of caked material. 2. Make sure hillside divider is mounted squarely and centered. 3. Check to be sure spinner assembly is mounted squarely and centered. 4. Make sure material divider is mounted squarely and centered. 5. Testing should be done parallel to wind.

SPREAD PATTERN