

NEW LEADER



MODEL JOHN DEERE 4 SERIES NL200G4 & NL300G4

UNIT SERIAL NUMBER _____

MULTIPLIER SERIAL NUMBER _____

MANUAL NUMBER: 309738-AA-E-01

EFFECTIVE 08/26/2016



Highway Equipment Company

Building the best since 1939.

1330 76TH AVE SW
CEDAR RAPIDS, IA 52404-7052
PHONE (319) 363-8281 | FAX (319) 286-3350
www.highwayequipment.com

Copyright 2013 Highway Equipment Company, Inc.

TABLE OF CONTENTS

Table of Contents.....	2
Interactive Features.....	4
Warranty.....	6
Preface.....	7
Safety.....	8
Safety Decals	9
Informational Decals	12
General Safety Rules.....	14
Installation Instructions.....	19
Hydraulic Requirements.....	19
Lifting the Spreader	20
Securing Spreader to Chassis.....	21
Hydraulics	22
Filling Hydraulic System	22
Hydraulic Hose Installation Guide.....	23
Electrical Connections.....	24
Light Installation	25
Tail Lights	25
Beacon Kit (Optional).....	25
MultApplier Style Comparison	27
Insert Installation Instructions.....	28
Spreader Preparation.....	28
Feedgate Adjustment.....	30
Hydraulics	34
Electrical Connections.....	34
Hillside Divider & Conveyor Cover	35
Insert Removal/Endgate Installation.....	36
General Description.....	37
Introduction.....	38
Dimensions & Capacities	42
Initial Startup.....	46
G4 Spinner Squaring	47
Field Testing.....	51
Operating Procedures.....	52
Lubrication & Maintenance.....	53
Preventative Maintenance Pays!	53
Hydraulic System.....	53
Service Schedule.....	53
Hydraulic Hose	54
Conveyor Chain	54
#4 BOC Conveyor Belt Maintenance.....	56
#5 Straight Belt Conveyor	57
Maintenance.....	57
Adjustment	58
Belt Shields	61
Removal & Replacement	61
Conveyor Gearcase	63
Bin Sensor	63
Lubrication of Bearings	63
Fasteners.....	63
Clean-Up	63



Lubricant & Hydraulic Oil Specifications..... 65

 Hydraulic System..... 65

 Gearcase Lubricant 65

 Grease Gun Lubricant 65

 Chain Conveyors 65

Lubrication & Maintenance Chart 66

Troubleshooting 68

Standard Torques 70

Hydraulics 73

 Hydraulic System Service Videos 73

 Hydraulic Schematics 73

Spread Pattern Testing..... 79

 Crushing Strength 79

 SGN 79

 Catch Test..... 79

 Product Setup Guidelines 80

 Crush Test 81

 SGN Scale Test 82

 Catch Test 84

 Performing a Spread Pattern Test 85

 Spread Pattern Test Kit 85

 Spinners 86

 Spreader Preparation 86

 Test Procedure 87

 Data Recording 88

 Driving Methods 89

 Troubleshooting..... 90

INTERACTIVE FEATURES**NOTE:**

This manual incorporates several interactive features to provide supplemental information and ease of navigation. The information below is to aid in the identification and use of these features.

Hyperlinks

Hyperlinks provide direct access to a specific destination when clicked. The entire Table of Contents of this manual is hyperlinked to provide quick access to all sections of this manual when viewing the electronic version.

Hyperlinks within the content are denoted by **blue, bold underlined text**. Electronic format viewers can click these links for direct access to New Leader online features. Internet access is required.

Quick Reference (QR) Codes

Quick reference codes provide direct access to a specific destination when activated. An example is provided below. In the printed version of this manual, viewers may scan the codes with a supporting mobile device for direct access to New Leader online features. Mobile data is required.

The electronic version of this manual provides the option to scan codes on-screen, or to click the code like a button. Internet access/mobile data is required.



Click or Scan - Highwayequipment.com



This page is intentionally left blank.

Insert Current New Leader
Warranty

PLEASE ! ALWAYS THINK SAFETY FIRST !!

The purpose of this manual is to familiarize the person (or persons) using this unit with the information necessary to properly install, operate, and maintain this system. The safety instructions indicated by the safety alert symbol in the following pages supersede the general safety rules. These instructions cannot replace the following: the fundamental knowledge that must be possessed by the installer or operator, the knowledge of a qualified person, or the clear thinking necessary to install and operate this equipment. Since the life of any machine depends largely upon the care it is given, we suggest that this manual be read thoroughly and referred to frequently. If for any reason you do not understand the instructions, please call your authorized dealer or our Product Sales and Support Department at 1-888-363-8006.

It has been our experience that by following these installation instructions, and by observing the operation of the spreader, you will have sufficient understanding of the machine enabling you to troubleshoot and correct all normal problems that you may encounter. Again, we urge you to call your authorized dealer or our Product Sales and Support Department if you find the unit is not operating properly, or if you are having trouble with repairs, installation, or removal of this unit.

We urge you to protect your investment by using genuine HECO parts and our authorized dealers for all work other than routine care and adjustments.

Highway Equipment Company reserves the right to make alterations or modifications to this equipment at any time. The manufacturer shall not be obligated to make such changes to machines already in the field.

This Safety Section should be read thoroughly and referred to frequently.

ACCIDENTS HURT !!!

ACCIDENTS COST !!!

ACCIDENTS CAN BE AVOIDED !!!



SAFETY



TAKE NOTE! THIS SAFETY ALERT SYMBOL FOUND THROUGHOUT THIS MANUAL IS USED TO CALL YOUR ATTENTION TO INSTRUCTIONS INVOLVING YOUR PERSONAL SAFETY AND THAT OF OTHERS. FAILURE TO FOLLOW THESE INSTRUCTIONS CAN RESULT IN INJURY OR DEATH.

In this manual and on the safety signs placed on the unit, the words "DANGER," "WARNING," "CAUTION," and "NOTICE" are used to indicate the following:



DANGER

Indicates an imminently hazardous situation that, if not avoided, WILL result in death or serious injury. This signal word is to be limited to the most extreme situations and typically for machine components that, for functional purposes, cannot be guarded.



WARNING

Indicates a potentially hazardous situation that, if not avoided, COULD result in death or serious injury, and includes hazards that are exposed when guards are removed. It may also be used to alert against unsafe practices.



CAUTION

Indicates a potentially hazardous situation that, if not avoided, MAY result in minor or moderate injury. It may also be used to alert against unsafe practices.

NOTICE!

Is used for informational purposes in areas which may involve damage or deterioration to equipment but generally would not involve the potential for personal injury.

NOTE:

Provides additional information to simplify a procedure or clarify a process.

The need for safety cannot be stressed strongly enough in this manual. At Highway Equipment Company, we urge you to make safety your top priority when operating any equipment. We firmly advise that anyone allowed to operate this machine be thoroughly trained and tested, to prove they understand the fundamentals of safe operation.

The following guidelines are intended to cover general usage and to assist you in avoiding accidents. There will be times when you will run into situations that are not covered in this section. At those times the best standard to use is common sense. If, at any time, you have a question concerning these guidelines, please call your authorized dealer or our Product Sales & Support Department at (888) 363-8006.



SAFETY DECAL MAINTENANCE INSTRUCTIONS

1. Keep safety decals and signs clean and legible at all times.
2. Replace safety decals and signs that are missing or have become illegible.
3. Replaced parts that displayed a safety sign should also display the current sign.
4. Safety decals or signs are available from your dealer's Parts Department or our Cedar Rapids factory.

SAFETY DECAL INSTALLATION INSTRUCTIONS

1. Clean Surface
Wash the installation surface with a synthetic, free-rinsing detergent. Avoid washing the surface with a soap containing creams or lotion. Allow to dry.
2. Position Safety Decal
Decide on the exact position before application. Application marks may be made on the top or side edge of the substrate with a lead pencil, marking pen, or small pieces of masking tape. NOTE: Do not use chalk line, china marker, or grease pencil. Safety decals will not adhere to these.
3. Remove the Liner
A small bend at the corner or edge will cause the liner to separate from the decal. Pull the liner away in a continuous motion at a 180-degree angle. If the liner is scored, bend at score and remove.
4. Apply Safety Decal
 - a. Tack decal in place with thumb pressure in upper corners.
 - b. Using firm initial squeegee pressure, begin at the center of the decal and work outward in all directions with overlapping strokes. NOTE: Keep squeegee blade even—nicked edges will leave application bubbles.
 - c. Pull up tack points before squeegeeing over them to avoid wrinkles.
5. Remove Pre-mask
If safety decal has a pre-mask cover remove it at this time by pulling it away from the decal at a 180 degree angle. NOTE: It is important that the pre-mask covering is removed before the decal is exposed to sunlight to avoid the pre-mask from permanently adhering to the decal.
6. Remove Air Pockets
Inspect the decal in the flat areas for bubbles. To eliminate the bubbles, puncture the decal at one end of the bubble with a pin (never a razor blade) and press out entrapped air with thumb moving toward the puncture.
7. Re-Squeegee All Edges.



SAFETY DECALS CONTINUED

! DANGER



MOVING PART HAZARD
To prevent death or serious injury:

- Stay out of box while conveyor is moving.
- Disconnect and lockout power source before adjusting or servicing.
- Do not ride on spreader.

364-C

! DANGER



FLYING MATERIAL & ROTATING SPINNER HAZARD
To prevent death or serious injury:

- Wear eye protection.
- Stop machine before servicing or adjusting.
- Keep bystanders at least 60 feet away.

368-C

! WARNING



FALLING HAZARD
To prevent death, serious injury or machine damage:

- Do not stand or climb on guard.

55630-D

! WARNING



HIGH PRESSURE FLUID HAZARD
To prevent death or serious injury

- Do not check leaks with hands while system is operating as high pressure oil leaks can be dangerous!
- Relieve pressure before disconnecting hydraulic lines or working on system.
- Make sure all hydraulic fluid connections are tight and all hydraulic hoses and lines are in good condition before applying pressure to the system.
- Wear protective gloves and safety glasses or goggles when searching for leaks. Use wood or cardboard instead of hands.
- Do not use hydraulic lines for hand holds or steps.
- Components may be hot.
- Get immediate medical attention if skin is pierced with fluid as gangrene may result.

39138-D

! WARNING

MOVING PART HAZARD
To prevent death or serious injury:

- Close and secure guards before starting.
- Do not stand or climb on machine.
- Disconnect and lockout power source before adjusting or servicing.
- Keep hands, feet and hair away from moving parts.

55631-C

NO STEP

39017-D

SAFETY



SAFETY DECALS CONTINUED

! **DANGER**

GUARD IS MISSING WHEN THIS IS VISIBLE
To prevent death or serious injury:

- Do not operate this unit without guard in place.

308191-A

! **CAUTION**

HAZARDOUS MATERIALS
To avoid injury or machine damage:

- Materials to be spread can be dangerous.
- Improper selection, application, use or handling may be a hazard to persons, animals, crops or other property.
- Follow instructions and precautions given by the material manufacturer.

321-C

! **CAUTION**

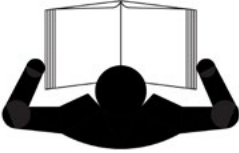

TO AVOID INJURY OR MACHINE DAMAGE:

- Do not operate or work on this machine without reading and understanding the operators manual.
- Keep hands, feet, hair and clothing away from moving parts.
- Do not allow riders on machine.
- Avoid unsafe operation or maintenance.
- Disengage power takeoff and shut off engine before removing guards, servicing or unclogging machine.
- Keep unauthorized people away from machine.
- Keep all guards in place when machine is in use.
- If manual is missing, contact dealer for replacement.

150034-C

SAFETY



INFORMATIONAL DECALS

NOTICE

Before spreading material, spread pattern tests must be conducted to properly adjust the spread pattern. Refer to the manual for adjustment instructions. A spread pattern test kit is available from your New Leader dealer.

Wind, humidity, rain and other adverse weather conditions can affect spread pattern, resulting in uneven crop growth and loss of yields.

THE MANUFACTURER OF THIS SPREADER WILL NOT BE LIABLE FOR MISAPPLIED MATERIAL DUE TO AN IMPROPERLY ADJUSTED SPREADER OR ADVERSE WEATHER CONDITIONS.

It is recommended that spread pattern tests be conducted prior to each spreading season, after any spreader maintenance, and periodically during the spreading season. Spread pattern tests must be conducted whenever a new product is to be applied.

312276-A

NOTICE**DO NOT SPREAD HERBICIDE**

This unit is intended for dispensing micronutrients and seeds only--NOT HERBICIDES. The manufacturer is not liable for damage resulting from improper use.

304206-B

NOTICE

- Conveyor chain life will be noticeably extended by periodic lubrication.
- Use a 75% diesel fuel and 25% number 10 oil mixture on the links and rollers.
- Failure to keep the chain links loose and free running can result in severe damage to the conveyor chain, drag shaft, gear case, body structure, and is cause for voiding the warranty.

21476-E



INFORMATIONAL DECALS CONTINUED

NOTICE		
	No Cooler	With Cooler
Ideal Operating Temp	140 - 190°F	115 - 158°F
Recommended Lubricant	SAE 15W-40	Multi-Purpose Ag Hydraulic Oil
Lubricant Specifications:		
Viscosity Index	>130	>130
Viscosity at 40°C, cst	<115	<68
Viscosity at 100°C, cst	>14	>9
		304264-B

NOTICE

Change filter element.

After the first 50 hrs. and every 250 hrs. thereafter

39378-F

NOTICE

Keep valve open while pump is running.

↓

8664-D

1. Before attempting to operate this unit, read and be sure you understand the operation and maintenance manual. Locate all controls and determine the use of each. Know what you are doing!



2. When leaving the unit unattended for any reason, be sure to:
 - a. Take power take-off out of gear.
 - b. Shut off conveyor and spinner drives.
 - c. Shut off vehicle engine and unit engine (if so equipped).
 - d. Place transmission of the vehicle in "neutral" or "park".
 - e. Set parking brake firmly.
 - f. Lock ignition and take keys with you.
 - g. Lock vehicle cab.
 - h. If on steep grade, block wheels.

These actions are recommended to avoid unauthorized use, runaway, vandalism, theft and unexpected operation during start-up.

3. Do not read, eat, talk on a mobile phone or take your attention away while operating the unit. Operating is a full-time job.

4. Stay out of the spreader. If it's necessary to enter the spreader, return to the shop, empty body, turn off all power, set vehicle brakes, lock engine starting switch and remove keys before entering. Tag all controls to prohibit operation. Tags should be placed, and later removed, only by person working in the body.



5. Guards and covers are provided to help avoid injury. Stop all machinery before removing them. Replace guards and covers before starting spreader operation.

6. Stay clear of any moving members, such as shafts, couplings and universal joints. Make adjustments in small steps, shutting down all motions for each adjustment.



7. Before starting unit, be sure everyone is clear and out of the way.

8. Do not climb on unit. Use the inspection ladder or a portable ladder to view the unit. Be careful in getting on and off the ladder, especially in wet, icy, snowy or muddy conditions.

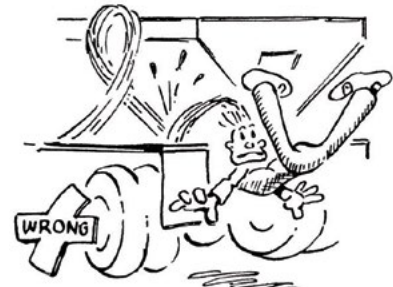

9. Do not allow anyone to ride on any part of unit for any reason.



9. Do not allow anyone to ride on any part of unit for any reason.

10. Keep away from spinners while they are turning:

- a. Serious injury can occur if spinners touch you.
- b. Rocks, scrap metal or other material can be thrown off the spinner violently. Stay out of discharge area.
- c. Make sure discharge area is clear before spreading.



- 11. Inspect spinner fins, spinner frame mounting and spinner fin nuts and screws every day. Look for missing fasteners, looseness, wear and cracks. Replace immediately if required. Use only new SAE grade 5 or grade 8 screws and new self-locking nuts.



- 12. Inspect all bolts, screws, fasteners, keys, chain drives, body mountings and other attachments periodically. Replace any missing or damaged parts with proper specification items. Tighten all bolts, nuts and screws to specified torques according to the torque chart in this manual.



- 13. Shut off engine before filling fuel and oil tanks. Do not allow overflow. Wipe up all spills. Do not smoke. Stay away from open flame. FIRE HAZARD!



- 14. Starting fluids and sprays are extremely flammable. Don't smoke. Stay away from flame or heat!



- 15. All vehicles should be equipped with a serviceable fire extinguisher of 5 BC rating or larger.

- 16. Hydraulic system and oil can get hot enough to cause burns. DO NOT work on system that

is hot. Wait until oil has cooled. If an accident occurs, seek immediate medical assistance.

- 17. Wear eye protection while working around or on unit.
- 18. Read, understand and follow instructions and precautions given by the manufacturer or supplier of materials to be spread. Improper selection, application, use or handling may be hazardous to people, animals, plants, crops or other property.



CAUTION If spreader is used to transport chemicals, check with your chemical supplier regarding DOT (Department of Transportation) requirements.



- 19. Cover all loads that can spill or blow away. Do not spread dusty materials where dust may create pollution or a traffic visibility problem.

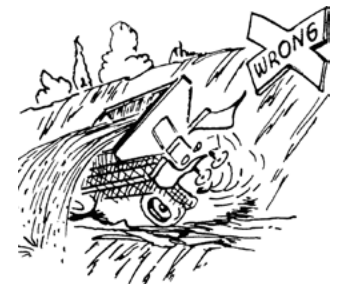

- 20. Turn slowly and be careful when traveling on rough surfaces and side slopes, especially with a loaded spreader. Load may shift causing unit to tip.

- 21. Read and understand the precautionary decals on the spreader. Replace any that become defaced, damaged, lost or painted over. Replacement decals can be ordered from your dealer's parts department or from Highway Equipment Company by calling (319) 363-8281.

1. Maintenance includes all lubrication, inspection, adjustments (other than operational control adjustments such as feedgate openings, conveyor speed, etc.) part replacement, repairs and such upkeep tasks as cleaning and painting.



2. When performing any maintenance work, wear proper protective equipment—always wear eye protection—safety shoes can help save your toes—gloves will help protect your hands against cuts, bruises, abrasions and from minor burns—a hard hat is better than a sore head!

3. Use proper tools for the job required. Use of improper tools (such as a screwdriver instead of a pry bar, a pair of pliers instead of a wrench, a wrench instead of a hammer) not only can damage the equipment being worked on, but can lead to serious injuries. **USE THE PROPER TOOLS.**



4. Before attempting any maintenance work (including lubrication), shut off power completely. **DO NOT WORK ON RUNNING MACHINERY!**
5. When guards and covers are removed for any maintenance, be sure that such guards are reinstalled before unit is put back into operation.
6. Check all screws, bolts and nuts for proper torques before placing equipment back in service. Refer to torque chart in this manual.

7. Some parts and assemblies are quite heavy. Before attempting to unfasten any heavy part or assembly, arrange to support it by means of a hoist, by blocking or by use of an adequate arrangement to prevent it from falling, tipping, swinging or moving in any manner which may damage it or injure someone. Always use lifting device that is properly rated to lift the equipment. Do not lift loaded spreader. **NEVER LIFT EQUIPMENT OVER PEOPLE.**



8. If repairs require use of a torch or electric welder, be sure that all flammable and combustible materials are removed. Fuel or oil reservoirs must be emptied, steam cleaned and filled with water before attempting to cut or weld them. **DO NOT** weld or flame cut on any tank containing oil, gasoline or their fumes or other flammable material, or any container whose contents or previous contents are unknown.



9. Keep a fully charged fire extinguisher readily available at all times. It should be a Type ABC or a Type BC unit.
10. Cleaning solvents should be used with care. Petroleum based solvents are flammable and present a fire hazard. Don't use gasoline. All solvents must be used with adequate ventilation, as their vapors should not be inhaled.

11. When batteries are being charged or discharged, they generate hydrogen and oxygen gases. This combination of gases is highly explosive. **DO NOT SMOKE** around batteries—**STAY AWAY FROM FLAME**—don't check batteries by shorting terminals as the spark could cause an explosion. Connect and disconnect battery charger leads only when charger is "off". Be very careful with "jumper" cables.



12. Batteries contain strong sulfuric acid—handle with care. If acid gets on you, flush it off with large amounts of water. If it gets in your eyes, flush it out with plenty of water immediately and get medical help.

13. Hydraulic fluid under high pressure leaking from a pin hole are dangerous as they can penetrate the skin as though injected with a hypodermic needle. Such liquids have a poisonous effect and can cause serious wounds. To avoid hazard, relieve pressure before disconnecting hydraulic lines or performing work on system. Any fluid injected into the skin must be treated within a few hours as gangrene may result. Get medical assistance immediately if such a wound occurs. To check for such leaks, use a piece of cardboard or wood instead of your hand. Make sure all hydraulic fluid connections are tight and all hydraulic hoses and lines are in good condition before applying pressure to system. Wear protective gloves and safety glasses or goggles when working with hydraulic systems.



14. The fine spray from a small hydraulic oil leak can be highly explosive—**DO NOT SMOKE**—**STAY AWAY FROM FLAME OR SPARKS**.

1. The selection of the vehicle on which a spreader body is to be mounted has important safety aspects. To avoid overloading:
 - a. Do not mount spreader on a chassis which, when fully loaded with material to be spread, will exceed either the Gross Axle Weight Rating (GAWR) or the Gross Vehicle Weight Rating (GVWR) for the chassis.
 - b. Do install the spreader only on a vehicle with cab-to-axle dimension recommended for the spreader body length shown.



2. Follow mounting instructions in the Installation section of this manual. If mounting conditions require deviation from these instructions refer to factory.
3. When making the installation, be sure that the lighting meets Federal Motor Vehicle Safety Standard (FMVSS) No. 108, ASABE S279 and all applicable local and state regulations.
4. When selecting a PTO to drive hydraulic pump, do not use a higher percent speed drive than indicated in the Installation section of this manual. Too high a percent PTO will drive pump at excessive speed, which can ruin the pump, but more importantly, will overheat the hydraulic oil system and increase the possibility of fire.



5. When truck frame must be shortened, cut off only the portion that extends behind rear shackle in accordance with the truck manufacturer's recommendations. If a torch is used to make

the cut, all necessary precautions should be taken to prevent fire. Cuts should not be made near fuel tanks and hydraulic oil reservoirs, fuel, brake, electric or hydraulic lines and such lines should be protected from flame, sparks or molten metal. Tires should be removed if there is any chance of their being struck by flame, sparks or molten metal. Have a fire extinguisher handy.

6. Do not weld on vehicle frame as such welding can lead to fatigue cracking and must be avoided. When drilling holes in frame member, drill only through the vertical web portions do not put holes in top or bottom flanges. Refer to truck manufacturer's recommendations.

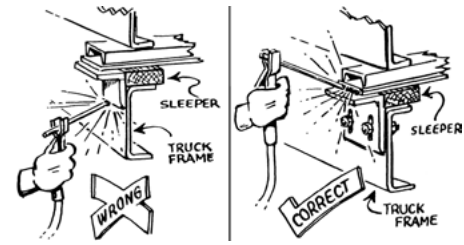

7. Be sure that welds between mounting bars and sill or between mounting angles and spreader cross sills are sound, full fillet welds. Center mounting angles so that good fillet welds can be made on three sides—an edge bead weld is not a satisfactory weld for this service. Use 309 rod/wire for carbon steel and 409 steel. On 304 stainless steel bodies use SAE grade 8 bolts—welding is recommended if type 308 welding rod is available.

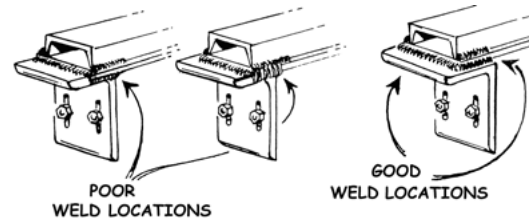

8. Install controls so that they are located of convenient use. Position them so that they do not interfere with any vehicle control and that they do not interfere with driver or passenger or with access to or exit from the vehicle.
9. Check for vehicle visibility, especially toward the rear. Reposition or add mirrors so that adequate rearward visibility is maintained.
10. Add Caution, Warning, Danger and Instruction decals as required. Peel off any label masking which has not been removed.
11. Install all guards as required.
12. Check installation completely to be sure all fasteners are secure and that nothing has been left undone.

The following instructions are to provide a guide for installing the New Leader NL200/300G4 spreader on the corresponding John Deere 4 Series sprayer chassis.

Recommended sequence of installation is:

1. Remove liquid application system per John Deere instructions.
2. Mount the spreader on the 4 Series chassis.
3. Connect all hydraulic and electrical systems.
4. Install lighting and markings (SMV sign).
5. Install Inverted "V"
6. Fill hydraulic reservoir and lubricate machine.
7. Check for leaks and ensure proper functioning.

HYDRAULIC REQUIREMENTS

Proper pump flow for the John Deere 4 Series G4 Spreader hydraulic system is 33 GPM (125 LPM).



LIFTING THE SPREADER

 **WARNING** Use only lifting devices that meet or exceed OSHA standard 1910.84 or ASME B30.20-2006. Never lift equipment over people. Never lift unit with anything or anybody in the body. Loads may shift or fall if improperly supported, causing damage to unit, injury or even death.

 **CAUTION** Use only John Deere lifting device to prevent damage to unit. Do not use lifting device to free unit from a chassis, storage stands or frozen ground, or to lift the chassis in any way. Lifting in such a manner could result in damage to unit or injury.

Always inspect unit lift points for signs of wear, cracking, corrosion, gouges, alterations, or distortion.

Position the chassis with adequate room around the unit. Work in an environment that permits clear communication to others nearby. Keep area clear of persons when loads are to be lifted and suspended. Do not allow the lifted load to come in contact with any obstruction.

Store units on a solid surface using appropriate storage stands when not installed.

Figure 1A - Attach John Deere lifting device (see John Deere for part number and instructions) to lift hooks at top corners inside spreader hopper.

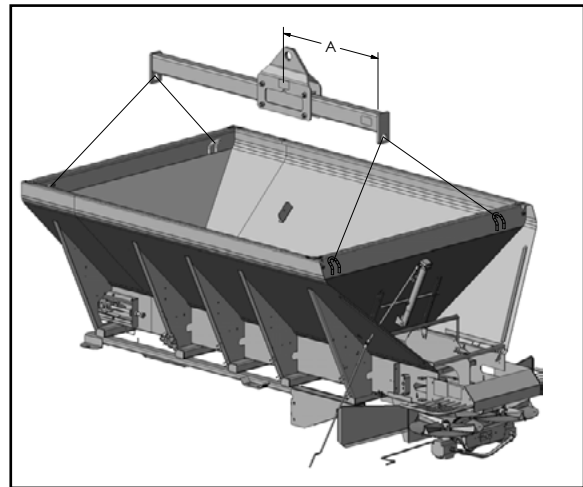

Figure 1A - Lifting Bar

Spreader Configuration	Dimension "A"
Single Bin	36" (91cm)
With MULTAPPLIER	40" (102cm)

Figure 1B - For John Deere models R4030 and R4038, install John Deere supplied spacer plates to subframe mounts prior to mounting unit to chassis.

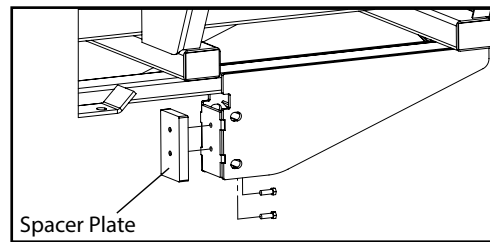

Figure 1B - Spacer Plates

INSTALLATION

SECURING SPREADER TO CHASSIS

NOTE: Mounting kit supplied by John Deere.

Figure 2 - Position the spreader with the subframe mounts directly over the chassis mounts of the vehicle.

- A: Bolt
- B: Washer
- C: Rubber Isolator
- D: Nut

Figures 3 - 5 - Starting at the rear of the chassis, install mounting hardware and hand tighten in all locations. Torque hardware as specified in the following order:

1. Rear Mounting Hardware: 315 ft-lb (425 N-m)
2. Middle Mounting Hardware: 315 ft-lb (425 N-m)
3. Front Mounting Hardware: 315 ft-lb (425 N-m)

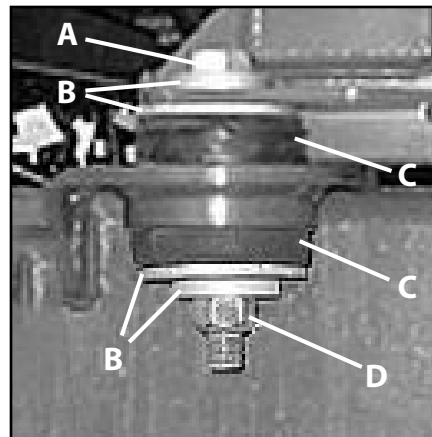

Figure 2



Figure 3 - Rear Mounting Hardware

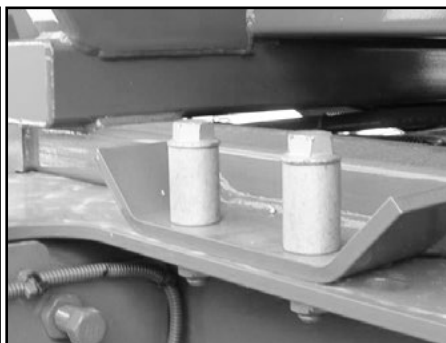

Figure 4 - Middle Mounting Hardware

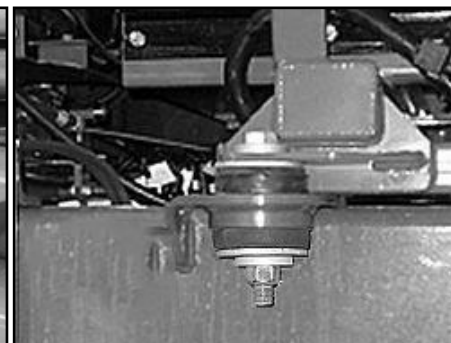

Figure 5 - Front Mounting Hardware

HYDRAULICS

Figure 6 - Identify ports on hydraulic manifold.

- A: Pressure Port "M"
- B: Return Port "MT"
- C: Load Sense Port "BLS"

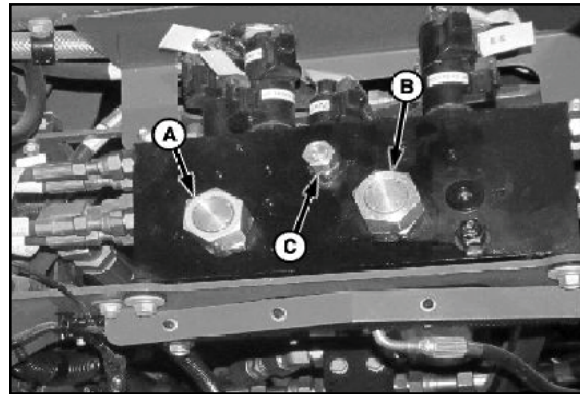

Figure 6

Figure 7 - Connect hydraulic hoses to ports. Install pressure line (D) to "M" port. Install return line (E) to "MT" port. Install load sense line (F) to "BLS" port. Tighten all connections to specification.

Figure 7 - Connect hydraulic hoses to ports.

- D: Pressure line to "M" port
- E: Return line to "MT" port
- F: Load sense line to "BLS" port

Tighten all hydraulic connections to specification.

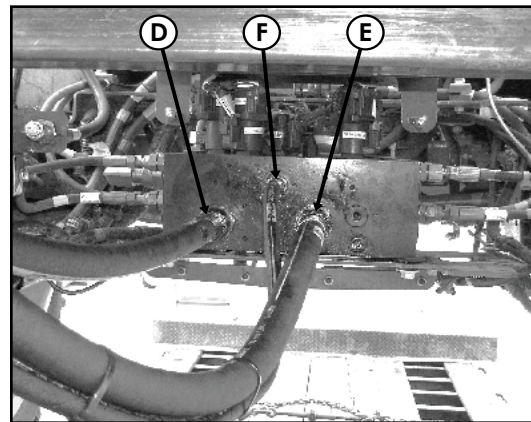

Figure 7

NOTICE!

Do NOT tighten hydraulic fittings past specified torque. If over tightened, fittings may distort, causing unstoppable leaks.

Assemble hydraulic system referencing "Body Hydraulics" parts lists. Refer to "Hydraulic Hose Installation Guide" on next page for proper hydraulic hose routing.

FILLING HYDRAULIC SYSTEM**NOTICE!**

DO NOT attempt to run pump without first filling hydraulic reservoir and opening suction line valve, or damage to pump may occur.

Fill reservoir with hydraulic oil as specified in the "Lubrication and Maintenance" section in the operator's manual. Be sure oil is clean, free from dirt, water and other contaminants.

Lubricate all points necessary per Lubrication Chart in "Lubrication and Maintenance" section of operator's manual.

HYDRAULIC HOSE INSTALLATION GUIDE

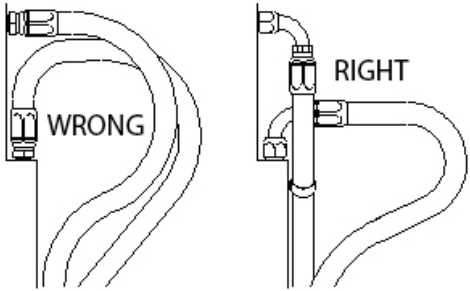
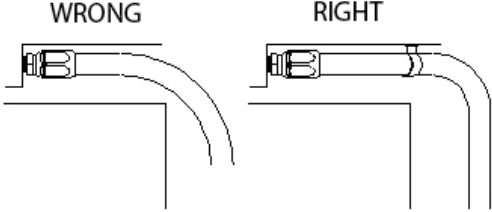
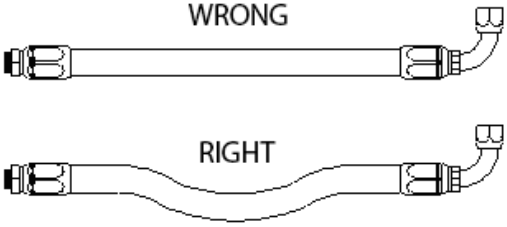
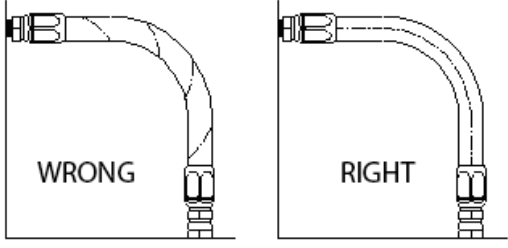
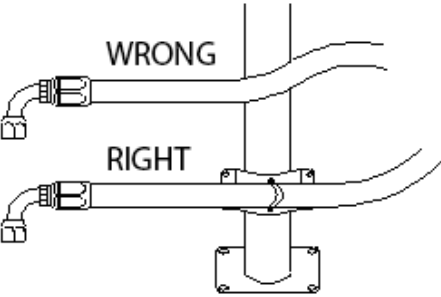
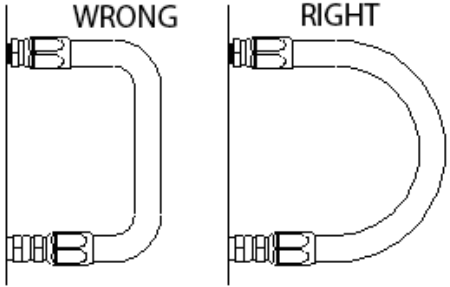
	
<p>1. Use elbows and adapters in the installation to relieve strain on the assembly, and to provide easier and neater installations that are accessible for inspection and maintenance. Remember that metal end fittings cannot be considered as part of the flexible portion of the assembly.</p>	<p>2. Install hose runs to avoid rubbing or abrasion. Clamps are often needed to support long runs of hose or to keep hose away from moving parts. It is important that the clamps be of the correct size. A clamp that is too large will allow the hose to move in the clamp causing abrasion at this point.</p>
	
<p>3. In straight hose installations allow enough slack in the hose line to provide for changes in length that will occur when pressure is applied. This change in length can be from +2% to -4%.</p>	<p>4. Do not twist hose during installation. This can be determined by the printed layline on the hose. Pressure applied to a twisted hose can cause hose failure or loosening of the connections.</p>
	
<p>5. Keep hose away from hot parts. High ambient temperature will shorten hose life. If you cannot route it away from the heat source, insulate it.</p>	<p>6. Keep the bend radii of the hose as large as possible to avoid hose collapsing and restriction of flow. Follow catalog specs on minimum bend radii.</p>

(Used with the permission of The Weatherhead Company.)

ELECTRICAL CONNECTIONS

Figure 8 - Locate electrical harness on unit. Disconnect CAN harness (E) and remove tie band (D).

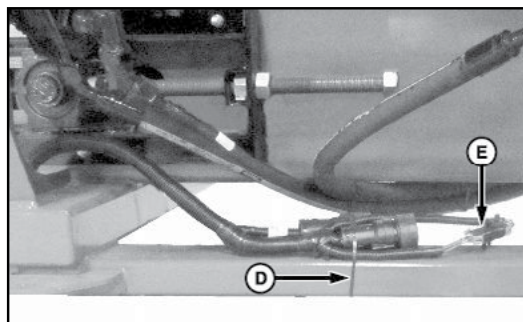

Figure 8

Figure 9 - Locate chassis connection points (A, B, & D)

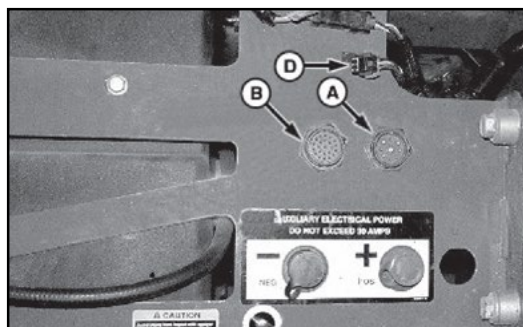

Figure 9

Figure 10 - Connections

- Connect 9-pin (A) and 23-pin (B) connectors to machine.
- Connect CAN harness (C) to machine harness (D).
- Install CAN terminator (E) to spreader CAN harness (F).
- Retain CAN terminator as shown, as well as any other loose portions of harness to prevent damage.

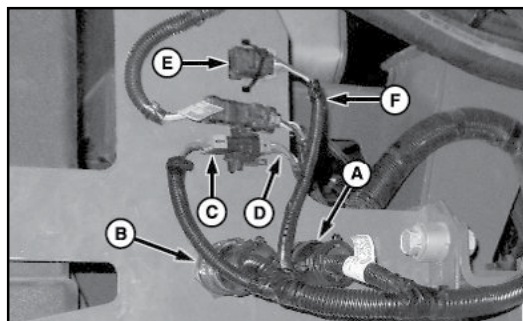

Figure 10

LIGHT INSTALLATION**TAIL LIGHTS**

Figure 11 - Tail lights and brackets are factory installed in upward position for shipping. Loosen hardware and adjust both brackets downward so that they are parallel with ground. Re-tighten hardware to specified torque.



Figure 11A - Shipping Position

Figure 11B - Operating Position

BEACON KIT (OPTIONAL)

Figure 12 - Loosen hardware from right hand tail light bracket. Support bracket and remove hardware. Attach beacon bracket over tail light bracket with existing hardware and torque to spec.



Figure 12

Figure 13 - Attach electrical harness to end of bracket:

1. Thread loose wire through bottom of hole on end of bracket.
2. Connect loose wire to beacon connector and secure. Thread connector into top of hole on end of bracket.

Figure 14 - Attach beacon to bracket and tighten wing nut.

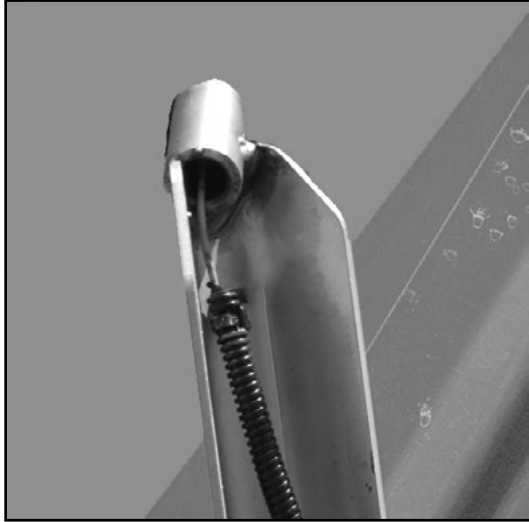

Figure 13

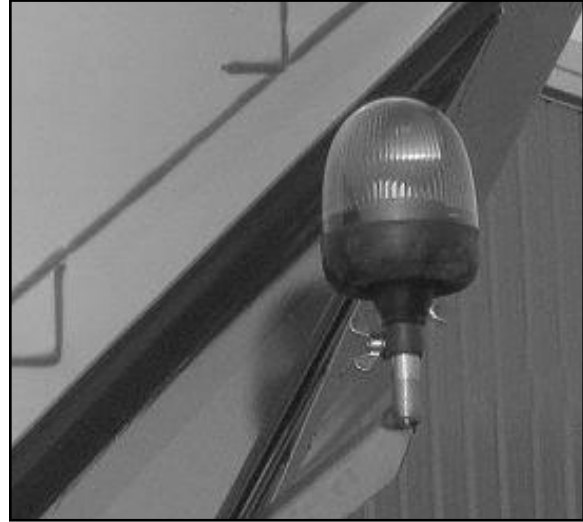

Figure 14

Figure 15 - Route beacon harness down bracket and secure. Connect to main light harness.

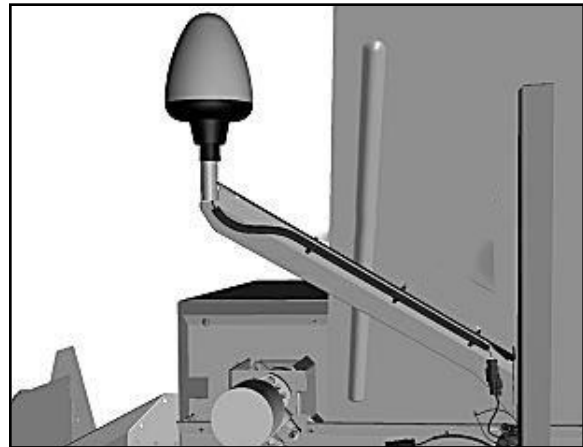
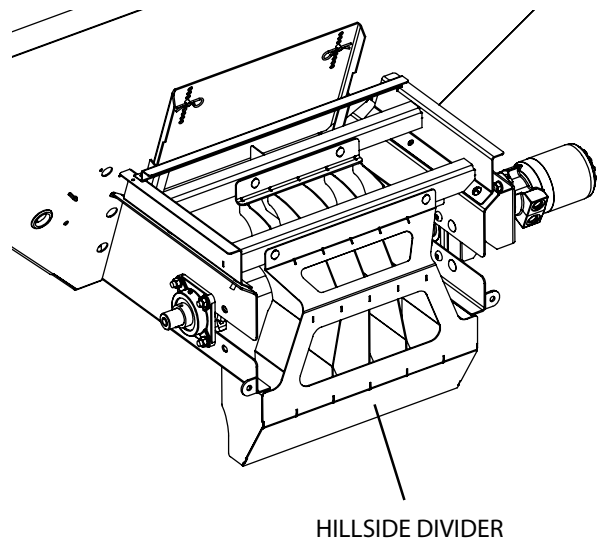
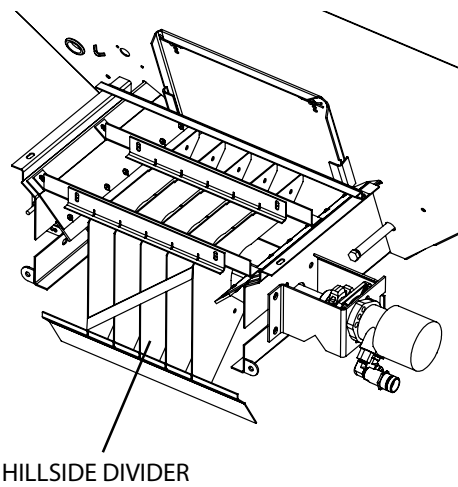
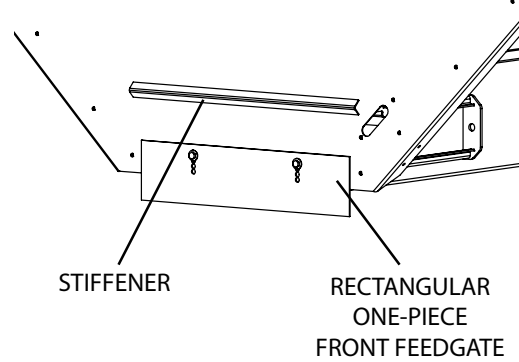
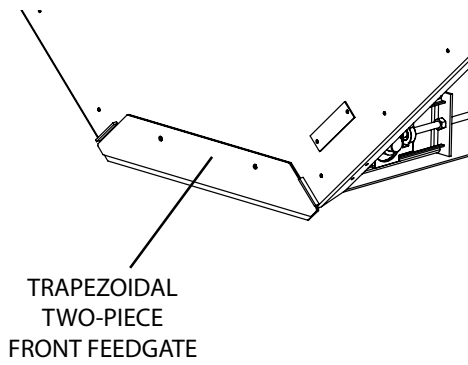
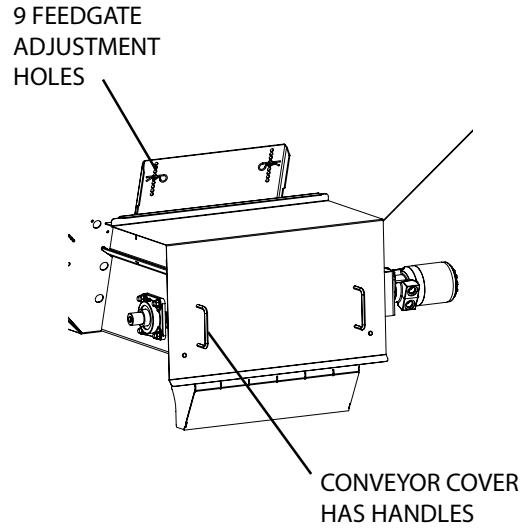
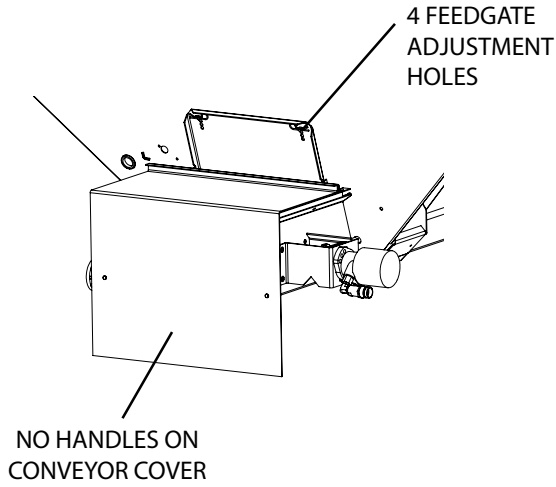

Figure 15

Style I

Style II



Recommended sequence of installation is:

1. Spreader preparation.
2. Insert preparation.
3. Mounting of insert.
4. Connecting hydraulic hoses.
5. Installation of hillside divider and conveyor cover.
6. Checking installation.
7. Checking for leaks and proper functioning.

SPREADER PREPARATION



WARNING

Use only lifting devices that meet or exceed OSHA standard 1910.184. Never exceed work load limits or lift equipment over people. Empty spreader before lifting. Loads may shift or fall if improperly supported, causing injury.

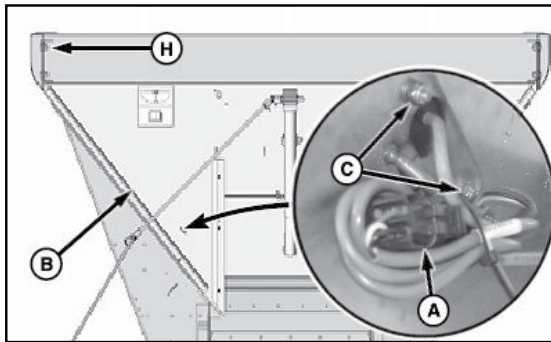

Figure 1

Figure 1 - Disconnect bin level sensor (A) from main harness (B).

Remove endgate mounting hardware (H).

Figure 3 - Remove hair pin (F) and Feedgate Jack Handle (G).

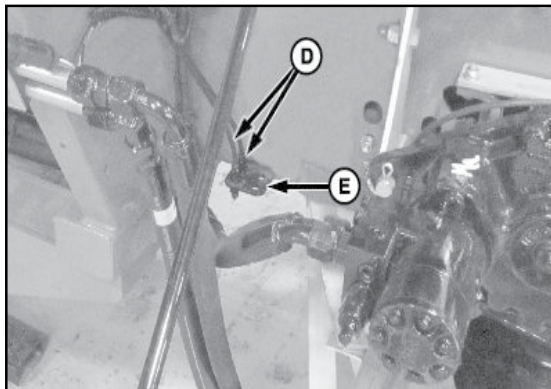

Figure 2

Figure 2 - Disconnect Feedgate grease lines (D) from bracket (E).

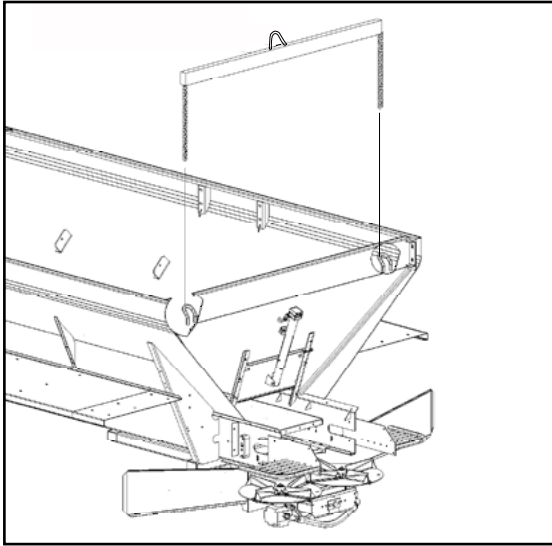

Figure 3

Remove the Inverted “V” and Hillside Divider from the spreader, if so equipped, and set hardware aside.

Support endgate by attaching a hoist to the lift hooks. Carefully remove from the spreader as shown in Figure 3.

NOTE: Always use a sling, spreader bar, or lifting bar that attaches to the lifting points with a minimum of 60 degrees from horizontal. It is preferable to use a straight style lifting bar that keeps the attaching chains in a near vertical orientation.

NOTE: Always inspect unit lift hooks for signs of wear, cracking, corrosion, gouges, alterations, or distortion before use.

FEEDGATE ADJUSTMENT**WARNING**

Stay out of the spreader. If it's necessary to enter the spreader, return to the shop, empty body, turn off all power, set vehicle brakes, lock engine starting switch and remove keys before entering. Tag all controls to prohibit operation. Tags should be placed, and later removed, only by person working in the body.

Adjust the insert's front feedgate prior to installation.

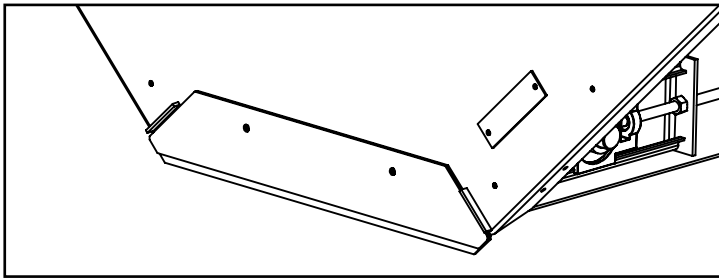

**Figure 4A - 1 1/2" (3.81 cm) or 2" (5.08 cm) Opening
(Style I MULTAPPLIER, #5 Straight Belt in Main Bin)**

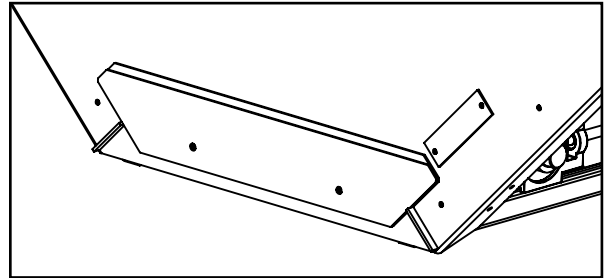

**Figure 4B - 3" (7.62 cm) Opening
(Style I MULTAPPLIER, #5 Straight Belt in Main Bin)**

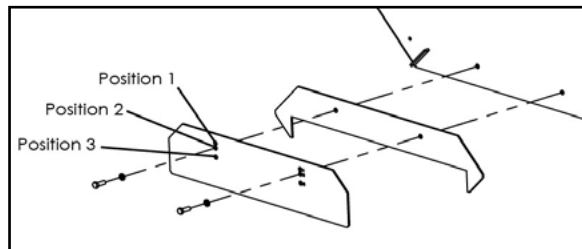
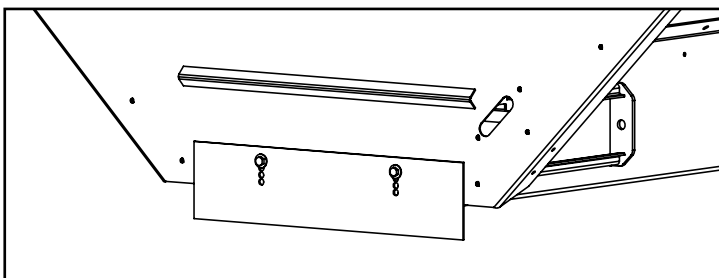
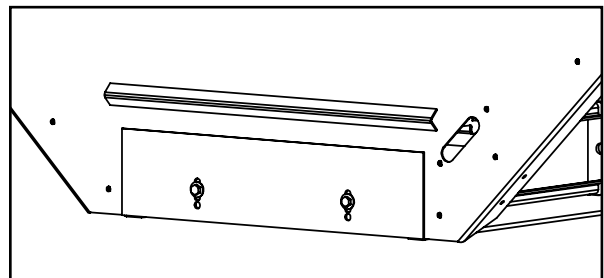

Figure 4C - Feedgate Adjustment (Style I MULTAPPLIER, #4 BOC in Main Bin)

Style I MULTAPPLIER - To adjust main bin's feedgate opening on a Style I MULTAPPLIER-equipped unit: position front feedgates on MULTAPPLIER as necessary to achieve a 1-1/2 inch (3.81 cm), 2 inch (5.08 cm) or 3 inch (7.62 cm) opening. Position both feedgates with short side down for a 3" (7.62 cm) opening. NOTE: Both feedgates are installed for shipping.



**Figure 5A - 2 1/2" (3.81 cm) or 2" (5.08 cm) Opening
(Style II MULTAPPLIER)**



**Figure 5B - 4" (10.16 cm) Opening
(Style II MULTAPPLIER)**

Style II MULTAPPLIER - To adjust main bin's feedgate opening on a Style II MULTAPPLIER-equipped unit: position front feedgate on MULTAPPLIER as necessary to achieve a 1 1/2 inch (3.81 cm) to 4 inch (10.16 cm) opening in 1/2 inch increments.

1. Make sure rubber sealer hardware is loose. If not, loosen.



Figure 6A

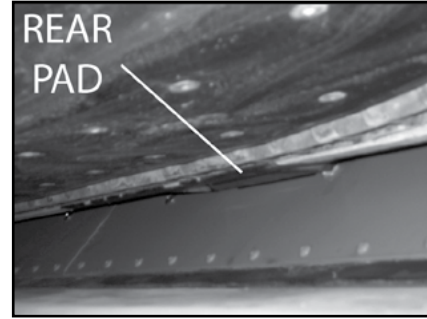

Figure 6B

2. To install MULTAPPLIER:
 - a. Figure 6A - Hoist and slide MULTAPPLIER into position between main bin's side sheets.
 - b. Figure 6B - Align MULTAPPLIER's and main bin's front and rear mount brackets.
 - c. Make sure MULTAPPLIER is resting on inside of main bin, and not resting on tops of side sheets.
 - d. Release tension on hoist but do not remove.



Figure 7A (uninstalled)

Figure 7B (shown installed)
View from rear of unit.

3. Figures 7A-7B - Visually make sure insert is centered from side to side in main bin and rear pads are resting on main bin.

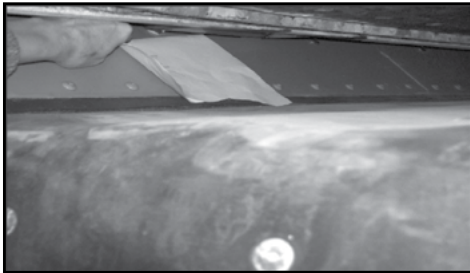

Figure 8



Figure 9

4. Figure 8 - There must be contact between rear pads and main unit. Check for contact by trying to slide paper between pads and main bin. If no contact, adjust insert.
5. Figure 9 - Inside main unit, locate front pads by lifting rubber sealers on front endgate.

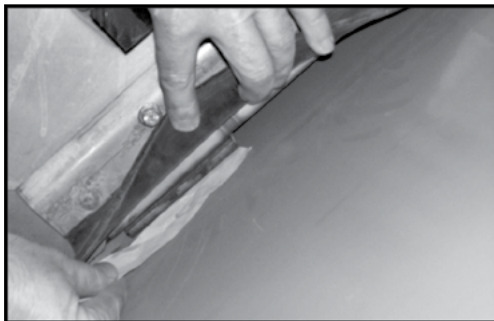

Figure 10A

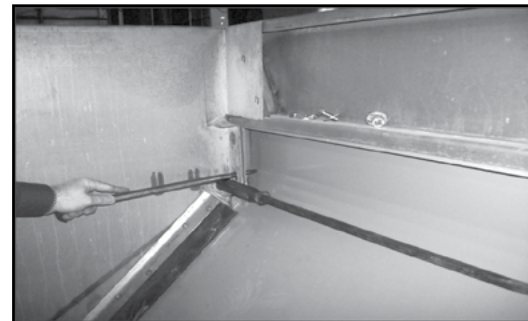

Figure 10B

6. Figures 10A-10B - There must be contact between front pads and main bin. Check for contact by trying to slide paper between pads and main bin. If no contact, adjust insert.
NOTE: Pry insert at mount brackets if necessary.



Figure 11



Figure 12



Figure 13

7. Figure 11 - Once both front pads make contact, insert hardware in front mount brackets' lower holes. Shim between main bin and insert brackets if distance is larger than 1/8" (.32cm). Tighten hardware per torque recommendations in this manual.
8. Figure 12 - Make sure front feedgate is level. Lower endgate sealers so flush with chain shields and tighten hardware.

NOTICE!

Leakage of material may occur if the sealer belts are not set properly on the front of the insert. Highway Equipment Company is not liable for lost material due to improperly installed sealer belts.

9. Figure 13 - Make sure there is a complete seal covering the gap between the insert and the main bin's side sheets. Tighten all hardware on rubber sealers at front of insert.
10. Make sure rear pads are still in place against main bin. Install hardware in lower holes of rear mount brackets. Shim between main bin and insert brackets if distance is larger than 1/8" (.32cm). Tighten hardware per torque recommendations in this manual.
11. Make sure insert's side sheets are not resting on top of main bin's side sheets.
12. Install hardware in all four mount brackets' upper holes. Tighten hardware per torque recommendations.
13. Remove hoist.
14. Inspect unit for foreign debris in conveyor area.

HYDRAULICS

Attach insert hoses to spreader hoses as shown in Figure 12. Plug in rate sensor.

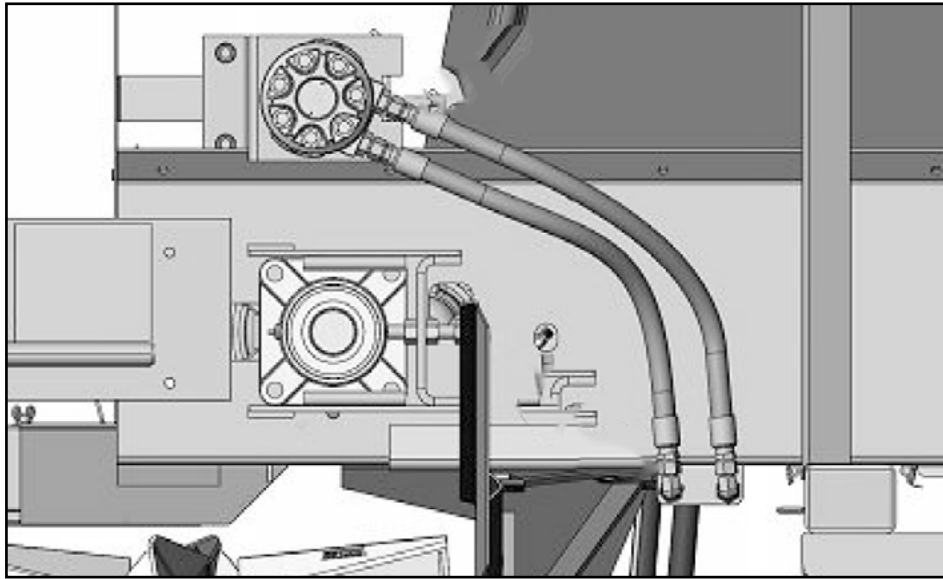

Figure 14 - MULTAPPLIER Operation

ELECTRICAL CONNECTIONS

Connect all electrical control circuits. The supply conductor should be connected directly to the battery. All wiring should be approved automotive insulated wire, supported adequately with insulating ties or straps, and located where it will not interfere with any control or access. Make sure wiring does not contact any moving parts or sharp edges and is kept away from hydraulic lines and heated parts.

HILLSIDE DIVIDER & CONVEYOR COVER

NOTICE!

Highway Equipment Company will not be liable for misapplied material due to an improperly adjusted divider, spreader or both.

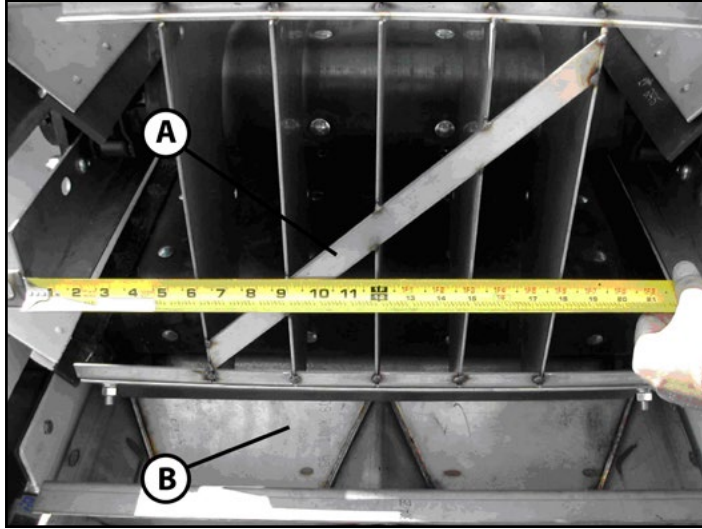

Figure 19A - MULTAPPLIER Hillside Divider (Style I)

Style I MULTAPPLIER - Remove hardware from rear two chain shield holes on each side of MULTAPPLIER and set aside. Install MULTAPPLIER Hillside Divider (A) over conveyors and attach using chain shield hardware. Adjust Hillside Divider so that the middle divider is centered over both conveyors and the Material Divider (B) as shown in Figure 19A. Tighten hardware to recommended torque.

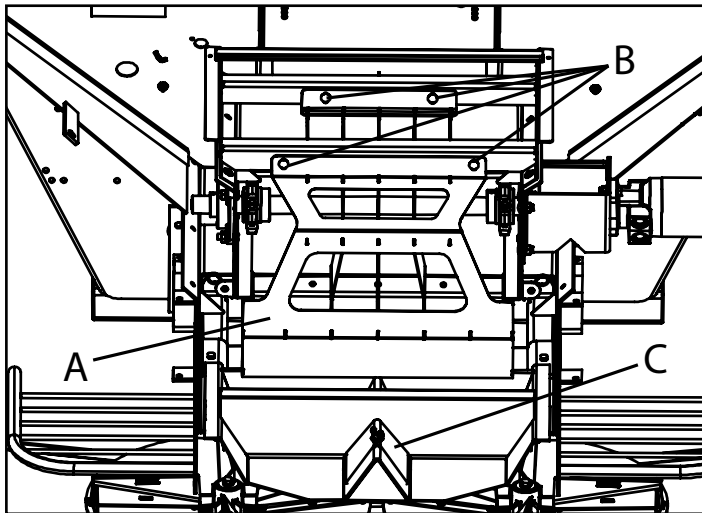

Figure 19B - MULTAPPLIER Hillside Divider (Style II)

Style II MULTAPPLIER - Loosen hardware from rear two chain shield holes on each side of MULTAPPLIER. Install MULTAPPLIER Hillside Divider (A) and fasten to Support using single bin Hillside Divider hardware removed before MULTAPPLIER installation (B). Adjust Hillside Divider so that the middle divider is centered over both conveyors and the Material Divider (C) as shown in Figure 19B. Tighten all hardware to recommended torque.

INSTALLATION

INSERT REMOVAL/ENDGATE INSTALLATION

Remove insert and reinstall endgate, Inverted "V", single conveyor Hillside Divider, etc. by following applicable installation instructions in reverse order. Make sure the insert hydraulics, electrical connections and air lines are disconnected from the spreader before removal. See "Inverted V" in spreader parts manual.

Hydraulics Removal

Route hydraulic hoses on the spreader and the insert as shown in Figure 16.

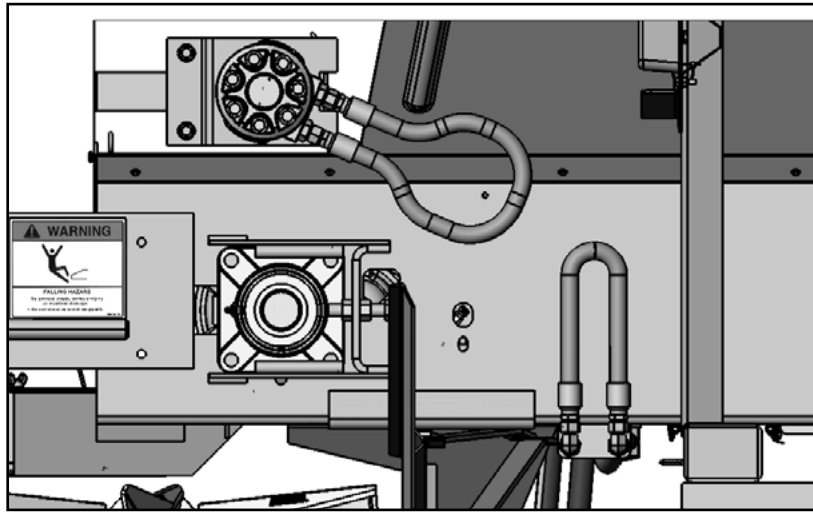

Figure 16 - Detach MULTAPPLIER

The John Deere 4 Series NL200G4 and NL300G4 are hopper type spreaders intended for spreading free flowing granular agricultural materials, such as chemical fertilizers. When installed on the R4045 chassis, the NL200G4 can be used to apply agricultural limestone. The NL200G4 is NOT intended to spread agricultural limestone when installed on the R4030 or R4038. The MULTAPPLIER allows you to spread two different materials individually or combined. The spreaders are intended for high-clearance post-emergence vehicles—the John Deere 4 Series.

The units are powered hydraulically and provide independent variable speed control for the spinners and full automatic ground speed control for the conveyor.

The conveyor(s) deliver material to the spinners through an adjustable metering gate at the rear of the hopper body. An orbital type hydraulic motor mounted to a 6-to-1 ratio spur gear case drives the main bin conveyor, and a direct drive motor drives the the MULTAPPLIER conveyor. The NL200G4 has the choice of a #5 straight belt conveyor, or a #4 belt-over-chain conveyor, consisting of parallel strands of pintle chain joined by cross bars at every other link. The NL300G4 has a #5 straight belt conveyor. The MULTAPPLIER has a stainless steel #4 belt-over-chain conveyor.

The MULTAPPLIER is currently available in two different styles; Style I and Style II. The Style II MULTAPPLIER provides higher output capabilities. Refer to *MULTAPPLIER Style Comparison* in this manual to determine your style of MULTAPPLIER.

The distributor spinner assembly has two 24 inch (60.96cm) diameter dished discs. Each disc has four formed and heat treated fins that are adjustable to radial angle. The spinner is fully adjustable by means of a rotating handle.

These products are intended for commercial use only.

The application of free flowing granular agricultural materials must be done according to the manufacturers' instruction and legal user regulations. Intended use also implies the observance of all user and maintenance instructions prescribed by the manufacturer. Any other use is regarded as noncompliant with its purpose including:

- improper use of agrochemicals (herbicides, fungicides, insecticides, growth regulators) and liquid fertilizers
- noncompliance with instructions issued by the manufacturers of fertilizers and crop protection chemicals
- noncompliance with legal requirements applicable to the use of fertilizers and crop protection chemicals including their combination with other chemicals

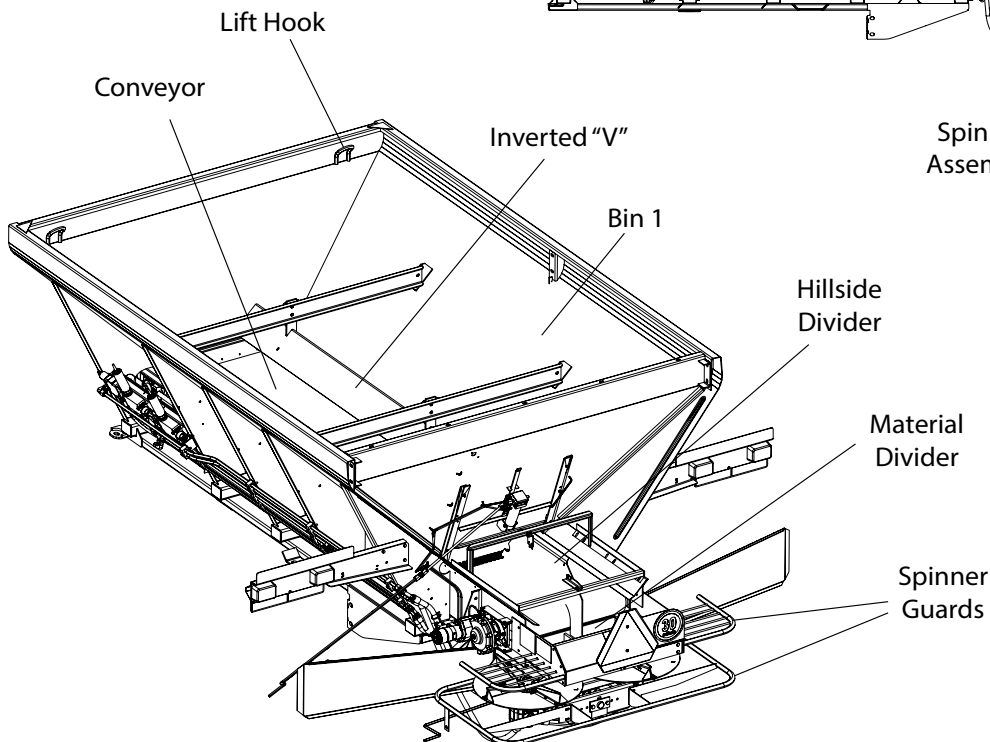
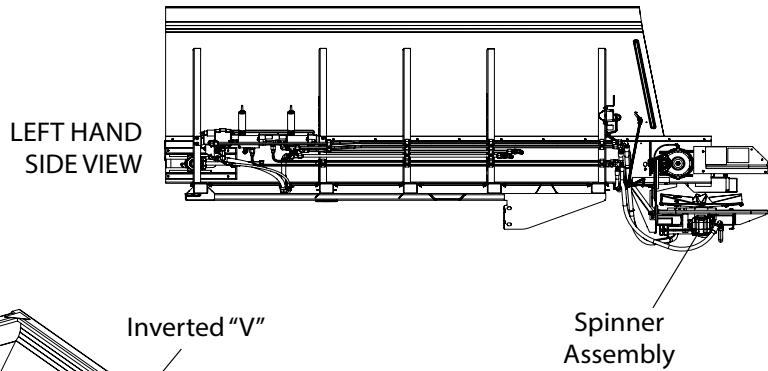
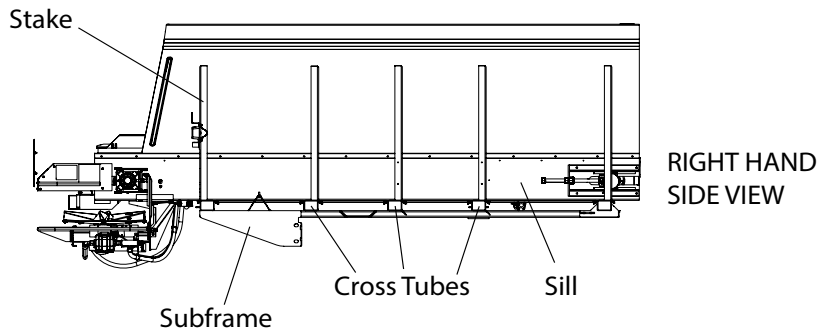
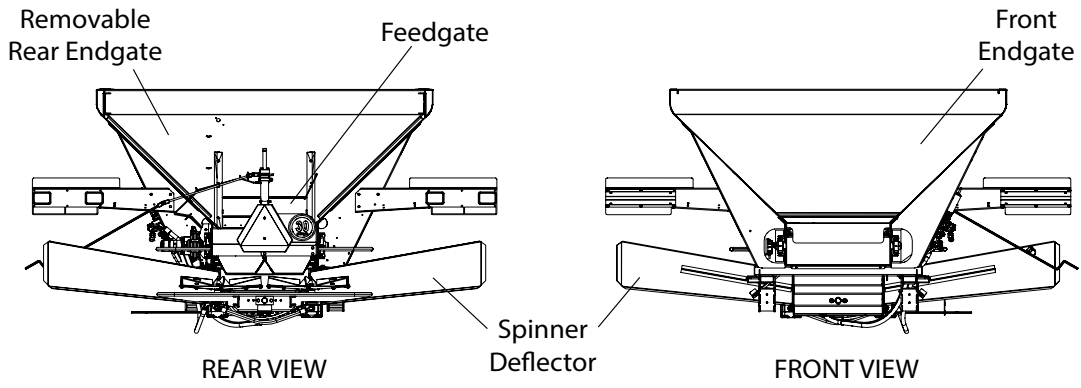

INTRODUCTION



Bin 1: Main holding bin for material or Insert. Multiplier and MultiBin inserts (shown on following pages) are configured as Bins 2-4 depending on type used.

Rear Endgate: Welded or bolt-in endgate (depending on model) furthest from chassis cab (Rear based on direction of travel). Holds mounted Feedgate, allowing for rear release of material from bin.

Feedgate: Adjustable gate mounted into Rear Endgate. Allows for variable rates of material flow by adjusting jack to desired height.

Conveyor: Conveys material to rear of unit.

Inverted "V": Mounted inside Main Hopper when Insert not installed. Distributes weight pressure across conveyor, allowing for consistent material flow to Feedgate, and promotes an improved blend when spreading fertilizer.

Material Divider: Ensures uniform spread pattern by directing material off of conveyor onto spinner discs.

Hillside Divider: Ensures balanced flow of material across conveyor when on hillsides or uneven terrain.

Sill: Base of Main Hopper side walls. Contains Conveyor and supports machine walls.

Cross Tubes: Supports body, attaches to Chassis frame. Transfers weight from Main Hopper to Chassis.

Stake: Side support for main hopper walls.

Subframe: Fully welded frame for attaching spreader to vehicle chassis.

Spinner Assembly: Contains adjustable G4 Spreader system, consisting of hydraulic spinners used for dispersal of various materials at different positioned settings allowing for consistent, even spread patterns across a wide variety of material with a high rate of accuracy.

Spinner Guards: Upper and Lower guards, protects operators from spinner discs. Must be in place during any operation.

Spinner Deflectors: Deflect material away from machine.

Lift Hooks: Used to lift unit or insert with appropriately rated lifting device.

MULTAPPLIERS

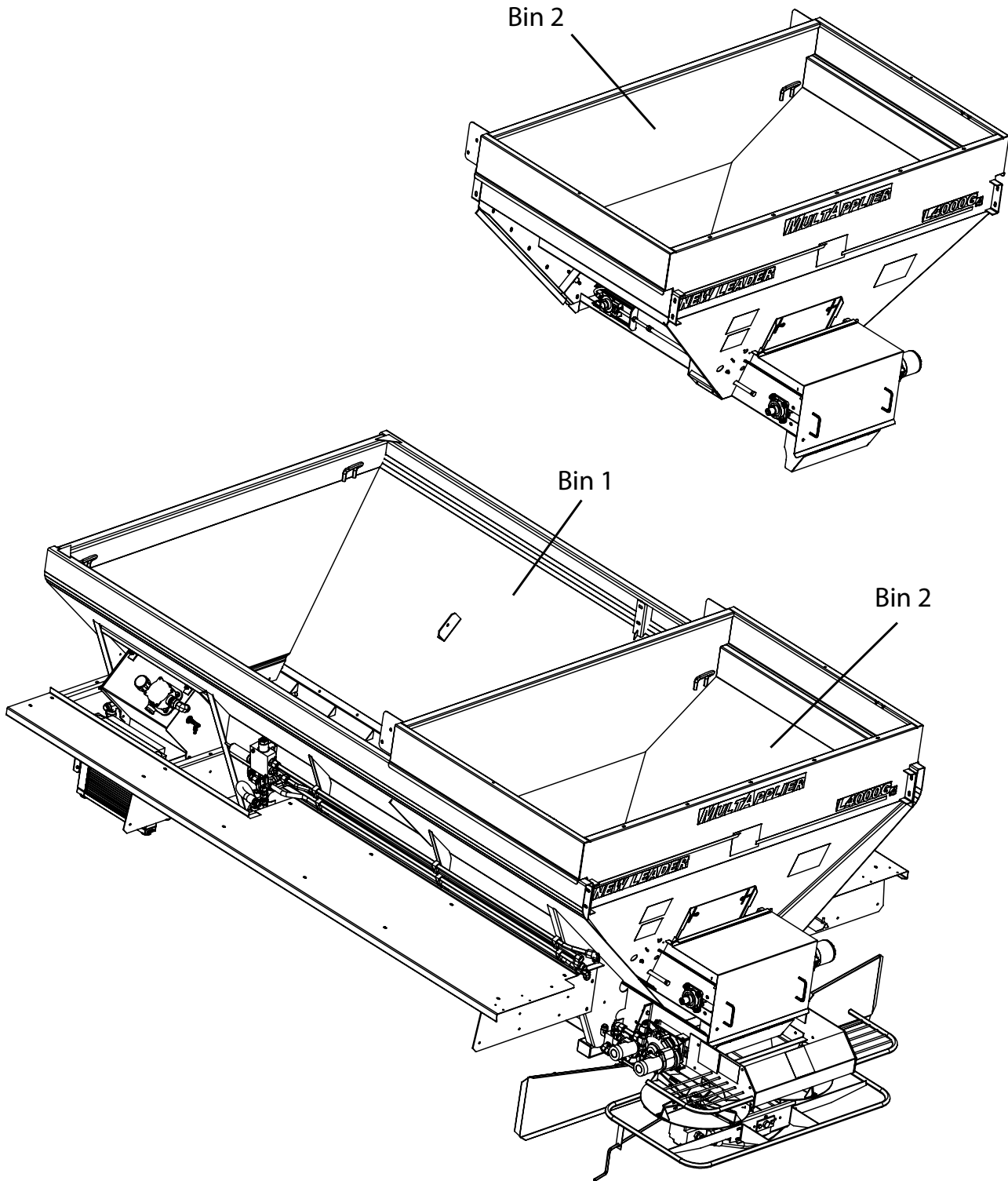

INTRODUCTION

This page is intentionally left blank.

NL200/300G4, SINGLE BIN

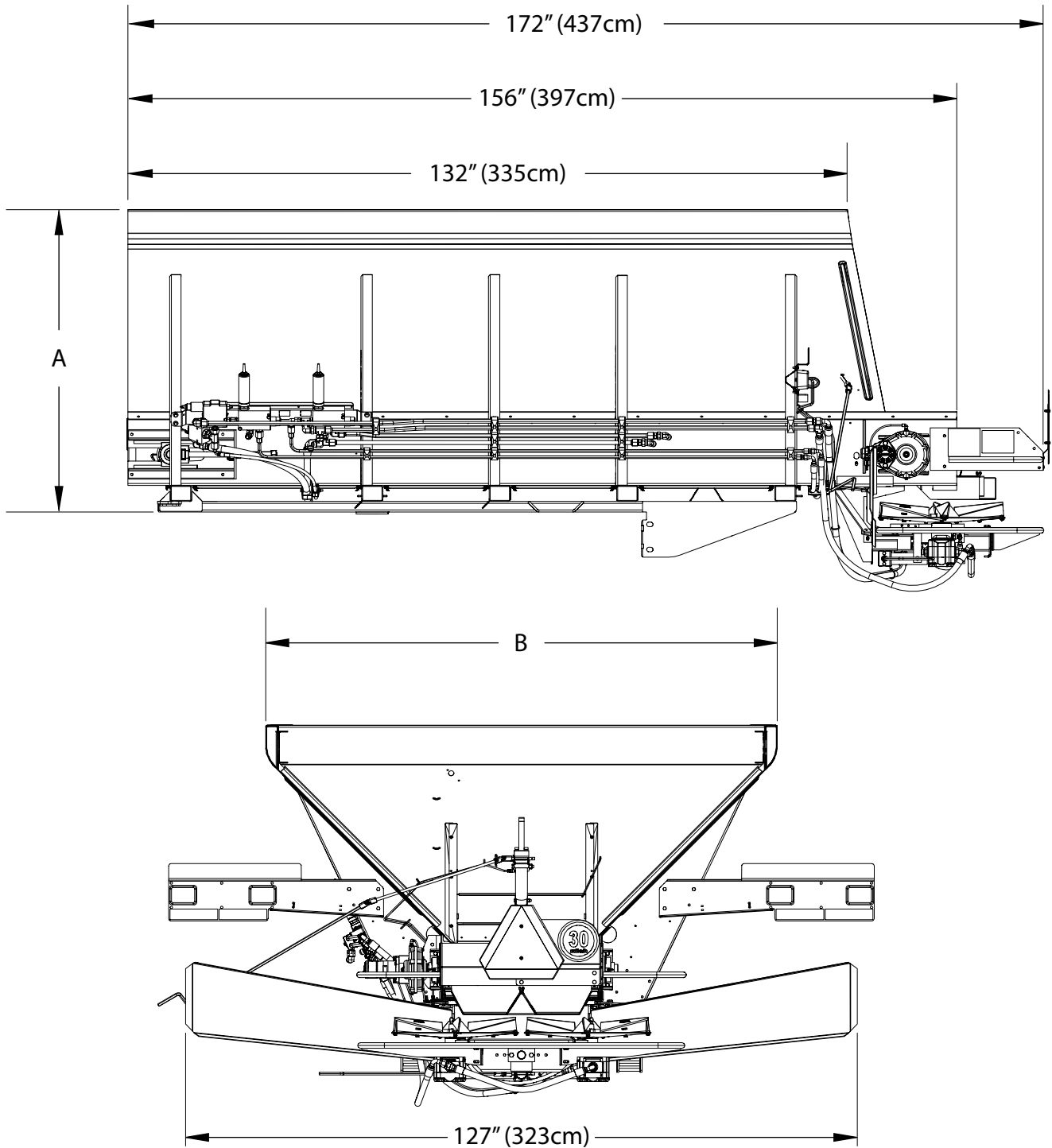

DIMENSIONS & CAPACITIES

NL200/300G4, SINGLE BIN WEIGHTS & CAPACITIES

Unit Type	Overall Height A	Top Width B	Approximate Weight Lbs (Kg)	Struck Capacity Cu Yd (Cu M) Cu Ft
NL200G4 w/ #5 Belt	57" (145cm)	96" (244cm)	3240 (1470)	7.41 (5.66) 200
NL200G4 w/ #4 BOC			3640 (1651)	
NL300G4 w/ #5 Belt	69" (175cm)	120" (305cm)	3740 (1696)	11.1 (8.50) 300

NL200/300G4 WITH MULTAPPLIER

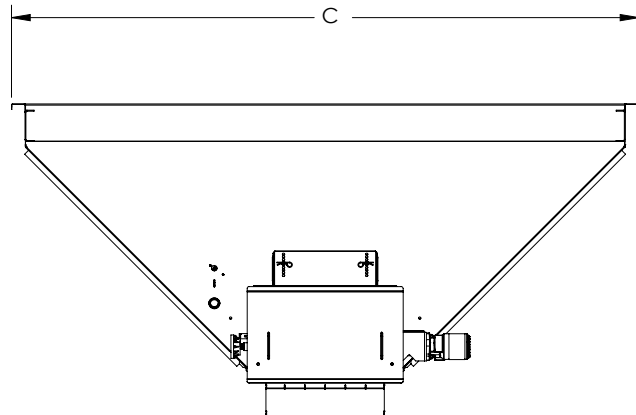
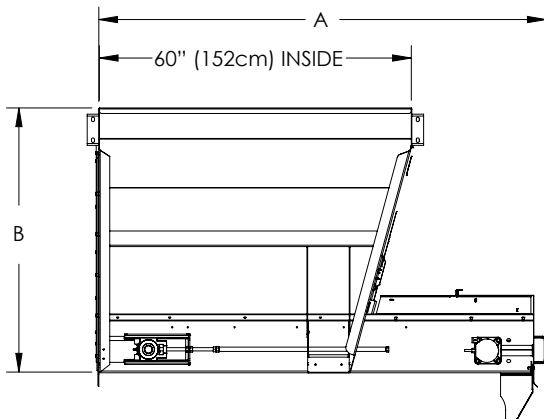
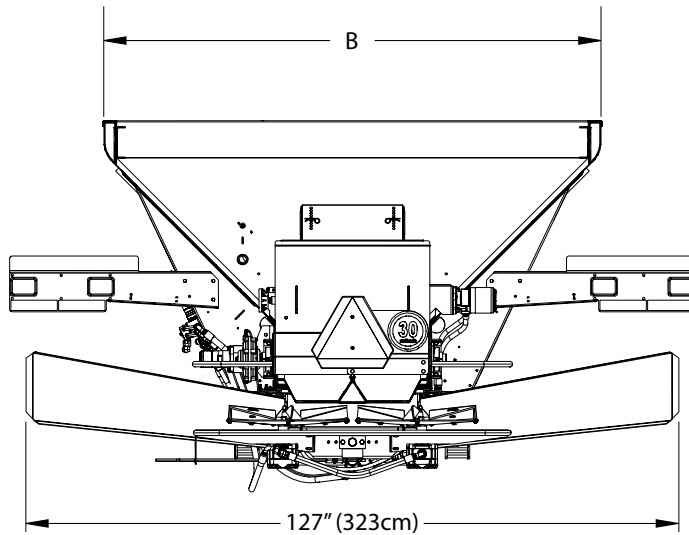
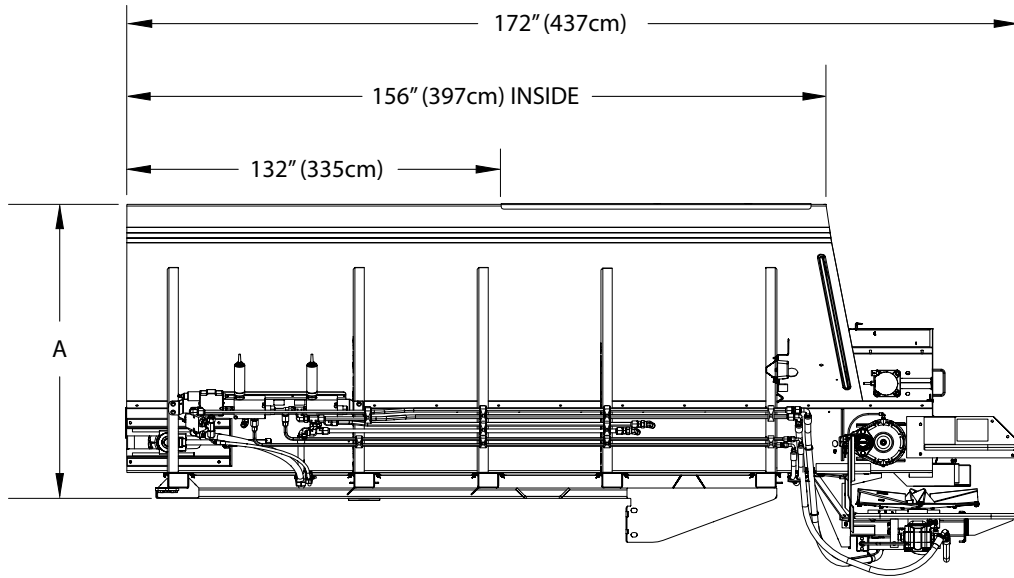

DIMENSIONS & CAPACITIES

NL200/300G4 WITH MULTAPPLIER WEIGHTS & CAPACITIES

	With Multiplier	
Unit Type	Approximate Weight Lbs (Kg)	Struck Capacity Cu Yd (Cu M) Cu Ft
NL200 w/ #5 Belt	3840 (1742)	3.93 (3.00) 106
NL200 w/ #4 BOC	4240 (1923)	
NL300 w/ #5 Belt	4445 (2016)	6.00 (4.59) 162

STYLE I MULTAPPLIER ALONE DIMENSIONS & CAPACITIES

Insert Unit Length	Overall Length A	Height B	Approximate Weight Lbs (Kg)	Struck Capacity Cu Yd (Cu M) Cu Ft
NL200G4	84" (213cm)	39" (99cm)	950 (431)	2.44 (1.87) 66
NL300G4		51" (130cm)	1120 (508)	3.93 (3.00) 106

STYLE II MULTAPPLIER ALONE DIMENSIONS & CAPACITIES

Insert Unit Length	Overall Length A	Overall Height B	Top Width C	Approximate Weight Lbs (Kg)	Struck Capacity Cu Yd (Cu M) Cu Ft
NL200G4	86" (218cm)	39" (99cm)	97" (246cm)	950 (431)	2.44 (1.87) 66
NL300G4		51" (130cm)	121" (301cm)	1120 (508)	3.93 (3.00) 106



WARNING Stand clear of moving machinery.

NOTE: Do not load spreader with material.

1. Check entire unit to make sure all fasteners are in place and properly tightened per “Standard Torques” in this manual.
2. Make sure no other persons are in vicinity of spreader.
3. Make sure no loose parts are in unit or on conveyor or spinner.
4. Check oil level in hydraulic reservoir; fill as necessary. Refer to “Lubricant & Hydraulic Oil Specifications” in this manual for proper oil. Completely open reservoir valves.
5. Start engine and turn on hydraulics. Run hydraulic system to bring oil up to operating temperature.
6. Run spinner only at 300RPM. Allow to run until spinner is operating smoothly and all air has been purged from system.
7. Run conveyor at 20RPM and spinner at 300RPM. Run until conveyor is operating smoothly.
8. Run conveyor at 20RPM and spinner at 700RPM. Allow both conveyor and spinner to run until operating smoothly.
9. Run conveyor at 0RPM and spinner at 0RPM. Make sure both conveyor and spinner do not move.
10. Calibrate spreader as defined in the manual for the controller that is supplied with your machine.
11. Complete spread pattern test per “Spread Pattern Testing” in this manual.
12. Shut system down.



WARNING

DO NOT check leaks with hands while system is operating as high pressure oil leaks can be dangerous! If skin is pierced with hydraulic fluid at high pressure seek immediate medical attention as fluid injected into the skin could cause gangrene if left untreated. Relieve pressure before disconnecting hydraulic lines or working system. Make sure all hydraulic fluid connections are tight and all hydraulic hoses and lines are in good condition before applying pressure to the system. Wear protective gloves and safety glasses or goggles when working with hydraulic systems.



WARNING

DO NOT check for leaks adjacent to moving parts while system is operating as there may be danger of entanglement!

13. Check all connections in hydraulic system to make sure there are no leaks.
14. Check hydraulic oil reservoir and refill to maintain level at mid-point of gauge.

G4 SPINNER SQUARINGClick or Scan -
Single Bin UnitClick or Scan -
MultiBin Unit

The squareness of the G4 Spinner Assembly and supporting parts plays a critical role in obtaining acceptable spread patterns. It is highly recommended that measurements are checked before spreading with a new unit, and any time after service or repair work has been performed on any part affecting spread patterns.

1. Figure 1 - Begin by ensuring that the Spinner Assembly is mounted correctly. The Spinner Frame should be sitting on top of/inside the Sill flanges, NOT hanging below.

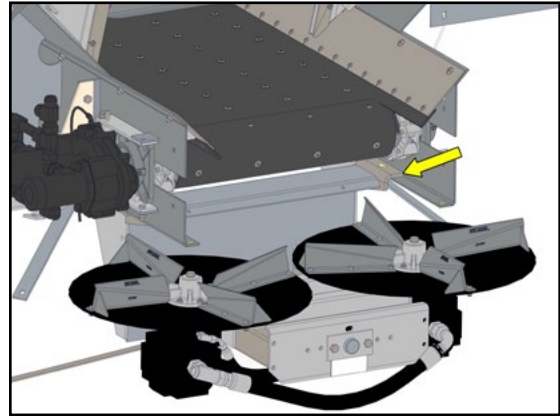

Figure 1

2. Figure 2 - Measure from the Spinner Frame mounting flange to the end of the Sill on each side. Measurement should be 9-7/8" (25cm). Measurements must be equal, or no greater than 1/8" (0.3cm) off overall.

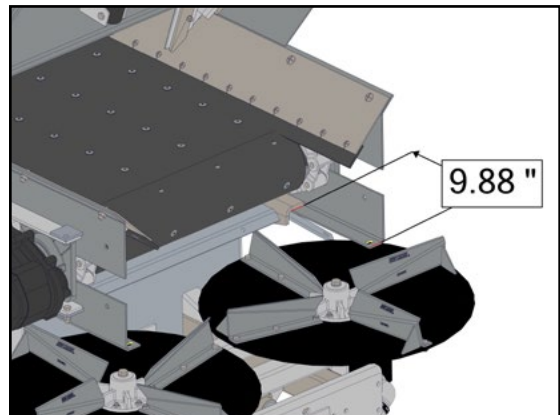

Figure 2

3. Figure 3A - 3B - Check Spinner Assembly squareness by measuring from top edge of left hand Sill to inner hex flat on right hand Spinner Hub bolt. Repeat for opposite side.

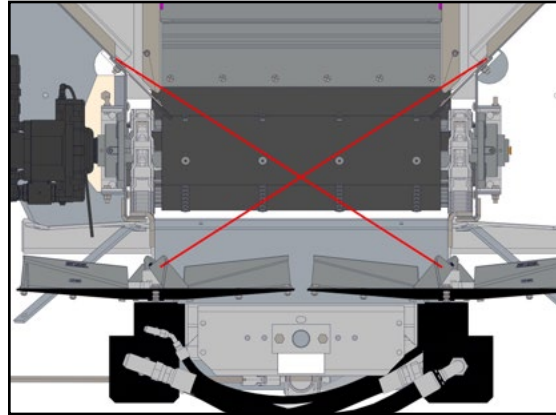

Figure 3A

4. Measurements must be equal, or no greater than 1/8" off overall.

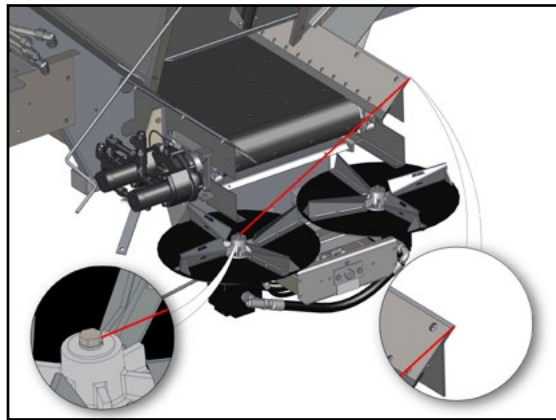

Figure 3B

5. Figure 4 - If adjustments are necessary, loosen the four 1/2" carriage bolts and adjust assembly as necessary. Once corrected, tighten hardware to recommended torque. See "Standard Torques" for details.

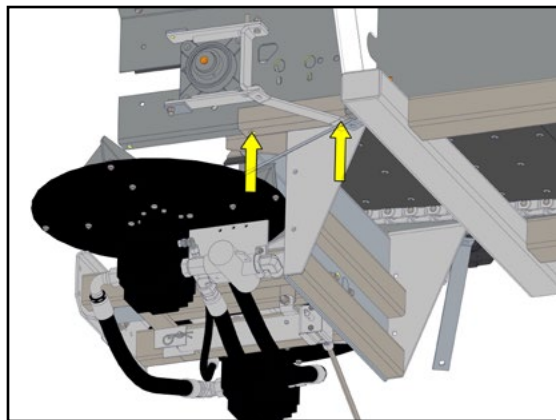

Figure 4

6. Figure 5 - Center Material Divider by measuring from the right hand inner drop-off point to the inner hex flat on the right hand Spinner Hub Bolt. Repeat measurement on opposite side. Measurements must be equal, or no greater than 1/8" off overall.

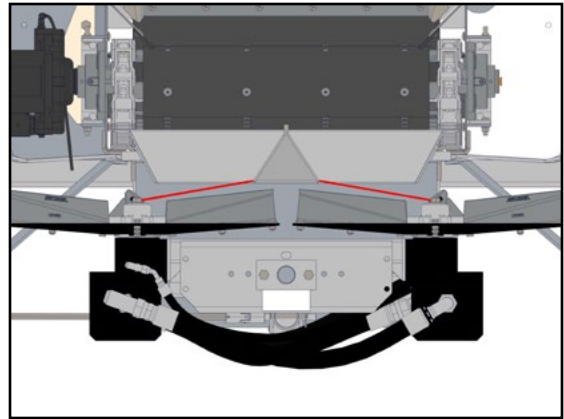

Figure 5

7. Figure 6 - Measure on each side from Spinner Frame back plate to forward drop-off point on Material Divider. Both measurements must be 12-1/4" (31cm) or no greater than 1/8" (0.3cm) off overall.
8. Figure 7 - If adjustments are necessary, loosen the 3/8" capscrews on each side and adjust as necessary. Once corrected, tighten hardware to recommended torque.

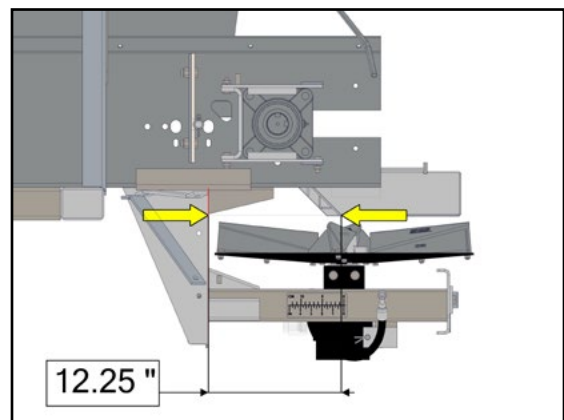

Figure 6

9. Figure 8 - If equipped, Ensure the Hillside Divider is mounted squarely and centered at both the front and the rear. Hillside Divider panel should be perpendicular to ground. Ensure the rear of the panel is centered over the center section of the Material Divider.

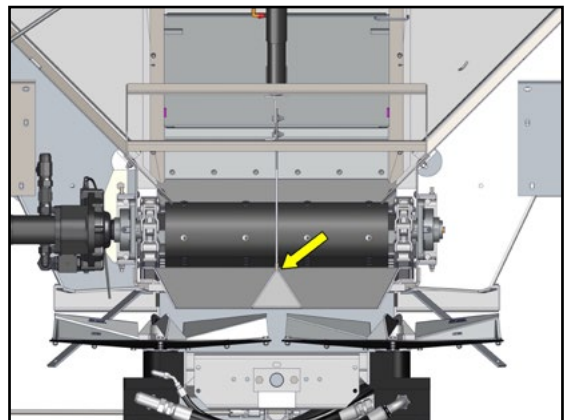

Figure 8

10. Figure 9 - Center the front of the Hillside Divider by measuring from the divider panel to the Chain Shield rubber on each side. Measurements should be equal.

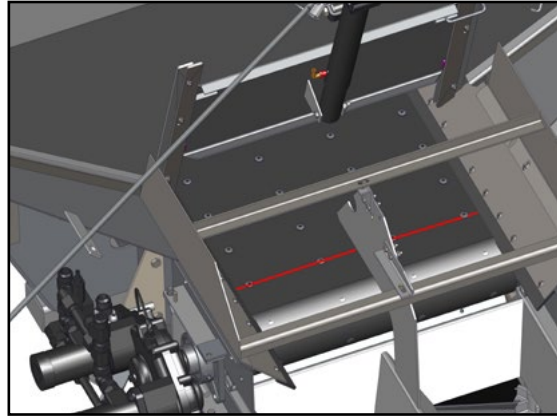

Figure 9

11. Figure 10 - Lastly, ensure that the Hillside Divider panel has proper clearance from the belt. The bottom edge of the divider panel should be approximately 3/8" (1cm) from the rubber belting of a #4 BOC.
12. If adjustments are necessary, loosen the hardware at the Hillside Divider panel as required and adjust as necessary. Once corrected, tighten hardware to proper torque.

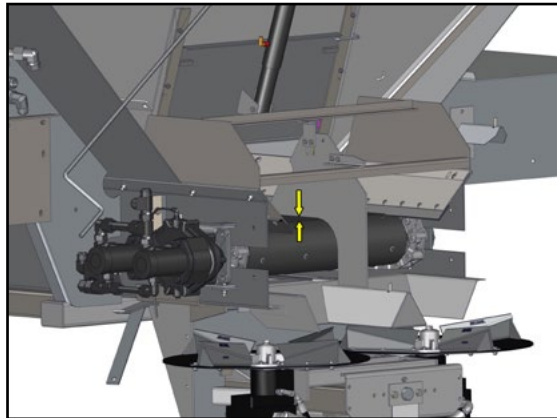

Figure 10

13. Figure 11 - Ensure all guards and shields are securely in place.

The spreader is now ready for field testing.

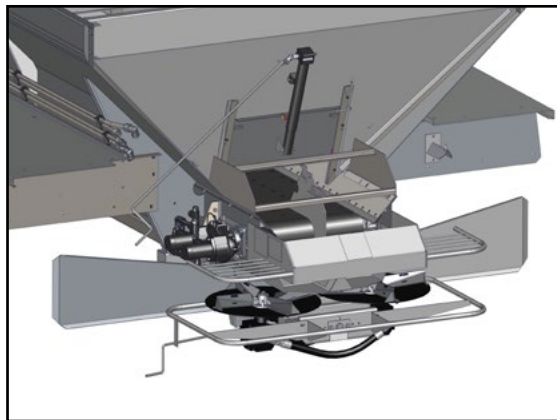

Figure 11

The following procedure is a guide:

NOTE: Do NOT fill spreader with material

1. Field test over any suitable course which allows vehicle to be driven at speeds to be used while spreading.
2. Ensure unit has been properly serviced, that the hydraulic reservoir is full and gate valve under reservoir is fully open. Do not load spreader.
3. Run spinners at 500 RPM.

**DANGER**

Take proper safety precautions when observing conveyor and spinner speed while vehicle is in motion! These may include use of suitable mirrors clamped to permit observation by a safely seated observer, following the spreader in another vehicle at a safe distance, or other suitable means. Do not stand on fenders, in body or on any part of spreader as there is danger of falling off the vehicle or into moving parts! Use great care in performing this test!

4. Start engine. Turn control to "on" position. Engage PTO and allow to run at fast idle long enough to bring hydraulic oil up to operating temperature. Spinners should revolve at moderate speed and the conveyor should not move.
5. Refer to controller's operation manual for conveyor operating instructions. Set program to operational mode and begin forward travel. Move conveyor switch to "on" position. Conveyor should start immediately when vehicle moves and should continue to run at speeds which should vary directly with the vehicle's ground speed; the conveyor should speed up as vehicle speed increases and slow down as vehicle speed reduces. Spinner speed should remain constant when engine speed is above minimum operating range.

1. Make sure unit has been properly serviced and is in good operating condition. It is highly recommended to run the spreader prior to loading material to ensure acceptable operation.
2. Program controller with correct data for material(s) and application.
3. Adjust feedgate to appropriate setting.
4. Adjust spinner to give spread pattern desired. Calibrate and spread pattern test for any new material.
5. Fill applicable bins with material to be spread.
6. Engage hydraulics.
7. Begin spreading.



CAUTION Drive only at speeds which permit secure control of vehicle.

NOTICE!

CHANGE HYDRAULIC OIL FILTER AFTER FIRST WEEK (OR NOT MORE THAN 50 HOURS) OF OPERATION ON A UNIT.

*Visit www.newleadervip.com for interactive tools to calculate yield, proper feedgate opening, conveyor revolutions per minute and mph to maximize the performance of your spreader.

PREVENTATIVE MAINTENANCE PAYS!

The handling and spreading of commercial fertilizers is a most severe operation with respect to metal corrosion. Establish a frequent, periodic preventative maintenance program to prevent rapid deterioration to spreading equipment. Proper cleaning, lubrication and maintenance will yield longer life, more satisfactory service and more economical use of your equipment.

**WARNING**

Shut off all power and allow all moving parts to come to rest before performing any maintenance operation.

HYDRAULIC SYSTEM

Proper oil in the hydraulic system is one of the most important factors for satisfactory operation. Utmost cleanliness in handling the oil cannot be stressed enough. Keep hydraulic oil in original closed containers, clean top of container before opening and pouring, and handle in extremely clean measures and funnels.

Refer to “Lubricant and Hydraulic Oil Specifications” for selection of the proper hydraulic fluid for use in the hydraulic system.

SERVICE SCHEDULE**WARNING**

DO NOT check leaks with hands while system is operating as high pressure oil leaks can be dangerous! If skin is pierced with hydraulic fluid at high pressure seek immediate medical attention as fluid injected into the skin could cause gangrene if left untreated. Relieve pressure before disconnecting hydraulic lines or working system. Make sure all hydraulic fluid connections are tight and all hydraulic hoses and lines are in good condition before applying pressure to the system. Wear protective gloves and safety glasses or goggles when working with hydraulic systems.

**WARNING**

DO NOT check for leaks adjacent to moving parts while system is operating as there may be danger of entanglement!

Check hydraulic oil daily by means of sight gauge on reservoir. Add oil as necessary to maintain level around mid-point of sight gauge. Periodically inspect hoses and fittings for leaks.

NOTICE!

Change hydraulic oil filter after first week (or not more than 50 hours) of operation on a unit.

After first filter change, replace filter when indicator reaches Red Zone.

Drain reservoir through drain plug (not through suction outlet), flush, and refill and change filter element annually. Oil and filter should also be changed whenever oil shows any signs of breaking down under continued high-pressure operation. Discoloration of oil is one sign of breakdown.

HYDRAULIC HOSE

Hose assemblies in operation should be inspected frequently for leakage, kinking, abrasion, corrosion or other signs of wear or damage. Worn or damaged hose assemblies should be replaced immediately.

**WARNING**

Testing should be conducted in approved test stands with adequate guards to protect the operator.

**Clean**

Clean assembly by blowing out with clean compressed air. Assemblies may be rinsed out with mineral spirits if the tube stock is compatible with oil, otherwise hot water at 150°F (65.55° C) maximum may be used.

**Inspect**

Examine hose assembly internally for cut or bulged tube, obstructions, and cleanliness. For segment style fittings, be sure that the hose butts up against the nipple shoulder; band and retaining ring are properly set and tight, and segments are properly spaced. Check for proper gap between nut and socket or hex and socket. Nuts should swivel freely. Check the layline of the hose to be sure the assembly is not twisted. Cap the ends of the hose with plastic covers to keep clean.

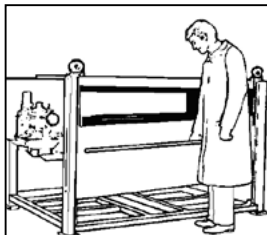
**Test**

The hose assembly should be hydrostatically tested at twice the recommended working pressure of the hose.

Test pressure should be held for not more than one minute and not less than 30 seconds. When test pressure is reached, visually inspect hose assembly for: 1. Any leaks or signs of weakness. 2. Any movement of the hose fitting in relation to the hose. Any of these defects are cause for rejection.

Storage and Handling

Hose should be stored in a dark, dry atmosphere away from electrical equipment, and the temperature should not exceed 90° F (32.22° C).

CONVEYOR CHAIN**WARNING**

Stay out of the hopper body. If it's necessary to enter the hopper, return to the shop, empty body, turn off all power, set vehicle brakes, lock engine starting switch and remove keys before entering. Tag all controls to prohibit operation. Tags should be placed, and later removed, only by person working in the body.

Hose down unit and remove any material build-up on sprockets and under chain.

NOTICE!

The conveyor will move away from the bottom panel if material accumulates under the conveyor or on the sprockets. The more material that accumulates, the closer the chain will come to the chain shields. If the conveyor should catch a chain shield, it could permanently damage the conveyor, the chain shields or the unit. Do not remove material while conveyor or spinner is running!

Lubrication

Make sure unit is clean and completely dry. Lubricate conveyor chain at the end of each day of usage using a mixture of 75% diesel fuel and 25% SAE 10 oil. Shut down spinner and run conveyor at 20 RPM for two full revolutions to lubricate chain. After each unit washing, allow to dry, then lubricate.

Lubricate MULTAPPLIER/MULTIBIN conveyor chain bi-weekly and at end of each season with Fluid Film™ or equivalent. Shut down spinner and run

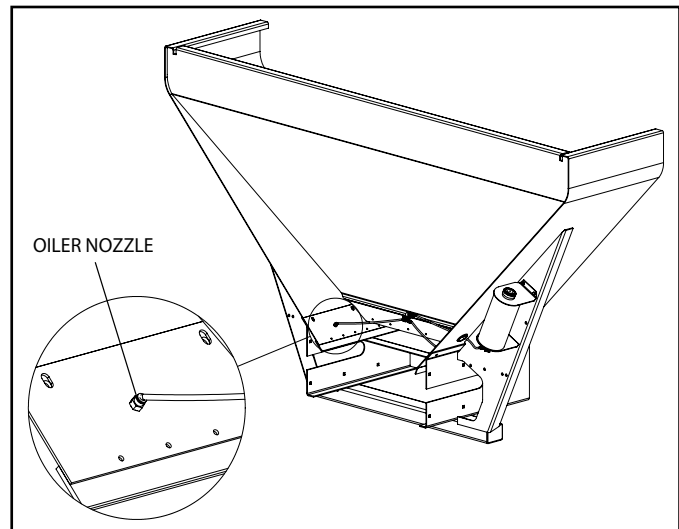

Figure 1 - Spray Nozzle

conveyor at 20 RPM. Lubricate chain through two full revolutions. After each unit washing, allow to dry, then lubricate.

Before filling the unit with spreading material, activate the controller or power switch to run the pump oiler. Bleed all air from the lines and adjust the two spray nozzles so that the oil mixture sprays vertical onto the sprockets and chain.

Tension

Proper chain tension is also a factor in chain and sprocket life. Measure from rear of main unit forward to achieve proper chain tension (Figure 2). Make sure chain is tensioned equally on both sides. This adjustment is made on each side of the unit at the front idler bearings.

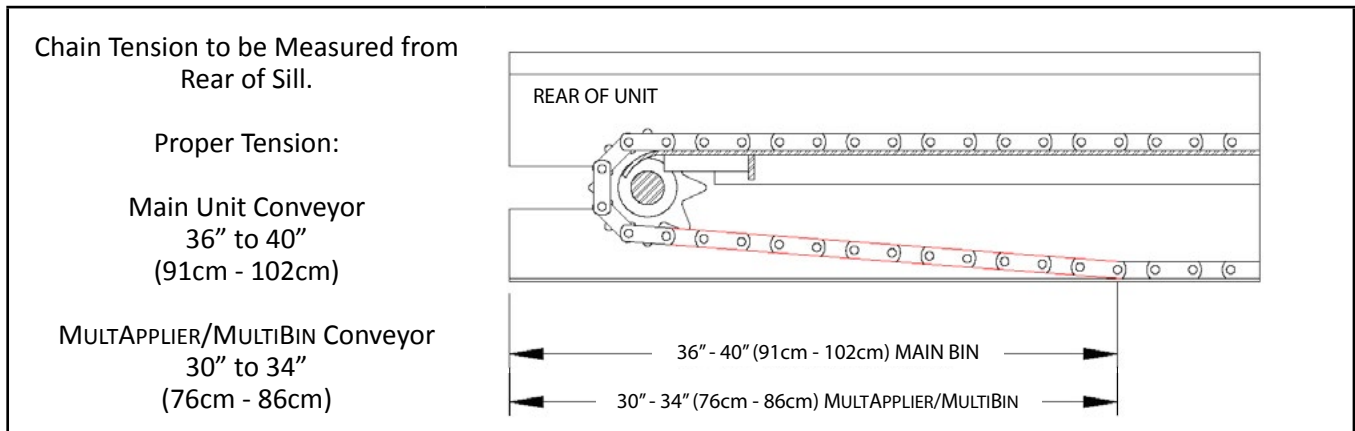

Figure 2 - Chain Tension

Conveyor chains that are too tight will tend to stretch, causing excess sprocket wear and eventually breakage. Excess slack presents the possibility of chain catching on sub-frame parts. Bent or distorted chain bars will cause damage to unit as well as fertilizer leakage with #3 conveyors. Straighten or replace bent or distorted chain bars immediately.

#4 BOC CONVEYOR BELT MAINTENANCE

Standard belting for the #4 conveyor is moderately oil resistant (MOR) that is impervious to moisture, weathering, and normal action which can be used with chemical-impregnated fertilizer or oil-based additives.

- Inspect belt fastener occasionally for wear or "raveling" of belt grip area.
- Make sure belt connecting pin is positioned correctly as shown in Figure 3.

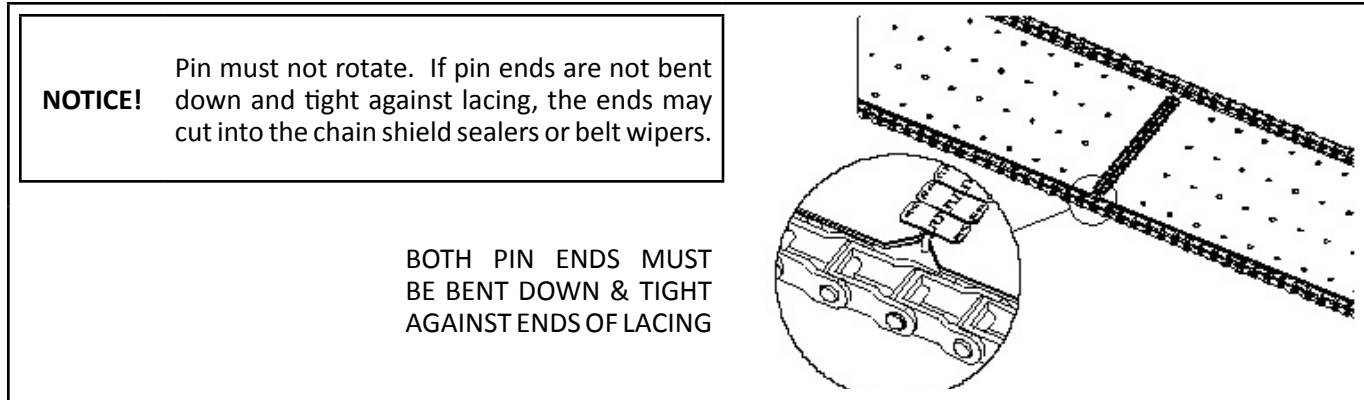

Figure 3 - Conveyor Belt Connecting Pin Installation

#5 STRAIGHT BELT CONVEYOR**WARNING**

Stay out of the spreader. If it's necessary to enter the spreader, return to the shop, empty body, turn off all power, set vehicle brakes, lock engine starting switch and remove keys before entering. Tag all controls to prohibit operation. Tags should be placed, and later removed, only by person working in the body.

MAINTENANCE

The conveyor belt should be checked daily for proper tension and tracking. See "Adjustment" section.

Do not be alarmed as sides of belt wear unless belt is out of track. The belt will continue to operate satisfactorily with up to 1" (2.54cm) total worn from the sides. Inspect belt lacing frequently for wear or "raveling" of belt grip area and loosening hardware. Retighten loose nuts and peen end of lacing screw into slot of nut as required.

ADJUSTMENT1. Tension

Belt tension should be just tight enough to prevent slippage—no tighter. If the “flats” on the conveyor drive pulley are visible through the belt, tension is high enough.

2. Tracking

Empty spreader to check tracking by doing the following:

- A. Make sure vehicle engine is shut off. Set spinner speed. Run PWM spinner control valve at 0 RPM.



WARNING Do not work near rotating spinners. Severe injury can result from contact with moving parts.

- B. Make sure the conveyor is shut off. Measure vertical distance from bottom of sill to conveyor in front of 2nd stake from front. Measurement should be 3" (7.6cm) on both sides of conveyor as shown in Figure 1 & 2. Use front adjusting bolts to tension both sides of conveyor as necessary.
- C. Front idler turnkleen must be square with the conveyor bottom. Measure from front of bearing block to front of sill on both sides. (Figure 3) Move bearings as necessary to make measurements equal.
- D. Verify snubber pulley is secure and square. Measure from bearing block to rear of sill on both sides. (Figure 4) Move bearing blocks in the slotted holes as necessary to make measurements equal.
- E. Run engine, place controller in manual mode (see control manufacturer's manual) and run conveyor at slow speed. Gradually increase speed (40-50 rpm) until tracking is visual. If problems do occur, refer to next page.

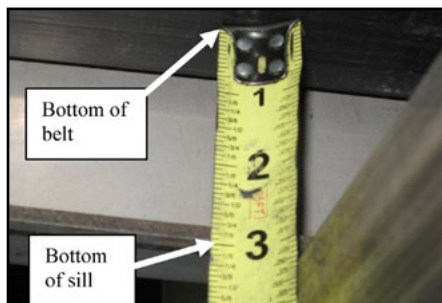

Figure 1

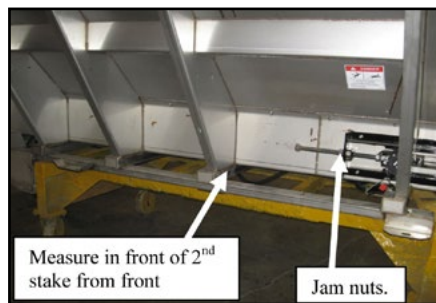

Figure 2

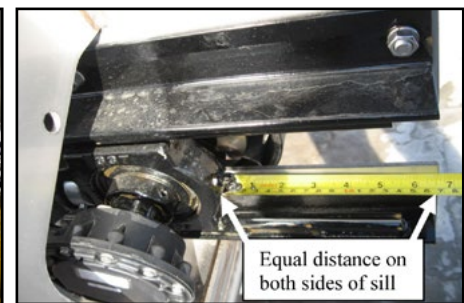

Figure 3



Figure 4

**CAUTION**

Use great care to avoid entanglement with any moving parts.

A properly adjusted belt will either remain in a steady position centered on the pulley or more often will “wander” back and forth 1/4" (.64cm) to 1/2" (1.27cm) across the pulley, but remain generally centered. The conveyor belt sides should not curl or scuff.

Improper tracking is usually due to one of three basic causes. These problems and their respective solutions follow:

PROBLEM 1: (Figure 5)

Belt tracks to one side, contacts side of conveyor. Contact is more severe at the front and may not quite touch at the rear.

SOLUTION:

Tighten idler bearing at side in contact with belt. Make this adjustment one turn at a time. Operate conveyor 10 to 15 minutes at a high speed to allow belt to react to the adjustment. Repeat if necessary.

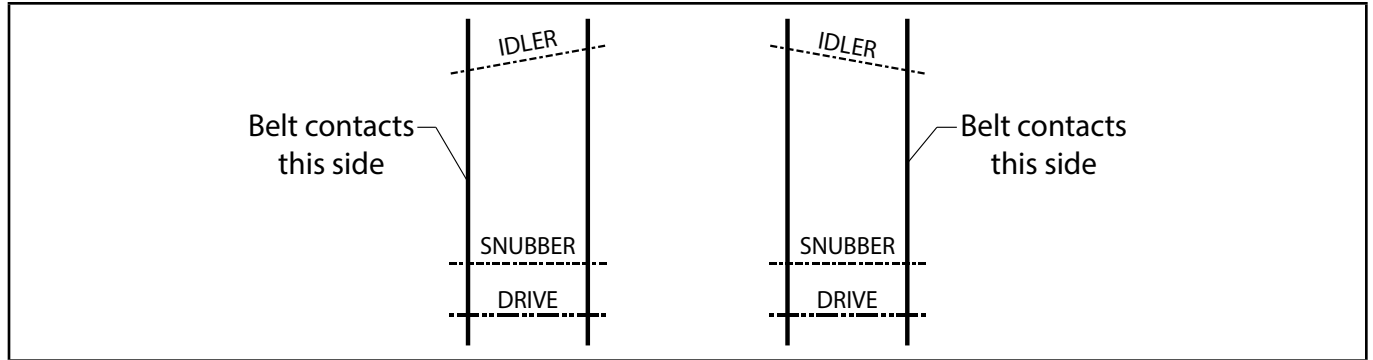

Figure 5

PROBLEM 2: (Figure 6)

Belt contacts one side at front and contacts other side at rear.

SOLUTION:

If adjusting as in Problem 1 does not remedy the situation, adjustment of the drive pulley is necessary. Mark the position of the adjustment screw (RH side) on the side of the unit. Determine which illustration shows the problem to figure out which direction the drive shaft should be moved. Loosen the adjustment screw to move the shaft forward; tighten the screw to move the shaft rearward.

NOTE: The illustration is exaggerated. Only move the adjustment screw 1/4 (.64cm) turn at a time after loosening the bolts holding the bearing. Usually, 1/64 (.04cm) to 1/32 (.04cm) inch adjustment is all that is necessary. Retighten bearing. Operate conveyor for 10 to 15 minutes at a high speed to allow belt to react to adjustment. The problem should change to Problem 1. Adjust as in Problem 1 to track belt properly.

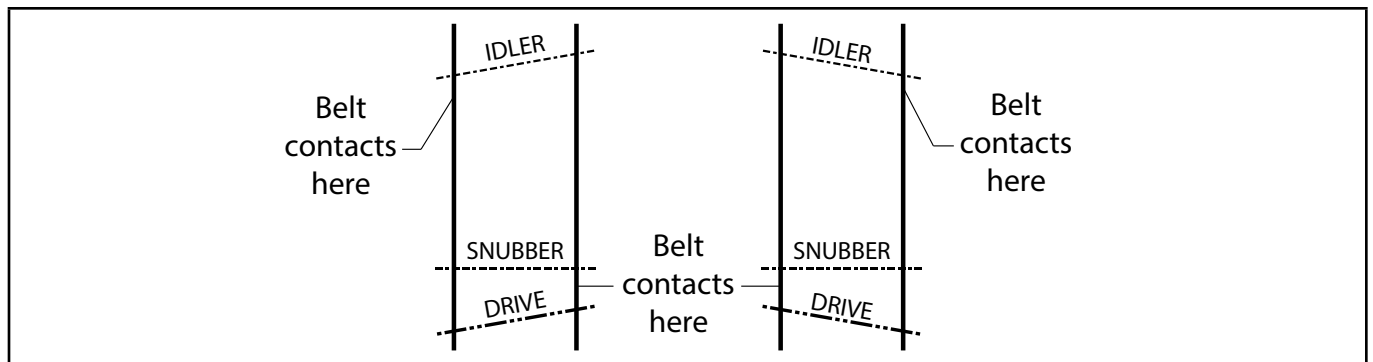

Figure 6

PROBLEM 3: (Figure 7)

Belt contacts side as in Problem 1, but contacts more heavily at a point approximately three feet from rear.

SOLUTION:

Realign snubber pulley. Note the point or side of contact from the illustration. This side of the snubber is too low.

NOTE: This pulley moves up and down ONLY.

Loosen belt and raise or lower as necessary. Loosen the two bolts holding the snubber bearing on the side to be adjusted after marking the old position. Move approximately 1/16 (.16cm) inch at a time and retighten. Retighten belt the exact number of turns previously loosened. Operate conveyor 10 to 15 minutes to allow belt to react to adjustment. Refer to Problem 1 and readjust. If readjustment does not compensate, repeat.

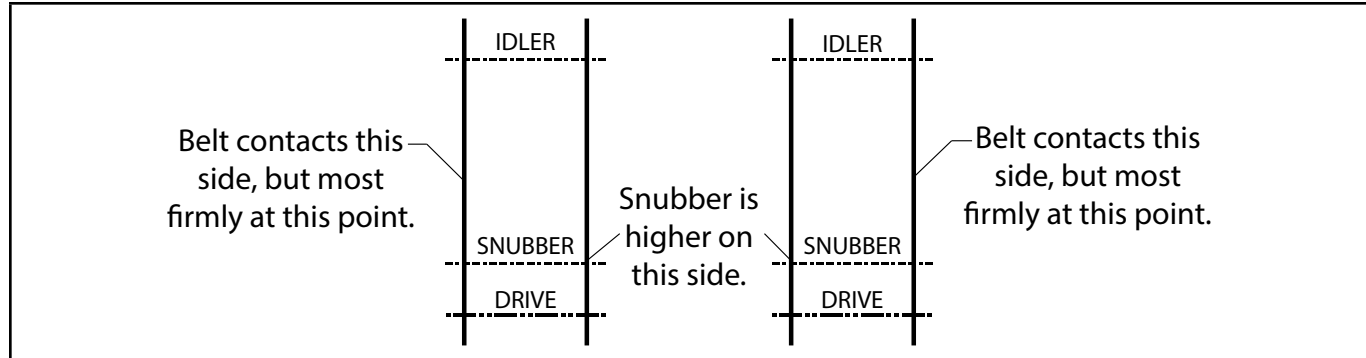

Figure 7

If, after continued adjustment, the belt does not track properly, check the following:

1. Check for twisted spreader body. Shims must be placed between spreader cross tubes and the mounting surface to eliminate any twist in the body structure.
2. Check for crowned Idler Pulley by placing a straight edge on the pulley. If properly crowned, the straight edge will contact the center pulley leaving 1/16 (.016cm) inch gap between the straight edge and both pulley ends. Replace the pulley if crown is not present.
3. Check for lacing squareness by removing the belt. This should be done as a last resort. If the lacing is not square to the belt ends, contact your local New Leader dealer for service.
4. Sight down the body under the belt shields. The only point which should come close to, or slightly contact the belt, is the lowest point on the shield. If the belt contacts the shield firmly at any other point, tracking will be impossible. See your local New Leader dealer immediately.

BELT SHIELDS

The belt shields, located along each side of the belt inside the unit, should be just contacting the belt when the belt is properly adjusted and the hopper is empty (Figure 8). If a shield has clearance along its length, it can be adjusted until it just contacts the belt by loosening the fastener bolts, allowing the shield to slide downward and tightening the bolts. If the shield tends to cut into the belt along its full length, loosening the bolts and raising the shield until it just contacts the belt will correct the problem.

If the shield cuts the belt at one or more points or if it gaps at one or more points, it should be replaced.

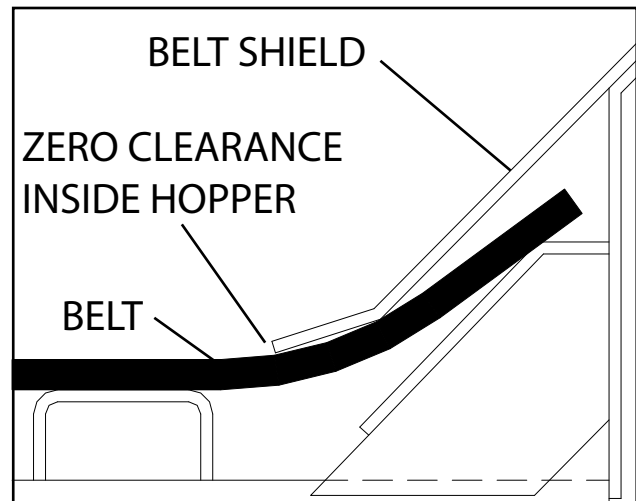

Figure 8 – #5 Bottom

NOTICE! Do NOT lubricate the #5 belt. Use of lubricants will cause the belt to deteriorate and fail prematurely.

REMOVAL & REPLACEMENT

Tools and Equipment Required (NOTE: Two people MUST be used for this procedure.):

1. 1 1/2" Hex Wrench
2. 25 to 30 Feet (762cm – 914.4cm) of 1/4" (.64cm) to 3/8" (.95cm) Rope.
3. 3 or 4 Pieces of 2 x 4 (5.08cm x 10.16cm) Lumber about 3 Feet (91.44cm) Long.
4. 10 (304.5cm) Feet of 14 or 16 Gauge Soft Iron Wire.

Procedure:

1. Unplug the PWM valve to disable spinners.
2. Remove both belt shields, clean thoroughly and repaint as necessary.
3. Adjust controller to Manual operation. Select a slow Manual Speed so tracking is visual.
4. Run conveyor until belt splice is accessible at rear of spreader. Shut machine down and remove key.
5. Loosen the front idler adjustment bolts all the way.
6. Pull out splice pin to separate belt splice.
7. Insert pin into one side of belt splice. Attach a winch to the belt splice and remove belt.
NOTE: If the splice pin cannot be removed, cut belt and remove belt by hand.
8. Remove any caked material from the drive pulley, snubber pulley, idler pulley and from inside the frame channels. Clean and repaint as necessary.
9. Thread OLD splice pin through one end of new belt splice. Connect wire to pin about 1/4" (.64cm) in from each side of the belt, forming a loop.
10. Thread the rope along the top of the belt channel, around the front idler pulley, over the snubber pulley, and under the drive pulley.



CAUTION Make sure power is shut off before performing threading operation.

11. Tie end of rope under drive pulley to wire loop. Wrap other end of rope once around drive pulley and out to rear.
12. Start conveyor drive so drive pulley turns slowly. One person should pull on rope while other feeds belt into unit from rear. Pull new belt under drive pulley, over snubber pulley, along frame channels, around front idler pulley and back to drive pulley.



CAUTION Use extreme care to avoid entanglement! Someone must stay at controls to stop conveyor instantly if required.



CAUTION Use extreme care to avoid entanglement! Stand well back from drive pulley.

13. Shut off all power and insert lumber under belt to support its weight as shown in Figure 9.
14. Insert a plastic tube in each splice and across the full width of the belt and pull the two ends together at the center of the rear face of the drive pulley.
15. Insert the splice pin (flexible, plastic covered).
16. Snug the belt up by tightening the idler pulley.
17. Tighten the belt until the edge of the belt is approximately 3" (76mm) above the lower edge of the sill lower flange on each side. Remove lumber.
18. Adjust for proper tracking as outlined in the *Belt Conveyor Adjustment* section of this manual.

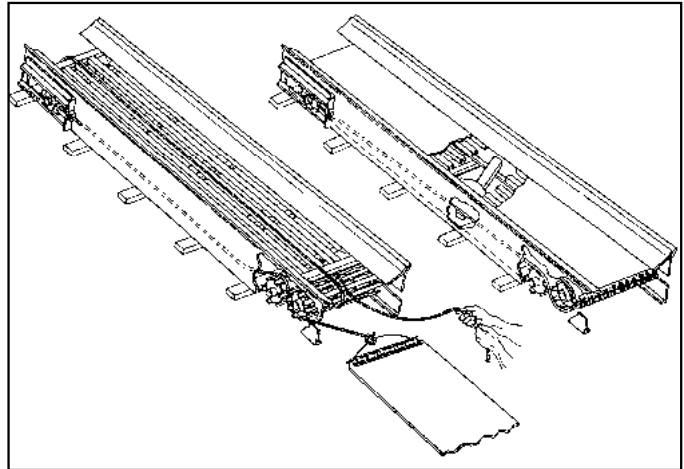

Figure 9— #5 Belt Installation

CONVEYOR GEARCASE

Drain oil in a new unit after first two weeks (or not more than 100 hours) of operation, and flush gear case thoroughly with light oil. Refer to “Lubricant and Hydraulic Oil Specifications” section for proper grade oil and recommended amounts of lubricant. After initial change, oil should be changed every 2,000 hours of operation or annually, whichever occurs first.

Check gearcase oil level monthly.

BIN SENSOR**WARNING**

Stay out of the spreader. Do not climb on spreader. Use a portable ladder to inspect, clean and maintain the bin sensor from outside the spreader. Failure to do so could result in injury from falling.

NOTICE!

Wipe sensor clean periodically to prevent accumulation of product. Avoid wet material as it may stick to sensor. If material sticks to sensor it won't warn user when bin is low.

Clean sensor with long handled brush or hose from outside of spreader. Do not aim high pressure sprayer directly at sensor—it could damage the components.

LUBRICATION OF BEARINGS

Grease in a bearing acts to prevent excessive wear of parts, protects ball races, and balls from corrosion and aids in preventing excessive heat within the bearing. It is very important the grease maintain its proper consistency during operation. It must not be fluid and it must not channel.

Make sure all fittings are thoroughly cleaned before grease is injected. Points to be lubricated by means of a grease gun have standard grease fittings.

Lubricate bearings by pumping grease slowly until it forms a slight bead around the seals. This bead indicates adequate lubrication and also provides additional protection against the entrance of dirt.

FASTENERS

Tighten all screws fasteners to recommended torques after first week of operation and annually thereafter. If loose fasteners are found at anytime, tighten to recommended torque. Replace any lost or damaged fasteners or other parts immediately. Check body mounting hardware every week.

CLEAN-UP**NOTICE!**

High pressure wash can inject water and/or fertilizer into control components, causing damage. Use caution when cleaning these areas.

Thoroughly wash unit every two to three days during the operating season to maintain minimal maintenance operation. Hose unit down under pressure to free all sticky and frozen material.

It is important the unit be thoroughly cleaned at the end of each operating season. All lubrication and maintenance instructions should be closely followed. Repaint worn spots to prevent formation of rust.

Spinner Fins

Visually inspect spinner fins daily for build-up of material and wear. Spinner discs and fins must be kept clean and polished. Even a small build-up of material on a spinner can significantly affect the spread pattern. Rough, bent or worn fins will produce poor spread patterns. Replace worn fins and discs as needed. See *Fin Kit Installation Instructions* for replacement part numbers and instructions.

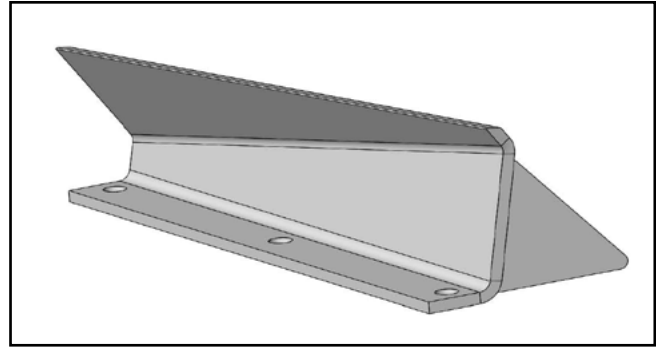
**Figure 1 - Spinner Fin****Spinner Deflectors**

Visually inspect spinner deflectors daily for build-up of material and damage. Clean as needed. Even a small build-up of material on a spinner deflector can affect the spread pattern. If damaged, bent or otherwise, replace. See parts manual for replacement part numbers.

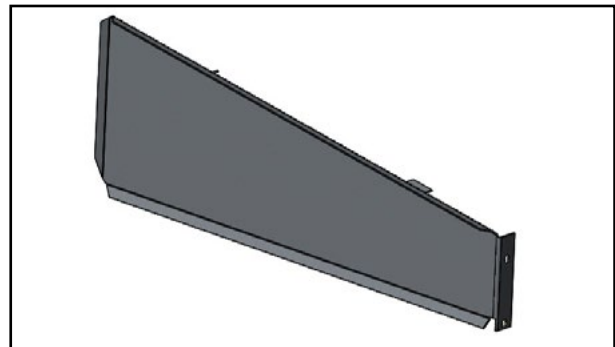
**Figure 2 - Spinner Deflector****Material & Hillside Flow Dividers**

Visually inspect material divider and hillside flow dividers (as equipped) daily for build-up of material and wear. Any build-up of material on divider components can affect performance. Clean as needed. Replace worn or damaged parts as necessary. See parts manual for replacement part numbers.

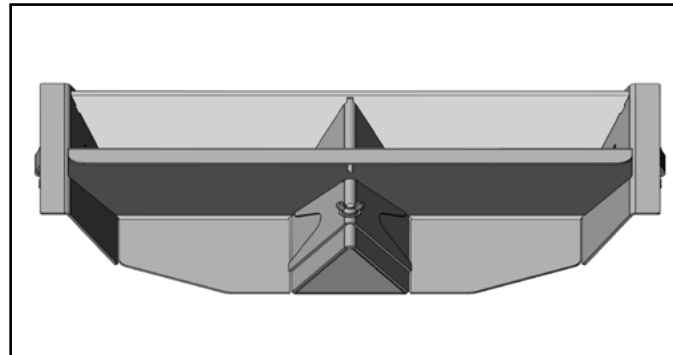
**Figure 3 - Material Divider**

HYDRAULIC SYSTEM

Use premium quality lubricants with 100-200 SUS or 20-43 cSt viscosity at operating temperatures. The hydraulic fluid's specifications in the table below are for normal operating conditions. Extreme environments or dirty conditions may require the use of different oils. Consult your New Leader dealer or the Product Support Department at Highway Equipment Company for systems operating outside normal conditions.

Ideal Oil Operating Temperature	115-158°F (46.11-70° C)
Recommended Premium Lubricant	Multi-Purpose Agriculture Hydraulic & Transmission Oil
Lubricant Specifications	
Viscosity Index	Greater than 130
Viscosity at 40°C, cst	Less than 68
Viscosity at 100°C, cst	Greater than 9
Acceptable Fluid Example	John Deere Hy-Gard® J20C

GEARCASE LUBRICANT

Lubricate these assemblies with non-corrosive type extreme pressure (E.P.) gear oil conforming to MIL-L2105 B multi-purpose gear lubricating oil requirements (API Service GL 4) based on ambient temperatures listed below. Refill gear case with one and a half (1-1/2) pints (.70 liters) of recommended lubricant.

Ambient Temperature	Below 40° (4.44°C)	Between 40° (4.44°C) and 100° (37.77°C)	Above 100° (37.77°C)
Oil Type	SAE 80 E.P.	SAE 90 E.P.	SAE 140 E.P.

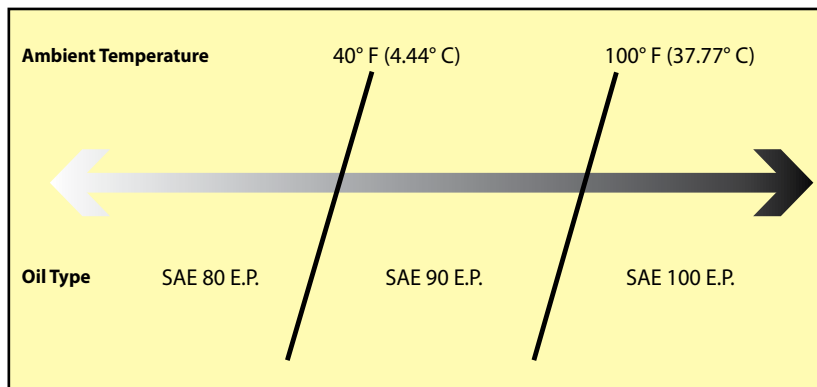

GREASE GUN LUBRICANT

Use a waterproof ball and roller bearing lithium base lubricant with a minimum melting point of 300°F (148.8° C). This lubricant should have a viscosity which assures easy handling in the pressure gun at prevailing atmospheric temperatures. The grease should conform to NLGI No. 2 consistency.

CHAIN CONVEYORS

Use a mixture of 75% No. 1 or No. 2 diesel fuel or kerosene mixed with 25% SAE 10 engine oil in the main unit conveyor chain oiler.

**WARNING**

Shut off all power and allow all moving parts to come to rest before performing any maintenance operation.

The spreader should be regularly lubricated with the lubricants recommended in this manual in accordance with the following chart:

Location	Places	Method	Frequency
Transmission PTO			
Slip Yoke	1	Grease Gun	Weekly
Universal Joint	2	Grease Gun	Monthly
Hydraulic System			
Reservoir	1		Check Daily. Change Annually
Filter	1	Check daily; Change when indicated (Red)	
Conveyor			
Grease Zerks - Dragshaft Bearings (A)	2	Grease Gun	Weekly
Grease Zerks - Idler Shaft Bearings (B)	2	Grease Gun	Weekly
Take-Up Screws (C)	2	Hand Grease	Weekly
Grease Zerks - Snubber Pulley Bearings (D)	2	Grease Gun	Weekly
Gearcase	1	Gear Oil	Check Monthly; Change Annually
Feedgate Jack Assembly			
Grease Zerks (E)	1	Grease Gun	Annually
Spinner			
Grease Zerks - Shaft (F)	2	Grease Gun	Weekly
Grease Zerks - Jack (G)	2	Grease Gun	Weekly
Bin 2 Conveyor			
Grease Zerks - Dragshaft Bearings (H)	2	Grease Gun	Weekly
Grease Zerks - Idler Shaft Bearings (J)	2	Grease Gun	Weekly
Take-Up Screws (K)	2	Hand Grease	Annually

NOTE: Unusual conditions, such as excessive dust, temperature extremes or excessive moisture may require more frequent lubrication of specific parts.

*See "Lubricant and Hydraulic Oil Specifications" for types of lubricants and oil to be used.

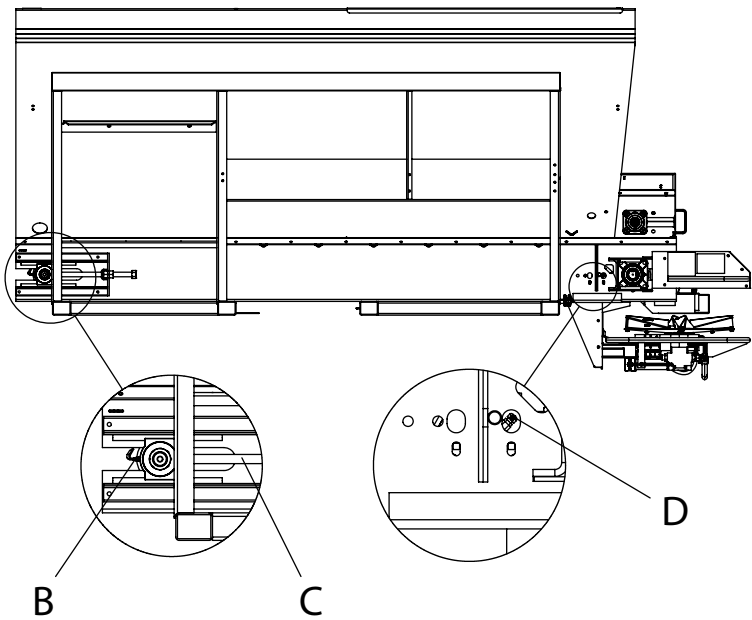
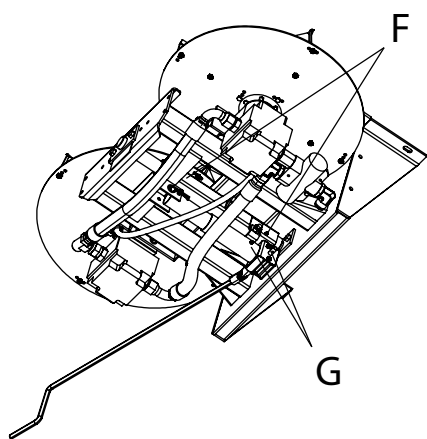
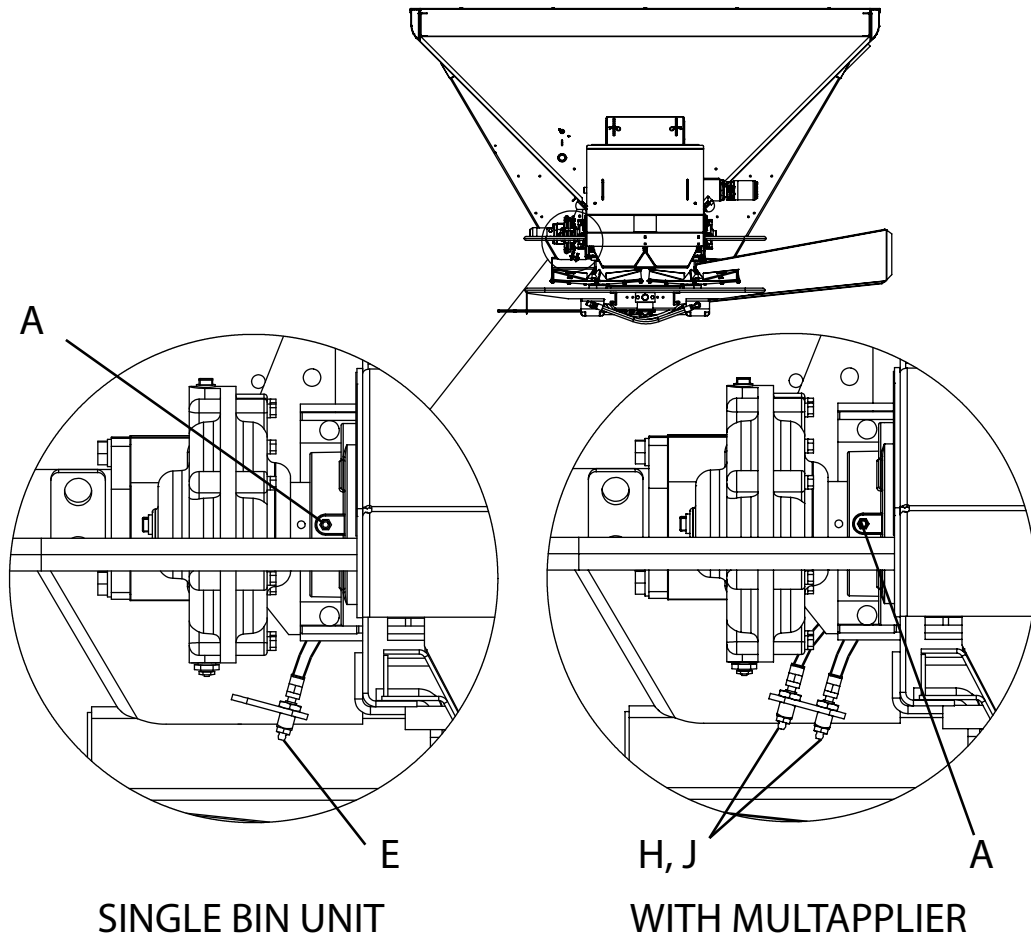

NOTE: SOME COMPONENTS HIDDEN FOR CLARITY

Symptom:	Reason:	Correction:
Spinner will not run	Defective Spinner Control Valve	Replace spinner control valve cartridge and coil.
	No voltage at valve	Verify spinner switch is on.
		Verify spinner enable is checked.
		Verify controller has a target spinner RPM entered.
		Verify spinner control harness is not damaged.
		Verify system was configured as Basic independent.
	No hydraulic flow	Verify hydraulics are on.
Pressure test pump - replace as needed.		
System is going over relief - test & replace as needed.		
Spinner will not shut off	Defective spinner control valve	Replace spinner control valve cartridge.
	Control valve is manually overrode	Loosen jam nut on control valve cartridge and back set screw out until spinner stops.
Spinner runs erratic	Defective spinner control valve	Replace spinner control valve cartridge.
	Spinner speed sensor harness failure	Replace sensor harness.
	Spinner speed sensor not properly installed	Adjust sensor so that gap between sensor and fin mounting bolt is less than 1/8".
Spinner speed drops off when turning around	Improper control settings	Verify PWM control is set properly (HOLD for gear pumps, CONTROL for variable displacement).
Spinner speed does not hit target	Defective spinner control valve	Replace spinner control valve cartridge.
	Pump failure	Flow and pressure test pump.
	Spinner speed sensor not properly installed	Adjust sensor so that gap between sensor and fin mounting bolt is less than 1/8".
	Hydraulic flow dropping off	Adjust settings and speed. Pressure test relief (adjust or replace as needed).
	Spinner speed sensor harness failure	Replace sensor harness.
	Spinner speed sensor failure	Replace spinner speed sensor.
Conveyor will not run	Defective conveyor control valve	Replace conveyor valve cartridge.
	No voltage at valve	Verify bin switch and master switches on.
		Verify in controller that target rate, density, ground speed and a CFR number are all entered.
		Verify conveyor control harness is not damaged.
	No hydraulic flow	Verify hydraulics are on.
		Pressure test pump - replace as needed.
		System is going over relief - test & replace as needed.
		Conveyor is going over relief - test & replace as needed.

Symptom:	Reason:	Correction:
Conveyor will not shut off	Defective conveyor cartridge	Replace conveyor control valve cartridge.
	Control valve is out of time	Adjust cartridge timing.
Conveyor runs erratic	Defective conveyor cartridge	Replace conveyor control valve cartridge.
	Encoder failure	Replace encoder.
	Encoder harness failure	Replace harness.
	Rates smooting is disabled	Enable rate smoothing.
Bin will not hit target rate	Defective conveyor cartridge	Replace conveyor control valve cartridge.
	Pump failure	Flow and pressure test pump.
	Going over relief	Adjust setting and speed. Pressure test relief (adjust or replace as needed).
	Encoder failure	Replace encoder.
	Encoder harness failure	Replace harness.
Hydraulics over-heating	Pump failure	Flow and pressure test pump.
	Too much flow	Flow test pump.
	System relief	Pressure test relief (adjust or replace as needed). Adjust settings and speed.
	Conveyor valve relief	Pressure test relief (adjust or replace as needed). Adjust settings and speed.
	Oil cooler fan failure	see oil cooler fan failures.
	Case drain on mono valve is plugged.	Case drain requires zero pressure line back to tank.
Oil cooler fan failure	No power at fan	Verify FAN 30-amp fuse is not blown. Verify relay is working properly.
	Fan failure	Replace fan.
Bin level sensors not working properly	Not enabled	Verify system was configured with bin level snesors installed.
	Bin level sensor failure	Replace sensor.
	Bin level sensor harness failure	Replace harness.
Not applying correct rate	Incorrect settings	Verify density, swath width, gate opening, encoder pulses, and CFR number are all adjusted as needed.
No ground speed	Manual speed is enabled, but set to 0	Enter correct speed or disable manual speed
	AUX broadcast speed is enabled but radar not installed	Disable broadcast AUX speed.
	Incorrect speed source is selected	Select correct speed source.

CAP SCREW GRADE IDENTIFICATION - MARKINGS ON HEAD

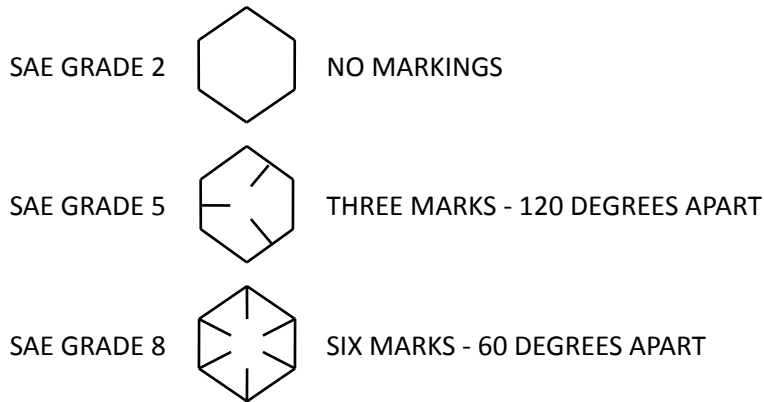

USE GRADE 2 TORQUES FOR STAINLESS STEEL FASTENERS AND CARRIAGE BOLTS.

CAP SCREW SIZE	TORQUE - FOOT-POUNDS					
	GRADE 2		GRADE 5		GRADE 8	
	DRY	LUBE	DRY	LUBE	DRY	LUBE
1/4"	5	4	8	6	12	9
5/16"	11	8	17	13	25	18
3/8"	20	15	30	23	45	35
7/16"	30	24	50	35	70	55
1/2"	50	35	75	55	110	80
9/16"	65	50	110	80	150	110
5/8"	90	70	150	110	220	170
3/4"	100	120	260	200	380	280
7/8"	140	110	400	300	600	460
1"	220	160	580	440	900	650

IMPORTANT! Do not operate or work on machine without reading and understanding the operator’s manual.

Before starting engine/before starting machine operation

- | | |
|--|---|
| <input type="checkbox"/> Program rate controller and document settings | <input type="checkbox"/> Hydraulic hoses are secured properly |
| <input type="checkbox"/> All stop, tail, and turn lights function properly | <input type="checkbox"/> Gearcase oil level is correct |
| <input type="checkbox"/> Tire pressures are equal on each side of chassis | <input type="checkbox"/> Safety shields in place |
| <input type="checkbox"/> Battery condition and connection | <input type="checkbox"/> Spinner Assy moves through full range of operation |
| <input type="checkbox"/> Electrical connections are tight and secure | <input type="checkbox"/> Spinner discs and fins installed properly |
| <input type="checkbox"/> All fasteners are secure | <input type="checkbox"/> Spinner discs and fins are in acceptable condition |
| <input type="checkbox"/> Inverted “V” is secure and installed properly | <input type="checkbox"/> Material Divider assembly is square and secure |
| <input type="checkbox"/> Sensor(s) are functioning properly | <input type="checkbox"/> Material Divider is clean of build-up |
| <input type="checkbox"/> Lubricate all grease fittings | <input type="checkbox"/> Feedgate assembly is level |
| <input type="checkbox"/> Hydraulic oil level and line connections are tight | <input type="checkbox"/> Encoder installed and secured |
| <input type="checkbox"/> Hydraulic filters are current and gauge is functional | <input type="checkbox"/> Spinner sensor adjusted to proper gap |
| <input type="checkbox"/> Chain oiler tank is full and operates correctly | |

Start engine/Start and run to operational temperatures

- | | |
|--|--|
| <input type="checkbox"/> Hydraulic fittings are tight, no leaks * | <input type="checkbox"/> Conveyor control valve is operating correctly |
| <input type="checkbox"/> Check operation of all alarms | <input type="checkbox"/> Calibrate radar/ground speed input |
| <input type="checkbox"/> Hydraulic flow test: ___ GPM @ operating engine RPM | <input type="checkbox"/> Test maximum conveyor(s) RPM |
| <input type="checkbox"/> Check main relief valve setting : ___ PSI | <input type="checkbox"/> Test right and left hand spinner speed; ensure difference is less than 30 RPM (when at operating RPM) |
| <input type="checkbox"/> | |

Stop operation/Turn off engine and engage parking brake

- | | |
|---|--|
| <input type="checkbox"/> Visually check for leaks | <input type="checkbox"/> All oil levels full |
| <input type="checkbox"/> Check belt/chain tension and alignment | |

Perform Calibrations

- Product density testing, crush strength, and SGN scale (See *Spread Pattern Calibration* section for instructions).
- Catch tests of all products and at least 1 blend for conveyor calibration and document settings and product characteristics
- Spread pattern tests of all products and at least 1 blend and document settings and product characteristics

End of Season

- | | |
|---|---|
| <input type="checkbox"/> Empty unit of all material | <input type="checkbox"/> Clean unit inside and out |
| <input type="checkbox"/> Sand and touch-up paint as necessary | <input type="checkbox"/> Check for leaks |
| <input type="checkbox"/> Wash chain conveyor, lubricate thoroughly when dry | <input type="checkbox"/> Lubricate all grease fittings |
| <input type="checkbox"/> Check spinner discs and fins for wear | <input type="checkbox"/> Ensure all fasteners are secure and properly torqued |

This page is intentionally left blank.

NOTES

HYDRAULIC SYSTEM SERVICE VIDEOS



Click or Scan - John Deere Enable Valve Test Procedure



Click or Scan - Relief Valve Setup & Hydraulic Pump Pressure Test Procedure



Click or Scan - PWM Spinner Control Valve 12-Volt Override Procedure



Click or Scan - PWM Spinner Control Valve Manual Override Procedure



Click or Scan - New Leader Conveyor Control Valve Adjusting to Full Off Procedure



Click or Scan - Surging Conveyor Test

HYDRAULIC SCHEMATICS

The following pages contain representative hydraulic schematics for the NL200/300 model spreaders.

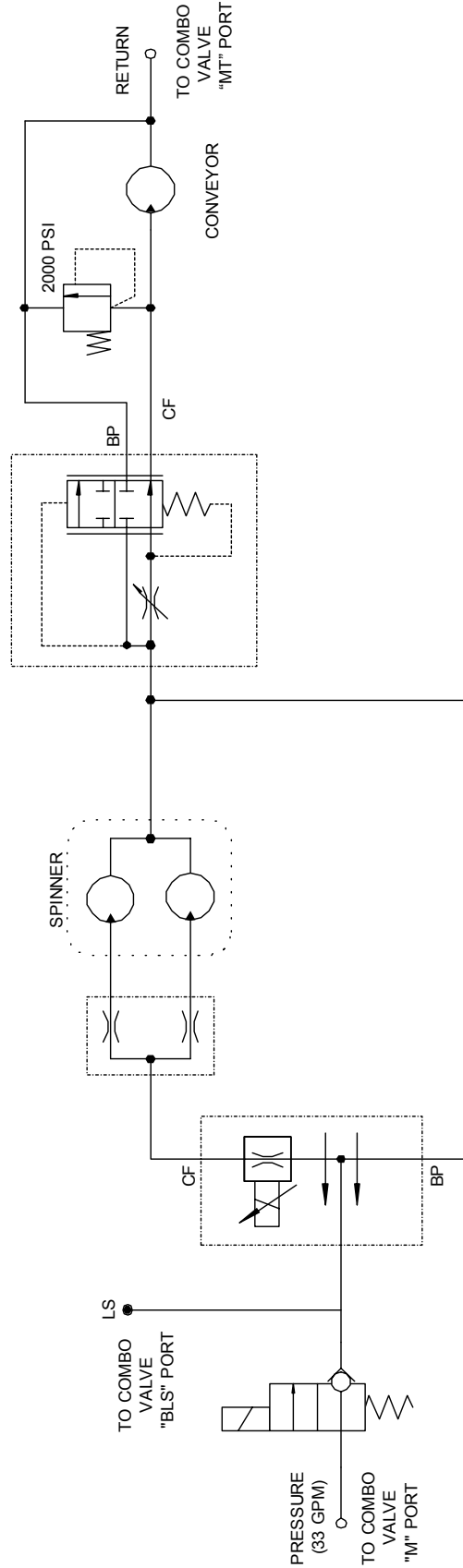

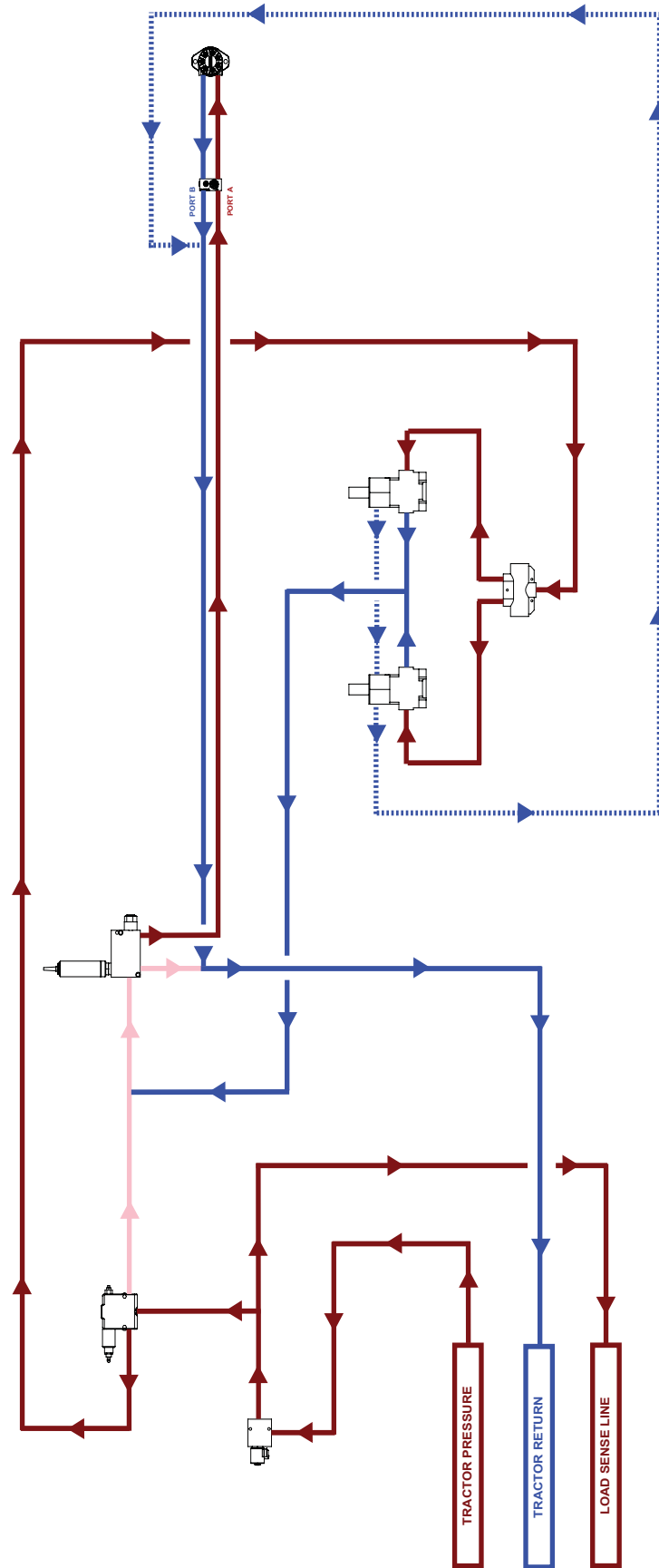

LEGEND

	CONTROL FLOW (HIGH PRESSURE)
	EXCESS FLOW (HIGH PRESSURE)
	RETURN FLOW (LOW PRESSURE)
	CASE DRAIN (LOW PRESSURE)
	SUCTION FLOW (LOW PRESSURE)
	PRESSURE ONLY (HIGH PRESSURE)

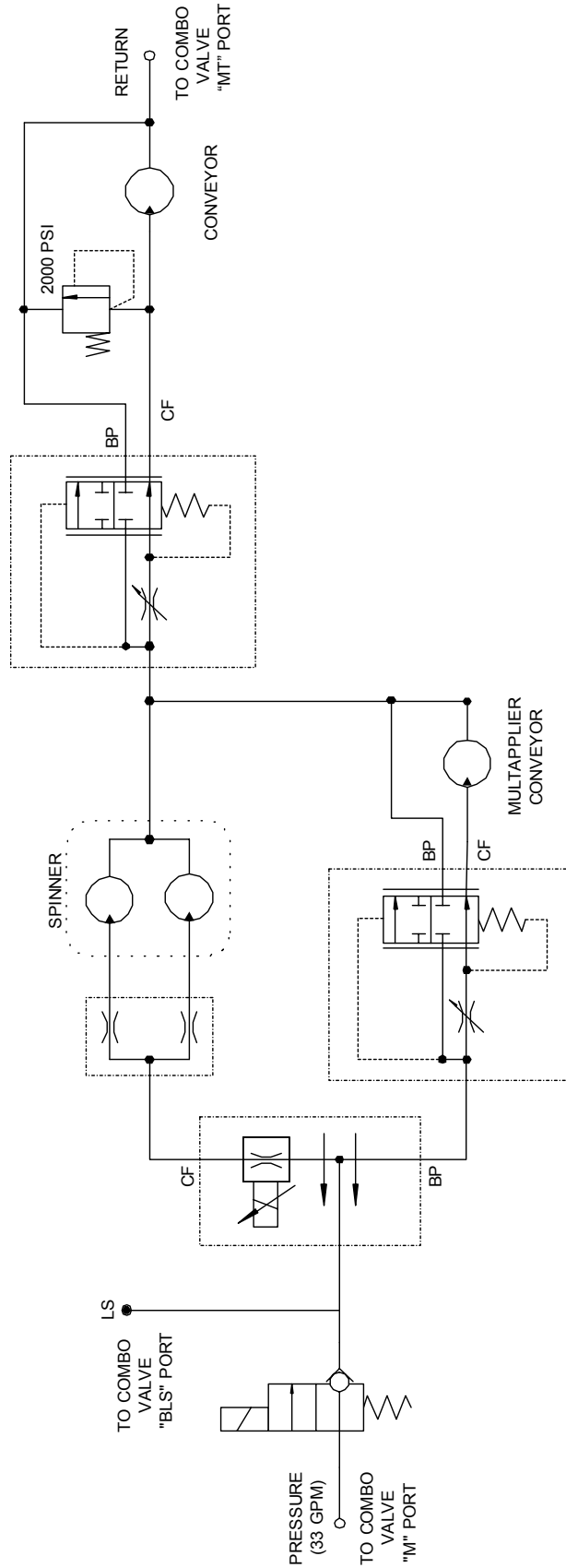

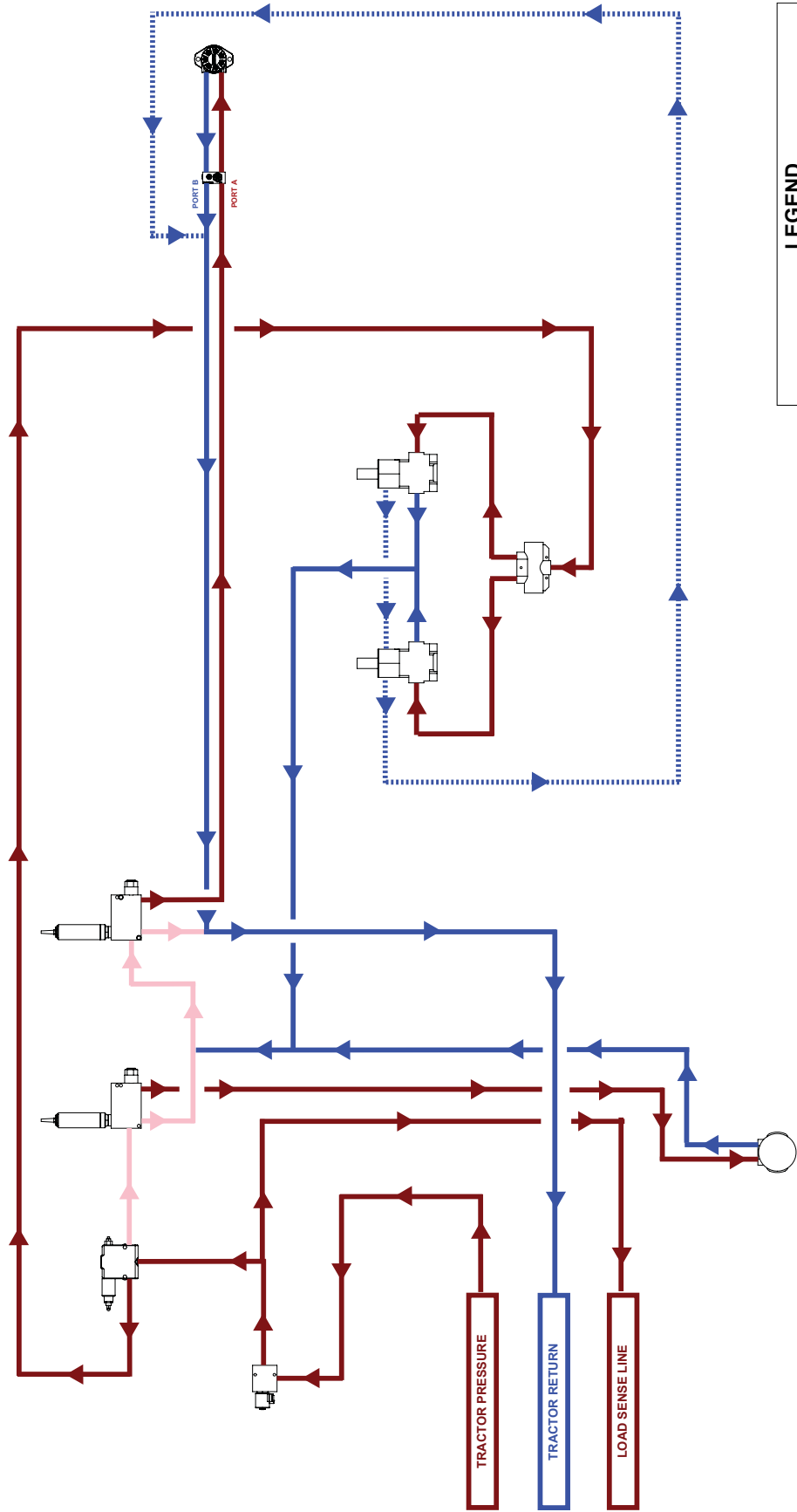

LEGEND

	CONTROL FLOW (HIGH PRESSURE)
	EXCESS FLOW (HIGH PRESSURE)
	RETURN FLOW (LOW PRESSURE)
	CASE DRAIN (LOW PRESSURE)
	SUCTION FLOW (LOW PRESSURE)
	PRESSURE ONLY (HIGH PRESSURE)

HYDRAULICS

This page is intentionally left blank.

NOTES

The following information will guide you through using the SGN & Crush Strength Test Kit for your New Leader G4 Spreader. Refer to operator's manual for details on unit safety, operation and maintenance.

PART NUMBER	DESCRIPTION	QUANTITY
308907	Kit - SGN & Crush Strength Test Kit	1
308908	Tester - Crush Strength	1
308909	Scale - SGN	1

**WARNING**

Use great caution while working around the spreader. Contact with spinners and other moving parts is very dangerous. Do not adjust while machinery is moving, wear eye protection and avoid discharge from spinners. Do not ride on moving spreader.

It is highly recommended to perform a Catch Test, Crush Strength Test and SGN Scale Test prior to each season, before using a new product, or if a significant visible change has occurred with a product. Testing will define granular characteristics and help determine proper spinner settings for optimal product spread.

Conduct a G4 Spread Pattern test to check settings based on test results. Refer to *G4 Spreader Installation Instructions* and *G4 Spread Pattern Manual* for installation and adjustment instructions.

CRUSHING STRENGTH

Crushing strength is the minimum pressure needed to crush individual particles.

Testing and knowing the crushing strength of a particular product will help determine maximum spinner RPM. For example: Any granule with less than three (<3) crush strength should not be broadcast with spinner speeds over 700RPM. Verify granules are not pulverized before increasing spinner speed. Refer to *Product Setup Guidelines* for additional spinner speed settings with different crush strength.

SGN

SGN (Size Grade Number) is the measurement of granule size in millimeters multiplied by 100. A product's SGN will affect spread width.

Materials with poor uniformity (a significant percentage in 3 or more columns of scale device) may be difficult to spread accurately. Spread Pattern testing should ALWAYS be performed on any new or different material to determine actual spread width.

CATCH TEST

The CFR number, or cubic feet per revolution number, is a calibration constant entered into the controller to determine rate output from the spreader's conveyor. A catch test is performed to verify accurate rate output per the controller.

NOTE: SGN and Crush Strength together determine spread width.

General Rules:

A small product with low crush strength will have limited spread width capabilities. Spinner RPM must remain lower to keep from pulverizing the soft product, limiting your overall spread width. Additionally, a smaller product has less mass than that of a larger product, and in this case is another limiting factor for overall spread width.

A small product with high crush strength will have limited spread width capabilities. While spinner RPM can be increased with little worry of pulverizing the product, a smaller product has less mass than that of a larger product, which limits how far the product will carry in the spread pattern.

A large product with low crush strength will have limited spread width capabilities. While a larger product with more mass will carry farther, spinner RPM must remain lower to keep from pulverizing the soft product, limiting the overall spread width.

A large product with high crush strength has minimal spread width limitations. Spinner RPM can be increased with little worry of pulverizing the product. Additionally, a large product has more mass than that of a smaller product, allowing the product to carry farther, resulting in a wider spread width.

PRODUCT SETUP GUIDELINES

Granule Mesh	Crush Strength	Maximum Spinner RPM	Flotation Machine (Spinner Height 52") Spread Width ft(m)	Post Machine (Spinner Height 72") Spread Width ft(m)
140-200	1	600	60-65(18-20)	70-75(21-23)
	3	650-700	65-70(20-21)	75-80(23-24)
	6	750-800	70-75(21-23)	80-85(24-26)
	8	850-900	75-80(23-24)	85-90(26-27)
220-300	1	600	70-75(21-23)	80-85(24-26)
	3	650-700	75-80(23-24)	85-90(26-27)
	6	750-800	80-85(24-26)	90-95(27-29)
	8	850-900	85-90(26-27)	95-100(29-30)
320-400	1	600	80-85(24-26)	90-95(27-29)
	3	650-700	85-90(26-27)	95-100(29-30)
	6	750-800	90-95(27-29)	100-105(30-32)
	8	850-900	95-100(29-30)	105-110(32-33)
>400	1	600	90-95(27-29)	100-105(30-32)
	3	650-700	95-100(29-30)	105-110(32-33)
	6	750-800	100-105(30-32)	110-115(33-35)
	8	850-900	105-110(32-33)	115-120(35-37)

IMPORTANT!

Always check crush strength prior to selecting spinner speed. Pan testing should ALWAYS be performed on any new or different material to determine actual spread width. Verify granules are not pulverized by looking in the three center vials following a pan test before increasing spinner speed.

CRUSH TESTClick or Scan -
Crush Test Procedure**IMPORTANT!**

Select granules of the most typical size and uniform shape as determined by SGN scale. Crushing strength can significantly increase with particle size.

**Figure 1**

1. Figure 1 - Place individual granule on solid, smooth surface.
2. Place New Leader crush strength tester over granule, open end flush with surface.

Ensure marker is next to handle.

**Figure 2**

3. Figure 2 - With one hand on handle, press tester down until granule breaks.

**Figure 3**

4. Figure 3 - Release handle and note where marker rests on number scale. This is granule crushing strength.

For example, the marker in Figure 3 is between 3 and 4 on the scale. Thus, crushing strength is 3.5.

5. Repeat 10 times and average the values.

SGN SCALE TESTClick or Scan -
SGN Scale Test Procedure

The SGN scale is an instrument designed for simple screen test of fertilizer samples. A small box fitted with five sieves, it directly produces a size histogram of the test sample. From this, the SGN can be estimated.



Figure 4

1. Figure 4 - To determine SGN, place scale on flat surface and open lid.
2. Fill end column with selected product to fill line.
3. Close lid securely.

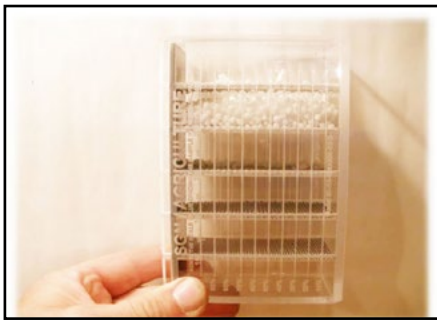

Figure 5

4. Figure 5 - Rotate scale vertical and shake to separate material, usually less than two minutes.
5. When material finishes dispersing, turn scale to starting position.

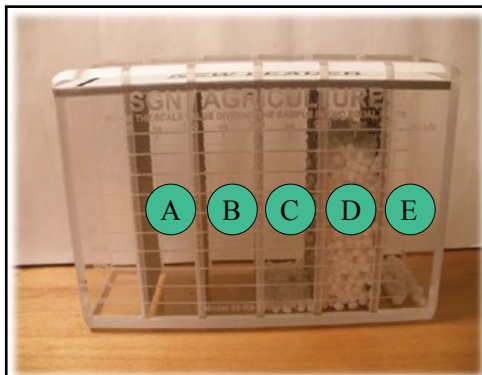

Figure 6

6. Figure 6 - View level of material in each compartment and determine SGN level based on markings.

SPREAD PATTERN TESTING CONTINUED

SGN
Size Grade Number

View each column for percentage

- Column A (120) = 0 material
- Column B (170) = 0 material
- Column C (240) = 5% of 240 equals 12
- Column D (340) = 90% of 340 equals 306
- Column E (400+) = 5% of 400 equals 20
- Total: 12+306+20 = 338 as average SGN

7. Figure 7 - Based on column headings and percent in each field, calculate overall SGN of the sample.

Figure 7

Using the above crush strength example of 3.5 and average SGN size of 338, we can now use the chart to determine our maximum spread width. In this case a maximum spinner speed of 650-700 RPM will produce a spread width of 85' to 100' depending on spinner height.

Granule Mesh	Crush Strength	Maximum Spinner RPM	Flotation Machine (Spinner Height 52") Spread Width ft(m)	Post Machine (Spinner Height 72") Spread Width ft(m)
320-400	1	600	80-85(24-26)	90-95(27-29)
	3	650-700	85-90(26-27)	95-100(29-30)
	6	750-800	90-95(27-29)	100-105(30-32)
	8	850-900	95-100(29-30)	105-110(32-33)

CATCH TEST

Click or Scan -
Catch Test Procedure
John Deere



NOTE: An optional calibration chute (P/N 312688) is available to simplify the catch test process. The calibration chute fits all New Leader spreader models with 30" wide conveyor bottoms. Contact your local New Leader dealer for details.

**WARNING**

To prevent injury, disable the spinners by unplugging the PWM valve before beginning the catch test procedure.

1. Disable the spinners by unplugging the PWM valve.
2. Move the spinner assembly to the 4" (10.2cm) position on the indicator by cranking the handle.
3. Remove the Material Divider back plate, and if available, install calibration chute.
4. Position an end loader or other suitable device beneath the spinners to catch material.
5. Load material into all applicable bins.
6. Prime the conveyor as specified per the controller.
 - If using a calibration chute, run the conveyor just until material reaches the end. Remove any excess material that falls into the catching device.
 - If not using a calibration chute, run the conveyor until the spinner discs are full of material. Remove any excess product from the catching device. Do not remove material from spinner discs.
7. Measure the depth of material on the end of the conveyor to verify the constant number feedgate height information entered into the controller. Adjust feedgate height as necessary.
8. Verify that all other product settings entered into the controller are correct.
9. Select the correct channel/node in the controller for the first bin to be tested. Enter the anticipated weight of product to be dispensed from the conveyor.
10. Start the engine and engage PTO. Allow to run for several minutes to bring hydraulic oil up to operating temperature. Bring engine up to operating RPM.
11. Following the setup wizard on the controller, run the catch test. The conveyor will start dispensing material, and automatically shut off when the estimated amount of product is dispensed.
12. If not using a calibration chute, leave the material on the spinner discs. Weigh the amount of product that the conveyor actually dispensed into the catching device, and note the result.
13. Enter the actual weight of material dispensed into the controller. The controller will then automatically perform the calibration.
14. Repeat Steps 5 - 12 for all other applicable bins, if a MULTAPPLIER or MULTIBIN is equipped.
15. Once satisfactory results have been achieved for all applicable bins, turn the engine off, replace the back plate on the Material Divider, return the spinner assembly to its original position setting, and plug the PWM valve back in.

NOTE: For more information on controller operations and setup, contact your local dealer.

PERFORMING A SPREAD PATTERN TEST

Click or Scan -
Spread Pattern Test Procedure
John Deere



WARNING

Use great caution while working around the spreader. Contact with spinners and other moving parts is very dangerous. Do not adjust while machinery is moving, wear eye protection and avoid discharge from spinners. Do not ride on moving spreader.

It is recommended that spread pattern tests be conducted prior to each spreading season, after any spreader maintenance, and periodically during the spreading season. Spread pattern tests must be performed for each product and application rate.

Spread pattern is affected by many factors. Among the more significant of these are:

- Spinner speed
- Material density
- Material granule size
- Material flow characteristics
- Rate of material delivery
- Point of material delivery on spinner discs
- Angle of the distributor fins on the spinner discs
- Cleanliness of the spinner fins and discs
- Wind and humidity
- Spacing of swaths
- Wear on spinner fins

Since many of these factors will vary for each job, trial and experience must be used to determine the adjustments required to obtain the spread width and spread pattern desired. The following instructions outline the adjustments available and the effect that each will have on the spread pattern.

SPREAD PATTERN TEST KIT

300508 Spread Pattern Test Kit, includes the following:

<u>PART NO.</u>	<u>DESCRIPTION</u>	<u>QTY</u>	<u>PART NO.</u>	<u>DESCRIPTION</u>	<u>QTY</u>
70890	Collection Tray	21	99418	Data Sheets	100
87200	Divider	21	300503	Screw – #6-32 x 3/8	42
300506	Rack – Tube	1	300504	Nut – Lock #6-32	42
300507	Test Tubes	21	70897	Flags	5
300505	Clip – Molded	21	87199	Rope – 120’ marked	1
87332	Funnel	1	87201	Stakes	2
58897	Scale – Density	1			

SPINNERS

NOTICE! Spinner discs and fins must be kept clean and polished. Even a small build-up on a spinner fin can significantly affect the spread pattern. Rusty, rough, bent or worn fins will produce poor spread patterns.

Spinner speed is adjustable from approximately 400 to 900 RPM. This is accomplished by changing the settings in the controller. Proper spinner speed adjustment is very important in obtaining optimal spread patterns. The best spinner speed to use will depend entirely on the material being spread, and must be determined by testing.

A major factor of maximum pattern width is particle size. Pattern width may vary anywhere from 25 feet (7.6 m) for very finely ground dry lime up to 120 feet (37 m) or more for extremely large fertilizer pellets.

For every material there is a critical spinner speed. In other words, there is a speed which will result in the maximum obtainable spread width. Going beyond this speed will not increase spread width, but will result in a poor pattern.

Too high of a spinner speed could result in a heavy deposit behind the truck due to break-down of material. This upper speed limit will be quite low for finely powdered material, and can be quite high for extremely coarse materials. In general, this critical speed will fall somewhere between 600 and 800 RPM for typical materials.

It is recommended that a spread pattern test be performed for each product and application rate you handle. Once initial testing is completed, testing should be repeated at the beginning of every season, or any time maintenance is performed on any component affecting spread patterns.

SPREADER PREPARATION

The spreader to be tested shall be in good mechanical condition and properly adjusted according to the Operation and Maintenance sections in this Manual.

All damaged and worn parts must be replaced. Spinner discs and fins must be free of any material build-up, rust or paint.

Fill the hopper with the material to be spread. Run the material out to the end of the conveyor.

Set the feedgate to deliver the required rate per acre. Make sure the feedgate is level and the indicator reflects the actual gate opening measured by standing a tape measure vertically in the fertilizer.

NOTE: Do not match slope of endgate when making this measurement.

Adjust the spinner assembly by turning the crank or, if an actuator is installed, change the setting in the controller. To begin testing, position the spinner according to the chart below.

NOTE: This chart is to be used as a reference only to begin testing.

MATERIAL	DENSITY lbs/cu ft (kg/cu m)	SPINNER ASSEMBLY POSITION in (cm)
Lime	80-100 (1281-1601)	0 - 1 (0 - 2.5)
Fertilizer	65 (1040)	3.5 - 3.75 (9 - 9.5)
Urea, Light Rate - 50-200 lb/acre (56-224 kg/hectare)	48 (769)	3.5 - 3.75 (9 - 9.5)
Urea, Heavy Rate - >200 lb/acre (>224 kg/hectare)		2.0 - 2.5 (5 - 6.5)
Mixed Product, MultApplier	65 (1040)	3.75 (9.5)

TEST PROCEDURE

The area selected for testing, measuring 120 feet x 400 feet (37 m x 122 m), should have a slope of less than two degrees.

Insert a plastic grid into each of the 21 collection trays. Position the 21 collection trays on six-foot (6') (182.88cm) centers with the longest dimension of the tray parallel to the direction of travel. (Figure 1A)

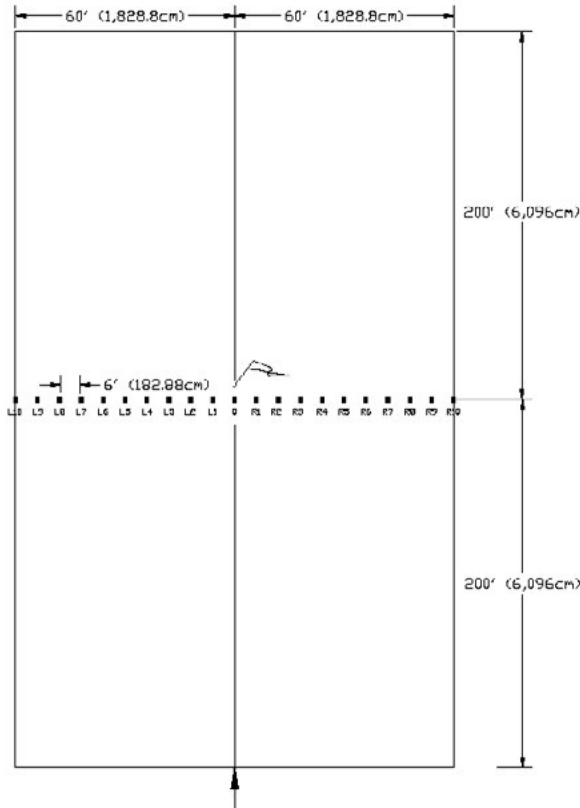

DIRECTION OF TRAVEL
COURSE SET UP FOR PATTERN TEST

Figure 1A – Tray Positions

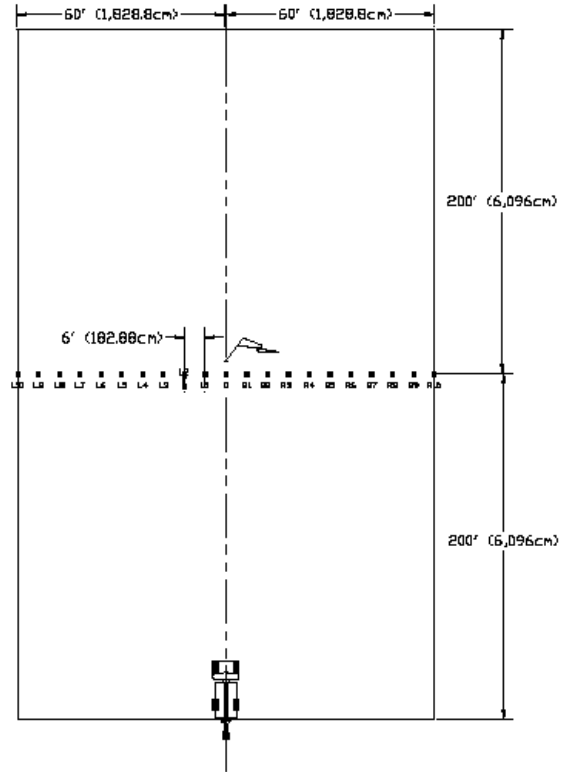

DIRECTION OF TRAVEL
COURSE SET UP FOR PATTERN TEST

Figure 1B – Spreader Position

All testing should be done when the wind velocity is less than 5 MPH (8.05 km). If wind is present, testing must be done with spreader traveling parallel (within ± 15 degrees) to the wind direction.

Do not allow loaded spreader to sit for more than four hours prior to testing.

Prior to driving the spreader through the test course, it should be driven at least 450 feet (137 m) at spreader test speeds.

Spreader must be driven over the collection trays in ONLY ONE DIRECTION.

Position spreader at the beginning of the course so that vehicle will straddle center collection tray. (Figure 1B) Set gate opening based on desired rate/acre according to theoretical application charts supplied with each unit.

Drive spreader completely through course at normal operating speeds.

DATA RECORDING

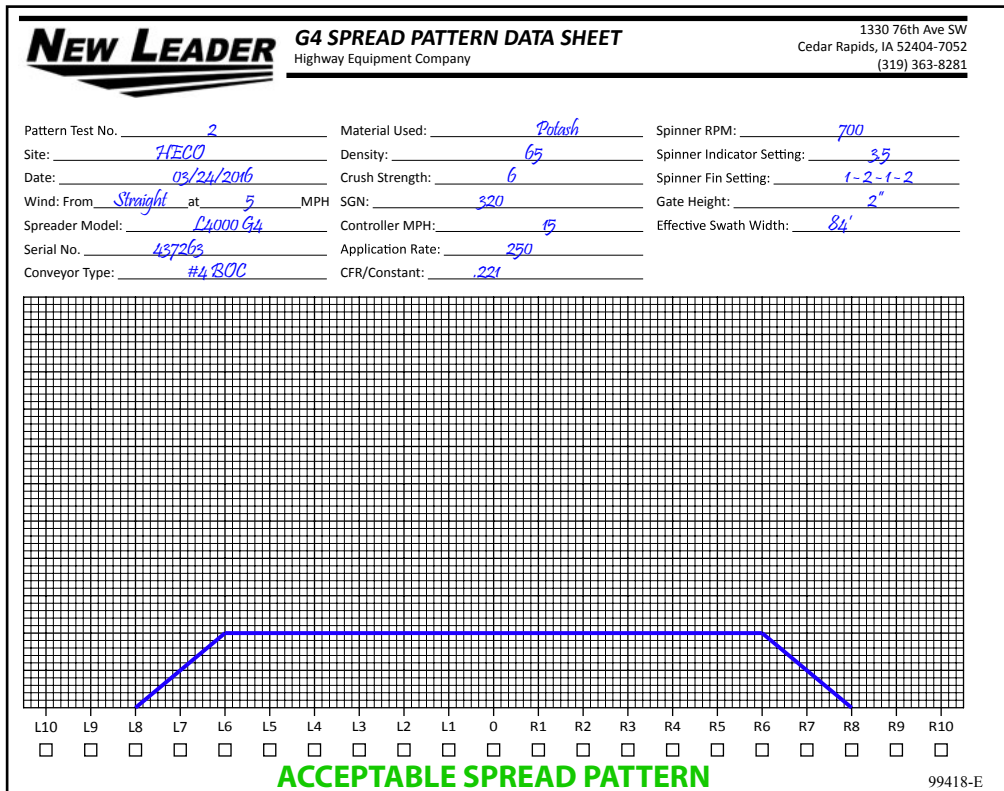
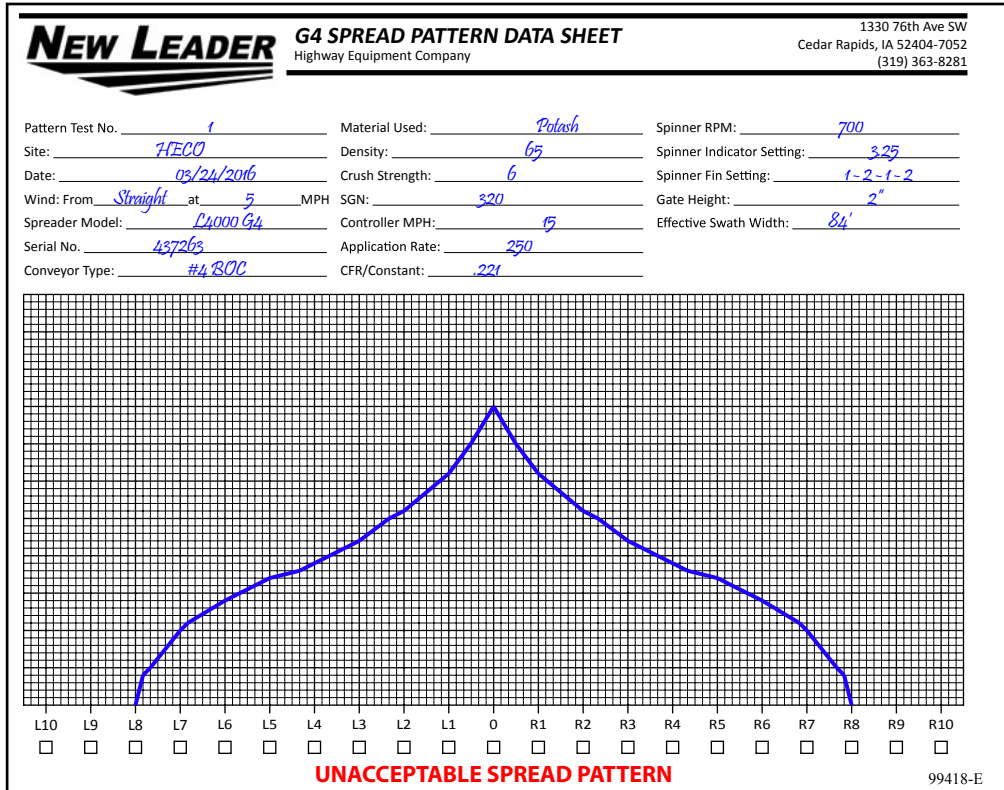

Figure 2 – Spread Pattern Data Sheet Example

SPREAD PATTERN

Using the data sheets supplied with the kit, document all spreader adjustments required.

Using the funnel, transfer the contents of each collection tray into its corresponding test tube beginning at one end of the trays and working towards the opposite end.

Record the volume in each test tube in the box on the data sheet under the corresponding tray position. (Figure 2) NOTE: It is highly recommended that ONLY ONE ADJUSTMENT be made between test samples taken. If more than one adjustment is made, it will be difficult to determine which adjustment was responsible for the change in pattern shape.

Once a desirable pattern is obtained (Figure 5), optimum driving centers can be determined. To determine optimum driving centers (effective swath width), locate the points on both the left and right side of the pattern where the amount of material applied is half the amount at the center of the pattern. The distance between these two points represents the driving centers to be used.

When blended fertilizers are being applied, a visual inspection of the samples should be made to determine whether the blend within the effective swath width is consistent with the desired blend. If the blend is not consistent, a narrower overall swath width should be used and a new optimum driving center (effective swath width) should be determined.

Once the effective swath width has been established, a change in the controller may be required.

DRIVING METHODS

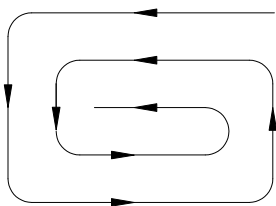

Figure 3 – Perimeter Method

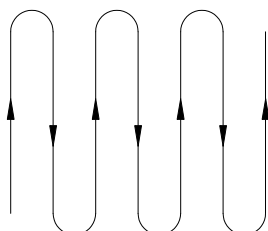

Figure 4 – Switch Back Method

The perimeter (Figure 3) and switch back (Figure 4) driving methods are both acceptable. NOTE: Utilizing the switch back method amplifies non-symmetrical patterns by blending right side on right and left side on left. The perimeter method compensates for non-symmetrical patterns by blending the right side of the pattern with the left side of the adjacent pattern or vice versa.

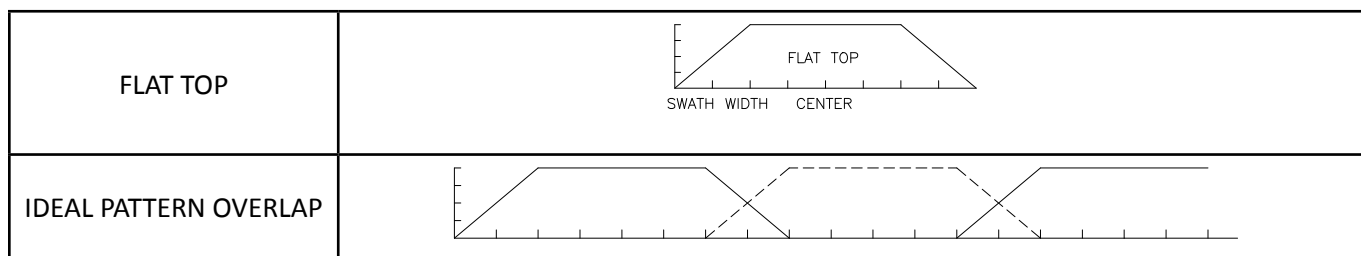
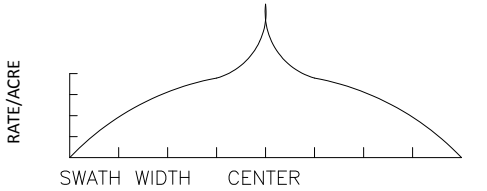
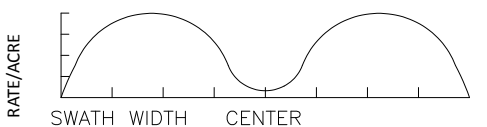
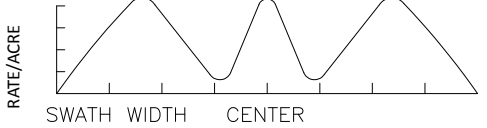
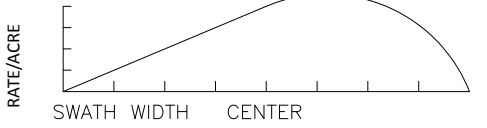

Figure 5 – Ideal Pattern

TROUBLESHOOTING

Problem	Pattern	Recommended Adjustments
Heavy Directly Behind the Vehicle		<ol style="list-style-type: none"> 1. Move the spinner forward (toward the conveyor). 2. Decrease spinner RPM. 3. Check spinner fin quality. 4. Move one or two spinner fins to a lower numbered hole.
Light Directly Behind the Vehicle		<ol style="list-style-type: none"> 1. Move the spinner rearward (away from conveyor). 2. Increase spinner RPM. 3. Check spinner fin quality. 4. Move one of two spinner fins to a higher numbered hole.
Light Outside Vehicle's Tire Tracks		<ol style="list-style-type: none"> 1. Check spinner fin quality. 2. Decrease spinner RPM. 3. Move one or two spinner fins to a lower numbered hole.
Pattern Off Center		<ol style="list-style-type: none"> 1. Check to see feedgate is level and free of caked material. 2. Make sure hillside divider is mounted squarely and centered. 3. Check to be sure spinner assembly is mounted squarely and centered. 4. Make sure material divider is mounted squarely and centered. 5. Testing should be done parallel to wind.

SPREAD PATTERN