



MODEL SA-6C

UNIT SERIAL NUMBER _____

MANUAL NUMBER: 96875-I

EFFECTIVE 12/2022



1330 76TH AVE SW
CEDAR RAPIDS, IA 52404-7052
PHONE (800) 363-1771 | FAX (319) 286-3350
www.newleader.com

Copyright 2021 New Leader Manufacturing

Interactive Features	4
Warranty	6
Preface	9
Safety	10
Important Safety Information	10
Safety Alert Symbols	10
General Safety Rules	11
Safety Decals.....	21
Safety Decal Maintenance.....	21
Safety Decal Installation	21
Installation Instructions	25
Pump Installation.....	25
Transmission Pto Drive.....	26
Hydraulic Pump Driveshaft.....	26
Electric Clutch V-Belt Drive.....	27
Cab Control Valve	27
Tailgate Filler Panels	28
Mounting Of Spreader.....	29
Spinner Assembly.....	30
Leveling Mechanism	31
Hydraulic Hose Installation.....	32
Reusable Non-Skive Type Ends.....	33
Hydraulic Hose Maintenance	34
Hydraulic Hose Installation Guide	35
Electrical Connections	36
Lights.....	36
Filling The Hydraulic System	36
Operations and Maintenance.....	39
General Description	39
Dimensions & Capacities	40
Automatic Dual Control System.....	44
Hydraulic System.....	45
Pressure Setting.....	45
Hydraulic System.....	48
Gearcase Lubricant	48
Grease Gun Lubricant.....	49
Initial Start-Up	41
General Operating Procedures	42
Lubrication and Maintenance.....	46
Preventative Maintenance Pays!	46
Hydraulic System.....	46
Service Schedule	46
Lubrication of Bearings.....	47
Fasteners.....	47
Clean-Up.....	47
Lubricant and Hydraulic Oil Specifications.....	48
Lubrication Chart.....	50
Troubleshooting.....	51
Hydraulic Schematic.....	52
Standard Torques.....	53

Parts	57
Instructions for Ordering Parts	57
Tailgate Baffles.....	58
Trough - Direct Drive.....	59
Trough - Gearcase Drive	61
Spinner	63
Mounting.....	65
Mounting - Quick Disconnect	66
Gearcase	67
Hydraulic Motor - Auger.....	69
Hydraulic Motor - Spinner	70
Hydraulic System	71
Pump Kit with Electric Clutch	73
Hydraulic Pump (with Electric Clutch).....	74
Hydraulic Pump	75
Mounting Kit - Pump (Transmission PTO)	76
Pedestal Mount Kit.....	77
Decals.....	78



NOTE:

This manual incorporates several interactive features to provide supplemental information and ease of navigation. The information below is to aid in the identification and use of these features.

Hyperlinks

Hyperlinks provide direct access to a specific destination when clicked. The entire Table of Contents of this manual is hyperlinked to provide quick access to all sections of this manual when viewing the electronic version.

Hyperlinks within the content are denoted by **blue, bold underlined text**. Electronic format viewers can click these links for direct access to New Leader online features. Internet access is required.

This page is intentionally left blank.

Insert Current Hi-Way Warranty

PLEASE ! ALWAYS THINK SAFETY FIRST !!

The purpose of this manual is to familiarize the person (or persons) using this unit with the information necessary to properly install, operate, and maintain this system. The safety instructions indicated by the safety alert symbol in the following pages supersede the general safety rules. These instructions cannot replace the following: the fundamental knowledge that must be possessed by the installer or operator, the knowledge of a qualified person, or the clear thinking necessary to install and operate this equipment. Since the life of any machine depends largely upon the care it is given, we require that this manual be read thoroughly and referred to frequently. If for any reason you do not understand the instructions, please call your authorized dealer or our Product Sales and Support Department at 1-888-363-8006.

It has been our experience that by following these installation instructions, and by observing the operation of the spreader, you will have sufficient understanding of the machine enabling you to troubleshoot and correct all normal problems that you may encounter. Again, we urge you to call your authorized dealer or our Product Sales and Support Department if you find the unit is not operating properly, or if you are having trouble with repairs, installation, or removal of this unit.

We urge you to protect your investment by using genuine NLM parts and our authorized dealers for all work other than routine care and adjustments.

New Leader Manufacturing reserves the right to make alterations or modifications to this equipment at any time. The manufacturer shall not be obligated to make such changes to machines already in the field.

This Safety Section should be read thoroughly and referred to frequently.

ACCIDENTS HURT !!!

ACCIDENTS COST !!!

ACCIDENTS CAN BE AVOIDED !!!



Important Safety Information

▲ WARNING

Before using this equipment, read, understand and follow all instructions in the Operator's Manual provided with this equipment. If the user and/or assistants cannot read or understand the warnings and instructions, the employer of the user and/or assistants must provide adequate and necessary training to ensure proper operation and compliance with all safety procedures pertaining to this equipment. If Operator's Manual has been lost, visit www.newleader.com or call your authorized dealer or our Product Sales & Support Department at (800) 363-1771 for replacements. Serious injury or death can result from the failure to read, understand, and follow instructions provided in this manual.

Figure 1.1 - The need for safety cannot be stressed strongly enough in this manual. At New Leader Manufacturing, we urge you to make safety your top priority when operating any equipment. We firmly advise that anyone allowed to operate this machine carefully read, learn and understand all messages and information in this manual and on machine's safety decals before operating machine, as well as familiarize themselves with the location and function of all machine controls.

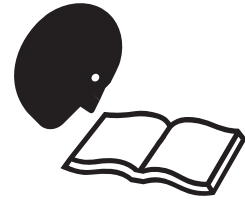

Figure 1.1

The following guidelines are intended to cover general usage and to assist you in avoiding accidents. There will be times when you will run into situations that are not covered in this section. At those times the best standard to use is common sense. If, at any time, you have a question concerning these guidelines, please call your authorized dealer or our Product Sales & Support Department at (800) 363-1771.

Safety Alert Symbols



Take note! This safety alert symbol found throughout this manual is used to call your attention to instructions involving your personal safety and that of others. Failure to follow these instructions can result in injury or death.

In this manual and on the safety signs placed on the unit, the words "DANGER," "WARNING," "CAUTION," and "NOTICE" are used to indicate the following:



DANGER indicates a hazardous situation which, if not avoided, will result in death or serious injury.



WARNING indicates a hazardous situation which, if not avoided, could result in death or serious injury.



CAUTION indicates a hazardous situation which, if not avoided, could result in minor or moderate injury.



NOTICE is used to address practices not related to physical injury.

NOTE:

Provides additional information to simplify a procedure or clarify a process.

General Safety Rules

Operations

PREPARE FOR EMERGENCIES

Figure 1.2 - Be prepared if a fire starts. Keep a fully charged fire extinguisher and first aid kit in accessible place on the vehicle at all times.

Fire extinguisher must be Type ABC or Type BC.

Keep emergency numbers for doctors, ambulance service, hospital and fire department available at all times.

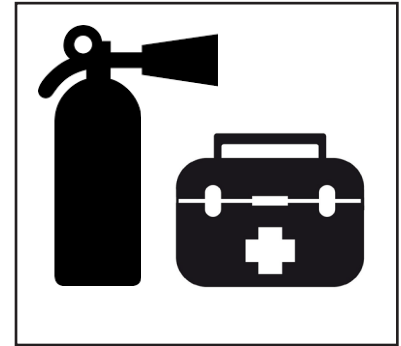

Figure 1.2

INSPECT HARDWARE BEFORE USE

Figure 1.3 - Inspect all bolts, screws, fasteners, keys, chain drives, body mounts and other attachments periodically. Immediately replace any missing or damaged parts with NLM specified parts.

Inspect spinner fins, spinner frame mounting and spinner fin hardware daily. Look for missing or loose fasteners, wear and cracks. Replace immediately with NLM specified parts.

Tighten all bolts, nuts and screws to specified torques. Refer to "Standard Torques" in Maintenance section of this manual.

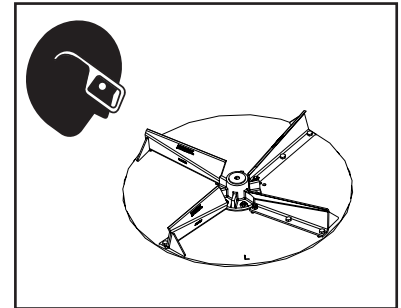

Figure 1.3

HANDLE FLAMMABLE MATERIALS SAFELY

Figure 1.4 - Handle fuel and hydraulic oil with care. They are highly flammable.

Exposure to toxic fluids or fumes may occur during the normal operation of this system. Before attempting to fill, use, or service this system, read Safety Data Sheets (SDS) to know the specific hazards of the fluids you are using. Always use proper Personal Protective Equipment when attempting to fill, use, or service this system.

Always stop engine before refueling machine or filling hydraulic reservoir.

Never smoke while adding fuel or oil to machine. Add fluids in a safe place away from open flame and sparks.

Do not allow overflow. Clean up spilled fuel and oil immediately.

Always have a multipurpose dry chemical fire extinguisher filled and available during machine operation and when adding fuel. Know how to use it.



Figure 1.4

General Safety Rules

Operations

HANDLE HAZARDOUS MATERIALS SAFELY

Figure 1.5 - Materials to spread can be dangerous.

Improper selection, application, use or handling may be a hazard to persons, animals, plants, crops or other property.

A Safety Data Sheet (SDS) provides specific details on chemical products: physical and health hazards, safety procedures and emergency response techniques.

Check all SDS's before starting any job using a hazardous material. Follow all instructions and precautions given by the material manufacturer.



Figure 1.5

WORK IN WELL-VENTILATED AREAS

▲ WARNING	Never run machine engine inside a building unless adequate ventilation is provided to safely and properly remove exhaust fumes. Failure to comply with this requirement could result in death or serious injury.
------------------	--

Figure 1.6 - Always work in a properly ventilated area.

Engine exhaust fumes can cause sickness or death. If it is necessary to run an engine in an enclosed area, use proper equipment to safely remove exhaust fumes from the working area.

Open building doors and get fresh air into the working area whenever possible.

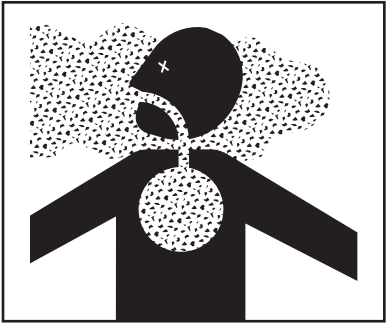

Figure 1.6

PROTECT AGAINST NOISE

Figure 1.7 - Long periods of exposure to high decibels or loud noise can cause hearing impairment or loss.

Wear proper hearing protection such as earmuffs or earplugs during periods of exposure to high decibels or loud noise.

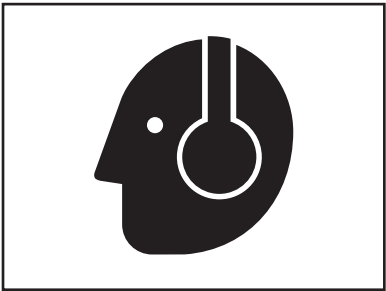

Figure 1.7

General Safety Rules

Operations

AVOID MOVING PART HAZARDS

Figure 1.8 - Entanglement in rotating drive lines or moving parts will cause serious injury or death.

Stay clear of all moving parts, such as shafts, couplings and universal joints.

Make sure all personnel are clear of machine before starting.



Figure 1.8

Figure 1.9 - Do not operate machine without all guards and shields closed and secured.

Disconnect and lock out power source before removing guards.

Disconnect and lock out power source before adjusting or servicing.

Keep hands, feet, hair and clothing away from moving parts.

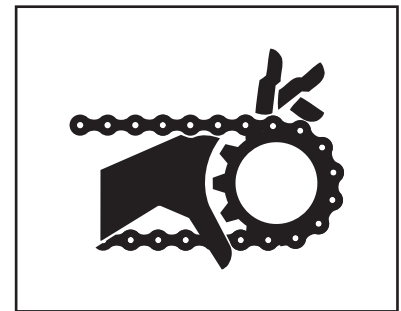

Figure 1.9

Figure 1.10 - Keep away from spinners while they are turning.

Rocks, scrap metal and other material can be thrown from the spinners violently. Stay away from discharge area.

Stop machine before servicing or adjusting. Wear eye protection.

Make sure discharge area is clear before spreading.

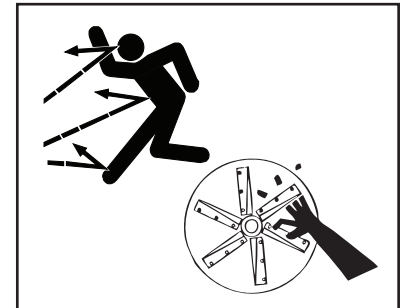

Figure 1.10

Figure 1.11 - Stay out of spreader.

If necessary to enter the spreader, return to shop, empty body, turn off all power, engage brakes, shut down engine and remove keys before entering.

Tag all controls to prohibit operation. Tags should be placed, and removed, by the person working in the body.

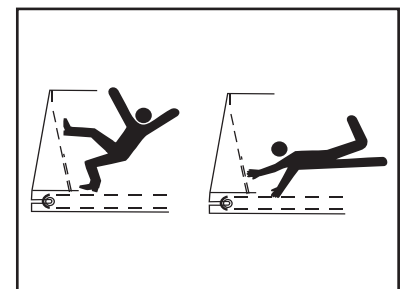

Figure 1.11

General Safety Rules

Operations

DO NOT CLIMB OR STAND ON MACHINE

Figure 1.12 - Never allow any personnel to ride in or on the machine.

Use inspection ladder or portable ladder to view the unit. Use caution when getting on and off the ladder, especially in wet, icy, snowy or muddy conditions. Clean mud, snow and ice from steps and footwear.

Always maintain three-point contact with steps, ladders and handholds. Face the machine when mounting and dismounting inspection ladder. Do not jump off machine.



Figure 1.12

OPERATE MACHINE SAFELY

Always walk around and visually inspect machine before using. Check the immediate vicinity of machine for people and obstructions. Ensure adequate visibility.

Avoid distractions such as reading, eating or operating personal electronics while operating machine. Never operate the machine under the influence of alcohol, drugs or while otherwise impaired.

Always come to a complete stop before reversing. Be sure that all personnel are clear of machine path. Turn around and look directly for best visibility. Ensure all rear view mirrors are properly installed and adjusted. Use a signal person when backing if view is obstructed or when in close quarters.

Always disengage hydraulics before shutting down engine. DO NOT start engine with hydraulics engaged.



General Safety Rules

Transportation & Handling

TRAVELING & TRANSPORTING ON PUBLIC ROADS

Always walk around and visually inspect the machine before traveling on public roads. Check for damage and/or faulty components that can fail and create a hazard or unsafe condition. Make sure all machine systems operate properly, including but not limited to: headlights, tail and brake lights, hazard warning lights, turn indicators, parking brake, horn and rear view mirrors. Repair or replace any component that is not in proper working order.

Never drive machine at a speed that causes it to bounce or cause loss of control.

Obey all traffic safety laws and regulations. Operate the machine with hazard warning lights on, unless prohibited by law. It is the operator's responsibility to activate and use road lights properly while traveling on public roads.

Cover all loads that may spill or blow away. Environmental damage may result. Do not spread dusty materials where dust may create pollution, visibility issues or interfere with traffic on public roads.

When transporting equipment or machine on a trailer, ensure it is properly secured. Be sure that SMV signs on equipment or machine are covered while in transport on a trailer.

Be aware of overhead structures and power lines. Make sure machine can safely pass under. Refer to "Dimensions & Capacities" pages in the Operations section of this manual.

NAVIGATING ROUGH & UNEVEN TERRAIN

Figure 2.1 - Turn slowly and be careful when traveling on rough surfaces and side slopes. Avoid holes, ditches and obstructions that may cause machine to roll over, especially with a loaded spreader.

Never drive near the edge of a gully or steep embankment.

Load may shift, causing vehicle to tip.

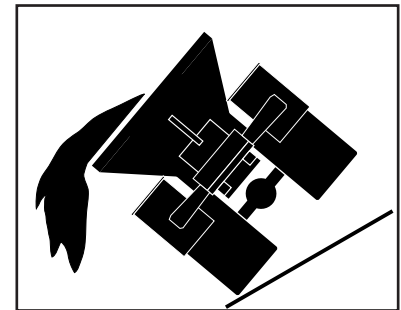

Figure 2.1

General Safety Rules

Maintenance

READ AND UNDERSTAND MAINTENANCE PROCEDURES

Figure 3.1 - Read the maintenance and safety instructions and understand them before performing any maintenance procedure.

Never perform any maintenance procedure or repair if the instructions and safety procedures are not fully understood. Only trained and qualified personnel should perform any maintenance procedure or repair.

Never modify any equipment or add attachments not approved by New Leader Manufacturing.

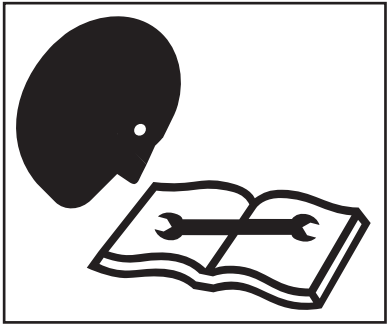

Figure 3.1

DO NOT SERVICE OR ADJUST MACHINE WHILE IN MOTION

Figure 3.2 - Never lubricate, service or adjust the machine or any of its components while they are moving.

Never wear loose clothing or jewelry when working near machine tools or moving parts.

Remove rings and other jewelry to prevent electrical shorts and other personal injury when in contact with machine tools or moving parts.

Close and secure all guards removed for service. Check all screws, bolts, nuts and fasteners for proper torques before operating machine.

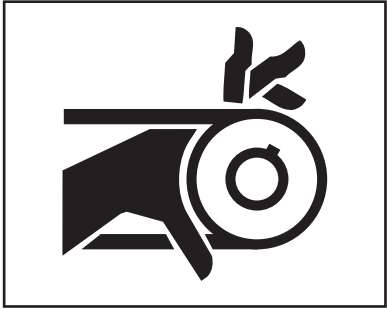

Figure 3.2

WEAR PROPER PROTECTIVE EQUIPMENT

Figure 3.3 - Wear close-fitting clothing and proper safety equipment for the job.

Always wear eye protection when working on or around the machine.

Wear a suitable hearing protection device such as earmuffs or earplugs to protect against high decibels or loud noises.

Prolonged exposure to high decibels or loud noise can cause hearing impairment or loss of hearing.

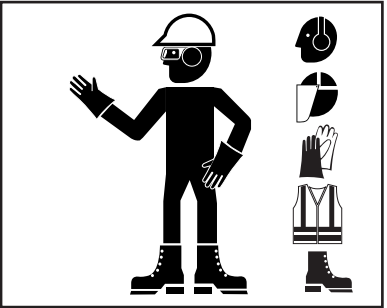

Figure 3.3

Wear protective gloves to protect hands from cuts, abrasions and minor burns.

General Safety Rules

Maintenance

HANDLE FLAMMABLE SOLVENTS SAFELY

Figure 3.4 - Never use diesel fuel, kerosene, gasoline or any flammable solvents for cleaning.

Exposure to toxic fluids or fumes may occur during the normal operation of this system. Before attempting to fill, use, or service this system, read Safety Data Sheets (SDS) to know the specific hazards of the fluids you are using. Always use proper Personal Protective Equipment when attempting to fill, use, or service this system.

Perform work using flammable fluids and solvents in a safe place away from open flame and sparks. Do not smoke.

Do not weld, grind or flame cut on any tank containing oil, fuel, fumes or any other flammable material, or any container that contents or previous contents are unknown. Move all flammable materials and containers away from work area.

Clean up spilled fuel and oil immediately.

Always have a multipurpose dry chemical fire extinguisher filled and available. Know how to use it.



Figure 3.4

USE PROPER LIFTING EQUIPMENT

Figure 3.5 - Use only lifting devices that meet or exceed OSHA standard 1910.184 or ASME B30.20-2013.

Never lift equipment over people.

Never lift a loaded unit. Never lift unit with any loose objects or persons in the body. Loads may shift or fall if improperly supported, causing death, serious injury or machine damage.

Before unfastening heavy parts or assemblies, support with adequate hoist or other device to prevent falling, tipping, swinging or any other movement that may cause injury or damage.



Figure 3.5

USE PROPER TOOLS FOR THE JOB

Figure 3.6 - Use of improper tools (such as a screwdriver instead of a pry bar, pliers instead of a wrench, a wrench instead of a hammer) can cause serious injuries or machine damage.

Use power tools only to loosen threaded parts and fasteners. Using power tools to tighten may cause over-tightening and component damage.

Use only service parts meeting New Leader specifications.

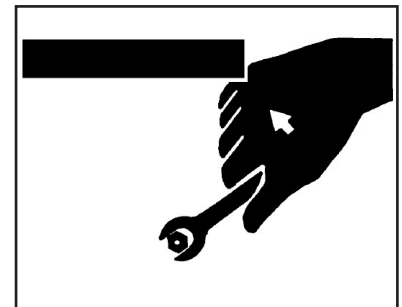

Figure 3.6



General Safety Rules

Maintenance

HIGH PRESSURE FLUID HAZARDS

Figure 3.7 - Escaping fluid under pressure can penetrate the skin causing serious injury.

Always stop machine, allow to cool and relieve pressure before servicing hydraulic system. Never open hydraulic lines under pressure. Make sure all connections are tight and all hoses are in good condition before pressurizing system.

Always use a piece of cardboard or wood to search for leaks instead of hand. Wear impervious gloves and eye protection when servicing system.

Seek medical attention immediately if fluid penetrates your skin. Gangrene may result if wound is left untreated.



Figure 3.7

AVOID HEATING NEAR HIGH PRESSURE FLUID LINES

Figure 3.8 - Flammable spray can be generated by heating near pressurized fluid lines, resulting in burns to yourself and bystanders.

Do not heat by welding, soldering or using a torch near pressurized fluid lines or other flammable materials.

Pressure lines can suddenly burst when heat goes beyond the immediate flame area.

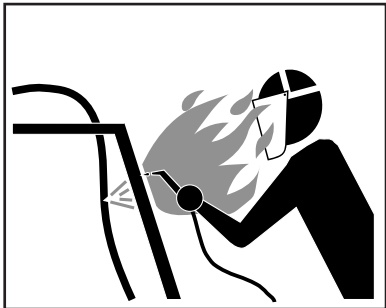

Figure 3.8

AVOID TOXIC FUMES & DUST

Figure 3.9 - Hazardous fumes can be generated when paint is heated from welding, soldering or using a torch.

Remove paint before heating:

- Remove a minimum of 4 in (100 mm) from area to be affected by heating. If paint cannot be removed, wear an approved respirator while heating or welding.
- Avoid breathing dust from sanding or grinding on paint.
- If a solvent or paint stripper is used, wash stripper away with soap and water before heating or welding. Remove solvent or paint stripper containers and other flammable material from area. Allow fumes to disperse for at least 15 minutes before heating or welding.

Do not use chlorinated solvents in areas where welding will take place.

Perform all work in a well-ventilated area that will carry all toxic fumes and dust away.



Figure 3.9



General Safety Rules

Maintenance

CLEAN MACHINE OF HAZARDOUS CHEMICALS

CAUTION

During application of hazardous chemicals, residue can build up on the inside or outside of the vehicle. Clean vehicle according to use instructions of hazardous chemical. Failure to comply with this requirement may result in minor or moderate injury.

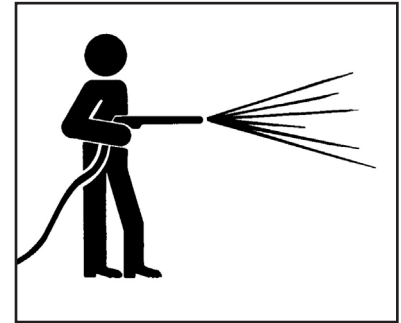

Figure 3.10

Figure 3.10 - When exposed to hazardous chemicals, clean exterior and interior of vehicle daily to keep free of the accumulation of visible dirt and contamination.

1. Clean operator's station to maintain unobstructed visibility of all windows and mirrors, and safe operation of all controls.

NOTICE

Directing pressurized water at electronic/ electrical components, bearings and hydraulic seals or other sensitive parts and components may cause product malfunctions. Reduce pressure and spray at 45 to 90 degree angles.

2. Wash entire exterior of vehicle.
3. Dispose of any wash water with hazardous concentrations of active or non-active ingredients according to published regulations or directives.

HANDLE BATTERIES SAFELY

WARNING

Sulfuric acid in battery electrolyte is poisonous. It can burn skin, eat holes in clothing, and cause blindness if it contacts eyes. Keep sparks and flame away from batteries. Wear proper safety equipment. Failure to comply with this requirement could result in death or serious injury.

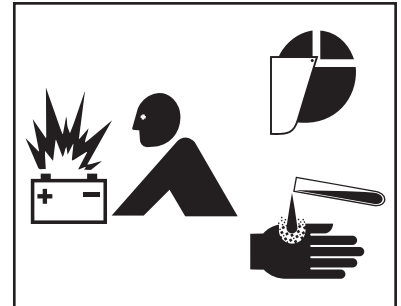

Figure 3.11

Figure 3.11 - Lead acid batteries generate flammable and explosive gases. Keep sparks and flame away from batteries. Do not smoke.

If acid contacts eyes, skin or clothing, flush with water immediately. Seek immediate medical attention if acid contacts eyes.

PROPER TIRE MAINTENANCE

Figure 3.12 - Never weld on a wheel or rim that has a tire on it.

Never attempt to mount or remove a tire unless using the proper equipment, tire safety cage, instructions, training, and you are qualified to perform the work safely. Failure to follow the correct procedures when mounting a tire on a wheel or rim can cause an explosion and serious injury.

Tire service procedures must be performed by trained and qualified personnel.



Figure 3.12

General Safety Rules

Storage

PARK VEHICLE SAFELY

Figure 4.1 - When leaving the vehicle unattended for any reason, be sure to:

- Shut down PTO.
- Shut off vehicle's engine, and unit's engine if applicable.
- Place vehicle transmission in "Neutral" or "Park".
- Set parking brake firmly.
- Remove ignition key and take it with you.
- Block wheels.

These actions are recommended to avoid unauthorized use, runaway, vandalism, theft and unexpected operation during startup.

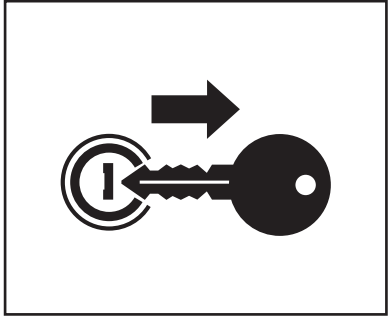

Figure 4.1

SUPPORT MACHINE PROPERLY

Figure 4.2 - When machine is removed from vehicle, always store on adequate supports on a firm level surface. Improper supporting or storage of spreader may cause machine to fall, resulting in serious injury or death.

Never use lifting device to free machine from a chassis, storage stands or frozen ground, or to lift the chassis in any way. Shock loading is prohibited and sudden accelerations must be avoided. Lifting in such a manner could result in injury or machine damage.



Figure 4.2

DISPOSE OF WASTE PROPERLY

Figure 4.3 - Improper disposal of waste can threaten the environment and ecology. Potentially harmful waste used with equipment include items such as fuel, oil, filters and batteries.

Use leakproof containers when draining fluids. Do not use food or beverage containers that may mislead someone into drinking from them. Do not pour waste onto the ground, down a drain, or into any water source.

Comply with all OSHA, local, City, State, Province, Country and jurisdiction regulations, ordinances and standards, related to your particular work area and environment. Inquire on proper disposal methods from your local environmental or recycling center, or from your local dealer.

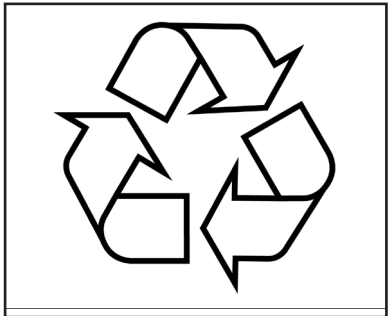

Figure 4.3

Safety Decal Maintenance

Keep safety decals and signs clean and legible at all times.

Replace safety decals and signs that are missing or have become illegible.

Replaced parts that displayed a safety sign should also display the current sign.

Safety decals or signs are available from your dealer's Parts Department or from New Leader Manufacturing by calling (800) 363-1771.

Safety Decal Installation

Clean Surface

Wash the installation surface with a synthetic, free-rinsing detergent. Avoid washing the surface with a soap containing creams or lotion. Allow to dry.

Position Safety Decal

Decide on the exact position before application. Application marks may be made on the top or side edge of the substrate with a lead pencil, marking pen, or small pieces of masking tape. NOTE: Do not use chalk line, china marker, or grease pencil. Safety decals will not adhere to these.

Remove the Liner

A small bend at the corner or edge will cause the liner to separate from the decal. Pull the liner away in a continuous motion at a 180-degree angle. If the liner is scored, bend at score and remove.

Apply Safety Decal

Tack decal in place with thumb pressure in upper corners. Using firm initial squeegee pressure, begin at the center of the decal and work outward in all directions with overlapping strokes. NOTE: Keep squeegee blade even—nicked edges will leave application bubbles. Pull up tack points before squeegeeing over them to avoid wrinkles.

Remove Pre-mask

If safety decal has a pre-mask cover remove it at this time by pulling it away from the decal at a 180 degree angle. NOTE: It is important that the pre-mask covering is removed before the decal is exposed to sunlight to avoid the pre-mask from permanently adhering to the decal.

Remove Air Pockets

Inspect the decal in the flat areas for bubbles. To eliminate the bubbles, puncture the decal at one end of the bubble with a pin (never a razor blade) and press out entrapped air with thumb moving toward the puncture.

Re-Squeegee All Edges



 **DANGER**

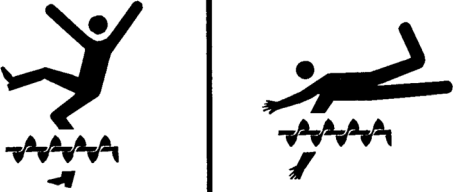

MOVING PART HAZARD
To prevent death or serious injury:

- Stay out of box while auger is running.
- Disconnect and lockout power source before adjusting or servicing.
- Do not ride on machine.

55997-B

 **DANGER**



FLYING MATERIAL & ROTATING SPINNER HAZARD
To prevent death or serious injury:

- Wear eye protection.
- Stop machine before servicing or adjusting.
- Keep bystanders at least 60 feet away.

388-C

 **CAUTION**

HAZARDOUS MATERIALS
To avoid injury or machine damage:

- Materials to be spread can be dangerous.
- Improper selection, application, use or handling may be a hazard to persons, animals, crops or other property.
- Follow instructions and precautions given by the material manufacturer.

321-C

 **CAUTION**

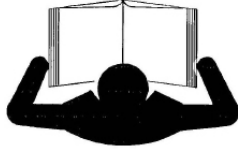

TO AVOID INJURY OR MACHINE DAMAGE:

- Do not operate or work on this machine without reading and understanding the operators manual.
- Keep hands, feet, hair and clothing away from moving parts.
- Do not allow riders on machine.
- Avoid unsafe operation or maintenance.
- Disengage power takeoff and shut off engine before removing guards, servicing or unclogging machine.
- Keep unauthorized people away from machine.
- Keep all guards in place when machine is in use.
- If manual is missing, contact dealer for replacement.

150034-C

 **WARNING**

MOVING PART HAZARD
To prevent death or serious injury:

- Close and secure guards before starting.
- Do not stand or climb on machine.
- Disconnect and lockout power source before adjusting or servicing.
- Keep hands, feet and hair away from moving parts.

55631-C

INSTALLATION

Due to the variations in type and model of trucks, dump bodies and PTO assemblies, no one set of instructions will be applicable to all units. The following is offered as a guide for laying out an individual unit. Considerable latitude is permitted in mounting of parts. The mounting kits contain sufficient parts to allow mounting on most any type of truck. Read the material in this manual carefully before attempting installation.

Recommended sequence of installation is as follows:

1. Mounting of pump and pump drive.
2. Installation of cab controls.
3. Mounting of spreader.
4. Installation of hydraulic hose and electrical wiring.
5. Filling hydraulic reservoir and lubrication.
6. Checking for leaks and functioning.

Pump Installation

The hydraulic pump system must be capable of delivering 20-25 GPM at the desired engine operating speed and be rated for 1500 PSI operation.

How Will the Hydraulic Pump be Driven?

The answer to this question will depend upon the means to drive the pump that exists on your particular unit. One of the following pumps should have been supplied:

PUMP DRIVE	PART NUMBER
Electric Clutch V-Belt Drive	34569
Transmission PTO	24516

Except for the Electric Clutch V-Belt Drive arrangement, which is based on driving pump at engine speed (3000 RPM expected) the above pump selections are based on expected engine operating speed of 3000 RPM and a 55% PTO. This results in an expected pump speed of 1650 RPM.

$$\text{Pump Speed} = \frac{\text{Engine Speed} \times \text{PTO}\%}{100} = \frac{3000 \times 55}{100} = \frac{165000}{100} = \mathbf{1650 \text{ RPM}}$$

If the PTO percentage available on the truck used differs by more than 10% from this figure, consult your dealer for recommendations. Too high a PTO percentage may overspeed the pump and may cause the pumping of excess oil so that overheating of the hydraulic system results. Too low a PTO percentage may pump too little oil so that inadequate spinner and auger speeds result, especially at lower engine speeds.

If you are supplying your own hydraulic pump system, it must be capable of delivering 20-25 GPM at the desired engine operating speed and be rated for 1500 PSI operation.

Pumps for Electric Clutch V-Belt Drive must operate in engine rotation direction (pump shaft must rotate in same direction as engine crankshaft). Those used for transmission PTO mounting are through-shafted and can operate on PTOs of either direction or rotation.



Transmission Pto Drive

The through-shaft pump and mounting bracket must be used on most any truck with an existing transmission PTO and continuously operating dump hoist pump installation.

⚠ WARNING

DO NOT check for leaks adjacent to moving parts while system is operating as there may be danger of entanglement! Failure to comply with this requirement could result in death or serious injury.

The pump is installed between the PTO and the existing pump. Determine the best location for the pump and mount on the bracket supplied. It may be necessary to modify the bracket to fit your truck since many variable factors, such as PTO make and model, muffler position, transmission make and model, etc., affect mounting position. **DO NOT WELD THE BRACKET TO THE TRUCK FRAME.** Install with mounting hardware supplied in the kit. Welding may void the truck manufacturer's warranty.

Position the mounting brackets so the pump drive shaft will be as straight as possible. In no case should the angle at any universal joint exceed 15°. The pump shaft and PTO shaft should be parallel. (Figure 1)

Check the rotation of the PTO for proper pump mounting. Make sure the pump is installed so it rotates in the proper direction.

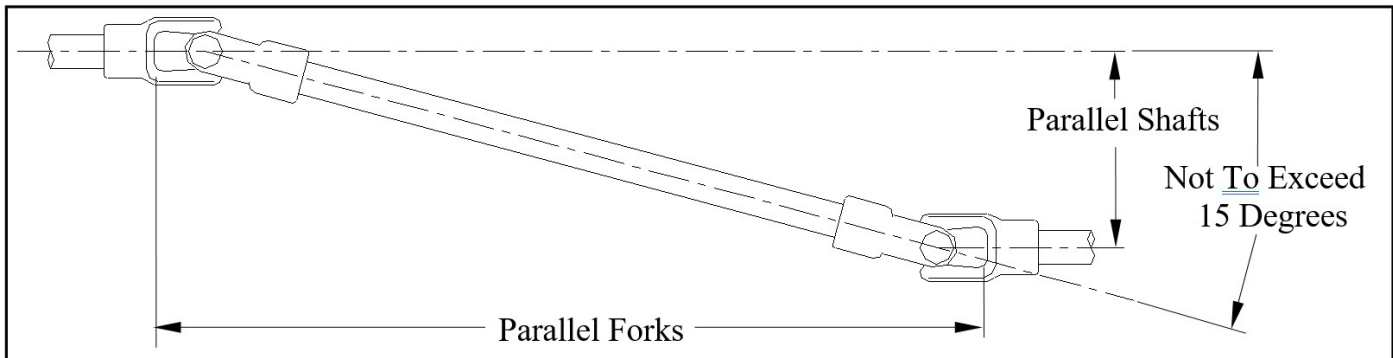

Figure 1 - Timing of Universal Joints

Hydraulic Pump Driveshaft

The pump driveshaft included may be too long for some installations. It may be cut and redrilled as necessary. When redrilling the shaft make sure the U-joints will be properly "timed" for smooth operation.

Install the slip joint at the end of the pump driveshaft. Failure to install the slip joint will result in bearing failure in pump, PTO or both.

All set screws in U-joint must be properly tightened. Cotter pins must be installed in shear pins and properly spread.

Electric Clutch V-Belt Drive

As available space around truck engine varies greatly from model to model, no specific mounting instructions can be given. The electric clutch pump assembly supplied will be rear ported and have two 7.082 inch diameter V-belt pulleys for 1/2" A-section V-belts. Two equal V-belt sheaves of approximately 6" to 7" diameter must be mounted on the front end of the engine crankshaft. Two V-belts of 1/2" A-section rated at 100 pounds per belt must be procured.

A mounting bracket to provide adequate belt adjustment must be fabricated locally. Your local truck dealer may be able to provide a bracket that can be readily adapted for this use. Check to be sure adequate belt, electric clutch, pump, hose and adjustment clearances are obtained.

Hydraulic hose and electric wire connections must be made to provide for adequate V-belt adjustment and to avoid interference with moving parts. Hot surfaces, such as exhaust manifolds, must be avoided.

If pump rear porting is not usable, side porting can be obtained on special order through your dealer.

HYDRAULIC RESERVOIR AND FILTER

The hydraulic reservoir is mounted on the truck frame on either side. It should be as close to the truck cab as practical and where filler neck is accessible with the suction line being as short as possible. Drill four 7/16" diameter holes through the frame channel vertical web for the mounting holes for the tank brackets and bolt the reservoir into place.

NOTICE

Keep holes away from frame top and bottom flanges. If holes are too close it may cause frame cracking.

The filter is installed on the tank using a pipe coupling and a close nipple. Use thread sealer as explained in the "Hydraulic Hose" section under Installation Instructions. The oil must flow through the filter in the direction of the arrow on the filter head casting. After installation, the element should be down and vertical.

Cab Control Valve

When selecting a location for the cab control, there are a number of things to consider:

1. Select a suitable location for the operator to adjust the control and to turn it On and Off.
2. Check for clearance with the seat in all positions.
3. Check the transmission gear shift in all gears for clearance with the valve and the valve lever in the On and Off positions.
4. If there are any other controls, such as parking brake, plow and wing controls, check for clearance.
5. Under the cab check for interference with transmission, etc.
6. Check to see that control valve location does not interfere with entering or leaving the cab.

CAUTION

All holes in the truck cab walls, floor and firewall for control wires, hoses and cables are to be grommetted, plugged and sealed to prevent entrance of engine fumes, dust, dirt, water and noise. Failure to follow this requirement may result in injury or machine damage.



Tailgate Filler Panels

Tailgate panels are furnished to bolt or weld to the inside rear corner of the tailgate.

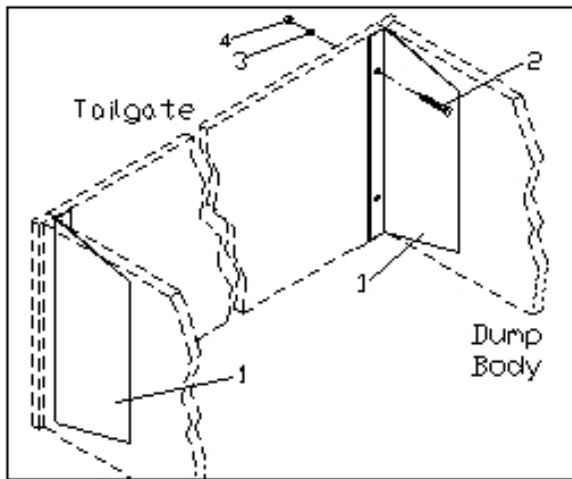

Figure 2 – Tailgate Panels

Parts needed:

ITEM	DESCRIPTION	QTY
1	Tailgate Panels	2
2	3/8 x 3 1/2 Cap Screw	4
3	3/8 Lock Washer	4
4	3/8 Hex Nut	4

1. Gather parts needed to install tailgate panels in truck dump body.
2. Figure 2 – Close the tailgate and slide each panel (1) down until it clears the floor by 1/8". Clamp into position with 1/8" clearance between the panel and the side of the dump body.
3. Swing the tailgate open approximately 8" and check clearance between panels and the floor. At an 8" gate opening, the leading edge of the panel should almost touch the floor itself.
4. Trim the top edge of the panel to suit the dump body and bolt in place using hardware provided.

Mounting Of Spreader

1. Measure overall width of dump body rub rail and overall width of spreader—these dimensions must be the same or spacers must be used to make them the same. (Spacers are not included.)

CAUTION

Stay out from under the spreader while it is supported under the truck body. If it falls, you could be injured. Watch out for pinch points between the spreader and the truck body. Failure to follow this requirement may result in injury or machine damage.

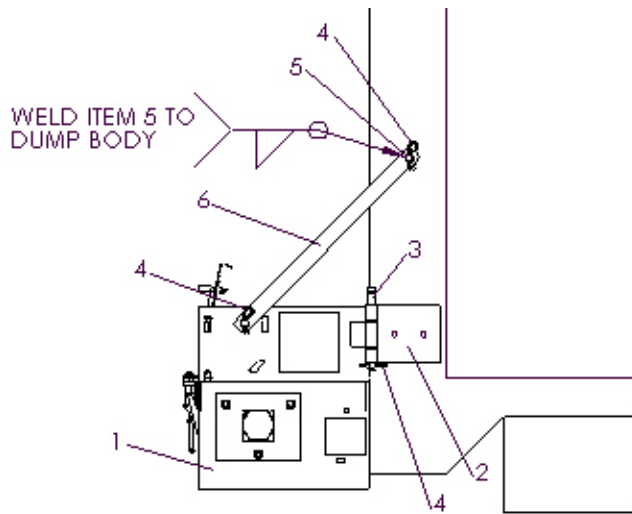

Figure 3 – Mounting

Parts needed:

ITEM	DESCRIPTION	QTY
1	Spreader	1
2	Mounting Bracket	2
3	Mounting Rod	2
4	Hairpin	2
5	Anchor Pin	2
6	Mounting Bar	2

WARNING

Use only lifting devices that meet or exceed OSHA standard 1910.184. Never lift equipment over people. Never lift unit with material in the body. Loads may shift or fall if improperly supported, causing injury or damage to the unit. Failure to comply with this requirement could result in death or serious injury.

2. Raise and position Spreader (1) as high as possible, usually against the bottom of the tailgate lock, with the motor to the right. Remember that the tailgate of the truck should lay horizontally over the Spreader. Make sure the tailgate and tailgate latch can operate properly with the Spreader installed.
3. Attach Mounting Bracket (2) to each side of the dump body by welding or using a minimum of two 1/2" cap screws per Bracket.
4. Lift Spreader into position, insert Mounting Rods (3) and secure with Hairpins (4).
5. Place Mounting Bars (6) on pins attached to Spreader and place Anchor Pins (5) on opposite ends. Position Mounting Bars diagonally as shown in Figure 3 and mark location of Anchor Pins on both sides of dump body. Remove Mounting Bars.
6. Weld Anchor Pin to dump body corner post where marked.
7. Place Mounting Bars on Pins and secure with hairpins (4).

If there is a gap between the hopper lip and the dump body rear cross member, a "spill board" of about 3/16" x 2" steel may be welded to the dump body. This forms a seal at the leading edge of the spreader hopper. It may have to be notched or cut to fit around tailgate latches or other obstructions at the rear of the dump body.



Installation Instructions Cont.

Spinner Assembly

The spinner assembly is installed on two brackets near the left-hand end of the spreader underneath the trough. (Figure 4)

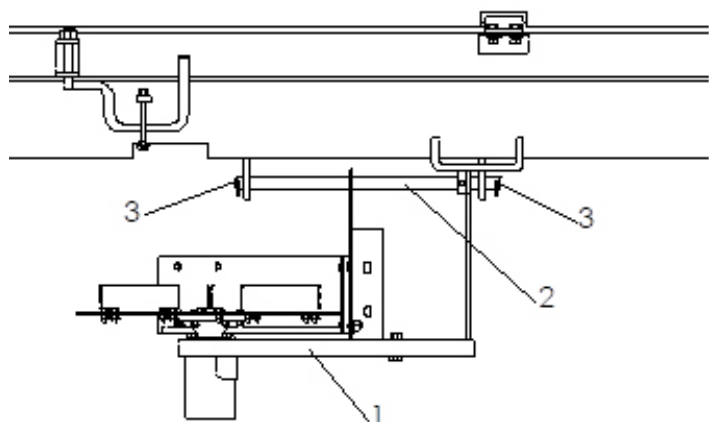

Figure 4 – Spinner Mount

Parts needed:

ITEM	DESCRIPTION	QTY
1	Spinner Assembly	1
2	Hinge Rod	1
3	Hairpin	2

1. Assemble spinner as shown under "Spinner" in the Parts List section at the back of this manual.
2. Install Spinner Assembly (1) by inserting Hinge Rod (2) as shown in Figure 4 and secure with Hairpin (3) at each end.
3. Vary the spread pattern by sliding the Spinner Assembly on the Hinge Rod. Place Spinner Assembly in desired position and tighten collar set screw.

Installation Instructions Cont.

Leveling Mechanism

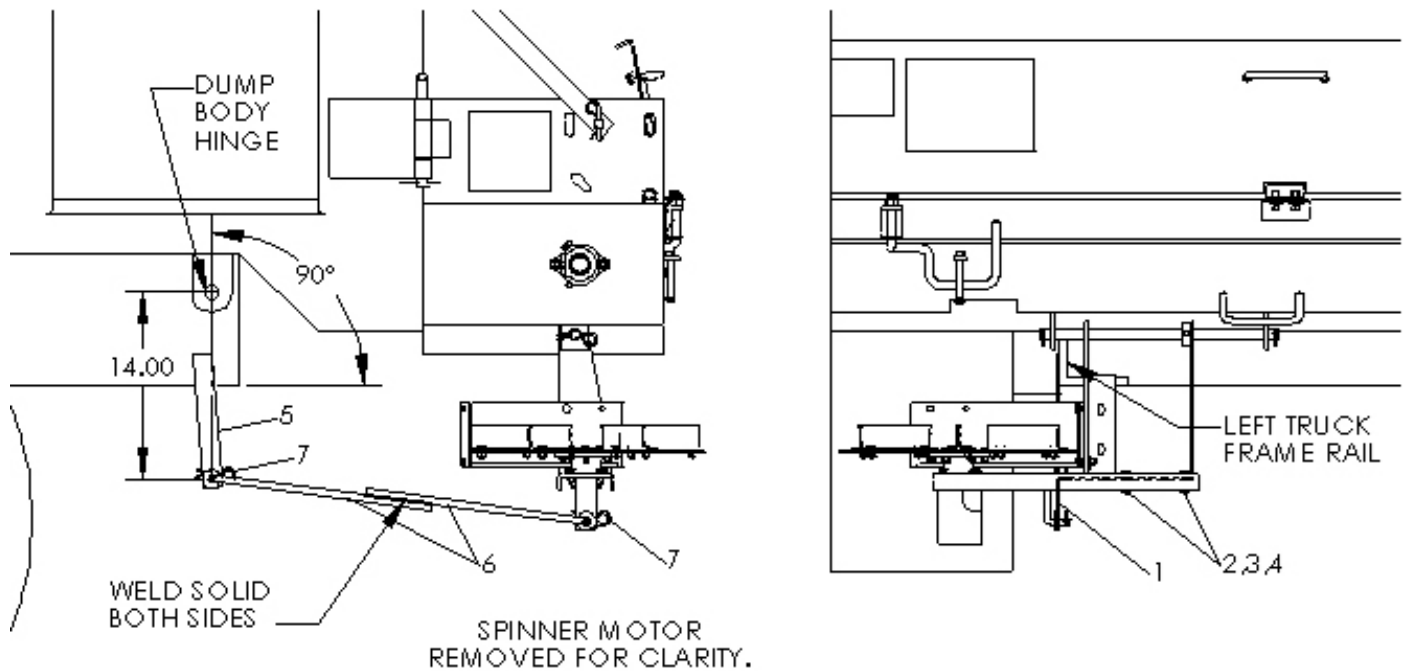

Figure 5 - Leveling Mechanism

Parts needed:

ITEM	DESCRIPTION	QTY
1	Mounting Angle	1
2	Cap Screw – 3/8 x 1-1/2	2
3	Lock Washer – 3/8	2
4	Hex Nut – 3/8	2
5	Frame Bracket	1
6	Linkage Rod	2
7	Hairpin	2

The leveling mechanism may now be mounted. Clamp the Frame Bracket (5) to the outside of the right truck frame rail. The center of the Frame Bracket hole should be exactly 14.00" directly below the dump body hinge pin center line as shown in Figure 5. If this is not possible, locate the Frame Bracket hole center as close as possible ahead and/or below this point. Adjust the Mounting Angle (1) to line up with the Frame Bracket. Install the two Linkage Rods (6), secure with Hairpins (7) and clamp together.

Carefully raise the dump body through its complete range of movement. Make sure the spinner stays level throughout the range of movement. Adjust the position of the Mounting Angle and the length of the Linkage as necessary until the spinner stays level.

Attach the Frame Bracket to the truck frame after it's properly aligned. Weld the Linkage Rods thoroughly at the lapped joint. Paint the welded area to retard rust formation.



Hydraulic Hose Installation

Determine the pressure port of the pump. Install the pressure hose into this port as shown in Figure 16. Connect the suction hose to the opposite port and to the tank outlet on the reservoir. If necessary, use plastic tie straps to support hoses so that they will not catch on field obstructions or contact the muffler or moving parts.

Use thread sealer on all fittings, except "O" ring and JIC adapters, "O" ring valves and motors, etc. When using thread sealer, do not put it on the first three threads of the fitting. Too much sealer on the fitting or on the first three threads will force it into the oil stream where it could damage the system.

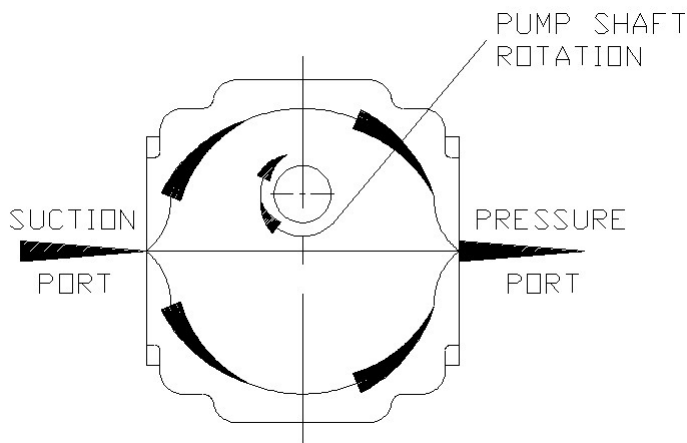

Figure 16 – Hydraulic Pump

CAUTION

If a threaded connection is tightened too tightly, the fitting or housing into which the fitting is placed could be distorted and an unstoppable leak could occur. Failure to follow this requirement may result in injury or machine damage.

Assemble the system as shown in the "Hydraulics System" parts list. Place the hose clamps as needed to keep hoses away from hot or moving parts. Do not let hoses hang so low as to be snagged. Do not stretch hoses tight.

The hydraulic hoses supplied are as follows:

Pressure Line - Two wire braid hose, one end fitting crimped on, other end fitting to be field installed after cutting hose to length. See assembly instructions on the following pages.

Suction Line - Single spiral wire reinforced to be cut to length. Fittings to be assembled with double hose clamps.

All Return Lines - Double cotton braid to be cut to length as necessary. Fittings to be assembled with single hose clamps.

Installation Instructions Cont.

Reusable Non-Skive Type Ends

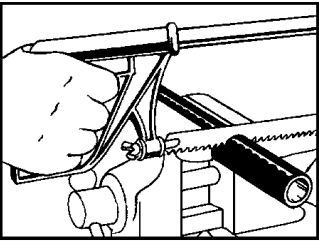
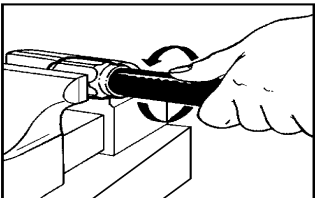
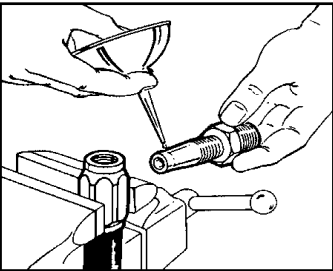
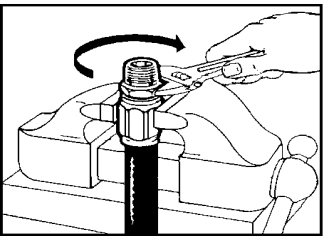
	<p>Step 1 Cut hose to length required using a fine tooth hacksaw or cut-off machine. Clean hose bore.</p>
	<p>Step 2 Liberally lubricate hose cover with hose assembly lube. Place socket in vise and turn hose into socket counterclockwise until it bottoms. When assembling long lengths of hose, it may be preferred to put hose in the vise just tight enough to prevent from turning, and screw socket onto the hose counterclockwise until it bottoms.</p>
	<p>Step 3 Liberally lubricate nipple threads and inside of hose. Use heavy weight oil.</p>
	<p>Step 4 Screw nipple clockwise into socket and hose. Leave 1/32" (.08cm) to 1/16" (.16cm) clearance between nipple hex and socket. Disassemble in reverse order. Used with permission of the Aeroquip Company</p>

WARNING

Do not use one manufacturer's hose with another manufacturer's fittings! Such use will void any warranty and may cause premature burst or leak of hydraulic fluids! Such bursting or leaking may cause severe injury and/or fire! Failure to comply with this requirement could result in death or serious injury.



Installation Instructions Cont.

Hydraulic Hose Maintenance

Hose assemblies in operation should be inspected frequently for leakage, kinking, abrasion, corrosion or other signs of wear or damage. Worn or damaged hose assemblies should be replaced immediately.

▲ WARNING

Testing should be conducted in approved test stands with adequate guards to protect the operator. Failure to comply with this requirement could result in death or serious injury.

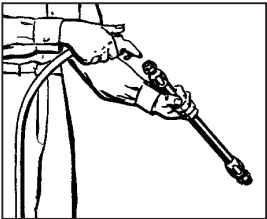

Clean

Clean assembly by blowing out with clean compressed air. Assemblies may be rinsed out with mineral spirits if the tube stock is compatible with oil, otherwise hot water at 150°F (65.55° C) maximum may be used.

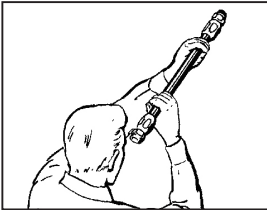

Inspect

Examine hose assembly internally for cut or bulged tube, obstructions, and cleanliness. For segment style fittings, be sure that the hose butts up against the nipple shoulder; band and retaining ring are properly set and tight, and segments are properly spaced. Check for proper gap between nut and socket or hex and socket. Nuts should swivel freely. Check the layline of the hose to be sure the assembly is not twisted. Cap the ends of the hose with plastic covers to keep clean.

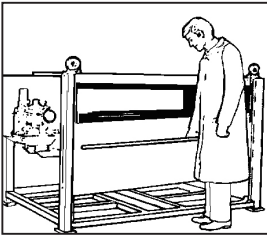

Test

The hose assembly should be hydrostatically tested at twice the recommended working pressure of the hose.

Test pressure should be held for not more than one minute and not less than 30 seconds. When test pressure is reached, visually inspect hose assembly for: 1. Any leaks or signs of weakness. 2. Any movement of the hose fitting in relation to the hose. Any of these defects are cause for rejection.

Storage and Handling

Hose should be stored in a dark, dry atmosphere away from electrical equipment, and the temperature should not exceed 90° F (32° C).

Installation Instructions Cont.

Hydraulic Hose Installation Guide

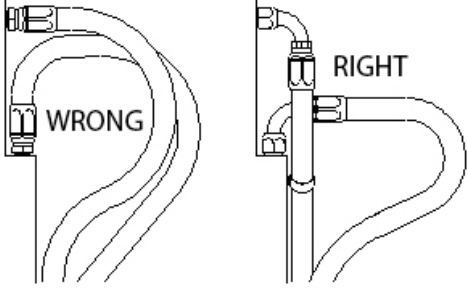
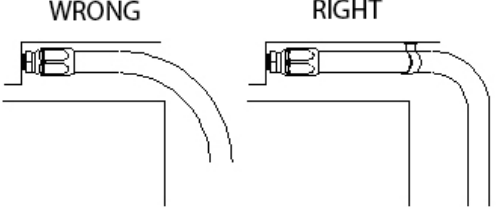
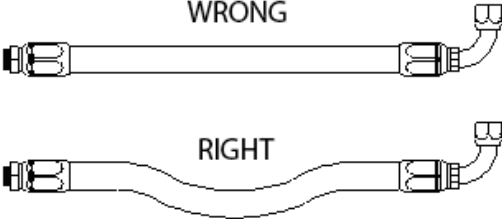
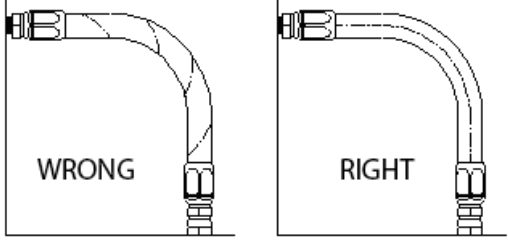
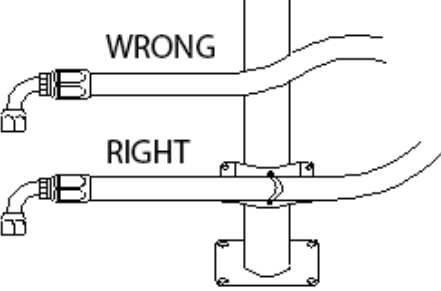
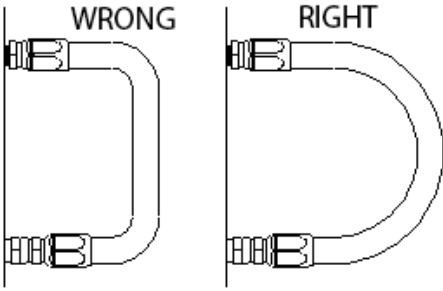
	
<p>1. Use elbows and adapters in the installation to relieve strain on the assembly, and to provide easier and neater installations that are accessible for inspection and maintenance. Remember that metal end fittings cannot be considered as part of the flexible portion of the assembly.</p>	<p>2. Install hose runs to avoid rubbing or abrasion. Clamps are often needed to support long runs of hose or to keep hose away from moving parts. It is important that the clamps be of the correct size. A clamp that is too large will allow the hose to move in the clamp causing abrasion at this point.</p>
	
<p>3. In straight hose installations allow enough slack in the hose line to provide for changes in length that will occur when pressure is applied. This change in length can be from +2% to -4%.</p>	<p>4. Do not twist hose during installation. This can be determined by the printed layline on the hose. Pressure applied to a twisted hose can cause hose failure or loosening of the connections.</p>
	
<p>5. Keep hose away from hot parts. High ambient temperature will shorten hose life. If you cannot route it away from the heat source, insulate it.</p>	<p>6. Keep the bend radii of the hose as large as possible to avoid hose collapsing and restriction of flow. Follow catalog specs on minimum bend radii.</p>

(Used with the permission of The Weatherhead Company.)



Electrical Connections

Connect all electrical control circuits. The supply conductor should be connected to the accessory terminal of the truck ignition switch through the fifteen amp. circuit breaker provided in the control panel. All wiring should be approved automotive insulated wire, should be supported adequately with insulating ties or straps, should be located where it will not interfere with any control access, does not contact any moving parts or sharp edge and is kept away from any hydraulic line or any heated part.

Lights

Lights and reflectors are provided to meet DOT FMVSS 108 requirements but not necessarily any other applicable local, regional or national codes. Install lights and reflective devices to conform to DOT FMVSS-108 and state requirements.

Filling The Hydraulic System

NOTICE

DO NOT attempt to run pump without first filling hydraulic oil reservoir and opening suction line gate valve, or pump may be ruined.

Fill reservoir with hydraulic oil as specified in the Lubricant Specifications section of this manual. Be sure oil is clean, free from dirt, water and other contaminants.

Lubricate all points requiring lubrication per Lubrication Chart in this manual.

Checking Installation

See "Initial Start-Up" procedure.

**OPERATIONS
&
MAINTENANCE**

General Description

The SA-6C unit is an under-tailgate-type spreader designed for spreading abrasives and/or chemicals, primarily for ice and snow control.

The SA-6C is a single spinner, single auger spreader. The entire unit mounts to the sides of a dump body level with the floor of the box. A quick-disconnect mounting kit allows for installation and removal without the use of tools.

The bottom trough functions as a hopper clean-out. It is held in place by a latch assembly.

The rear cover can be repositioned for use as a hopper cover. This allows normal dumping from the box without filling the hopper with material or removing the spreader.

The SA-6C uses a single six-inch diameter auger with bi-directional flighting. A removable anti-flow cover plate prevents material spillage when the auger isn't operating.

The SA-6C is powered hydraulically. The standard control system is a manual dual hydraulic system, which provides independent variable speed control for both the auger and the spinner.

The auger is powered by a direct drive hydraulic motor. A worm gear drive option is available. The other end of the auger is supported by a flange-type ball bearing.

A gear-type hydraulic pump provides power to operate the units. Pump drives available are:

1. Through-shaft pump for truck transmission drive.
2. Electric clutch engaged V-belt drive from crankshaft pulley.

This product is intended for commercial use only.

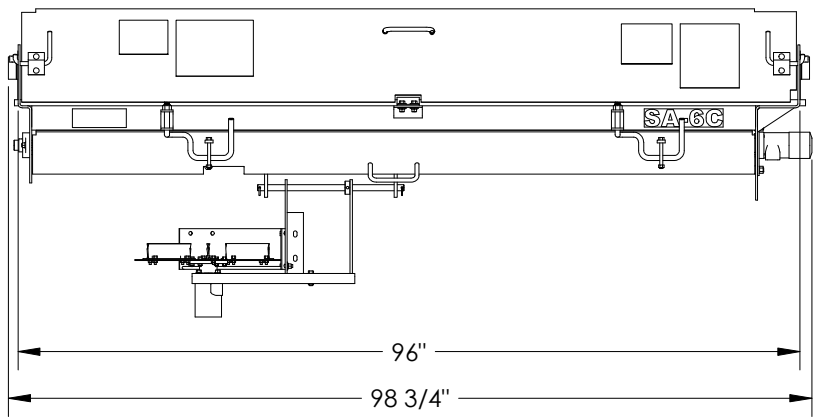
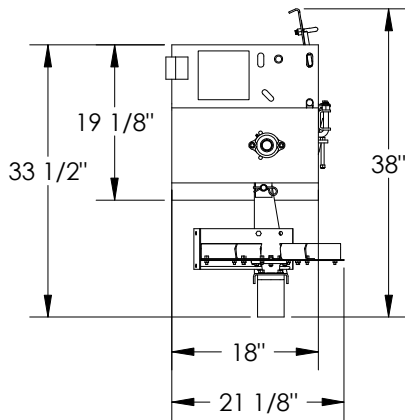

	H HEIGHT	D DEPTH	L LENGTH
With Spinner (W/S)	33.5" (851 mm)	21.125" (536 mm)	98.75 (2508 mm)
Without Spinner	19.125" (486 mm)	18" (457 mm)	96" (2438 mm)

Initial Start-Up

Check over the entire unit to be sure all fasteners are in place and properly tightened per Torque Chart in this manual. Disengage PTO driving pump. Be sure On-Off control in cab is in the Off position. Do not load the spreader.

1. Check to see that no loose parts or other material is in the spreader or on the spinner disc.
2. Fill the hydraulic tank with oil. Refer to the Lubricant and Hydraulic Oil Specifications section for proper oil.
3. Start engine. Engage PTO or actuate electric clutch switch (if applicable). Let the engine run at approximately 1000 RPM for a few minutes allowing the oil to circulate through pump and back to the reservoir. In cold weather allow greater warm-up time.
4. Place the cab On-Off control in the On position and open the spinner control approximately 1/4. Let the unit run until the air is expelled from the circuit and the spinner is running smoothly. The spinner should rotate counter-clockwise when viewed from the top. Turn the spinner to the Off position.
5. Open auger control approximately 1/4. The auger flighting should move to the center of the spreader. Let the unit run for a few minutes until the auger is running smoothly.
6. Move the spinner and auger control to 1/2 and allow both spinner and auger to run. Shut down system.

⚠ WARNING Stand clear of moving machinery. Failure to comply with this requirement could result in death or serious injury.

7. Check all connections in the hydraulic system to make sure that there are no leaks.

⚠ WARNING

DO NOT check leaks with hands while system is operating as high pressure oil leaks can be dangerous! If skin is pierced with hydraulic fluid at high pressure seek immediate medical attention as fluid injected into the skin could cause gangrene if left untreated. Relieve pressure before disconnecting hydraulic lines or working system. Make sure all hydraulic fluid connections are tight and all hydraulic hoses and lines are in good condition before applying pressure to the system. Wear protective gloves and safety glasses or goggles when working with hydraulic systems. Failure to comply with this requirement could result in death or serious injury.

⚠ WARNING

DO NOT check for leaks adjacent to moving parts while system is operating as there may be danger of entanglement! Failure to comply with this requirement could result in death or serious injury.

8. Check hydraulic oil reservoir and refill to full mark. Fill gear case with oil if applicable. Unit is now ready for road testing.



General Operating Procedures

Before taking the unit out to use, make a walk-around inspection to assure that the spreader is not damaged, that all essential parts are in place, and that all fasteners are tight and all guards are in place. Check all controls to be sure they are operating satisfactorily.

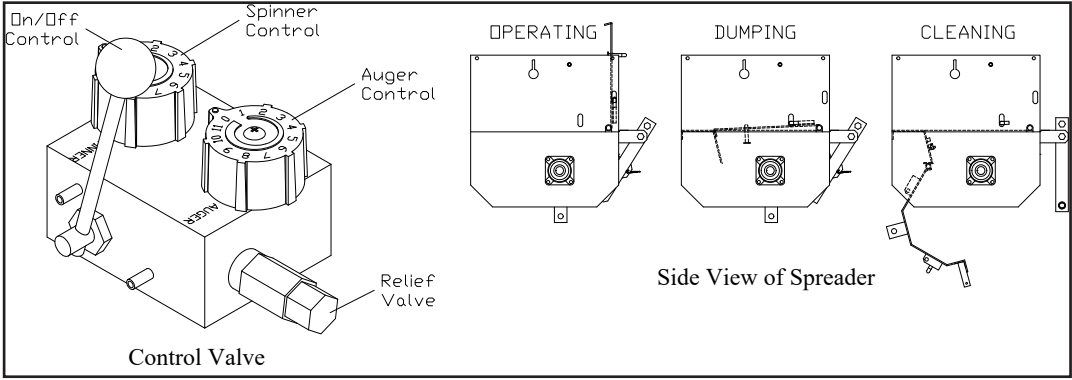

Figure 1 - Operating Controls

CAUTION

Check for clearance before releasing trough for cleaning. It may swing open suddenly. Material in the trough will dump quickly. Failure to follow this requirement may result in injury or machine damage.

Position the rear cover vertically and secure with the pivot rods.

Adjust the dump body's tailgate chains to hold the tailgate in the required position. This adjustment is by trial and error and depends on the flow characteristics of the material being spread. The gate should be open only enough to keep the material freely flowing to the auger. The tailgate should not touch the rear cover.

NOTICE

Make sure trough bottom is secured before filling with material to be spread.

A wide open tailgate on certain materials will tend to stall the auger resulting in uneven delivery of material. With free flowing salt, the tailgate may be chained with only a 3" (7.6cm) or 4" (5.1cm) opening.

If the material to be spread is not already in the dump body, have the unit loaded. With On-Off control in Off position, engage pump drive and allow oil to circulate until it is warm. This may be done while traveling to loading or starting point. The colder the weather, the more important this warm-up becomes.

All spinner adjustments must be made with On-Off control in Off position to stop spinner and auger to avoid injury from spinner and/or discharging material.

Set variable speed spinner control to obtain spread width desired. Spinner speed and position, as well as material granule size, density and moisture content affect spread width, so proper settings are gained by trial and experience.

Spinner speed selected should be the lowest required to obtain the desired spread width with the material being spread. Use of higher spinner speeds will increase wear and tear on parts. It will waste material, and can create excessive damage to vehicle finish through uncontrolled throwing and bounce of materials.



General Operating Procedures Continued

Spread pattern is determined by the mounting position of the spinner assembly. Lateral adjustment of the assembly is made by sliding it along the hinge pin. Lock the assembly in place by tightening set screw.

Slide the spinner to the far left and tighten the set screw. Spread a small amount of material to determine placement of material at various spinner and auger speeds in this position.

Slide the spinner to the far right and tighten the set screw. Make the same checks as above.

NOTE: Close the tailgate before loading and when traveling to the point where spreading is to begin. Open the tailgate just before starting to spread.

If the auger jams while spreading, follow this procedure:

1. Place On-Off control in Off position.
2. Open the bottom panel.
3. Allow any obstructions to fall to the ground.
4. Push the latch handle down to reposition bottom panel. Replace snap pins.



Never attempt to open the bottom panel with the augers or spinner turning. Failure to comply with this requirement will result in death or serious injury.



Check for clearance before releasing trough for cleaning. It may swing open suddenly. Material in the trough will dump quickly. Failure to follow this requirement may result in injury or machine damage.

The rear cover lays down flat on top of the spreader hopper so the dump body may be used without removing the spreader hopper. Follow the procedure below:

1. Place On-Off control in Off position.
2. Unlatch rear cover at each end by rotating pivot rods and pulling out of slots in trough side panels.
3. Pivot the cover until it is flat.
4. Insert the pivot rods through lower slots in trough side panels to retain the cover.

NOTE: Disengage PTO when spreader is not in use for long periods of time or when moving to and from job site after initial warm-up.



General Operating Procedures Continued

VALVE POSITION	VEHICLE SPEED (MPH)						
	8.9	6.7	5.4	4.5	3.8	3.4	
APPROX. DELIVERY RATE (CU. FT/MI)	1	12.7	9.5	7.6	6.4	5.5	4.8
	2	16.7	12.5	10.0	8.4	7.2	6.3
	3	20.7	15.5	12.4	10.4	8.9	7.8
	4	24.0	18.0	14.4	12.0	10.3	9.0
	5	27.5	20.7	16.5	13.8	11.8	10.3
	6	30.6	22.9	18.4	15.3	13.1	11.5
	7	33.4	25.1	20.1	16.7	14.3	12.5
	8	36.2	27.2	21.7	18.1	15.5	13.6
	9	38.1	28.6	22.9	19.1	16.3	14.3
	10	38.6	28.9	23.2	19.3	16.5	14.5
	11	52.0	39.0	31.2	26.0	22.3	19.5

NOTE: Rates shown above are for units with direct drive augers only.

Automatic Dual Control System

This system uses a ground-speed sensing arrangement to automatically adjust the auger portion of the dual control valve so that auger speed is coordinated with ground speed. The system has three basic speed rates. They are normally calibrated to give light, normal or heavy applications.

As factory settings of the system may not be suitable, the system should be adjusted before use. Calibration instructions are included in the Fluid Controls, Inc. Hydra-Tach Adjustment instructions in the installation manual.

If the tachometer simulator (GTS-1300) mentioned in the manual is not available, the truck can be driven on a smooth roadway at speeds indicated in the adjustment instructions to obtain proper ground speed signals; follow the remainder of the instructions for adjustment.

⚠ WARNING	Do not jack up or block up rear wheels so that road speeds can be simulated, since vibration from engine, driveline and wheels could jar truck off of jacks or blocks and cause an accident. Failure to comply with this requirement could result in death or serious injury.
------------------	---



General Operating Procedures Continued

Hydraulic System

When the engine is running and the PTO or electric clutch is engaged, the pump delivers oil to the cab control valve. If the On-Off valve is in the Off position, the oil flows through the valve and returns to the reservoir.

When the On-Off control is moved to the On position, the oil will still flow through the valve and back to the reservoir as long as the spinner and auger control are Off.

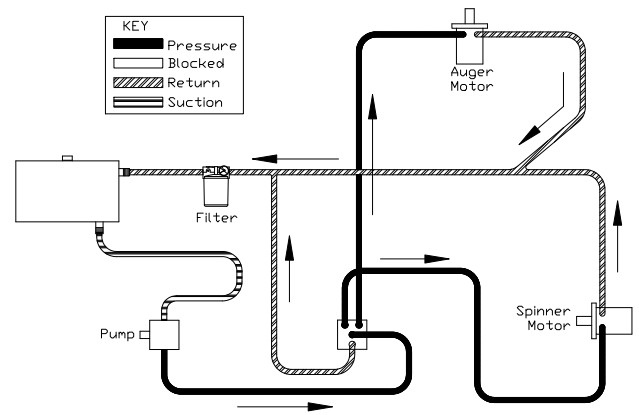

Figure 2 - Hydraulic System Schematic

When the auger or spinner control is rotated, oil under pressure is metered to the spinner or auger motors. The further the control is moved, the more oil is sent to the motors, the faster they turn. Excess oil is returned from the control to the reservoir through a return line. After passing through the motors, that oil is also returned to the reservoir through return lines.

All the hydraulic oil flows through an oil filter before entering the hydraulic reservoir. There is a bypass in the filter. If the filter is clogged, oil will flow through the bypass instead of the filter element. This condition is indicated when the filter indicator gauge is in the "Red" or "Danger" zone. The filter element must be changed.

To reverse auger rotation, switch the pressure and return hoses at the ports on the auger motor.

Pressure Setting

The system relief is located in the cab control valve and is set at 1500 PSI. The pressure can be set as follows:

1. Turn both auger and spinner controls to "Off". Disengage the PTO.
2. Disconnect the pressure line leading to the spinner motor. Install a gauge of at least 2000 PSI capacity in the line. Block the line downstream from the gauge. The easiest way to do this is to install a "Tee" in the line. Block one port on the "Tee" and install a gauge in the other. Make sure the "Tee" is capable of withstanding 2000 PSI.
3. Engage the PTO. Start the engine. Turn the spinner control full "On" and read the pressure. Adjust the relief valve as required.

NOTE: Back off on the adjustment, then turn back in until proper pressure is reached. Tighten the jam nut on the relief valve.

⚠ WARNING

Do not jack up or block up rear wheels so that road speeds can be simulated, since vibration from engine, driveline and wheels could jar truck off of jacks or blocks and cause an accident. Failure to comply with this requirement could result in death or serious injury.

Turn the control to the Off position. Shut off engine. Disengage PTO. Remove the gauge and reconnect the hydraulic lines.

Lubrication and Maintenance

Preventative Maintenance Pays!

The handling and spreading of salt and sand is a highly severe operation with respect to metal corrosion. Establish a frequent, periodic preventative maintenance program to prevent rapid deterioration to equipment. Proper cleaning, lubrication and maintenance will yield longer life, more satisfactory service and more economical use of your equipment.

⚠ WARNING

Shut off all power and allow all moving parts to come to rest before performing any maintenance operation. Failure to comply with this requirement could result in death or serious injury.

Hydraulic System

Proper oil in the hydraulic system is one of the most important factors for satisfactory operation. Utmost cleanliness in handling the oil cannot be stressed enough. Keep hydraulic oil in original closed containers, clean top of container before opening and pouring, and handle in extremely clean measures and funnels.

Refer to "Lubricant and Hydraulic Oil Specifications" for selection of the proper hydraulic fluid for use in the hydraulic system.

Service Schedule

⚠ WARNING

DO NOT check leaks with hands while system is operating as high pressure oil leaks can be dangerous! If skin is pierced with hydraulic fluid at high pressure seek immediate medical attention as fluid injected into the skin could cause gangrene if left untreated. Relieve pressure before disconnecting hydraulic lines or working system. Make sure all hydraulic fluid connections are tight and all hydraulic hoses and lines are in good condition before applying pressure to the system. Wear protective gloves and safety glasses or goggles when working with hydraulic systems. Failure to comply with this requirement could result in death or serious injury.

⚠ WARNING

DO NOT check for leaks adjacent to moving parts while system is operating as there may be danger of entanglement! Failure to comply with this requirement could result in death or serious injury.

Check hydraulic oil daily by means of sight gauge on reservoir. Add oil as necessary to maintain level around mid-point of sight gauge. Periodically inspect hoses and fittings for leaks.

NOTICE

Change hydraulic oil filter after first week (or not more than 50 hours) of operation on a unit.

After first filter change, replace filter when indicator reaches Red Zone.

Drain reservoir through drain plug (not through suction outlet), flush, and refill and change filter element annually. Oil and filter should also be changed whenever oil shows any signs of breaking down under continued high-pressure operation. Discoloration of oil is one sign of breakdown.

Lubrication and Maintenance Continued

Lubrication of Bearings

Grease in a bearing acts to prevent excessive wear of parts, protects ball races, and balls from corrosion and aids in preventing excessive heat within the bearing. It is very important the grease maintain its proper consistency during operation. It must not be fluid and it must not channel.

Make sure all fittings are thoroughly cleaned before grease is injected. Points to be lubricated by means of a grease gun have standard grease fittings.

Lubricate bearings by pumping grease slowly until it forms a slight bead around the seals. This bead indicates adequate lubrication and also provides additional protection against the entrance of dirt.

Fasteners

Tighten all screws fasteners to recommended torques after first week of operation and annually thereafter. If loose fasteners are found at anytime, tighten to recommended torque. Replace any lost or damaged fasteners or other parts immediately. Check body mounting hardware every week.

Clean-Up

NOTICE High pressure wash can inject water and/or fertilizer into control components, causing damage. Use caution when cleaning these areas.

Thoroughly wash unit every two to three days during the operating season to maintain minimal maintenance operation. Hose unit down under pressure to free all sticky and frozen material.

It is important the unit be thoroughly cleaned at the end of each operating season. All lubrication and maintenance instructions should be closely followed. Repaint worn spots to prevent formation of rust.

MULTIBIN Meter Wheel(s): Pull inspection plug on right hand side of micro assembly. Blow out with compressed air.



Lubricant and Hydraulic Oil Specifications

NOTICE

The lubricant distributor and/or supplier is to be held responsible for results obtained from their products. Procure lubricants from distributors and/or suppliers of unquestionable integrity, supplying known and tested products. Do not jeopardize your equipment with inferior lubricants. No specific brands of oil are recommended. Use only products qualified under the following oil viscosity specifications and classification recommended by reputable oil companies.

Hydraulic System

The following are the recommended procedures for selecting the proper hydraulic fluid for use in the hydraulic system. Select a major brand industrial PREMIUM QUALITY (anti-wear type) hydraulic oil to provide viscosity between 100-200 SSU at operating temperature. Premium hydraulic oils with viscosity indexes of 95 or above will provide the following temperature ranges :

INDUSTRY IDENTIFICATION/ SAE VISCOSITY GRADE	OPERATING TEMPERATURE	VISCOSITY
150 SSU	122° F (50° C)/84° F (28.9° C)	100 SSU/200 SSU
225 SSU	140° F (60° C)/107° F (41.7° C)	100 SSU/200 SSU
300 SSU	150° F (66.6° C)/116° F (46.1° C)	100 SSU/200 SSU
450 SSU	165° F (73.9° C)/130° F (54.5° C)	100 SSU/200 SSU
600 SSU	182° F (83.3° C)/145° F (62.8° C)	100 SSU/200 SSU

If, because of necessity or convenience, it is desirable to use an automotive engine oil, multi-viscosity oils of SC rating (formerly MS quality) which will provide between 100-200 SSU at operating temperature can be used. These will provide proper viscosity over a wide range. For example:

SAE VISCOSITY GRADE	OPERATING TEMPERATURE	VISCOSITY
10W-30	130° F (54.5° C)	100 SSU
	100° F (37.8° C)	200 SSU
10W-40	190° F (87.8° C)	100 SSU
	140° F (60° C)	200 SSU

Gearcase Lubricant

Gear cases are factory equipped with synthetic oil for best performance at high loads. Lubricate the gearcase with multi-purpose gear lubricating oil conforming to MIL-L2105B according to the chart below:

PART	REFILL CAPACITY	40° to 120° F (4.5° to 49° C)	BELOW 40° F (4.5° C)
Gearcase	0.75 pints (0.35 liters)	SAE 85W 140	SAE 88W 90

Lubricant and Hydraulic Oil Specifications Continued

Grease Gun Lubricant

Use a ball and roller bearing lithium base lubricant with a minimum melting point of 300° F (148.9° C). This lubricant should have a viscosity that assures easy handling in the pressure gun at prevailing atmospheric temperatures. The lubricant must be waterproof. The grease should conform to NLGI No. 2 consistency.



Lubrication Chart

⚠ WARNING

Shut off all power and allow all moving parts to come to rest before performing any maintenance operation. Failure to comply with this warning could result in death or serious injury.

The spreader should be regularly lubricated with the lubricants recommended in this manual in accordance with the following chart:

LOCATION	PLACES	METHOD	FREQUENCY
Transmission PTO			
Slip Joint	1	Grease Gun	Weekly
U-Joint	2	Grease Gun	Monthly
Hydraulics			
Reservoir	1	Oil	Check Daily; Change Annually
Filter	1	Check Daily; Change Element when Indicated (Red)	
Control Valve – Hex Valve Stem (Under hand knob)	2	Hand Grease	Check Annually
Auger			
Bearings	1	Grease Gun	Weekly
Gear Case	1	Fill through vent plug	Check Monthly; Change Annually

NOTE: Unusual conditions, such as excessive dust, temperature extremes or excessive moisture may require more frequent lubrication of specific parts.

* See Lubricant and Hydraulic Oil Specifications for types of lubricants and oil to be used.

1. Symptom: Neither auger nor spinner will operate.

Reason	Correction
A. Low reservoir oil level.	Check and fill as required.
B. PTO not engaged.	Engage PTO. Check for broken or disconnected control cable.
C. PTO malfunction.	Check out PTO.
D. Electric clutch malfunction.	Check out electric clutch.
E. Drive belts slipping or broken.	Check out belts. Replace or adjust tension as required.
F. Pump driveshaft.	Check for broken or disconnected pump driveshaft.
G. Pump not rotating.	Check for broken key in pump. Also see C- F above.
H. Worn pump.	Check with flow meter.
I. Relief valve set too low.	Adjust relief valve setting.

2. Symptom: Auger operates but spinner doesn't.

Reason	Correction
A. Spinner jammed.	Turn spinner control Off, then check for jams.
B. Motor not turning spinner.	Check for broken key or failed motor. Repair or replace.
C. Pinched or crushed hoses or lines.	Repair or replace as required.

3. Symptom: Spinner operates but auger doesn't.

Reason	Correction
A. Auger jammed.	Turn auger control Off, then check for jams.
B. Gear case drive.	Check for broken or missing keys, broken shafts or broken gears. Check the auger drive bolt. Repair or replace as necessary.
C. Frozen bearings.	Turn auger control Off, then check bearings. Replace as required.
D. Motor doesn't turn auger.	Check for broken key or failed motor. Repair or replace.
E. Pinched or crushed hoses or lines.	Repair or replace as required.

4. Symptom: Hydraulic oil overheats.

Reason	Correction
A. Low oil level.	Check oil level. Add as necessary.
B. Check for proper pump/PTO matching.	Install proper sized pump.
C. Incorrect relief valve setting.	Check setting. Adjust to proper setting.
D. Pinched or crushed hoses and lines.	Repair or replace as required.
E. Worn motor in system.	Repair or replace as required.



NOTE: This schematic only valid with use of Hi-Way valve.

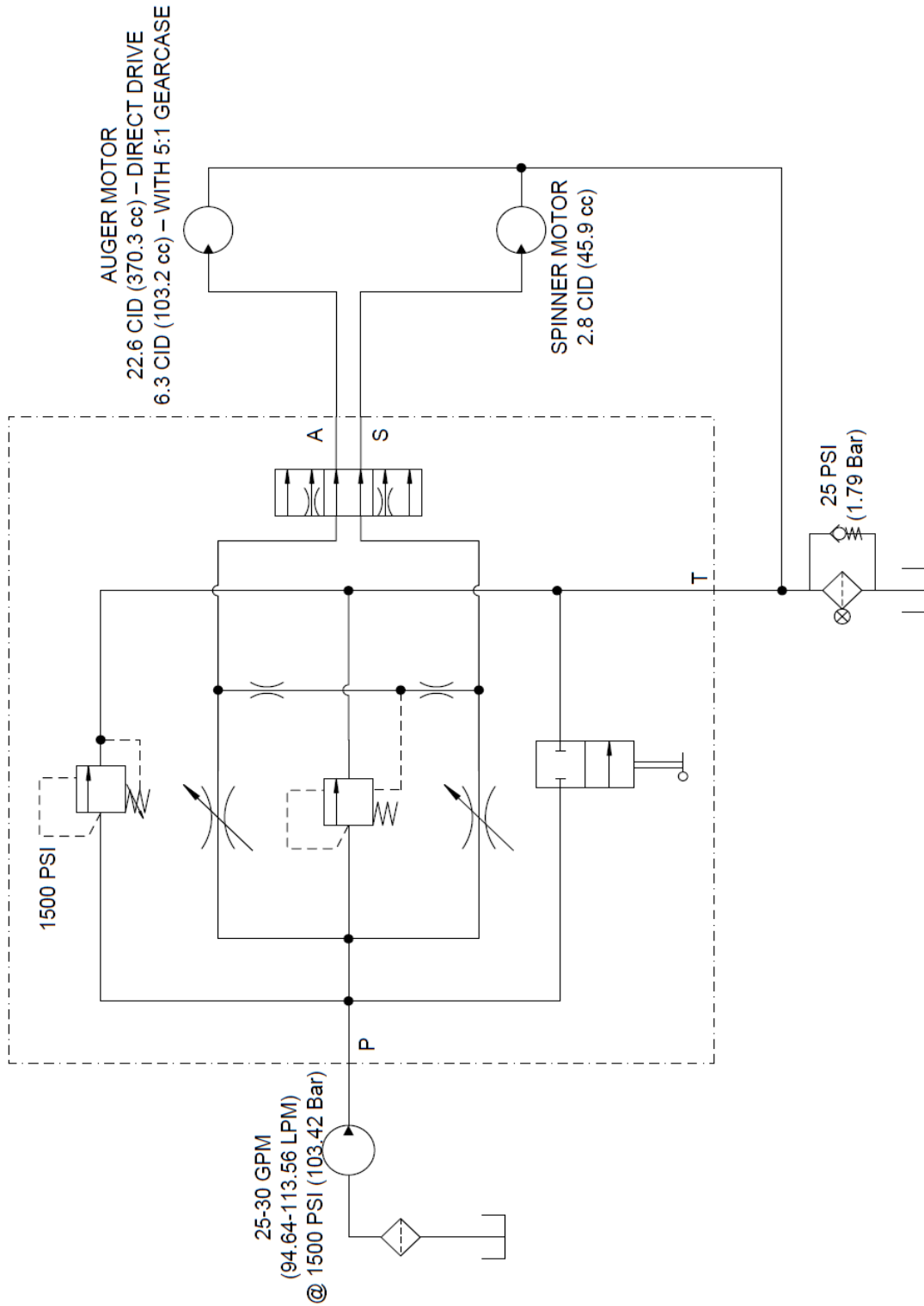

CAP SCREW GRADE IDENTIFICATION - MARKINGS ON HEAD

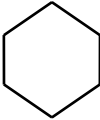
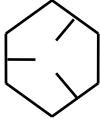
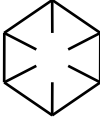
- SAE GRADE 2  NO MARKINGS
- SAE GRADE 5  THREE MARKS - 120 DEGREES APART
- SAE GRADE 8  SIX MARKS - 60 DEGREES APART

USE GRADE 2 TORQUES FOR STAINLESS STEEL FASTENERS AND CARRIAGE BOLTS.

CAP SCREW SIZE	TORQUE - FOOT-POUNDS					
	GRADE 2		GRADE 5		GRADE 8	
	DRY	LUBE	DRY	LUBE	DRY	LUBE
1/4"	5	4	8	6	12	9
5/16"	11	8	17	13	25	18
3/8"	20	15	30	23	45	35
7/16"	30	24	50	35	70	55
1/2"	50	35	75	55	110	80
9/16"	65	50	110	80	150	110
5/8"	90	70	150	110	220	170
3/4"	100	120	260	200	380	280
7/8"	140	110	400	300	600	460
1"	220	160	580	440	900	650

This page is intentionally left blank.

PARTS

Instructions for Ordering Parts



Order from the **AUTHORIZED DEALER** in your area.

1. Always give the pertinent model and serial number.
2. Give part name, part number and the quantity required.
3. Give the correct address to where the parts are to be shipped, and the carrier if there is a preference.

Unless claims for shortages or errors are made immediately upon receipt of goods they will not be considered. Any part returns should be directed through the dealer from which they were purchased.

When broken goods are received, a full description of the damage should be made by the carrier agent on the freight bill. If this description is insisted upon, full damage can always be collected from the transportation company.

No responsibility is assumed for delay or damage to merchandise while in transit. Our responsibility ceases upon delivery of shipment to the transportation company from whom a receipt is received showing that shipment was in good condition when delivered to them, therefore, claims (if any) should be filed with the transportation company and not with New Leader Manufacturing.

If your claims are not being handled (by the transportation company) to your satisfaction, please call the Parts Manager at New Leader Manufacturing (319-363-8281) for assistance.

In the parts list the following symbols and abbreviations stand for:

- * - Not Shown
- AR – As Required
- CS – Carbon Steel
- SS – Stainless Steel

The parts listed under the different steel types (CS, 409 SS and 304 SS) are for that type of unit and do not necessarily mean the part is made of that type of steel.



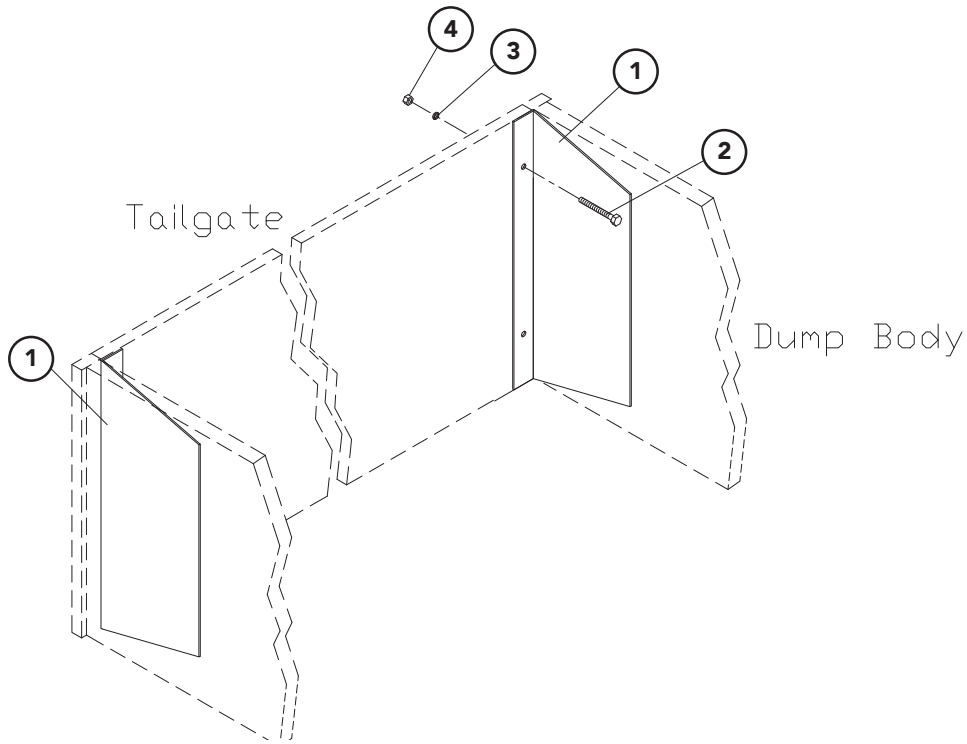

ITEM	PART NO.			DESCRIPTION	QTY
	CS	304 SS	201 SS		
	88876	88876-X1	88876	Hardware- Kit, Includes 2-4	
1	96811	96856	308505	Guard- Tailgate	2
2	20079	34860	20079	Cap Screw – 3/8 x 4	4
3	20712	36420	20712	Washer – Lock 3/8	4
4	20644	36414	20644	Nut – Hex 3/8	4

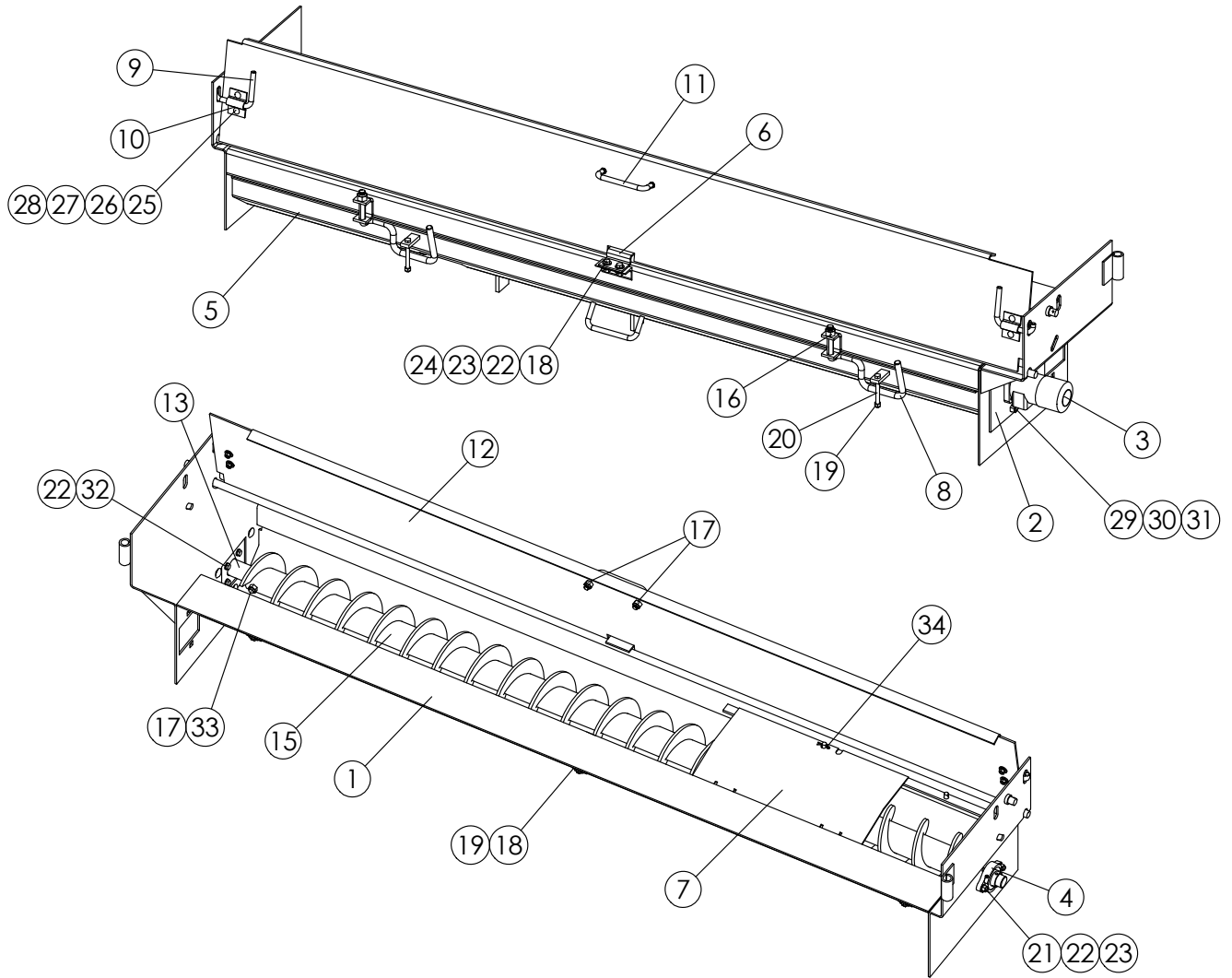

ITEM	PART NO.			DESCRIPTION	QTY
	CS	304 SS	201 SS		
1	304842	304843	308508	Frame – Wldmt Trough	1
2	96789	96850	308493	Plate – Motor Mount	1
3	37338	37338	37338	Motor – Hydraulic	1
4	96818	96818	96818	Bearing – 2-Bolt 1-1/4	1
5	96794	96860	308480	Trough – Wldmt Bottom	1
	* 300564	300565	309567	Trough – Wldmt Bottom LH Discharge	1
6	96768	96845	308496	Bracket – Cover Hinge	1
7	96767	96820	308497	Cover – Flow	1
	* 300570	300571	309570	Cover – Flow LH Discharge	1
8	96772	96831	96831	Handle – Locking	2
9	96771	96830	96830	Handle	2
10	96770	96770	96770	Bracket – Lock Cover	2



Trough - Direct Drive Continued

ITEM	PART NO.			DESCRIPTION	QTY
	CS	304 SS	201 SS		
11	96769	96829	96829	Handle – Cover	1
12	96805	96862	308481	Cover – Wldmt Top	1
13	96757	96757	96757	Shaft – Adapter	1
14	96755	96755	96755	Insert – Auger Tube	1
15	96800	96800	96800	Auger – Wldmt	1
	* 300561	300561	300561	Auger – Wldmt LH Discharge	1
16	97042	97043	97043	Nut – Lock 2-Way 5/8	2
17	20680	39016	39016	Nut – Lock 1/2	3
18	20067	36398	36398	Cap Screw – 3/8 x 1	5
19	20678	72054	72054	Nut – Lock 3/8	5
20	20077	96879	96879	Cap Screw – 3/8 x 3-1/2	2
21	20068	36399	36399	Cap Screw – 3/8 x 1-1/4	2
22	20712	36420	36420	Washer – Lock 3/8	8
23	20693	36425	36425	Washer – Flat 3/8	4
24	20644	36414	36414	Nut – Hex 3/8	4
25	20290	96880	96880	Bolt – Carriage 5/16 x 3/4	4
26	20692	36424	36424	Washer – Flat 5/16	4
27	20711	36419	36419	Washer – Lock 5/16	4
28	20643	36413	36413	Nut – Hex 5/16	4
29	96885	96886	96886	Bolt – Carriage 1/2 x 1 Short Neck	3
30	20714	36422	36422	Washer – Lock 1/2	3
31	20646	36416	36416	Nut – Hex 1/2	3
32	20065	36293	36293	Cap Screw – 3/8 x 3/4	4
33	20138-X1	20138-X1	20138-X1	Cap Screw – 1/2 x 3-1/2	1
34	40562	41779	41779	Pin – Hair	1

*- Not Shown



Trough - Gearcase Drive

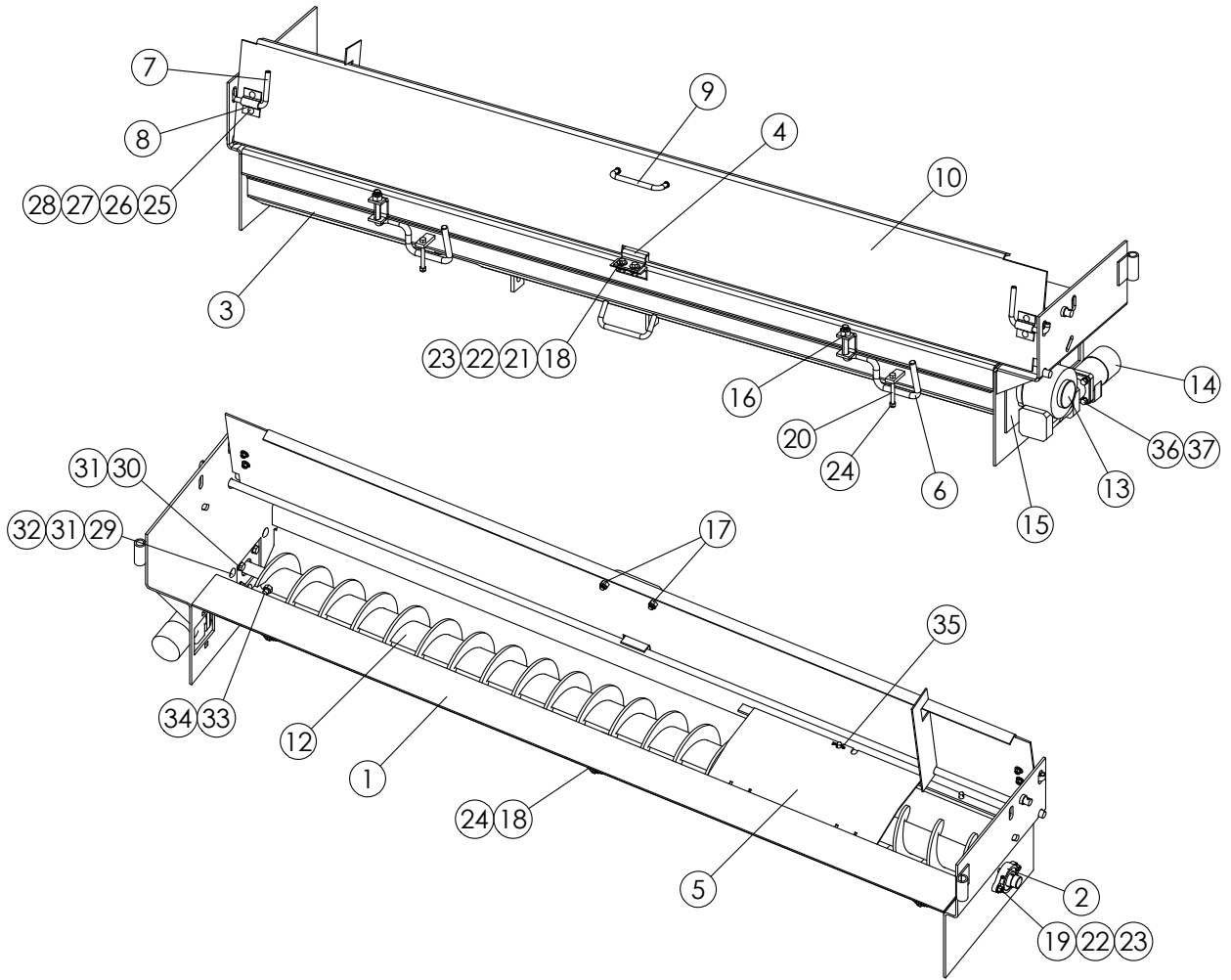

ITEM	PART NO.			DESCRIPTION	QTY
	CS	304 SS	201 SS		
1	304842	304843	308508	Frame – Wldmt Trough	1
2	96818	96818	96818	Bearing – 2-Bolt 1-1/4	1
3	96794	96860	308480	Trough – Wldmt Bottom	1
	* 300564	300565	309567	Trough – Wldmt Bottom LH Discharge	1
4	96768	96845	308496	Bracket – Cover Hinge	1
5	96767	96820	308497	Cover – Flow	1
	* 300570	300571	309570	Cover – Flow LH Discharge	1
6	96772	96831	96831	Handle- Locking	2
7	96771	96830	96830	Handle	2
8	96770	96770	96770	Bracket – Lock Cover	2
9	96769	96829	96829	Handle – Cover	1



Trough - Gearcase Drive Continued

ITEM	PART NO.			DESCRIPTION	QTY
	CS	304 SS	201 SS		
10	96805	96862	308481	Cover – Wldmt Top	1
11	96755	96755	96755	Insert – Auger Tube	1
12	96800	96800	96800	Auger – Wldmt	1
	* 300561	300561	300561	Auger – Wldmt LH Discharge	1
13	71825	71825	71825	Gearcase- Assy	1
14	70927	70927	70927	Motor – Hydraulic	1
15	96816	96853	309569	Plate – Gearcase Mount	1
16	97042	97043	97043	Nut – Lock 5/8	2
17	20680	39016	39016	Nut – Lock 1/2	2
18	20067	36398	36398	Cap Screw – 3/8 x 1	5
19	20068	36399	39399	Cap Screw – 3/8 x 1-1/4	2
20	20077	96879	96879	Cap Screw – 3/8 x 3-1/2	2
21	20693	36425	36425	Washer – Flat 3/8	4
22	20712	36420	36420	Washer – Lock 3/8	4
23	20644	36414	36414	Nut – Hex 3/8	4
24	20678	72054	72054	Nut – Lock 3/8	5
25	20290	96880	96880	Bolt – Carriage 5/16 x 3/4	4
26	20692	36424	36424	Washer – Flat 5/16	4
27	20711	36419	36419	Washer – Lock 5/16	4
28	20643	36413	36413	Nut – Hex 5/16	4
29	96885	96886	96886	Bolt – Carriage 1/2 x 1 Short Neck	3
30	20127	36401	36401	Cap Screw – 1/2 x 1	4
31	20714	36422	36422	Washer – Lock 1/2	7
32	20646	36416	36416	Nut – Hex 1/2	3
33	20138-X1	20138-X1	20138-X1	Cap Screw – 1/2 x 3-3/4	1
34	20680	20680	20680	Nut – Lock 1/2	1
35	40562	41779	41779	Pin – Hair	1
36	20067	20067	20067	Cap Screw – 3/8 x 3/4	4
37	20712	20712	20712	Washer – Lock 3/8	4
38	* 97040	97041	97041	Spacer – Plate Gear Case	1

*- Not Shown

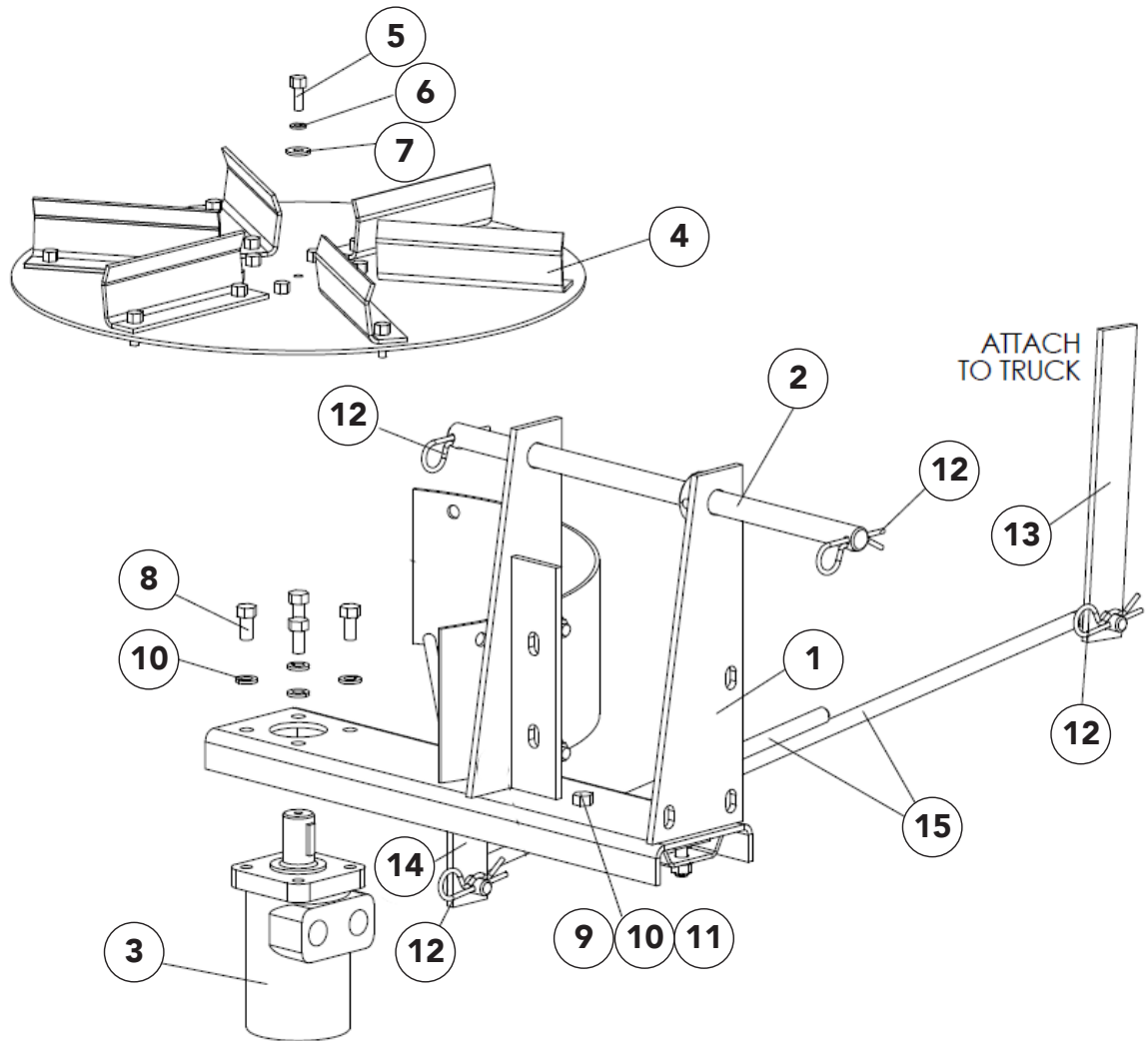

ITEM	PART NO.			DESCRIPTION	QTY
	CS	304 SS	201 SS		
	96815	96867	96867	Spinner – Kit Steel Disc (includes 1, 3-8)	
	96803	96866	96866	Spinner – Kit Poly Disc (includes 1, 3-8)	
1	96763	96859	96859	Frame – Wldmt Spinner	1
2	96758	96842	96842	Rod – Hinge	1
3	37336	37336	37336	Motor – Hydraulic	11
4	73466	73466	73466	Disc – Assy Steel Spinner	1
	73467	73467	73467	Disc – Steel	1
	2240	2240	2240	Fin – Blade	6
	74122	74122	74122	Hub – Disc	1
	20003	20003	20003	Cap Screw – 1/4 x 3/4	12
	20004	20004	20004	Cap Screw – 1/4 x 7/8	6



Spinner Continued

ITEM	PART NO.			DESCRIPTION	QTY
	CS	304 SS	201 SS		
	20676	20676	20676	Nut – Lock 1/4	18
* 78780-X1	* 78780-X1	*78780-X1		Disc – Assy Poly Spinner	1
	34852	34852	34852	Disc – Urethane	1
	74122	74122	74122	Hub – Disc	1
	39178	39178	39178	Plate – Mount Spinner	1
	20007	20007	20007	Cap Screw – 1/4 x 1-1/2	6
	21423	21423	21423	Washer – Flat 1/4	6
	20676	20676	20676	Nut – Lock 1/4	6
5	36393	36393	36393	Cap Screw – 1/4 x 3/4	1
6	36423	36423	36423	Washer – Flat 1/4	1
7	36418	36418	36418	Washer – Lock 1/4	1
8	20065	36293	36293	Cap Screw – 3/8 x 3/4	4
9	20068	36399	36399	Cap Screw – 3/8 x 1-1/4	2
10	20712	36420	36420	Washer – Lock 3/8	6
11	20644	36414	36414	Nut – Hex 3/8	2
12	40576	36429	36429	Pin – Hair	4
13	96756	96841	308504	Bracket – Frame	1
14	96754	96840	308503	Angle – Mounting	1
15	96752	96858	96858	Rod – Wldmt Linkage	2
16	*32996	*32996-X1	*32996-X1	Panel - Baffle Curved (mounts to back-side of fixed baffle)	1
17	*36395	*36395	*36395	Cap Screw - 1/4-20NC x 1 SS	2
18	*32445	*32445	*32445	Nut - Wing 1/4-20NC SS	2
19	*36423	*36423	*36423	Washer - Flat 1/4 SS	2

*- Not Shown

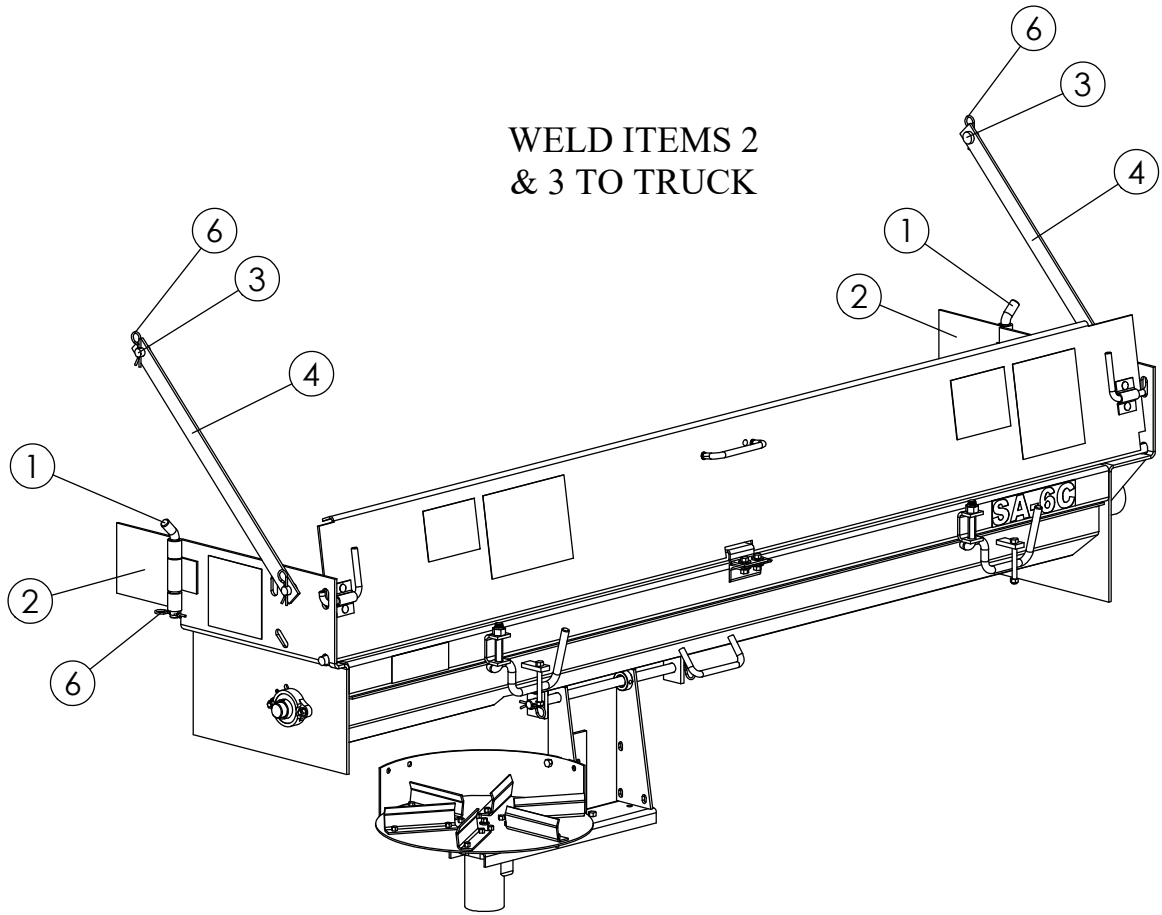

WELD ITEMS 2
& 3 TO TRUCK

ITEM	PART NO.		DESCRIPTION	QTY
	CS	304 SS		
1	96764	96827	Pin – Hinge	2
2	96877	96878	Plate – Wldmt	2
3	96780	96825	Boss	2
4	96762	96844	Brace – Mounting	2
5	96760	96833	Clamp – Hose	2
6	40576	36429	Pin – Hair	6

Mounting - Quick Disconnect

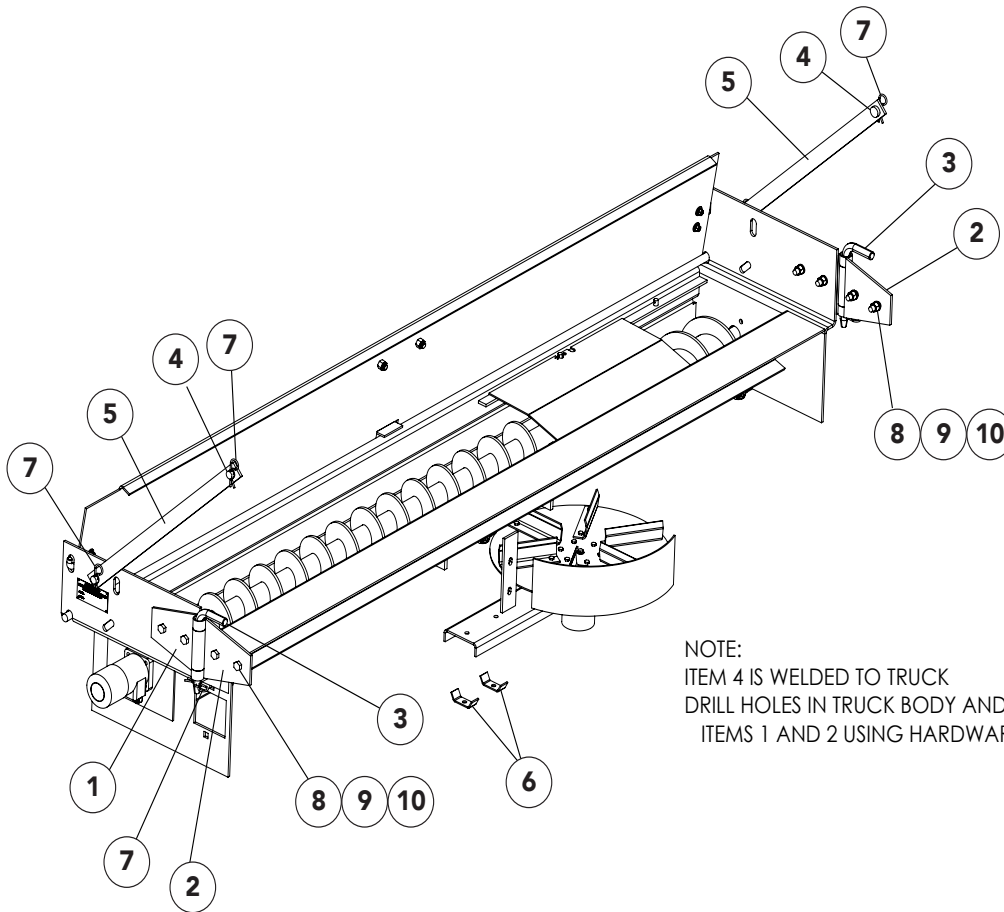

NOTE:
ITEM 4 IS WELDED TO TRUCK
DRILL HOLES IN TRUCK BODY AND SA-6C TO MOUNT
ITEMS 1 AND 2 USING HARDWARE ITEMS 8, 9, AND 10

ITEM	PART NO.			DESCRIPTION	QTY
	CS	304 SS	201 SS		
1	23244	23244-X1	308483	Mount – Quick Disconnect Male	2
2	23236	23236-X1	308484	Mount – Quick Disconnect Female	2
3	23248	23248-X1	23248-X1	Rod – Lock Pin	2
4	96780	96825	96825	Boss	2
5	96762	96844	96844	Brace – Mounting	2
6	96760	96833	96833	Clamp – Hose	2
7	40576	36429	36429	Pin – Hair	6
8	20129	36539	36539	Cap Screw – 1/2-13 x 1-1/2	8
9	20714	36422	36422	Washer – Lock 1/2	AR
10	20646	36416	36416	Nut – Hex 1/2	AR

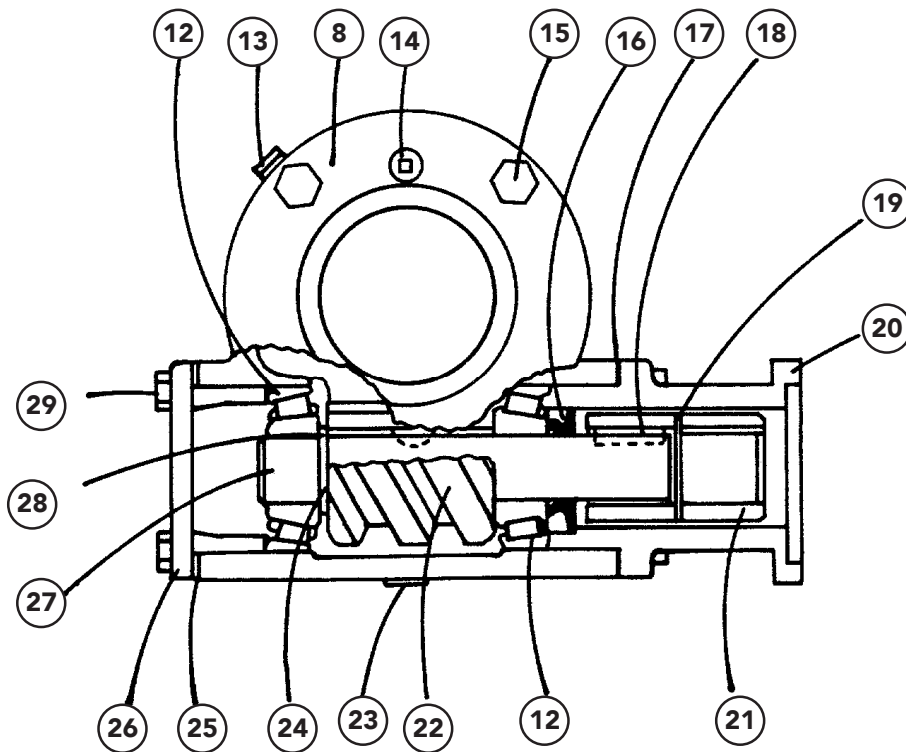
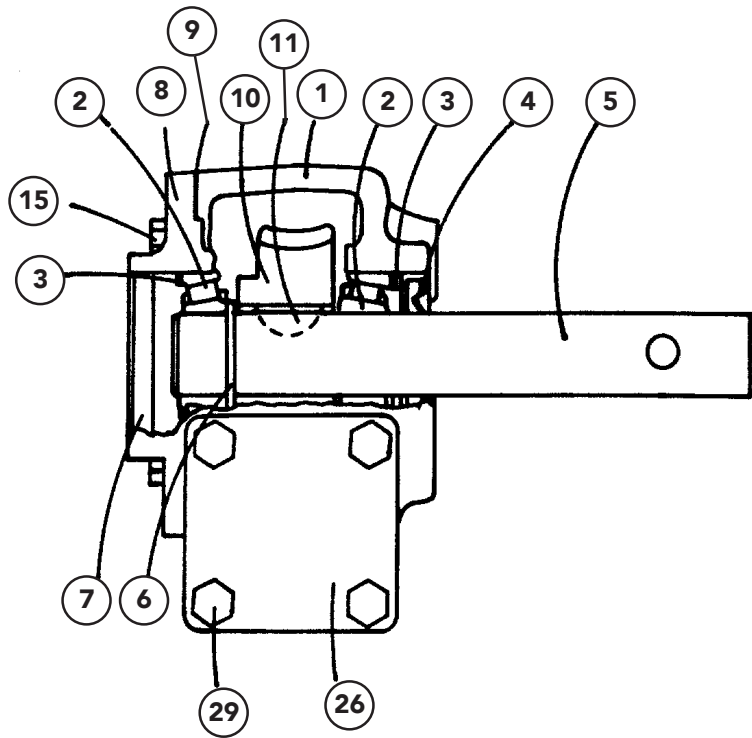

GearCase Continued

<u>ITEM</u>	<u>PART NO.</u>	<u>DESCRIPTION</u>	<u>QTY</u>
	71825	Gear Case Assy	1
1	58985	Housing	1
2	24230	Bearing – Cone	2
	24225	Bearing – Cup	2
3	22832	Ring – Snap	2
4	22831	Seal – Output	1
5	58987	Shaft – Output	1
6	24231	Ring – Snap	1
7	22839	Cap	1
8	22824	Cover	1
9	22834	Gasket – Cover	1
10	22825	Gear – Worm	1
11	58988	Key – Woodruff	1
12	22840	Bearing – Cone	2
	24225	Bearing – Cup	2
13	8621	Plug – Vent	1
14	6031	Plug – Level	1
15	20065	Cap Screw- 3/8 x 3/4	4
16	71458	Seal – Input	1
17	58989	Gasket	1
18	34995	Key	1
19	58986	Pin – Roll	1
20	83585	Mount – Motor	1
21	71105	Coupling	1
22	22826	Worm	1
23	6293	Plug – Drain	1
24	6089	Ring – Snap	1
25	58989	Gasket	1
26	71454	End	1
27	71456	Shaft – Input	1
28	24234	Key – Woodruff	1
29	20066	Cap Screw- 3/8 x 7/8	8
30	22835	Shim	AR

AR- As Required



<u>ITEM</u>	<u>PART NO.</u>	<u>DESCRIPTION</u>	<u>QTY</u>
1	37338	Motor – Hydraulic	1

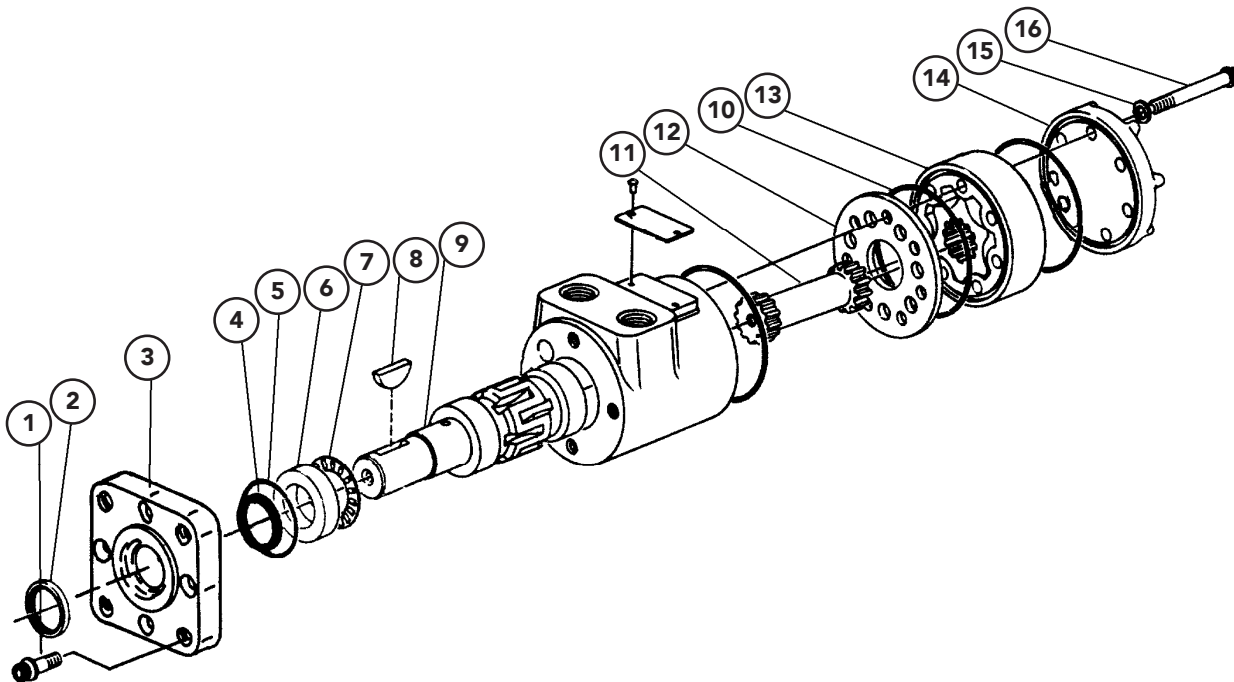

ITEM	PART NO.	DESCRIPTION	QTY
	37336	Motor – Hydraulic	
1	30665	Cap Screw	4
2	37382	Seal	1
3	37383	Flange – Mounting 4 Bolt	1
4	37378	Seal	1
5	37379	Seal – O-Ring	1
6	37385	Race – Bearing	1
7	37401	Bearing – Thrust Needle	1
8	3065	Key – Woodruff	1
9	37387	Shaft – Output	1
10	37380	Seal – O-Ring	3
11	16945	Drive	1
12	37388	Plate – Spacer	1
13	37389	Gerotor	1
14	37400	Cap – End	1
15	37381	Washer – Seal	7
16	16931	Cap Screw	7
17	* 22068	Seal – O-Ring	1
	37352	Kit – Seal, Includes Items 2,4,5,9,14	

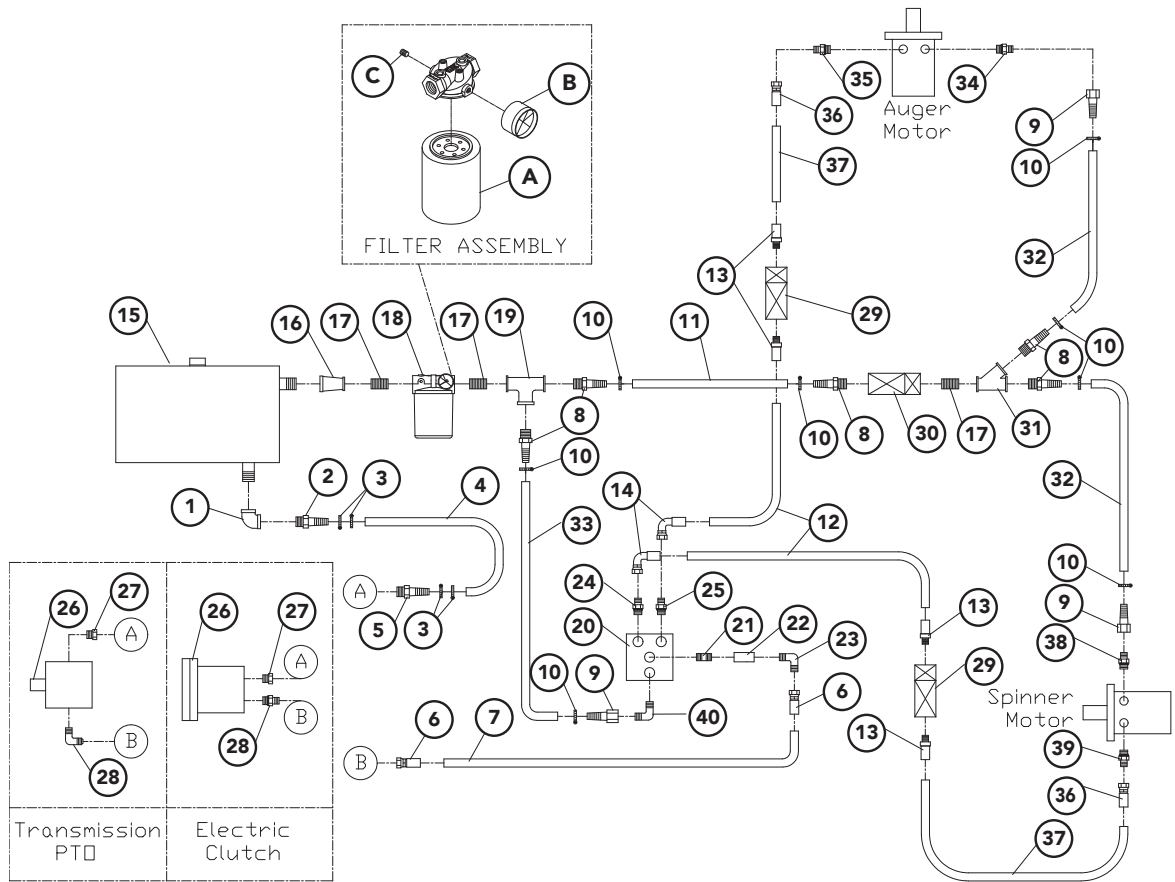

ITEM	PART NO.	DESCRIPTION	QTY
1	6011	Elbow- Pipe, 90°	1
2	16582	End- Hose	1
3	6335	Clamp- Hose	4
4	23184-72	Hose- Suction (Trans. PTO)	1
	23184-144	Hose- Suction (Electric Clutch)	1
5	16572	End- Hose (Trans. PTO)	1
	16582	End- Hose (Electric Clutch)	1
6	56508	End- Hose	2
7	56459-72	Hose- Hydraulic (Trans. PTO)	1
	56459-120	Hose- Hydraulic (Electric Clutch)	1
8	22425	End- Hose	5
9	11424	End- hose	3
10	22381	Clamp- Hose	8
11	16529-144	Hose- Return	1
12	56453-144	Hose- Hydraulic	2
13	31599	End- Hose	4
14	56485	End- Hose, 90°	2



Hydraulic System Continued

<u>ITEM</u>	<u>PART NO.</u>	<u>DESCRIPTION</u>	<u>QTY</u>
15	39796	Reservoir – Hydraulic Wldmt	1
	* 20069	Cap Screw- 3/8 x 1 1/2	4
	* 20693	Washer- Flat, 3/8	4
	* 20712	Washer- Lock, 3/8	4
	* 20644	Nut- Hex, 3/8	4
16	8809	Coupling- Pipe	1
17	6026	Nipple- Pipe	3
18	30743	Filter- Oil	1
A	39934	Filter	1
B	43534	Indicator- Service	1
C	21835	Plug	1
19	6020	Tee- Pipe	1
20	310650	Valve- Control	1
21	29788	Fitting 12-12 S1040-30 Non-Standard	1
22	29817	Fitting- 12-12 070101	1
23	34709	Fitting- 90° 12-12 070221	2
24	29771	Fitting- 8-10 070120	1
25	29770	Fitting- 8-8 070120	1
26	34569	Pump- Hydraulic Assy (Electric Clutch)	1
	24516	Pump- Hydraulic Assy (Trans. PTO)	1
27	22018	Adapter (Electric Clutch)	1
	22016	Adapter (Trans. PTO)	1
28	29835	Adapter (Electric Clutch)	1
	29764	Adapter- 90° (Trans. PTO)	1
29	* 16322	Coupling- Pipe (Standard)	2
	22332	Disconnect- Quick, 1/2" (Optional)	2
30	* 6003	Coupling- Pipe (Standard)	1
	71185	Disconnect- Quick, 3/4" (Optional)	1
31	22220	Pipe- Y	1
32	16529-120	Hose- Return	1
33	16529-96	Hose- Return	1
34	29753	Adapter- Straight	1
35	29771	Adapter- Connector	1
36	31598	End- Hose	2
37	56453-120	Hose- Hydraulic	1
38	29771	Adapter- Straight	1
39	29753	Adapter- Straight	1
40	29747	Fitting- 12-12 070220	1

* - Not Shown



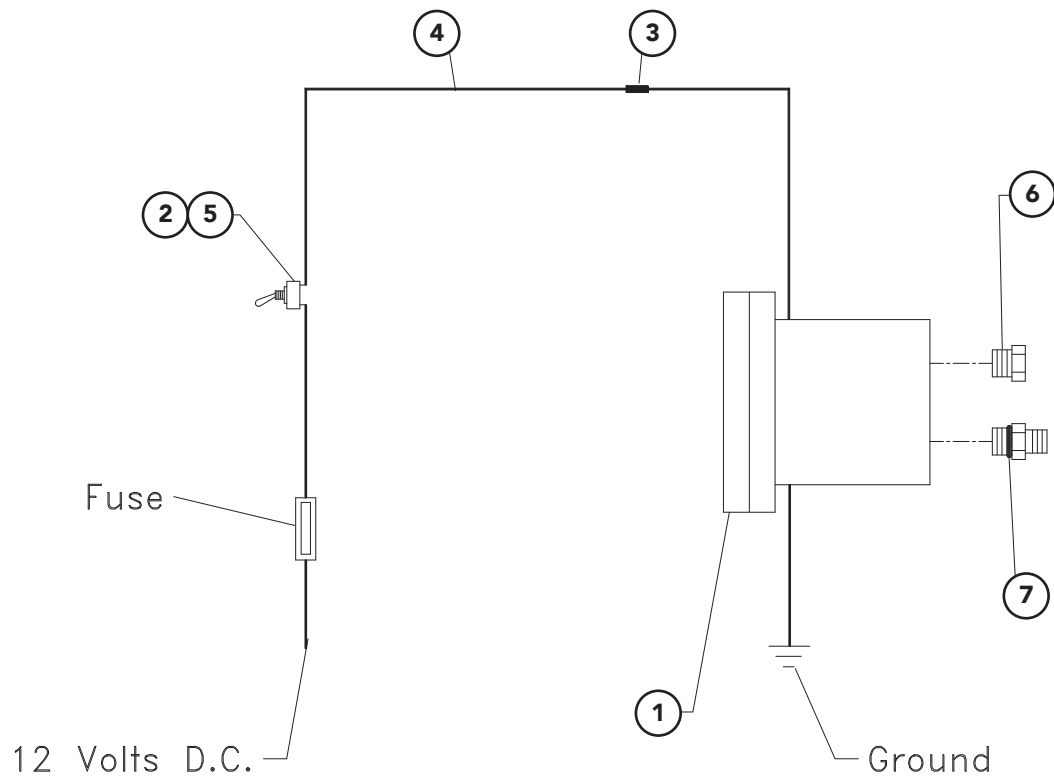

ITEM	PART NO.	DESCRIPTION	QTY
	71196	Kit – Pump w/ Electric Clutch	
1	34569	Pump – Hydraulic with Elec. Clutch Assy	1
	34577	Pump – Hydraulic	1
	34570	Clutch – Electric	1
	34571	Bracket – Mounting	1
2	21679	Terminal – Spade	1
3	6549	Connector – Butt	1
4	21580-120	Wire – Black, 14 Ga.	1
5	21681	Switch – Toggle	1
6	22018	Adapter	1
7	29835	Adapter	1

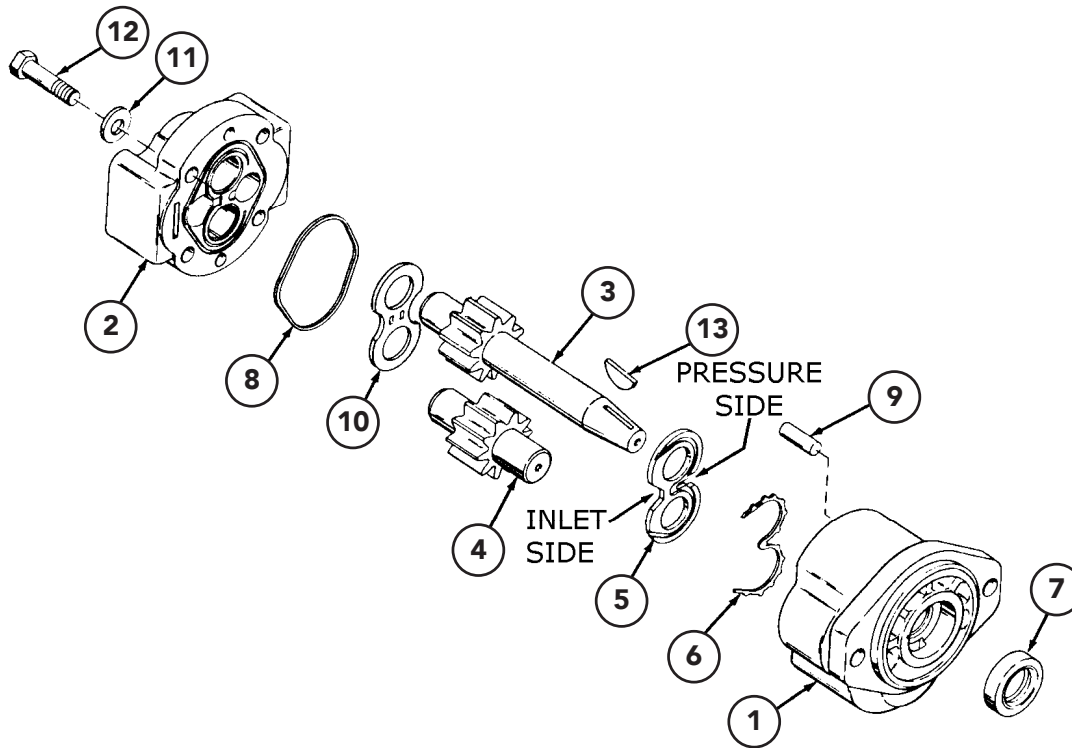

ITEM	PART NO.	DESCRIPTION	QTY
	34577	Pump Assy	
1	34546	Body – Pump Assy	1
2	34549	Cover Assy	1
3	34564	Gear – Drive	1
4	34566	Gear – Driven	1
5	34554	Plate – Wear	1
6	34555	Seal – Pressure Loading	1
7	34556	Seal – Shaft	1
8	34557	Ring – Square Cut	1
9	34558	Pin – Dowel	1
10	34559	Plate – Thrust	1
11	34560	Washer	4
12	34561	Cap Screw	4
13	34562	Key – Woodruff	1
	34563	Kit – Seal, Includes Items 6- 8	

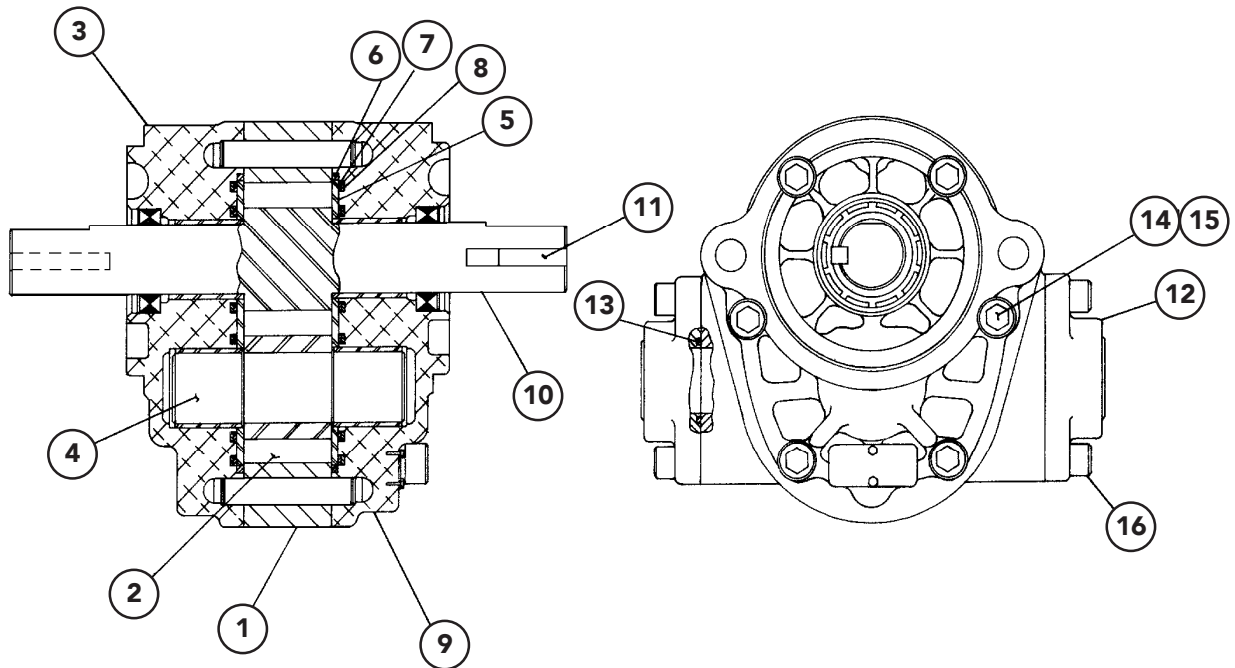

ITEM	PART NO.	DESCRIPTION	QTY
	24516	Pump – Hydraulic Assy	
1	5676	Housing – Gear	1
2	5680	Pin – Dowel	2
3	58621	Plate – End	1
4	58622	Gear – Idler	1
5	5665	Plate – Wear	2
6	5678	Seal – Ring	2
7	5666	Washer – Backup	2
8	5677	Seal – Preload	2
9	58623	Plate – End	1
10	5682	Shaft – Drive	1
11	6137	Key – Square	1
12	58624	Flange	2
13	5685	O-Ring	2
14	5683	Bolt – Socket Head	6
15	58625	Washer	6
16	58626	Bolt – Socket Head	4
	3904	Kit – Seal, Includes Items 5-8, 11, 13	



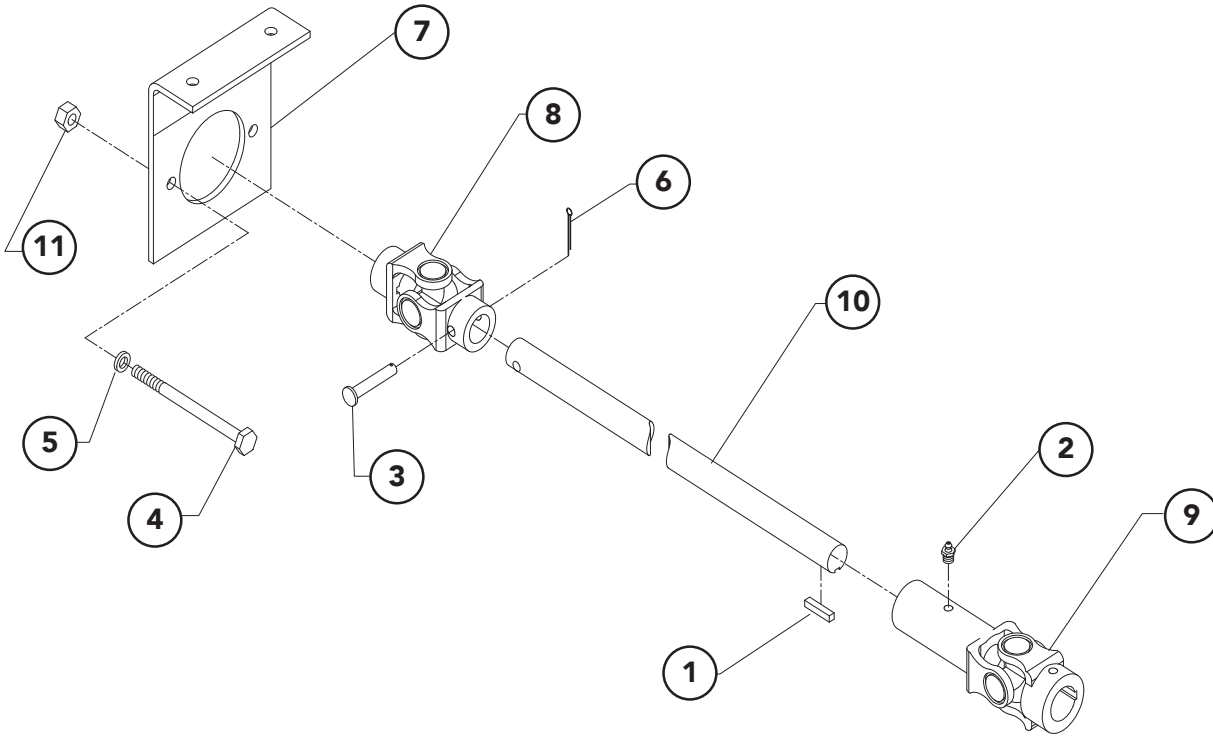

ITEM	PART NO.	DESCRIPTION	QTY
1	2211	Key - Square	1
2	6069	Zerk - Grease	1
3	6123	Pin - Shear	1
4	20085	Cap Screw- 3/8 x 5 1/2	2
5	20712	Washer - Lock 3/8	2
6	20817	Pin - Cotter	1
7	22337	Bracket - Mounting Wldmt	1
8	22465	U-Joint	1
9	56745	U-Joint	1
10	17932	Shaft - Drive	1
11	20644	Nut - Hex 3/8	2

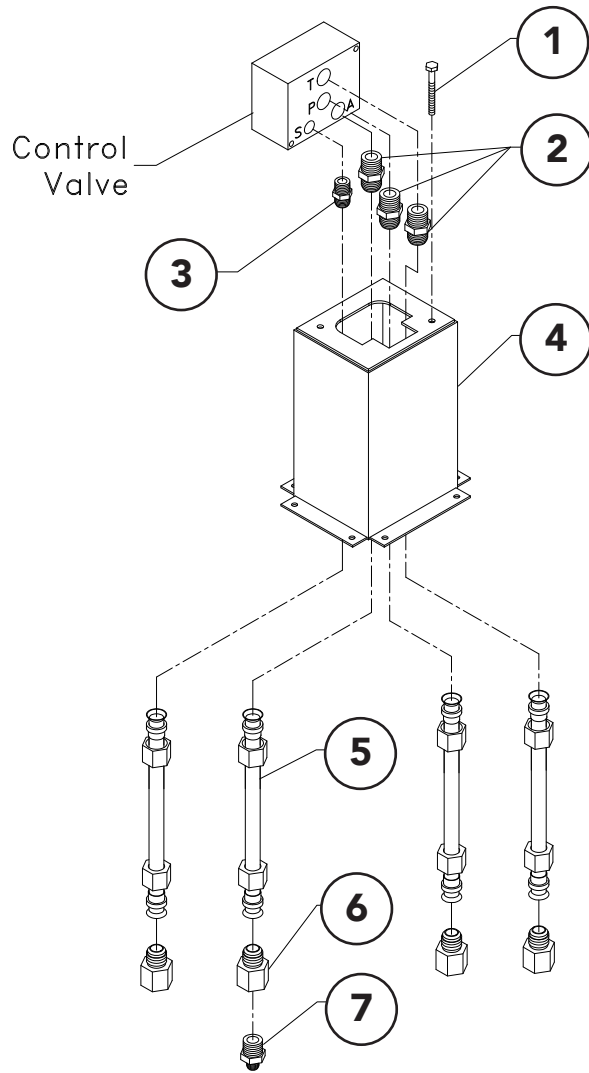

T - TANK
 P - PUMP PRESSURE
 S - SPINNER
 A - AUGER/CONVEYOR

ITEM	PART NO.	DESCRIPTION	QTY
1	20013	Cap Screw- 1/4 x 3	2
2	29752	Adapter	3
3	29784	Adapter	1
4	36803	Mount – Valve Wldmt	1
5	36800	Tube – Hydraulic	4
6	29799	Adapter – Bushing	4
7	29808	Adapter	1

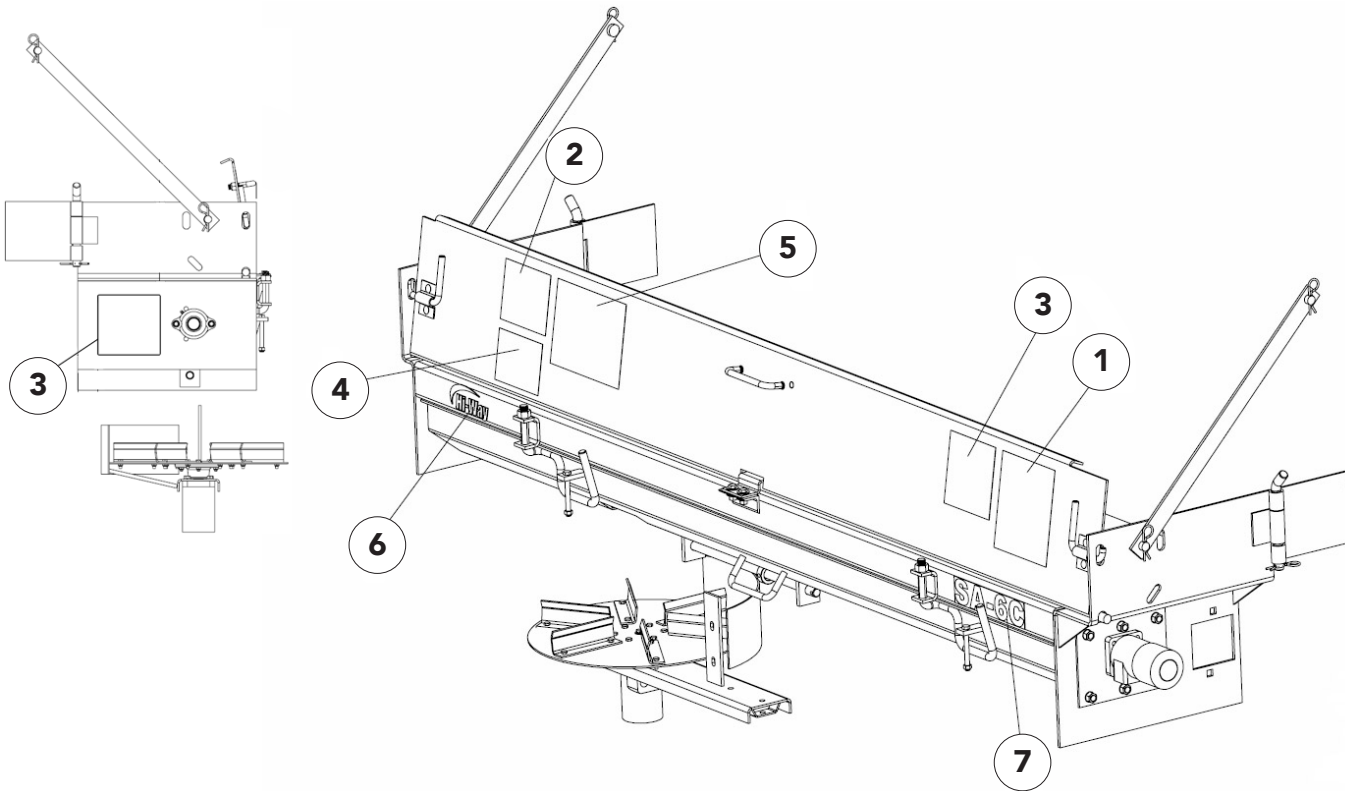

ITEM	PART NO.	DESCRIPTION	QTY
1	150034	Decal – Caution Operation & Maintenance	1
2	321	Decal – Caution Hazardous Material	1
3	55997	Decal – Danger Stay Out of Box	2
4	55631	Decal – Warning Moving Part	1
5	368	Decal – Danger Flying Material	1
6	83628	Decal – HI-WAY Small	1
7	96884	Decal – SA-6C	1
8	*37285	Serial Plate- HECO	1
9	*6276	Screw	4
10	*8664	Decal- Important Keep Valve Open (Hydraulic Tank)	1
11	*8665	Decal- Important Hydraulic Oil Only	1
12	*39378	Decal- Change Filter Element	1
*- Not Shown			

This page is intentionally left blank.