



NEWLEADER.COM

   
Go ahead, follow us.

New Leader®
Spinner Spreaders
AGCO



ABOUT OUR EXCLUSIVE PARTNERSHIP WITH AGCO

New Leader's partnership with AGCO started in 1960. Our exclusive partnership gives us the ability to customize our spreaders to work seamlessly with designated AGCO chassis models to maximize reliability and service life.



WHO WE ARE

Building the best since 1939, New Leader Manufacturing is family owned and operated. Our business is built on honesty and integrity. We have a passion for what we do and firmly believe that we can make a better tomorrow by building the best today.

New Leader Manufacturing was founded with a singular focus: **to build the best equipment possible.** Whether that's spreading salt to deice a highway or nutrients to fertilize a crop, we've focused our business around making sure you have the tools to apply precisely what you need, when you need it.

Leading Change

As leaders, we never stop moving forward. From designing and building equipment, to helping our customers, continuing to grow a positive and sustainable workplace, and giving back to our community, we believe in leading change.

In 2018 we opened our first international facility, New Leader Indústria e Comércio de Máquinas Agrícolas Ltda. In 2021, we grew into our new manufacturing facility and office location in Indaiatuba, São Paulo, Brazil.

Spreading Good

Giving back has always been an important value of the company. Through our Spreading Good program, New Leader is dedicated to improving the lives of others. With each NL5000 G5 spreader sold, we help provide clean water to rural African communities.

Supporting people, organizations, and causes that are working to spread good is what it means to be a leader.

We believe in simple things. Like safety, service, and quality. We believe in people. Our people got us here and our people will always be our top priority.



©2021

Owners Matt Rissi and Rocki Shepard

NL4500G4 Edge

RoGator 900

SPREAD ACCURACY

The NL4500G4 Edge is a 253 cu ft spinner spreader installed on the RoGator 900 series chassis.

AG LIME COMPATIBLE

The NL4500G4 Edge single bin has the ability to spread Ag Lime, as well as fertilizer.

SINGLE BIN

The single bin is available in 409 painted stainless steel. A removable end gate, inverted V, and electric oiler are included.

Dimensions	<i>Without side boards</i>		<i>With side boards</i>	
	Imperial	Metric	Imperial	Metric
Length	12 FT	3.66 M	12 FT	3.66 M
Width	102 IN	259 CM	102 IN	259 CM
Height	60 IN	152.4 CM	69 IN	175.2 CM
Weight	3,800 LBS	1,542 KG	4,100 LBS	1,860 KG
Single Bin Capacity	253 CU FT	7.16 CU M	333 CU FT	9.43 CU M
	12" feedgate for lime & fertilizer capabilities		5" feedgate for fertilizer only capabilities	



Without side boards



With side boards

MULTAPPLIER™

The MultiApplier allows for two separate materials to be spread simultaneously and features a 24-inch wide #4 belt-over-chain conveyor with 409 stainless steel links. The direct-driven conveyor is also controlled independently enabling the delivery of material at variable rates through the adjustable gate at the rear of the hopper body. The hillside divider improves material placement on the spinner for a more effective spread pattern.

MultApplier Capacity	Imperial	Metric
Bin 1	195 CU FT	5.52 CU M
MultApplier Bin	115 CU FT	3.25 CU M
Total Capacity	310 CU FT	8.77 CU M

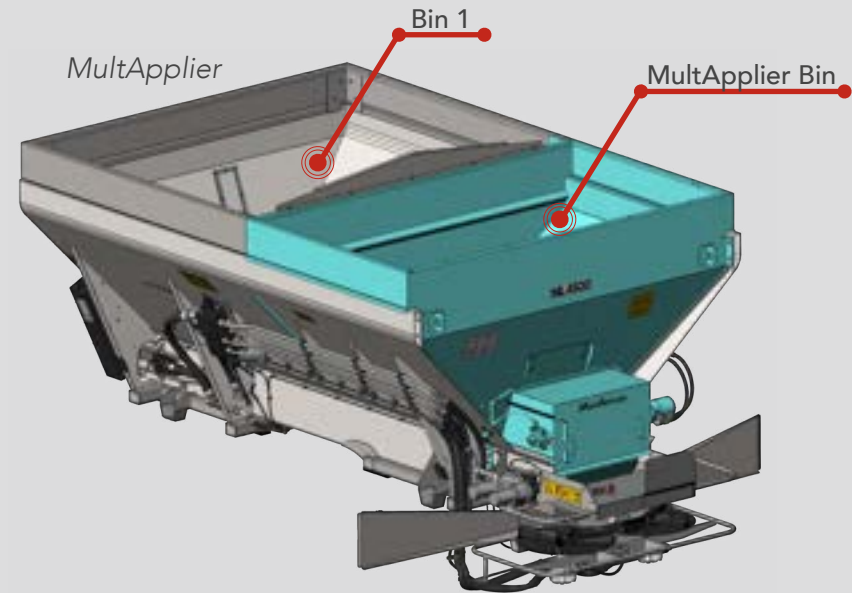

MULTIBIN™

Inserting the MultiBin will convert the spreader to 4 bins, which can be used independently or together for straight and variable rate applications. Sensors are located in all bins to warn when materials are low. The MultiBin also comes equipped with an upper and lower material divider which improves material placement on the spinner for a more effective spread pattern.

MultiBin Capacity	Imperial	Metric
Bin 1	137 CU FT	3.8 CU M
Bin 2	139 CU FT	3.94 CU M
MicroBin 3	23 CU FT	0.65 CU M
MicroBin 4	21 CU FT	0.59 CU M
Total Capacity	320 CU FT	8.98 CU M

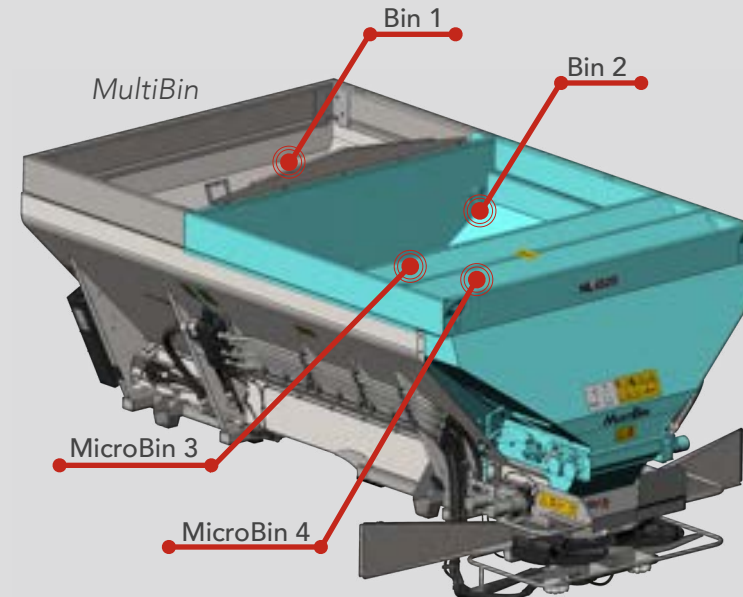

NL5000 G5

RoGator 900

UNMATCHED G5 TECHNOLOGY

The NL5000G5 spinner spreader is installed on a RoGator 900 chassis. The G5 variable rate dry nutrient applicator can help you meet the demands of the prescription nutrient programs. By using the G5 spinner technology and leveraging the conveyor speed adjustments, operators can reduce overlap, decrease nutrient waste, and ensure nutrients are placed only where they need them, not where they don't.

AG LIME COMPATIBLE

Spread Ag Lime using the 253 cu ft, single bin NL5000G5 with the 12-in feedgate height.

SINGLE BIN

The single bin is available in 409 painted stainless steel. A removable end gate, inverted V, and electric oiler are included.

Dimensions	Without side boards		With side boards	
	Imperial	Metric	Imperial	Metric
Length	12.0 FT	3.66 M	12.0 FT	3.66 M
Width	102 IN	259 CM	102 IN	259 CM
Height	59 IN	149.8 CM	69 IN	175.2 CM
Weight	4,200 LBS	1,905 KG	4,500 LBS	2,041 KG
Single Bin Capacity	253 CU FT	7.16 CU M	333 CU FT	9.43 CU M
	12" feedgate for lime & fertilizer capabilities		5" feedgate for fertilizer only capabilities	

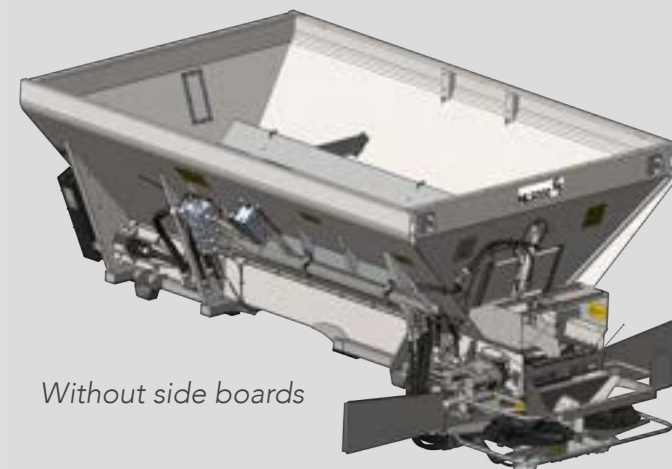

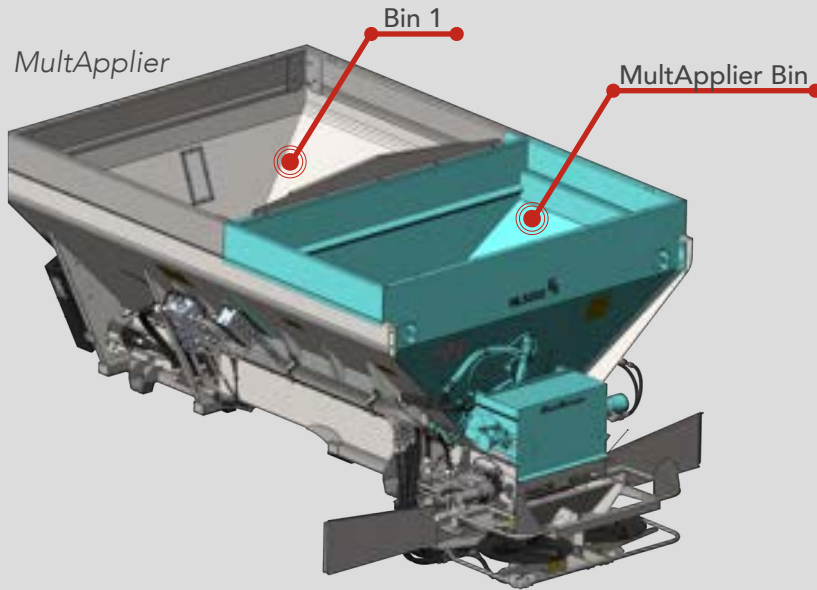

MULTAPPLIER™

The MultApplier allows for two separate materials to be spread simultaneously and features a 24-inch wide #4 belt-over-chain conveyor with 409 stainless steel links. The direct-driven conveyor is also controlled independently enabling the delivery of material at variable rates through the adjustable gate at the rear of the hopper body. The hillside divider improves material placement on the spinner for a more effective spread pattern.

MultApplier Capacity	Imperial	Metric
Bin 1	195 CU FT	5.52 CU M
MultApplier Bin	115 CU FT	3.25 CU M
Total Capacity	310 CU FT	8.77 CU M

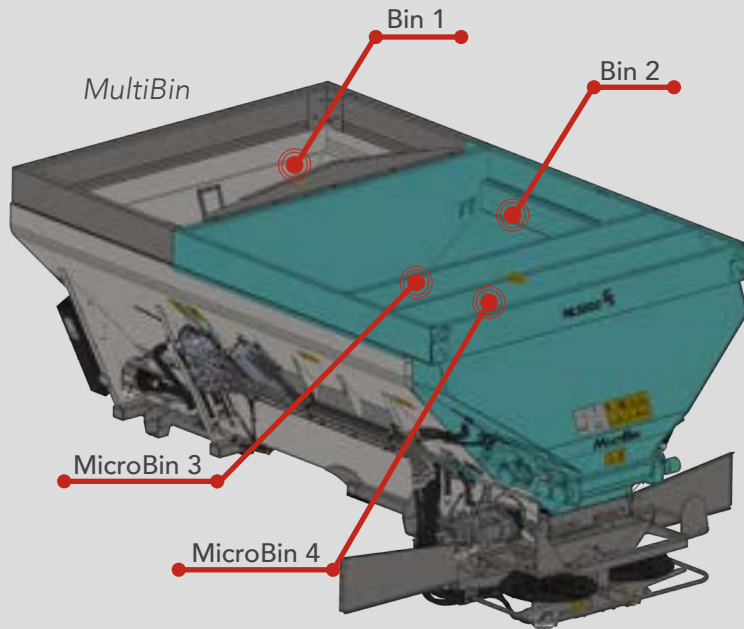

MULTIBIN™

Inserting the MultiBin will convert the spreader to 4 bins, which can be used independently or together for straight and variable rate applications. Sensors are located in all bins to warn when materials are low. The MultiBin also comes equipped with an upper and lower material divider which improves material placement on the spinner for a more effective spread pattern.

MultiBin Capacity	Imperial	Metric
Bin 1	137 CU FT	3.80 CU M
Bin 2	139 CU FT	3.94 CU M
MicroBin 3	23 CU FT	0.65 CU M
MicroBin 4	21 CU FT	0.59 CU M
Total Capacity	320 CU FT	8.98 CU M

NL4500G4 Edge

TerraGator

SPREAD ACCURACY

The NL4500G4 Edge is a 298 cu ft spinner spreader installed on the TerraGator C series chassis. Available in 14 ft and 15 ft lengths, the NL4500G4 has options and provides performance that pays.

AG LIME COMPATIBLE

The NL4500 G4 Edge single bin has the ability to spread Ag Lime, as well as fertilizer.

SINGLE BIN

The single bin is available in 409 painted stainless steel. A removable end gate, inverted V, and electric oiler are included.



Dimensions	14 FT		15 FT	
	Imperial	Metric	Imperial	Metric
Length	14 FT	4.27 M	15 FT	4.57 M
Width	102 IN	259 CM	102 IN	259 CM
Height	60 IN	152.4 CM	60 IN	152.4 CM
Weight	4,800 LBS	2,177 KG	5,000 LBS	2,268 KG
Single Bin Capacity	298 CU FT	8.4 CU M	321 CU FT	9.1 CU M

MULTAPPLIER™

The MultiApplier allows for two separate materials to be spread simultaneously and features a 24-inch wide #4 belt-over-chain conveyor with 409 stainless steel links. The direct-driven conveyor is also controlled independently enabling the delivery of material at variable rates through the adjustable gate at the rear of the hopper body. The hillside divider improves material placement on the spinner for a more effective spread pattern.

MultiApplier Capacity	Imperial	Metric
Bin 1	195 CU FT	5.52 CU M
MultiApplier Bin	161 CU FT	4.60 CU M
Total Capacity	356 CU FT	10.12 CU M

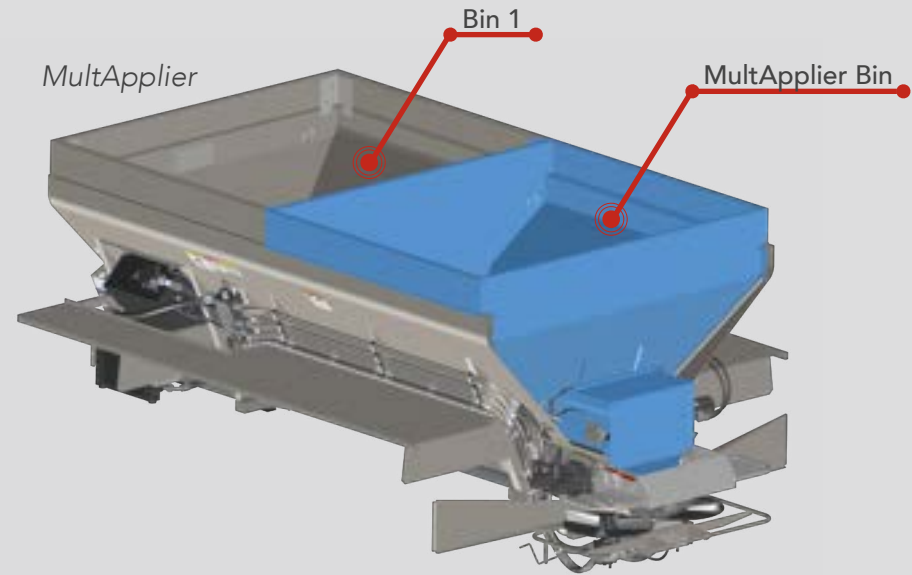

MULTIBIN™

Inserting the MultiBin will convert the spreader to 4 bins, which can be used independently or together for straight and variable rate applications. Sensors are located in all bins to warn when materials are low. The MultiBin also comes equipped with an upper and lower material divider which improves material placement on the spinner for a more effective spread pattern.

MultiBin Capacity	Imperial	Metric
Bin 1	195 CU FT	5.52 CU M
Bin 2	139 CU FT	3.94 CU M
MicroBin 3	23 CU FT	0.65 CU M
MicroBin 4	21 CU FT	0.59 CU M
Total Capacity	378 CU FT	10.70 CU M

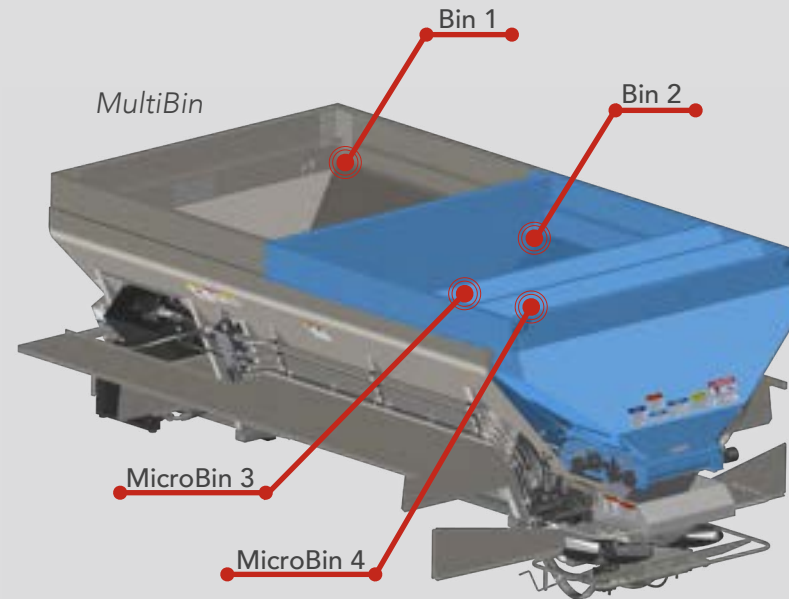

NL5000 G5

TerraGator

UNMATCHED G5 TECHNOLOGY

The NL5000 G5 is a 298 cu ft NL5000 G5 spinner spreader installed on a TerraGator chassis. The G5 variable rate dry nutrient applicator, can help you meet the demands of these prescription nutrient programs. By using the G5 spinner technology and leveraging the conveyor speed adjustments, operators can reduce overlap, decrease nutrient waste, and ensure nutrients are placed only where they need them, not where they don't.

AG LIME COMPATIBLE

The NL5000 G5 single bin has the ability to spread Ag Lime, as well as fertilizer.

SINGLE BIN

The single bin is available in 409 painted stainless steel. A removable end gate, inverted V, and electric oiler are included.

Dimensions	Imperial	Metric
Length	14.0 FT	4.27 M
Width	102 IN	259 CM
Height	59 IN	174.7 CM
Weight	5,100 LBS	2,313 KG
Single Bin Capacity	298 CU FT	8.44 CU M



MULTAPPLIER™

The MultiApplier allows for two separate materials to be spread simultaneously and features a 24-inch wide #4 belt-over-chain conveyor with 409 stainless steel links. The direct-driven conveyor is also controlled independently enabling the delivery of material at variable rates through the adjustable gate at the rear of the hopper body. The hillside divider improves material placement on the spinner for a more effective spread pattern.

MultiApplier Capacity	Imperial	Metric
Bin 1	195 CU FT	5.52 CU M
MultiApplier Bin	161 CU FT	4.60 CU M
Total Capacity	356 CU FT	10.12 CU M

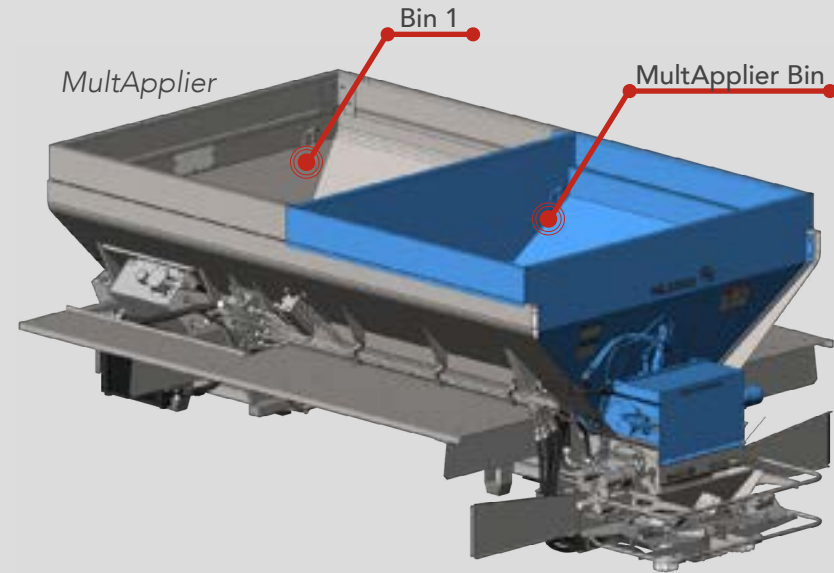

MULTIBIN™

Inserting the MultiBin will convert the spreader to 4 bins, which can be used independently or together for straight and variable rate applications. Sensors are located in all bins to warn when materials are low. The MultiBin also comes equipped with an upper and lower material divider which improves material placement on the spinner for a more effective spread pattern.

MultiBin Capacity	Imperial	Metric
Bin 1	195 CU FT	5.52 CU M
Bin 2	139 CU FT	3.94 CU M
MicroBin 3	23 CU FT	0.65 CU M
MicroBin 4	21 CU FT	0.59 CU M
Total Capacity	378 CU FT	10.70 CU M

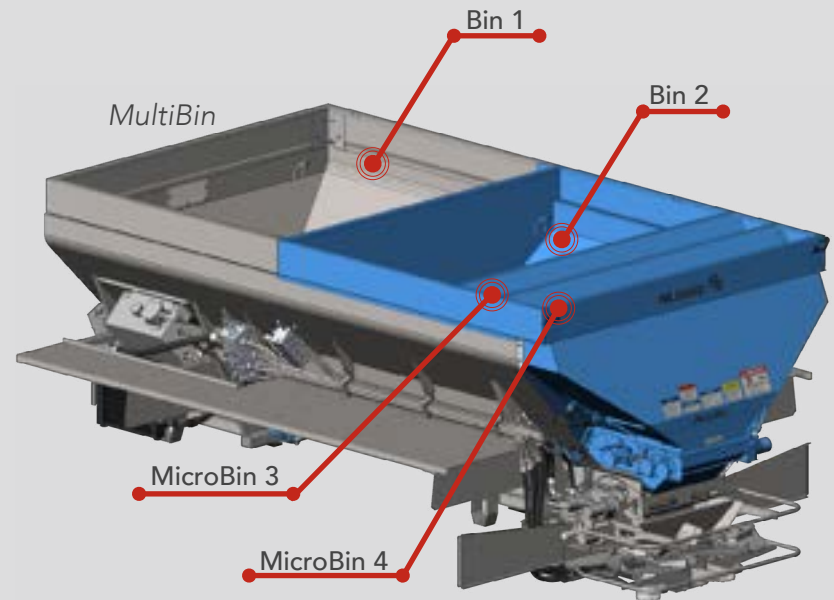

UNMATCHED G5 TECHNOLOGY

The NL5000 G5 sets itself apart by using patented G5 spinner technology proven to spread products fast, wide, and more consistently. Now you have access to technology that gives you increased accuracy by shifting the spinner frame fore/aft and left/right to control the swath, altering where the product falls onto the spinners while in motion. This, along with conveyor speed adjustments, allows for pinpoint accuracy.

The G5 spinner control gives 16-section swath width control while adjusting conveyor speed to maintain accurate application rates. This gives you the ability to significantly reduce overlap and apply nutrients to the right place.





16-SECTION SWATH WIDTH CONTROL

By automatically shifting the fan frame fore and aft, and left and right when applying nutrients on a field, operators are able to achieve up to 16-section swath width control.



LAST PASS CONTROL

Last pass control allows for reduced swath width when finishing a field with a less-than-full pass.



BOUNDARY SPREADING

Flip a switch and the NL5000 G5 applies materials along a boundary line, placing nutrients right where crops need them.



CONVEYOR SPEED CONTROL

Advanced hydraulics on the NL5000 G5 support precise conveyor control during deflection control functions, reducing the amount applied.

THE **EASIEST** SPREADER INTERFACE ON THE MARKET

The New Leader User Interface is all about simplicity.

Simplicity for our OEM partners, simplicity for our dealers, and simplicity for our customers.

The New Leader spreaders run completely off software that is truly plug-and-play with an ISOBUS-ready display.

The New Leader User Interface allows you to add improvements and updates that are fully-tested, and provide the best solution to meet your customers' needs while also providing complete support.

Automated service notifications, system monitoring, diagnostic feedback, and other features provide you with critical information you need to make adjustments so you don't experience downtime.

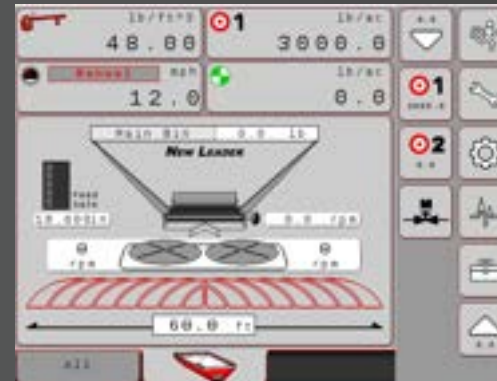

The easy-to-use interface is **simple, yet powerful**. The New Leader technology allows you to quickly and make adjustments on the go for precise and convenient application.



The **Feed Gate Optimizer** tool allows you to enter your average speed, target rate, and product density to get a recommended feedgate height.



Equipped with hardware to meet ISOBUS requirements, use any **ISOBUS-ready** display in the cab of your machine for complete machine control and monitoring in one simple, easy-to-use package.



IT'S ALL ABOUT THE SPREAD PATTERN



Spread patterns are affected by a number of factors such as type of material being spread, spinner speed, condition of the spinner fins, driving centers, wind and humidity, and rate of material delivery. This makes it critical to perform a spread pattern test in order to make any necessary adjustments.

Spread pattern testing should be done prior to each spreading season, after any spreader maintenance, and periodically during the spreading season. Be sure you perform a spread pattern test for each product and application rate.

Our Spread Pattern Test Kit includes the collection trays, test tubes, funnel, rope with pre-determined distance markers, and a New Leader storage box.

WORK **SMARTER** NOT HARDER



The New Leader Mobile app was designed for you, the operator. You put in endless hours and effort, it's time you let the technology do the work for you.

While you're in the field, you can make adjustments, calculations, access service videos, and more.

Available for iOS and Android devices. For more information visit newleader.com/product/new-leader-app.



NO TIME FOR DOWNTIME

The difference between success and failure isn't only about the product itself, it's also the service that follows. In this business, it's expensive to have a machine not working when you are. Which is why it pays to choose New Leader spreaders. Backed by the highest quality service team in the industry so you can focus on what matters.

24-hours-a-day, 365-days-a-year support.

Bottom line: we're always here. Our service and parts departments are ready to answer questions, troubleshoot, and assist in any way possible to minimize downtime and keep you going.





Held to a higher standard.

New Leader thoroughly trains our dealer network through a Certified Technician program. This rigorous training and annual certification ensures our dealers are the best of the best.



We'll stand behind that.

New Leader is proud to build the best equipment of crop nutrient applicators, which is why we're willing to stand behind our products with warranty protection. Through our exclusive OEM partnerships, our units are custom designed to work seamlessly with each chassis model to maximize reliability and service life.



NEWLEADER.COM

Products and specifications subject to change without notice.
Photos and illustrations may or may not include optional equipment.
New Leader® is a registered trademark of Highway Equipment Company.
© 2023 New Leader Manufacturing.
REV 03.2023

