



NL5000 G5 Crop Nutrient Applicator

PRECISION APPLICATION

- 16-section swath width control
- ½ width spreading
- Last Pass Control
- Boundary spreading
- Precise independent spinner control and monitoring
- Automatic feedgate and fan frame control

EASE OF USE

- Intuitive New Leader user interface with up to 25 stored product profiles
- System sensors to monitor spreader performance
- Feedgate optimizer with automatic adjustment

EASE OF MAINTENANCE

- Centralized grease banks
- Automatic chain tensioner
- Automatic chain oiling routine and alarms
- 304 stainless steel cross tubes, mounts, and take-up brackets
- Diagnostic feedback

MULTI-PRODUCT CAPABILITIES

- MultiApplier: Two product, variable rate spreading
 - Enhanced feedgate design for higher outputs
 - Stainless steel connections for easy removal
- MultiBin: Three or four product, variable rate spreading
 - Stainless steel connections for easy removal
 - Optional top cover

SWATH WIDTH CONTROL

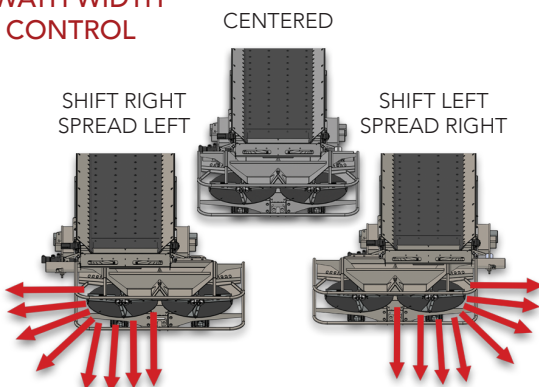



NL5000 G5 Specifications

SINGLE BIN

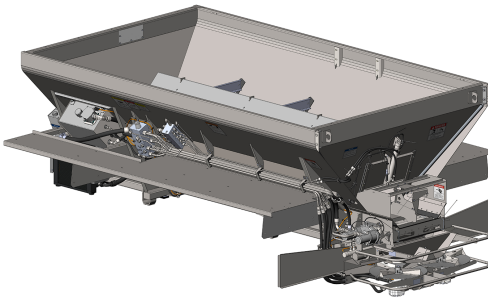

The single bin is available in 304 stainless steel or 409 painted stainless steel. A removable end gate, inverted V, and electric oiler are included.

Unit Length	Estimated Weight	Struck Capacity
13 FT (3.96 M)	1,400 LBS (635 KG)	276 CU FT (7.82 CU M)
14 FT (4.27 M)	1,400 LBS (635 KG)	298 CU FT (8.44 CU M)
16 FT (4.88 M)	1,400 LBS (635 KG)	343 CU FT (9.71 CU M)

MULTAPPLIER™

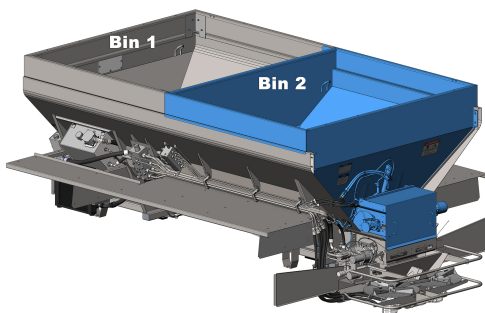

The Multiplier™ allows for two separate materials to be spread simultaneously and features a 24-inch wide #4 belt-over-chain conveyor with 409 stainless steel links. The direct-driven conveyor is also controlled independently enabling the delivery of material at variable rates through the adjustable gate at the rear of the hopper body. The hillside divider improves material placement on the spinner for a more effective spread pattern.

STRUCK CAPACITY FOR 7 FT MULTAPPLIER

	Bin 1	Multiplier Bin	Total
13 FT	166 CU FT (4.70 CU M)	161 CU FT (4.60 CU M)	327 CU FT (9.26 CU M)
14 FT	195 CU FT (5.52 CU M)	161 CU FT (4.60 CU M)	356 CU FT (10.12 CU M)
16 FT	253 CU FT (7.16 CU M)	161 CU FT (4.60 CU M)	414 CU FT (11.72 CU M)

MULTIBIN™

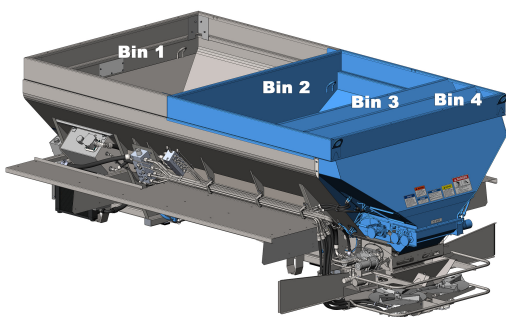

Inserting the MultiBin will convert the spreader to 3 or 4 bins, which can be used independently or together for straight and variable rate applications. Sensors are located in all bins to warn when materials are low. The MultiBin also comes equipped with an upper and lower material divider which improves material placement on the spinner for a more effective spread pattern.

STRUCK CAPACITY

	Bin 1	Bin 2	MicroBin 3	MicroBin 4	Total
13 FT	166 CU FT (4.70 CU M)	139 CU FT (3.94 CU M)	23 CU FT (0.65 CU M)	21 CU FT (0.59 CU M)	349 CU FT (9.88 CU M)
14 FT	195 CU FT (5.52 CU M)	139 CU FT (3.94 CU M)	23 CU FT (0.65 CU M)	21 CU FT (0.59 CU M)	378 CU FT (10.70 CU M)
16 FT	253 CU FT (7.16 CU M)	139 CU FT (3.94 CU M)	23 CU FT (0.65 CU M)	21 CU FT (0.59 CU M)	436 CU FT (12.34 CU M)

Products and specifications subject to change without notice. Photos and illustrations may or may not include optional equipment.