



NL4500 G4



 1330 76th Ave SW
Cedar Rapids, Iowa

 319.363.8281

 NewLeader.com

NL4500 G4

The NL4500 G4 Edge comes standard with independent spinner speed and edge of field technology. With dual RPM sensors, operators can maintain precise speed on each spinner within 5 RPM. Flip a switch, and operators can apply nutrients along a boundary line, leading to improved nutrient placement and decreased nutrient waste.

WHAT IT DOES

Precision Application

- 16-section swath width control
- 1/2 width spreading
- Last Pass control
- Boundary spreading
- Precise independent spinner control and monitoring
- Automatic feedgate and fan frame control

Ease of Use

- Intuitive New Leader user interface with up to 25 stored product profiles
- System sensors to monitor spreader performance
- Feedgate optimizer with automatic adjustments

Ease of Maintenance

- Centralized grease banks
- Automatic chain tensioner
- Automatic chain oiling function and alarms
- 304 stainless steel cross tubes, mounts and take-up brackets
- Diagnostic feedback

Multi-Product Capabilities

- MultiApplier: Two product, variable rate spreading
- MultiBin: Four product, variable rate spreading

TECHNICAL DATA SHEET

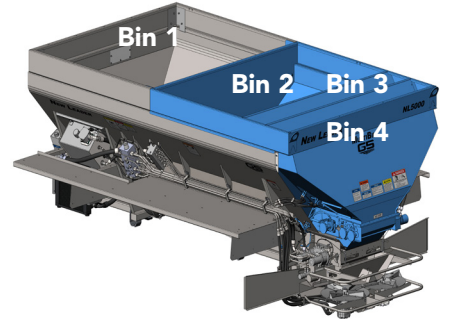
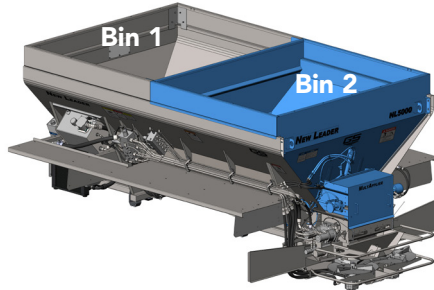
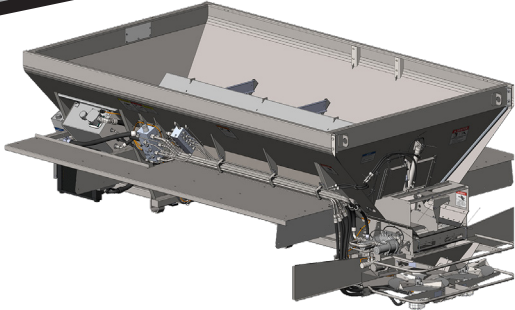

NL5000G4 EDGE

Length	In (Cm)
12' (3.66m)	172 (437)
13' (3.96m)	208 (528)
14' (4.27m)	196 (498)
15' (4.57m)	208 (528)
16' (4.88m)	220 (559)
Length	Cu Ft (Cu M)
12' (3.66m)	253 (7.16)
13' (3.96m)	276 (7.82)
14' (4.27m)	298 (8.44)
15' (4.57m)	321 (9.09)
16' (4.88m)	343 (9.71)
Length	Lbs (kg)
12' (3.66m)	4,400 (1996)
13' (3.96m)	4,600 (2087)
14' (4.27m)	4,800 (2177)
15' (4.57m)	5,000 (2268)
16' (4.88m)	5,400 (2449)

14' MultiBin

Struck Capacity	Cu Ft (Cu M)
Bin 1	195 (5.52)
Bin 2	143 (4.05)
Single Micro - Bin 3	44 (1.24)
Dual Micro - Bin 3	23 (.65)
Dual Micro - Bin 4	21 (.59)
Total Capacity	382 (10.81)
Est. Ship Weight	6,800 lbs (3084 kg)

14' with Sideboards

MultApplier	5 ft MultApplier	7 ft MultApplier
Est. Ship Weight	1,100 (481kg)	1,300 (598kg)
	Capacities with 5 ft MultApplier Cu ft (Cu M)	Capacities with 7 ft MultApplier Cu ft (Cu M)
Insert Capacity	115 (3.25)	161 (4.60)
Struck Capacity	253 (7.16)	195 (5.52)
Total Struck Capacity	368 (10.41)	356 (10.12)