



NL345



 1330 76th Ave SW
Cedar Rapids, Iowa

 319.363.8281

 NewLeader.com

NL345 G4 Edge

The NL345 pull behind broadcast spreader, with its high output and high capacity capabilities, is the ideal spreader for applicators demanding consistent, accurate, and reliable performance for spreading ag lime and dry fertilizer.

The advanced Edge features include precise boundary spreading, automatic chain tensioning, New Leader user interface and much more.

WHAT IT DOES

Precision Application

- Boundary spreading
- Precise independent spinner control and monitoring
- Automatic feedgate and fan frame control
- Optional scales for static and infield calibration
- Optional MultiApplier to spread two products at once

Ease of Use

- Intuitive New Leader user interface
- System sensors to monitor spreader performance
- Feedgate optimizer to calculate height

Ease of Maintenance

- Centralized grease banks
- Automatic hydraulic chain tensioning system
- Automatic chain oiling routine and alarms
- 304-stainless steel feedgate, spinner jacks and handles

Trailer Features

- Heavy-duty trailer main frame with universal hitch
- 4-wheel hydraulic braking system
- Walking suspension with 12" of travel
- High flotation tires for light footprint

TECHNICAL DATA SHEET

Single Bin

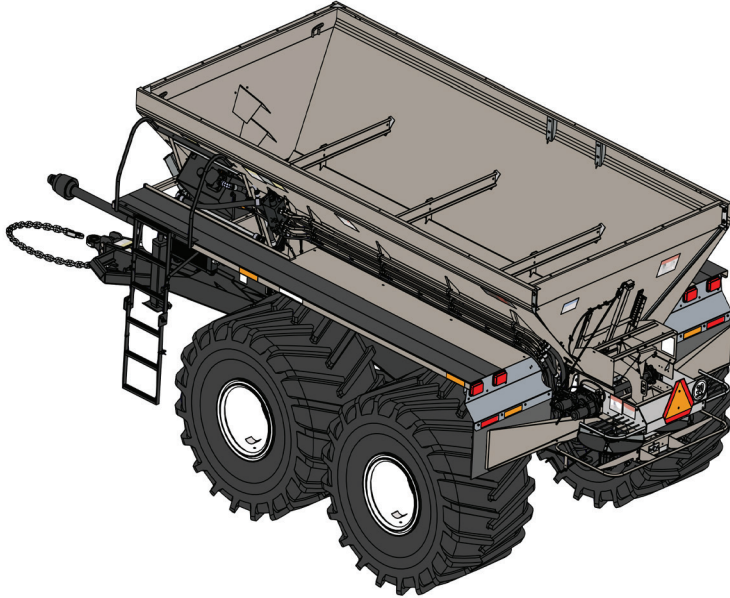

NL34	
Length	In (Cm)
16' (4.88m)	192 (723.9)
Struck Capacity	Cu Ft (Cu M)
16' (4.88m)	343 (9.71)
Estimated Weight	Lbs (Kg)
16' (3.66m)	18,200 (8255)

MultApplier

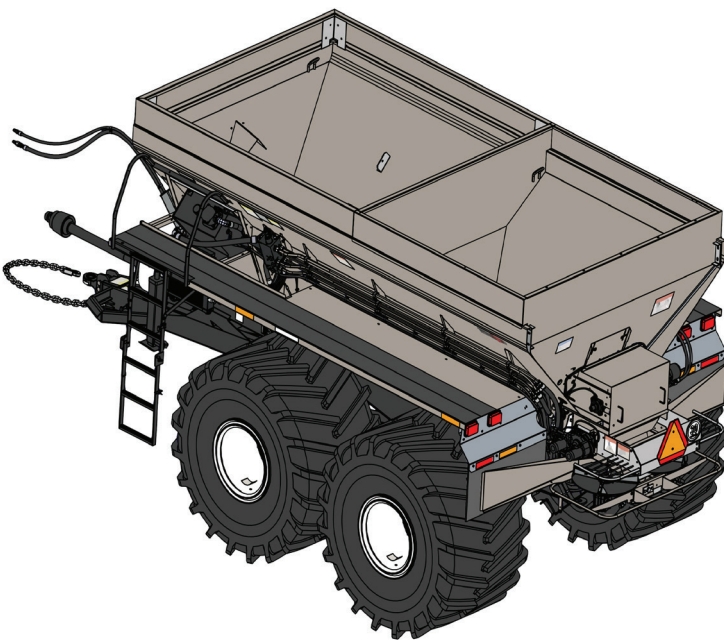

7' MultApplier	
Struck Capacity	Cu Ft (Cu M)
Bin 1	253 (7.16)
Bin 2	161 (4.56)
Total Capacity	414 (11.72)
Est. Ship Weight	19,200 (8709kg)

Features:

- Struck Capacity of 343 ft³ for single bin configuration
- High flotation tires leave light footprint despite massive payload
- 16' - 102 +6 wide body, available in 304 stainless steel or painted 409 stainless steel
- Trailer mainframe with universal bull pull hitch, and four wheel braking system
- Walking suspension that provides over 12" of travel