

NL5000 G5



1330 76th Ave SW
Cedar Rapids, Iowa

319.363.8281

NewLeader.com



NL5000 G5

The NL5000 G5 variable rate dry nutrient applicator can help you meet the demands of prescription nutrient programs. By using G5 spinner technology and leveraging the conveyor speed adjustments, operators can reduce overlap, decrease nutrient waste, and ensure nutrients are placed only where they need them.

WHAT IT DOES

Precision Application

- 16-section swath width control
- ½ width spreading
- Last Pass Control
- Boundary spreading
- Precise independent spinner control and monitoring
- Automatic feedgate and fan frame control

Ease of Use

- Intuitive New Leader user interface with up to 25 stored product profiles
- System sensors to monitor spreader performance
- Feedgate optimizer with automatic adjustment

Ease of Maintenance

- Centralized grease banks
- Automatic chain tensioner
- Automatic chain oiling routine and alarms
- 304 stainless steel cross tubes, mounts, and take-up brackets
- Diagnostic feedback

Multi-Product Capabilities

- MultiApplier: Two product, variable rate spreading
- MultiBin: Four product, variable rate spreading

TECHNICAL DATA SHEET

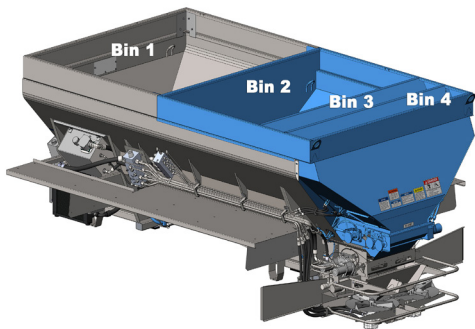
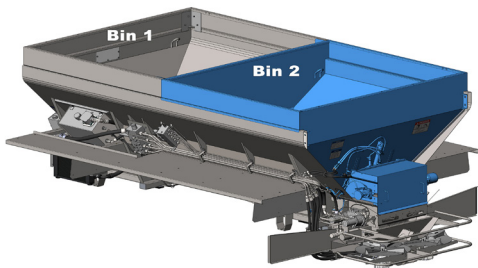
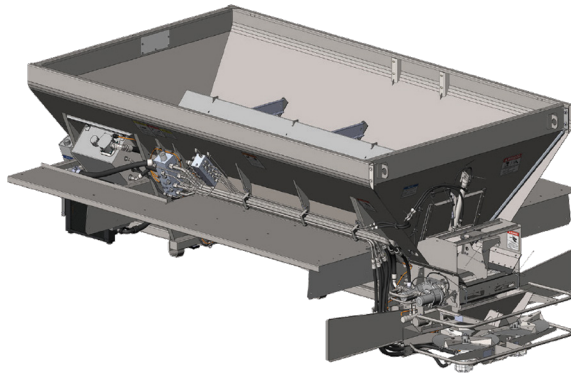

NL5000 G5	
Length	In (cm)
14' (4.27m)	168 (426)
Struck Capacity	Cu Ft (Cu M)
14' (4.27m)	298 (8.44)
Est. Weight	Lbs (kg)
14' (4.27m)	5,100 (2,313)

MultiApplier	5ft MultiApplier	7ft MultiApplier
Est. Ship Weight	1,200 (544 kg)	1,400 (589 kg)
	Capacities with 5 ft MultiApplier cu ft (cu m)	Capacities with 7 ft MultiApplier cu ft (cu m)
Insert Capacity	115 (3.25)	161 (4.60)
14' (4.27m) Bin 1 Struck Capacity	253 (7.16)	195 (5.52)
14' (4.27m) Bin Total Struck Capacity	368 (10.42)	356 (10.08)

MultiBin - Sideboard Included	
Struck Capacity	Cu Ft (Cu M)
14' NL5000 w/ MultiBin - Bin 1	195 (5.52)
MultiBin - Bin 2	143 (4.05)
MultiBin - Bin 3	23 (.65)
MultiBin - Bin 4	21 (.59)
Total Capacity	382 (10.81)

MultiBin - Sideboard Included	
14' Unit - Bin 1 Length w/ MultiBin (B)	84 in (213cm)
Est. Ship Weight	1,800 lbs (816kg)



New Leader Manufacturing
 Equipmentsales@newleader.com
 800-363-8281