

# NL4500T



1330 76th Ave SW  
Cedar Rapids, Iowa

319.363.8281

NewLeader.com

## NL4500T G4 Edge

The G4 Edge variable rate dry nutrient applicator utilizes patented G4 spinner technology, proven to spread materials faster, wider, and more consistently.

The advanced Edge features precise boundary spreading, automatic chain tensioning, New Leader user interface, and much more.

## WHAT IT DOES

### Precision Application

- Boundary spreading
- Precise independent spinner control and monitoring
- Automatic feedgate and fan frame control

### Ease of Use

- Intuitive New Leader user interface
- System sensors to monitor spreader performance
- Feedgate optimizer to calculate height
- Standard High Output Kit for high-rate fertilizer applications (lime excluded)

### Ease of Maintenance

- Centralized grease banks
- Automatic hydraulic chain tensioning system
- Automatic chain oiling routine and alarms
- 304 stainless steel feedgate, spinner jacks, and handles

### Multi-Product Capabilities

- MultiApplier: Two product variable rate spreading
- MultiBin: Four product variable rate spreading
- Optional MicroBin top cover

# TECHNICAL DATA SHEET

Single Bin

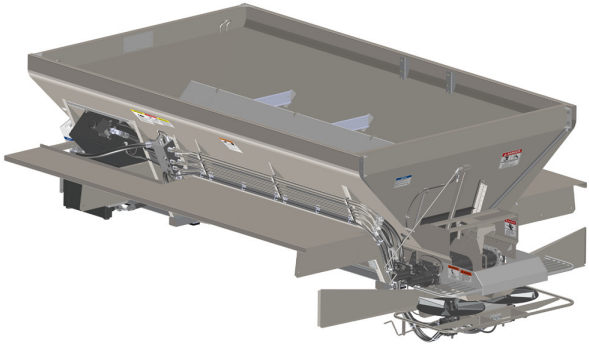

MultApplier

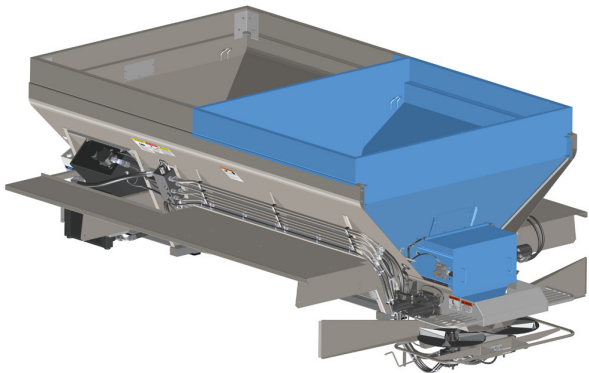

MultiBin

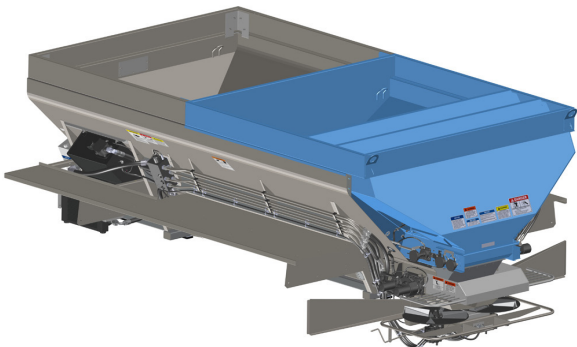

NL4500G4 EDGE	
Length	In (cm)
12' (3.66m)	172 (436.9)
Struck Capacity	Cu Ft (Cu M)
12' (3.66m)	330 (9.34)
Estimated Weight	Lbs (kg)
12' (3.66m)	4,800 (2,177)

MultApplier	5ft MultApplier	7ft MultApplier
Est. Ship Weight	1,000 lbs (498kg)	1,300 lbs (589kg)
	Capacities with 5ft MultApplier Cu Ft (Cu M)	Capacities with 7ft MultApplier Cu Ft (Cu M)
Bin 1 Struck Capacity	190 (5.38)	131 (3.71)
Bin 2 Struck Capacity	115 (3.25)	161 (4.56)
Total Struck Capacity	305 (8.63)	292 (8.27)

12' MultiBin	
Struck Capacity	Cu Ft (Cu M)
Bin 1	131 (3.71)
Bin 2	143 (4.05)
Single Micro - Bin 3	44 (1.24)
Dual Micro - Bin 3	23 (.65)
Dual Micro - Bin 4	21 (.59)
Total Capacity	318 (9.0)
Est. Ship Weight	6,100 (2,767kg)

MultiBin - Sideboard included	
12' Unit Bin 1 Length w/ MultiBin (B)	71 in (180cm)
Estimated Ship Weight	1,700 lbs (771kg)