



NEWLEADER.COM

     
Go ahead, follow us.

New Leader®  
Spinner Spreaders  
AGCO



# ABOUT OUR EXCLUSIVE PARTNERSHIP WITH AGCO

New Leader's partnership with AGCO started in 1960. Our exclusive partnership gives us the ability to customize our spreaders to work seamlessly with designated AGCO chassis models to maximize reliability and service life.



## WHO WE ARE

Building the best since 1939, New Leader Manufacturing is family owned and operated. Our business is built on honesty and integrity. We have a passion for what we do and firmly believe that we can make a better tomorrow by building the best today.

New Leader Manufacturing was founded with a singular focus: to build the best equipment possible. Whether that's spreading salt to deice a highway or nutrients to fertilize a crop, we've focused our business around making sure you have the tools to apply precisely what you need, when you need it.

### Leading Change

As leaders, we never stop moving forward. From designing and building equipment, to helping our customers, continuing to grow a positive and sustainable workplace, and giving back to our community, we believe in leading change.

In 2018 we opened our first international facility, New Leader Indústria e Comércio de Máquinas Agrícolas Ltda. In 2021, we grew into our new manufacturing facility and office location in Indaiatuba, São Paulo, Brazil.

### Spreading Good

Giving back has always been an important value of the company. Through our Spreading Good program, New Leader is dedicated to improving the lives of others. With each NL5000 G5 spreader sold, we help provide clean water to rural African communities.

Supporting people, organizations, and causes that are working to spread good is what it means to be a leader.

We believe in simple things. Like safety, service, and quality. We believe in people. Our people got us here and our people will always be our top priority.



©2021

Owners Matt Rissi and Rocki Shepard

# NL720

Rogator RG934, RG937 & RG937H



## HIGH PRODUCTIVITY

Spread farther than ever before while maintaining your speed. Increase your acres per day, per season, and per year by up to 33%

## LOW-MAINTENANCE DESIGN

There's no time for downtime. With 304 stainless steel construction and no grease points, you can maximize time spent in the field.

## VERSATILITY

Dual bins and stacked conveyors for more application than ever. Spread from 70' to 120' with no additional spread pattern testing or calibration.

Dimensions	12' Model		14' Model	
	Imperial	Metric	Imperial	Metric
Length	12 FT	3.66 M	14 FT	4.27 M
Width	102 IN	259 CM	102 IN	259 CM
Height	67 IN	170 CM	68 IN	172 CM
Weight	6,200 LBS	2,812 KG	6,800 LBS	3,084KG
Struck Capacity	303 CU FT	8.58 CU M	363 CU FT	10.28 CU M



### Productivity

- 120' spread pattern
- 33% more efficient high output design
- Uniformity of spread pattern
- 16-section pattern control
- Boundary and half-width spreading
- 25% increased throughput

### Ease of Use

- Built-in spread pattern wizard for quick start-ups
- Ability to pattern test and set the machine using only 3 pans
- On-screen spread pattern changes from 120' to 90', 80' or 70'
- Conveyor calibration is not required
- Updated easy-to-use in-cab user interface

### Ease of Maintenance

- Zero grease points
- Positive-drive belt design
- Tool-free components
- Easy-to-replace fin overlays
- 304 stainless steel bearings

# NL5000 G5

Rogator RG932, RG934, RG934H, RG937 & RG937H

## UNMATCHED G5 TECHNOLOGY

The NL5000G5 spinner spreader is installed on a RoGator 900 chassis. The G5 variable rate dry nutrient applicator can help you meet the demands of the prescription nutrient programs. By using the G5 spinner technology and leveraging the conveyor speed adjustments, operators can reduce overlap, decrease nutrient waste, and ensure nutrients are placed only where they need them, not where they don't.

## AG LIME COMPATIBLE

Spread Ag Lime using the 253 cu ft, single bin NL5000G5 with the 12-in feedgate height.

## SINGLE BIN

The single bin is available in 409 painted stainless steel. A removable end gate, inverted V, and electric oiler are included.

Dimensions	Without side boards		With side boards	
	Imperial	Metric	Imperial	Metric
Length	12 FT	3.66 M	12 FT	3.66 M
Width	102 IN	259 CM	102 IN	259 CM
Height	59 IN	149.8 CM	69 IN	175.2 CM
Weight	4,200 LBS	1,905 KG	4,500 LBS	2,041 KG
Single Bin Capacity	253 CU FT	7.16 CU M	333 CU FT	9.43 CU M
	12" feedgate for lime & fertilizer capabilities		5" feedgate for fertilizer only capabilities	



Without side boards



With side boards

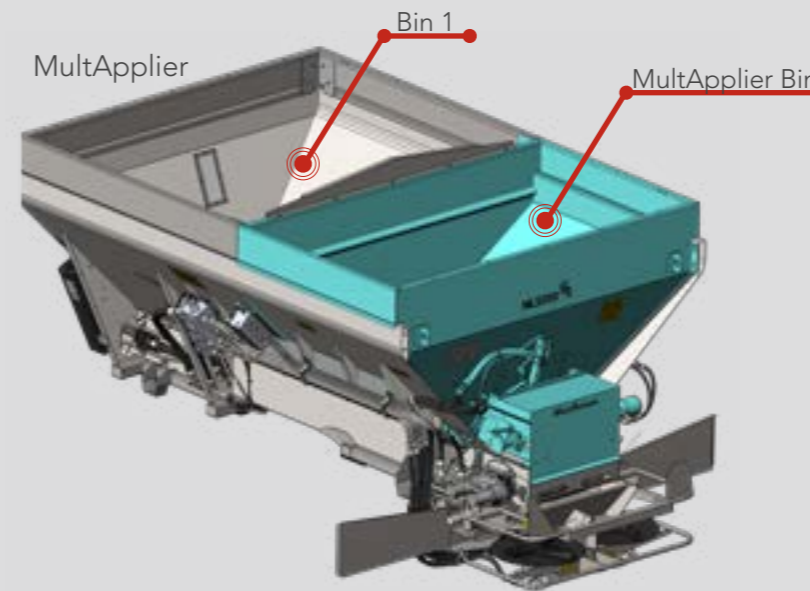

## MULTIAPPLIER™

The MultiApplier allows for two separate materials to be spread simultaneously and features a 24-inch wide #4 belt-over-chain conveyor with 409 stainless steel links. The direct-driven conveyor is also controlled independently enabling the delivery of material at variable rates through the adjustable gate at the rear of the hopper body. The hillside divider improves material placement on the spinner for a more effective spread pattern.

MultiApplier Capacity	Imperial	Metric
Bin 1	195 CU FT	5.52 CU M
MultiApplier Bin	115 CU FT	3.25 CU M
Total Capacity	310 CU FT	8.77 CU M

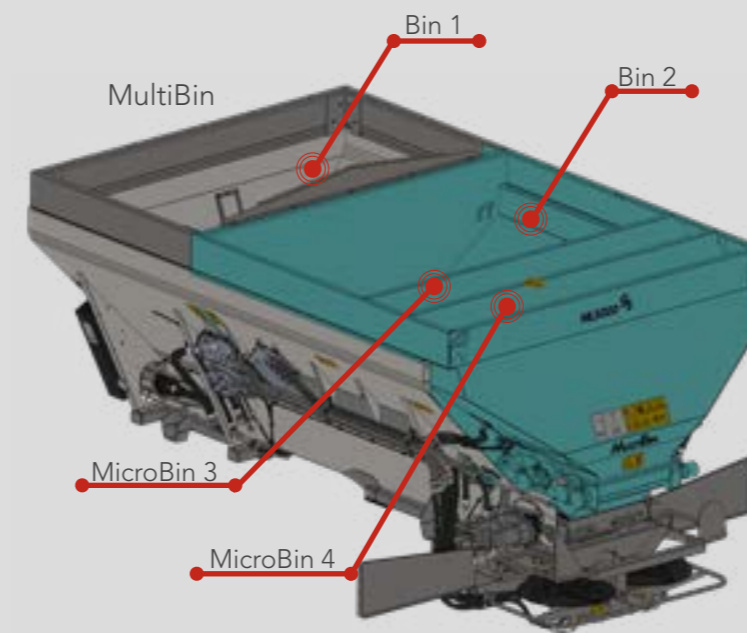

## MULTIBIN™

Inserting the MultiBin will convert the spreader to 4 bins, which can be used independently or together for straight and variable rate applications. Sensors are located in all bins to warn when materials are low. The MultiBin also comes equipped with an upper and lower material divider which improves material placement on the spinner for a more effective spread pattern.

MultiBin Capacity	Imperial	Metric
Bin 1	137 CU FT	3.80 CU M
Bin 2	139 CU FT	3.94 CU M
MicroBin 3	23 CU FT	0.65 CU M
MicroBin 4	21 CU FT	0.59 CU M
Total Capacity	320 CU FT	8.98 CU M

# NL4500G4 Edge

Rogator RG932, RG934, RG934H, RG937 & RG937H

## SPREAD ACCURACY

The NL4500G4 Edge is a 253 cu ft spinner spreader installed on the RoGator 900 series chassis.

## AG LIME COMPATIBLE

The NL4500G4 Edge single bin has the ability to spread Ag Lime, as well as fertilizer.

## SINGLE BIN

The single bin is available in 409 painted stainless steel. A removable end gate, inverted V, and electric oiler are included.

Dimensions	Without side boards		With side boards	
	Imperial	Metric	Imperial	Metric
Length	12 FT	3.66 M	12 FT	3.66 M
Width	102 IN	259 CM	102 IN	259 CM
Height	60 IN	152.4 CM	69 IN	175.2 CM
Weight	3,800 LBS	1,542 KG	4,100 LBS	1,860 KG
Single Bin Capacity	253 CU FT	7.16 CU M	333 CU FT	9.43 CU M
	12" feedgate for lime & fertilizer capabilities		5" feedgate for fertilizer only capabilities	



## MULTAPPLIER™

The MultiApplier allows for two separate materials to be spread simultaneously and features a 24-inch wide #4 belt-over-chain conveyor with 409 stainless steel links. The direct-driven conveyor is also controlled independently enabling the delivery of material at variable rates through the adjustable gate at the rear of the hopper body. The hillside divider improves material placement on the spinner for a more effective spread pattern.

MultiApplier Capacity	Imperial	Metric
Bin 1	195 CU FT	5.52 CU M
MultiApplier Bin	115 CU FT	3.25 CU M
Total Capacity	310 CU FT	8.77 CU M

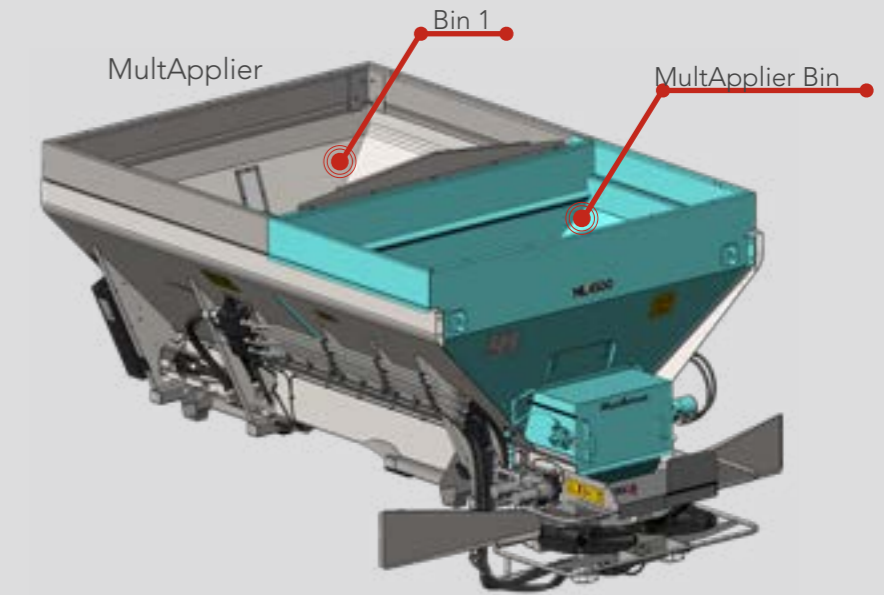

## MULTIBIN™

Inserting the MultiBin will convert the spreader to 4 bins, which can be used independently or together for straight and variable rate applications. Sensors are located in all bins to warn when materials are low. The MultiBin also comes equipped with an upper and lower material divider which improves material placement on the spinner for a more effective spread pattern.

MultiBin Capacity	Imperial	Metric
Bin 1	137 CU FT	3.8 CU M
Bin 2	139 CU FT	3.94 CU M
MicroBin 3	23 CU FT	0.65 CU M
MicroBin 4	21 CU FT	0.59 CU M
Total Capacity	320 CU FT	8.98 CU M

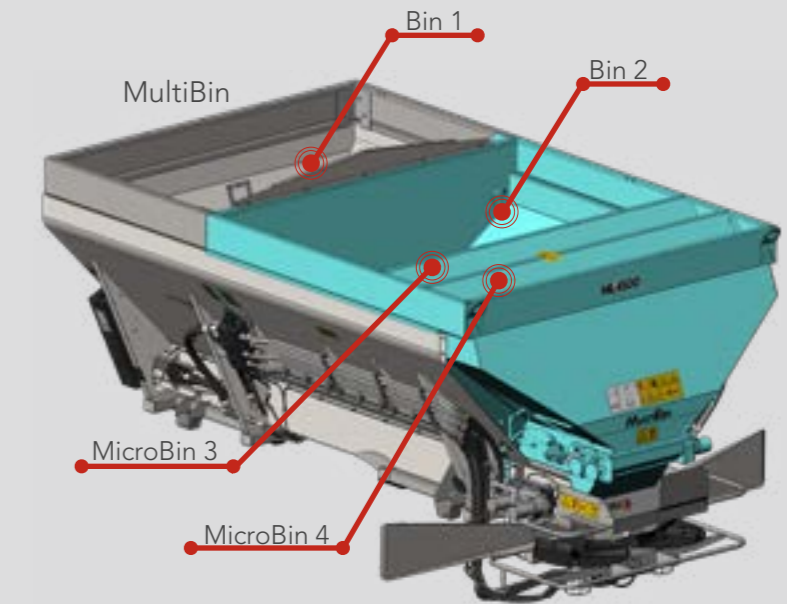

# NL5000 G5

## TerraGator

### UNMATCHED G5 TECHNOLOGY

The NL5000 G5 is a 298 cu ft NL5000 G5 spinner spreader installed on a TerraGator chassis. The G5 variable rate dry nutrient applicator, can help you meet the demands of these prescription nutrient programs. By using the G5 spinner technology and leveraging the conveyor speed adjustments, operators can reduce overlap, decrease nutrient waste, and ensure nutrients are placed only where they need them, not where they don't.

### AG LIME COMPATIBLE

The NL5000 G5 single bin has the ability to spread Ag Lime, as well as fertilizer.

### SINGLE BIN

The single bin is available in 409 painted stainless steel. A removable end gate, inverted V, and electric oiler are included.

Dimensions	Imperial	Metric
Length	14.0 FT	4.27 M
Width	102 IN	259 CM
Height	59 IN	174.7 CM
Weight	5,100 LBS	2,313 KG
Single Bin Capacity	298 CU FT	8.44 CU M



### MULTAPPLIER™

The Multiplier allows for two separate materials to be spread simultaneously and features a 24-inch wide #4 belt-over-chain conveyor with 409 stainless steel links. The direct-driven conveyor is also controlled independently enabling the delivery of material at variable rates through the adjustable gate at the rear of the hopper body. The hillside divider improves material placement on the spinner for a more effective spread pattern.

Multiplier Capacity	Imperial	Metric
Bin 1	195 CU FT	5.52 CU M
Multiplier Bin	161 CU FT	4.60 CU M
Total Capacity	356 CU FT	10.12 CU M

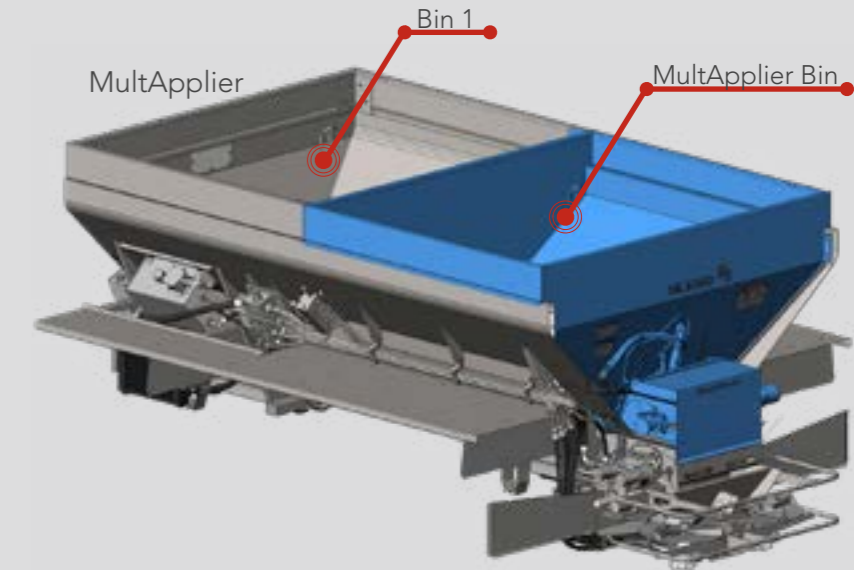

### MULTIBIN™

Inserting the MultiBin will convert the spreader to 4 bins, which can be used independently or together for straight and variable rate applications. Sensors are located in all bins to warn when materials are low. The MultiBin also comes equipped with an upper and lower material divider which improves material placement on the spinner for a more effective spread pattern.

MultiBin Capacity	Imperial	Metric
Bin 1	195 CU FT	5.52 CU M
Bin 2	139 CU FT	3.94 CU M
MicroBin 3	23 CU FT	0.65 CU M
MicroBin 4	21 CU FT	0.59 CU M
Total Capacity	378 CU FT	10.70 CU M

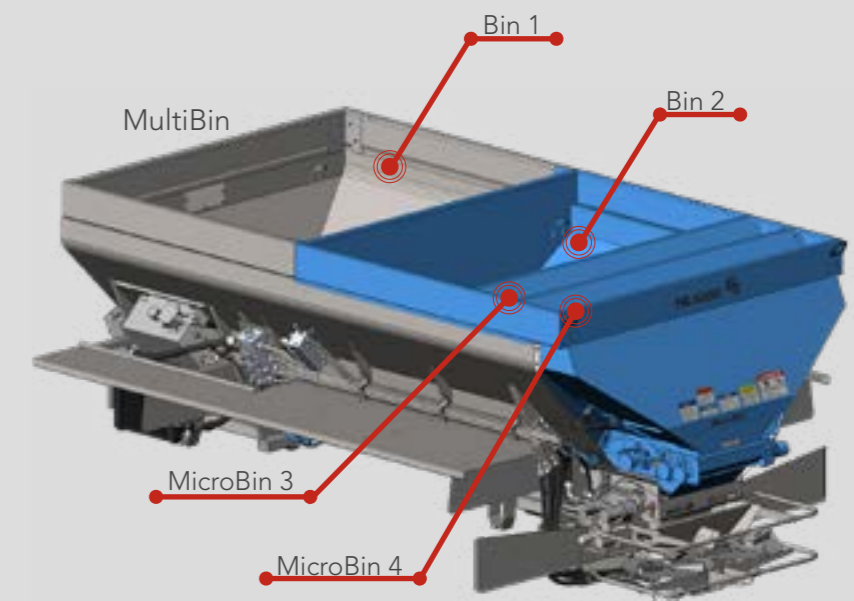



# NL4500G4 Edge

## TerraGator

### SPREAD ACCURACY

The NL4500G4 Edge is a 298 cu ft spinner spreader installed on the TerraGator C series chassis. Available in 14 ft and 15 ft lengths, the NL4500G4 has options and provides performance that pays.

### AG LIME COMPATIBLE

The NL4500 G4 Edge single bin has the ability to spread Ag Lime, as well as fertilizer.

### SINGLE BIN

The single bin is available in 409 painted stainless steel. A removable end gate, inverted V, and electric oiler are included.



Dimensions	14 FT		15 FT	
	Imperial	Metric	Imperial	Metric
Length	14 FT	4.27 M	15 FT	4.57 M
Width	102 IN	259 CM	102 IN	259 CM
Height	60 IN	152.4 CM	60 IN	152.4 CM
Weight	4,800 LBS	2,177 KG	5,000 LBS	2,268 KG
Single Bin Capacity	298 CU FT	8.4 CU M	321 CU FT	9.1 CU M

### MULTAPPLIER™

The MultiApplier allows for two separate materials to be spread simultaneously and features a 24-inch wide #4 belt-over-chain conveyor with 409 stainless steel links. The direct-driven conveyor is also controlled independently enabling the delivery of material at variable rates through the adjustable gate at the rear of the hopper body. The hillside divider improves material placement on the spinner for a more effective spread pattern.

MultiApplier Capacity	Imperial	Metric
Bin 1	195 CU FT	5.52 CU M
MultiApplier Bin	161 CU FT	4.60 CU M
Total Capacity	356 CU FT	10.12 CU M

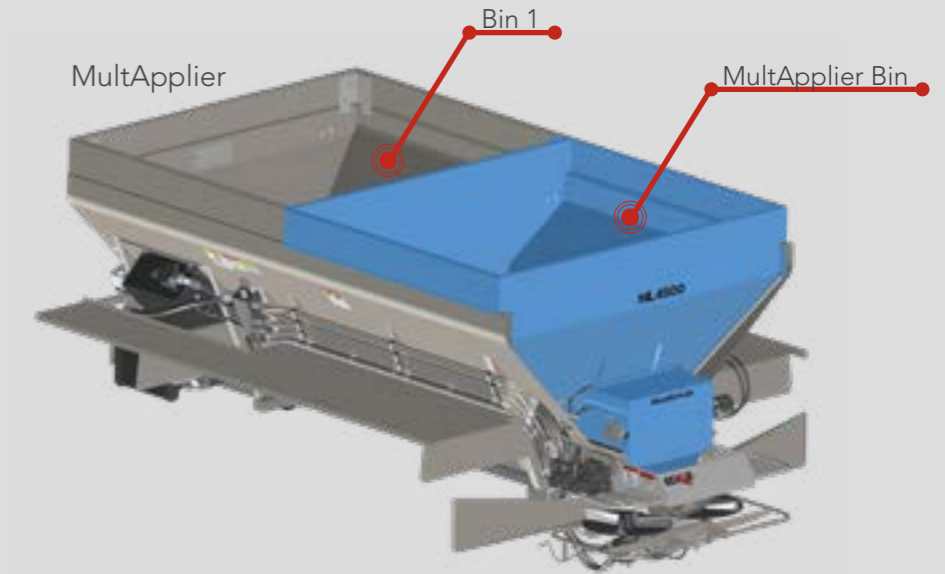

### MULTIBIN™

Inserting the MultiBin will convert the spreader to 4 bins, which can be used independently or together for straight and variable rate applications. Sensors are located in all bins to warn when materials are low. The MultiBin also comes equipped with an upper and lower material divider which improves material placement on the spinner for a more effective spread pattern.

MultiBin Capacity	Imperial	Metric
Bin 1	195 CU FT	5.52 CU M
Bin 2	139 CU FT	3.94 CU M
MicroBin 3	23 CU FT	0.65 CU M
MicroBin 4	21 CU FT	0.59 CU M
Total Capacity	378 CU FT	10.70 CU M

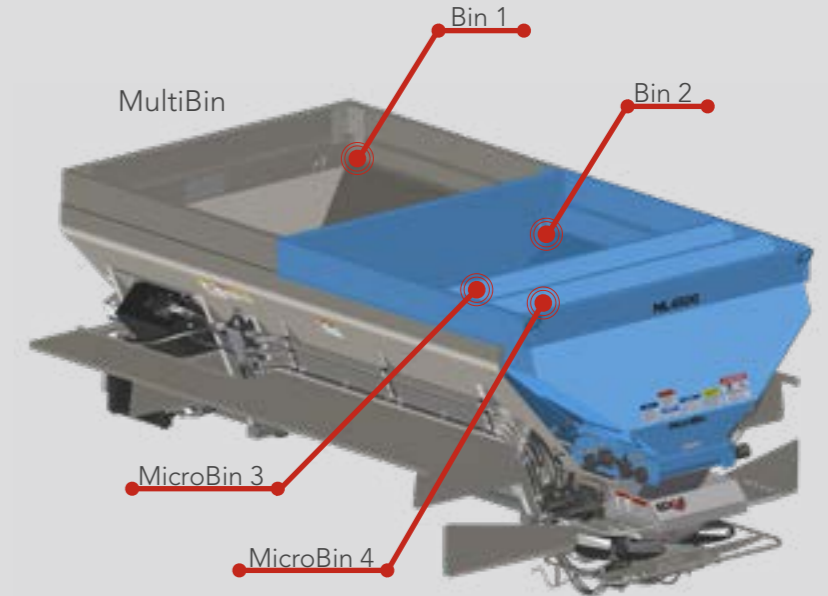

# IT'S ALL ABOUT THE SPREAD PATTERN



Spread patterns are affected by a number of factors such as type of material being spread, spinner speed, condition of the spinner fins, driving centers, wind and humidity, and rate of material delivery. This makes it critical to perform a spread pattern test in order to make any necessary adjustments.

Spread pattern testing should be done prior to each spreading season, after any spreader maintenance, and periodically during the spreading season. Be sure you perform a spread pattern test for each product and application rate.

Our Spread Pattern Test Kit includes the collection trays, test tubes, funnel, rope with pre-determined distance markers, and a New Leader storage box.

# WORK SMARTER NOT HARDER



The New Leader Mobile app was designed for you, the operator. You put in endless hours and effort, it's time you let the technology do the work for you.

While you're in the field, you can make adjustments, calculations, access service videos, and more.

Available for iOS and Android devices. For more information visit [newleader.com/product/new-leader-app](http://newleader.com/product/new-leader-app).

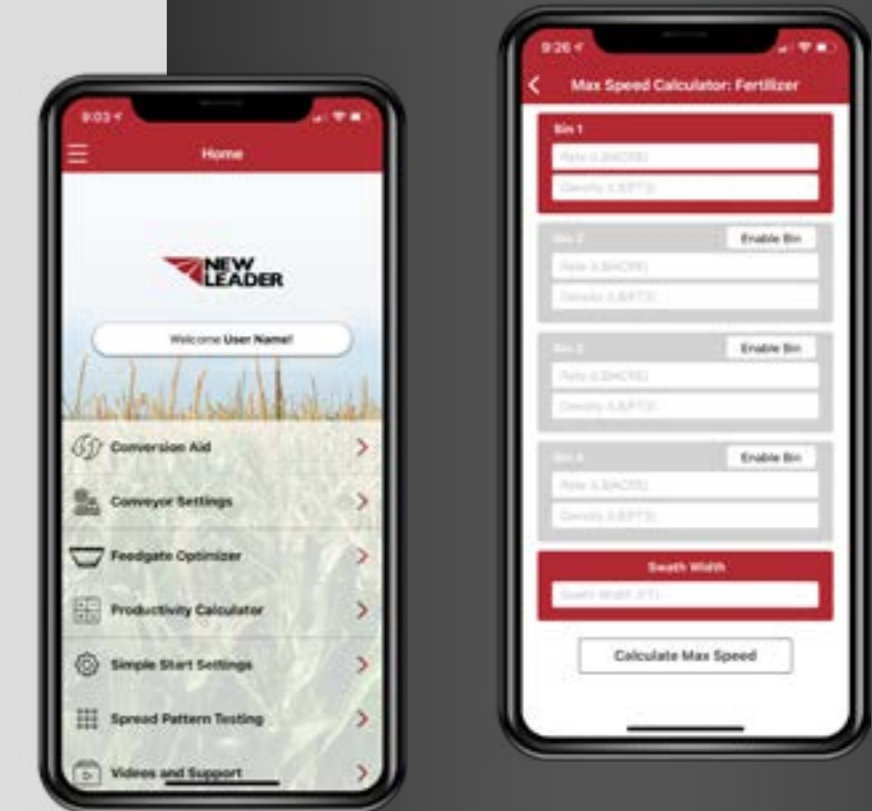

# NO TIME FOR DOWNTIME

The difference between success and failure isn't only about the product itself, it's also the service that follows. In this business, it's expensive to have a machine not working when you are. Which is why it pays to choose New Leader spreaders. Backed by the highest quality service team in the industry so you can focus on what matters.

## **24-hours-a-day, 365-days-a-year support.**

Bottom line: we're always here. Our service and parts departments are ready to answer questions, troubleshoot, and assist in any way possible to minimize downtime and keep you going.



## **Held to a higher standard.**

New Leader thoroughly trains our dealer network through a Certified Technician program. This rigorous training and annual certification ensures our dealers are the best of the best.



## **We'll stand behind that.**

New Leader is proud to build the best equipment of crop nutrient applicators, which is why we're willing to stand behind our products with warranty protection. Through our exclusive OEM partnerships, our units are custom designed to work seamlessly with each chassis model to maximize reliability and service life.



[NEWLEADER.COM](http://NEWLEADER.COM)

Products and specifications subject to change without notice.  
Photos and illustrations may or may not include optional equipment.  
New Leader® is a registered trademark of Highway Equipment Company.  
© 2023 New Leader Manufacturing.  
REV 03.2023

