



1330 76TH Ave SW
Cedar Rapids, IA 52404-7052
Phone: (800) 363-1771
www.NewLeader.com

NL720 RBR

Operator's Manual

Unit Serial No. _____

Manual Number: 322912-B
Effective 09/2024



Serious injury or death can result from the failure to read, understand, and follow instructions provided in this manual. Before using this equipment, read, understand and follow all instructions in this Operator's Manual as well as the chassis operator's manual supplied by your chassis manufacturer.

Serial Plate Location

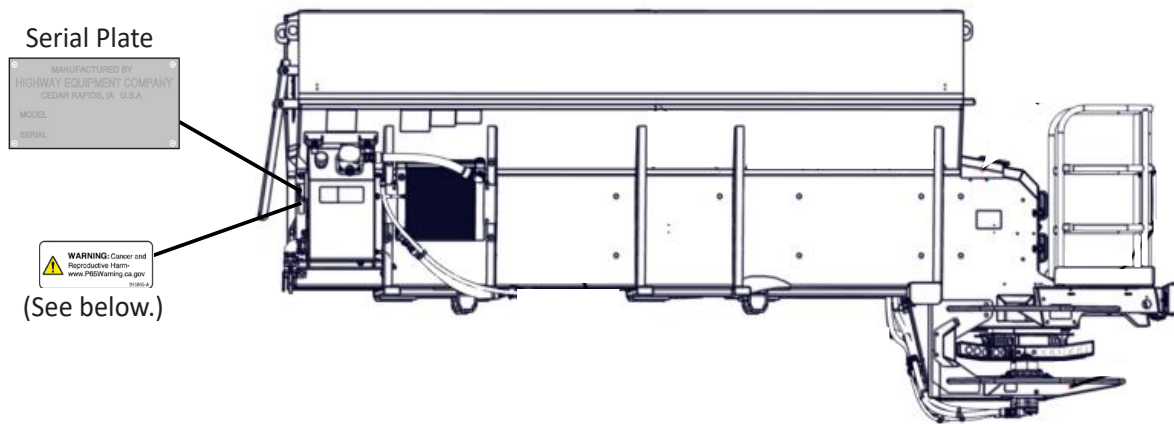

⚠️ WARNING: Operating, servicing, and maintaining NLM spreaders can expose you to chemicals including nickel which are known to the State of California to cause cancer. To minimize exposure, service and maintain your spreader in a well-ventilated area, wear all appropriate protective equipment, and otherwise abide by all safety protocols as outlined in the Operator's manual. For more information, go to www.P65Warnings.ca.gov.

Table of Contents

Serial Plate Location.....	2	General Operating Procedures.....	23
Warranty	4	I. Initial Start-Up.....	23
Introduction and Intended Use	5	II. Calibration	24
Safety First!.....	5	i. Catch Testing	24
Using this Manual	5	ii. Spread-Pattern Testing	25
Operator Support.....	5	Spinners are still running.	27
Protect Your Investment	5	IV. Field Application	31
Ordering Parts	5	i. Start a Job.....	31
Questions? Contact Your Authorized Dealer	5	ii. Activate Boundary Spreading.....	32
Common Terms	6	iv. Create Field Boundary	32
Dimensions and Capacities	6	v. Begin Spreading.....	35
Safety	8	V. Tank Clean Out.....	36
Important Safety Information	8	Lubrication & Maintenance	37
Safety Alert Symbol	8	Preventative Maintenance Pays!	37
Safety Signal Words	8	Hydraulic System.....	37
General Safety Requirements	8	Hydraulic Hoses.....	37
Operations	8	Hydraulic Hose Installation	38
Transportation & Handling	10	Spinner Control Valve	38
Maintenance	11	Conveyor Control Valve	38
Storage	13	Conveyor Belt	39
Safety and Informational Decals.....	14	Electrical Connections	40
Informational Decals.....	14	Clean-Up.....	40
Installation	19	Fin-Overlays	40
Hydraulic Requirements	19	Spinner Deflectors	41
Lifting the Spreader	19	Conveyor Gearcase.....	41
Installing Body	19	Waterfalls.....	41
Mounts	20	Chutes	41
Electrical Connections	20	Chute Bushings	42
Filling Hydraulic System	20	Bin Sensor	42
Hydraulic Hose Installation	20	Hydraulic System Lubrication	42
Hydraulic Hose Installation: General Information	22	Lubricant Specifications.....	42
		Conveyor Gearcase Lubrication Instructions	43
		Standard Torques	43
		Troubleshooting.....	44
		Hydraulic Flow Chart	45

NOTE: The information contained within this manual was current at the time it was published. Some information is subject to change to ensure the best performance of the unit. New Leader Manufacturing reserves the right to make changes in materials or design of the product and its manual at any time without notice.

Check with your Authorized Dealer or call our New Leader Manufacturing (NLM) Product Sales and Support Department at 1-888-363-8006 for the latest version of the manual.

NEW LEADER LIMITED WARRANTY

BASIC WARRANTY

HIGHWAY EQUIPMENT COMPANY d/b/a NEW LEADER MANUFACTURING ("Highway") has manufactured or is distributing the Product/Genuine Parts to which this warranty is attached, and warrants to its original reseller including Dealers, Distributors and Original Equipment Manufacturers (hereafter called Dealer) that the Product/Genuine Parts will, under normal conditions of use and service, be free from material defects due to faulty manufacturing for a period of six (6) months from the date of delivery to the original user. For any Product/Genuine Part that does not conform to the aforesaid warranty within six (6) months from the date of delivery to the original user, your Dealer will, at its option, repair or replace parts. Labor costs for this basic warranty coverage will be paid by Highway to the Dealer at their standard shop rate, based on the amount of time Highway establishes to be the time reasonably necessary to make required repairs. If the Product/Genuine Part is defective in materials or workmanship, you must promptly notify your Dealer; and complete the warranty registration by utilizing the internet at <http://dealer.highwayequipment.com> for such Product before the expiration of the warranty period (Genuine Parts do not require a warranty registration but may require proof of purchase). If your Dealer determines that the defect is due to Highway's material or workmanship, your Dealer will, with Highway's consent, repair such defect during normal working hours, at their location, or such other location as the Dealer may designate. The installation of any part that did not originate from Highway will void this Basic Warranty in its entirety. In the event of repair or replacement, the warranty period shall not be extended beyond the original warranty period. In the case of a demonstration or rental machine (Demo), the warranty will begin at the date of delivery to the original user. If the Demo is sold within the first 120 days of the demo or rental period, the warranty will re-start to the date it is delivered to the end user. If the Demo is sold after the 120th day, the warranty will remain at the date of original delivery to the original user.

NEW LEADER EXTENDED WARRANTY

In lieu of the basic warranty described above, if the warranty registration (or warranty information as provided above) is received at Highway within thirty (30) days after the date of delivery to the original user, Highway will warrant that the Product will, under normal conditions of use and service, be free from material defects due to faulty manufacturing for a period of twenty-four (24) months from the date of delivery to the original user. For any Product that does not conform to the aforesaid warranty within twenty-four (24) months from the date of delivery, your Dealer will, at its option, send you a new part, or give you full credit for the part, provided the replacement part is purchased through your Dealer. Labor costs for this extended warranty coverage will be paid by Highway to the Dealer at their standard shop rate, based on the amount of time Highway establishes to be the time reasonably necessary to make required repairs. If the Product is defective in materials or workmanship, you must promptly notify your Dealer before the expiration of the warranty period. If your Dealer determines that the defect is due to Highway's material or workmanship, your Dealer will, with Highway's consent, repair such defect during normal working hours, at their location, or such other location as your Dealer may designate. In the event of repair or replacement, the warranty period shall not be extended beyond the original warranty period. In the case of a Demo, the warranty will begin at the date of delivery to the original user provided the machine is registered with Highway within 30 days. If the Demo is sold within the first 120 days of the demo or rental period and the machine is registered with Highway within 30 days of the sale, the extended warranty will re-start to the date it is delivered to the end user. If the Demo is sold after the 120th day and is registered with Highway within 30 days of the sale, the extended warranty will remain at the date of original delivery to the original user.

Genuine Parts are covered by the Basic Warranty and are not eligible for the Extended Warranty.

If you fail to complete the warranty registration (or warranty information as provided above) to Highway within thirty (30) days after the date of delivery, the extended warranty shall not apply, and your sole remedy for any defects in the Product shall be under the basic warranty described above. This includes all demo or rental machines.

The above warranties do not cover:

- (1) Product that is damaged by abuse, neglect, accident, or modification;
- (2) fluids, towing, telephone, travel and cleaning cost;
- (3) loss of use of vehicle, inconvenience, commercial loss, or consequential damages;
- (4) any combustion engine; or
- (5) the Product itself if parts are installed on the Product that did not originate from Highway.
- (6) Labor for Genuine Parts

The above warranties do not apply under the following conditions:

- (1) when Product has been improperly used or installed, or modified, or fitted with sideboards, or fails because of defects or inefficiency of components not furnished with the Product;
- (2) **when Product is used for purposes for which it was not originally designed or intended;**
- (3) when Product is used under abnormal operating conditions; or
- (4) when the dealer or user fails to follow Highway instructions regarding the Product, including the instruction to install only Highway supplied parts onto the Product.

HIGHWAY WILL BEAR NO OTHER EXPENSE, INCLUDING BUT NOT LIMITED TO LABOR AND MATERIAL COSTS (OTHER THAN THOSE SPECIFIED HEREIN) OF ANY KIND, AND YOUR EXCLUSIVE REMEDY, IN LIEU OF ALL INCIDENTAL, SPECIAL, CONSEQUENTIAL OR ANY OTHER DAMAGES, INCLUDING, BUT NOT LIMITED TO, DAMAGES FOR NEGLIGENCE, IS LIMITED TO REPAIR OR REPLACEMENT AS HERETOFORE DESCRIBED. THE FOREGOING WARRANTIES ARE IN LIEU OF ALL OTHER REPRESENTATIONS OR WARRANTIES, EXPRESS OR IMPLIED OF ANY KIND REGARDING ANY PRODUCT, INCLUDING BUT NOT LIMITED TO THE IMPLIED WARRANTIES OF MERCHANTABILITY AND FITNESS FOR A PARTICULAR PURPOSE OR USE. IN NO CASE SHALL HIGHWAY BE LIABLE FOR ANY SPECIAL, INCIDENTAL OR CONSEQUENTIAL DAMAGES BASED UPON BREACH OF WARRANTY, BREACH OF CONTRACT, NEGLIGENCE, STRICT TORT, OR ANY OTHER LEGAL THEORY.

Unless modified in writing, signed by both parties, this Limited Warranty is understood to be the complete and exclusive agreement between the parties, superseding all prior agreements, oral or written, and all other communications between the parties relating to the subject matter of this Limited Warranty. No representative or agent of Highway, nor any third party has authority to change or modify this warranty in any respect, nor to assume any other obligation or liability on behalf of Highway. Any action for breach of warranty must be commenced within six (6) months following the expiration of the Limited Warranty.

These warranties are extended only to the original Dealer and are not transferable. In the event of a warranty claim, you should promptly notify your Dealer and provide the following:

1. Model and serial number of the Product;
2. Date of delivery to the original user;
3. Part number of the defective part;
4. Description of the difficulty encountered;
5. Date of repair.

Highway will work with your Dealer regarding instructions for repair, replacement, or refund, if the warranty claim can be validated.

Effective with Product delivered to original user on or after August 25, 2014.

PLEASE! ALWAYS THINK SAFETY FIRST!!

Introduction and Intended Use

The NL720 is a hopper-type fertilizer spreader that is intended for commercial use only. Hydraulically powered, it provides independent variable speed control for the spinner and automatic ground speed control for the conveyor.

The NL720 has four 16" wide (40.6 cm) conveyors that deliver material to the spinners at the rear of the hopper body. The two bottom conveyors extend the full length of the hopper bottom, while the two upper conveyors run half the length of the hopper.

The conveyors are driven by 6-to-1 ratio spur gear cases, each driven by a orbital hydraulic motor. The distributor spinner assembly has two 36" (91 cm) diameter discs.

Safety First!

The Safety section of this manual should be read thoroughly and referred to frequently. The safety instructions indicated by the safety alert symbols supersede the general safety rules.

Using this Manual

The purpose of this manual is to familiarize the Operator with the information necessary to properly install, operate and maintain this system and to create awareness of the hazards that may be encountered because of its use. Proper assembly, maintenance, and safe operating practices will help operators obtain the best results and safe operation from their investment.

Since the life of any machine depends largely upon the care it is given, we require that this manual be read thoroughly and referred to frequently. Keep this manual with the machine for future reference as it is considered part of your machine.

All users must read and understand the information in this manual prior to operation. **Do not allow anyone to operate or maintain this equipment who has not fully read and understood this manual.**

Failure to follow the procedures described in this manual could result in equipment damage or physical injury or death to you or bystanders.

The instructions in this manual cannot replace:

- Fundamental knowledge that the installer or operator must possess
- The ability of a qualified person
- The clear thinking necessary to install and operate this equipment

Operator Support

If, for any reason, you do not understand the instructions, please call your authorized dealer or the New Leader Manufacturing (NLM) Product Sales and Support Department at 1-888-363-8006.

It has been our experience that by following these installation instructions and observing the spreader's operation, you will have a sufficient understanding of the machine, enabling you to troubleshoot and correct all normal problems you may encounter.

Protect Your Investment

Protect your investment by using genuine NLM parts and an authorized dealer for all work other than routine care and adjustments.

New Leader Manufacturing reserves the right to make alterations or modifications to this equipment at any time. The manufacturer shall not be obligated to make such changes to machines already in the field.

Ordering Parts

The parts on your machine have been specifically designed by NLM and should only be replaced with genuine NLM parts. Do not modify the machine or use it with attachments other than NLM options and accessories specified for use with this product.

Contact your dealer if service or repair parts are needed. Your authorized dealer has trained personnel, repair parts, and equipment needed to service this implement.

Record the serial number on page 1 of this manual and again on the warranty page of this manual. You will need these numbers when ordering parts from your dealer. See page 2 for the location of the serial plate on your unit.

Questions? Contact Your Authorized Dealer

Again, we urge you to call your authorized dealer or our Product Sales and Support Department if you find the unit is not operating properly, or if you are having trouble with repairs, installation or removal of this unit.

There may be times when circumstances occur that are not covered in the manual. At those times, or if for any reason you do not understand the instructions or safety requirements in this manual, first contact your dealer. If they are unable to assist, then contact Product Sales and Support Department at 1-888-363-8006.

Common Terms

Following are common terms used in this manual.

- **Bin 1:** The bin closest to the cab.
- **Bin 2:** The bin closest to the spinners.
- **Calibration Chutes*:** Two calibration chutes can be used to bypass the spinner assembly during catch testing.
- **Catch Testing*:** A process that must be completed prior to spread pattern testing to verify the conveyors are dispersing material at the correct rate.
- **Chutes*:** A mobile passage powered by actuators, which accurately delivers material from the waterfalls to the spinners. Two chutes (four total) are installed below each waterfall.
- **Chute Bushings*:** Two bushings per spinner assembly enable chute mobility, which is essential to spreader function.
- **Conveyor:** A belted device that carries material to the rear of the unit.
- **Conveyor Control Valve*:** Controls the hydraulic flow to the conveyor motors.
- **Conveyor Motor:** Turns the conveyor.
- **Cross Tubes:** Attachments on the chassis frame that supports the body by transferring weight from the hopper to the chassis.
- **Endgates:** Front and rear walls of the unit. NL720 endgates are welded in place.
- **Fin-Overlays:** Eight removable fin-overlays (Fig. 53) broadcast material into the field from the unit.
- **Inverted V:** Welded fixtures that reduce start-up pressure on the conveyor and evenly dispense product conveyed out of the bin. This allows for quicker startup and efficient, consistent movement of material; and promotes an improved blend of fertilizer.
- **Lift Hooks:** Used to lift an empty unit with an appropriately rated lifting device.
- **Platform:** Provides access to the waterfalls.
- **Sight Window:** A window to view the inside of Bin 1 from the vehicle cab or the ground.
- **Sill:** Base of Main Hopper side walls. It contains a conveyor and supports machine walls.
- **Spinner Assembly*:** Automatically-adjusted spreader system, consisting of hydraulic spinners that disperse material with a high accuracy rate.
- **Spinner Control Valve*:** This controls the hydraulic flow to the spinner motor.
- **Spinner Deflectors:** Deflects material away from the machine and chassis.
- **Spinner Guards:** Protect the spinner discs and operators—must be installed before any operation.
- **Spinner motor:** A hydraulic motor that turns the spinner discs.

- **Stake:** Side support for machine walls.
- **Waterfall:** Covers the conveyors at the rear of the unit and delivers material from the conveyors to the chutes. Offers tool-free access to inspect passageways and clear buildup and blockages.

*Not pictured on the following page.

Dimensions and Capacities

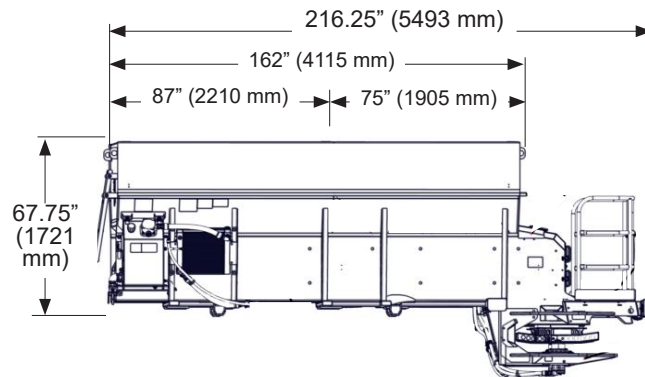
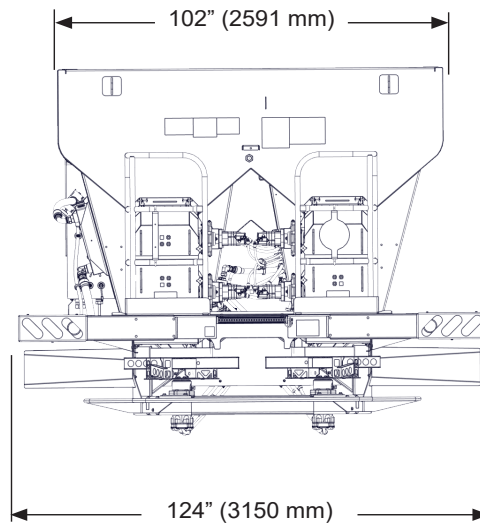

Unit Length Ft (m)	BIN 1 Struck Capacity Cu Ft (Cu M)	BIN 2 Struck Capacity Cu Ft (Cu M)	TOTAL Struck Capacity Cu Ft (Cu M)	Approx. Weight Lbs (Kg)
14' (4.26)	218 (6.2)	145 (4.1)	363 (10.3)	6800 (3084.4)

See previous page for definitions.

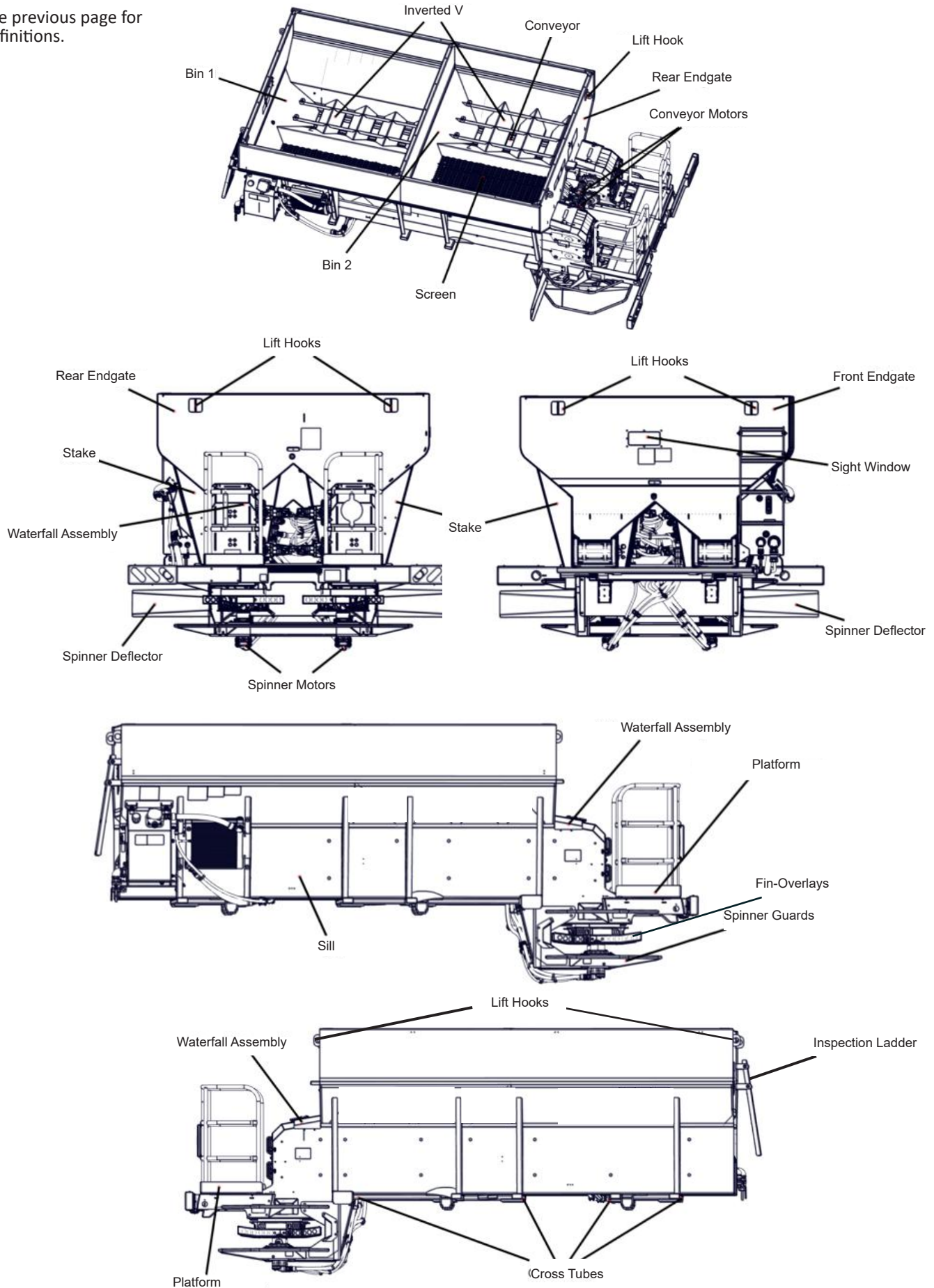

Accidents Hurt!!! Accidents Cost!!! Accidents Can Be Avoided!!!

Safety

Important Safety Information



When operating this equipment, you are responsible for your own safety and the safety of those around you. This machine is designed and equipped with proper safety features, including machine guards and safety labels, to protect you and bystanders from hazards that could cause serious injury.

Guards and safety labels serve a critical purpose and must not be altered. Guards should only be removed for maintenance purposes and must be reinstalled prior to operation. Some of the illustrations in this manual may show the equipment with machine guards removed for clarity. Never operate this machine unless all machine guards are in place.

Safety Alert Symbol



Fig. 1

Fig. 1: This is the safety alert symbol. It is used to alert you to potential physical injury hazards. Obey all safety messages that follow this symbol to avoid possible injury or death.

Safety Signal Words

The safety labels on the machine and safety messages in this manual use a combination of symbols, signal words, and color-coding to identify the following hazardous situations or safety practices:

DANGER	DANGER indicates a hazardous situation which, if not avoided, will result in death or serious injury.
WARNING	WARNING indicates a hazardous situation which, if not avoided, could result in death or serious injury.
CAUTION	CAUTION indicates a hazardous situation which, if not avoided, could result in minor or moderate injury.
NOTICE	NOTICE is used to address practices not related to physical injury.

Additional Definitions

"Important!" indicates a special point of information that the operator should be aware of before continuing.

"Note:" indicates a point of information related to the topic that follows it. This information must be read and understood before continuing.

General Safety Requirements

The following general safety requirements apply to the overall use and maintenance of this machine.

In addition to this safety section, you must also refer to the safety messages and instructions in each of the appropriate sections of this manual. Each section provides further details on section- or task-specific safety messages that alert you about hazards associated with normal use and foreseeable misuse of the machine.

The following guidelines are intended to cover general usage and to assist you in avoiding accidents. There will be times when you will run into situations that are not covered in this section. At those times the best standard to use is common sense. If, at any time, you have a question concerning these guidelines, please call your authorized dealer or our Product Sales & Support Department at (800) 363-1771.

Operations

Prepare for Emergencies

Fig. 2: Be prepared if a fire starts. Keep a fully charged Type ABC or Type BC fire extinguisher and first aid kit in an accessible place on the vehicle at all times. Keep emergency numbers for doctors, ambulance service, hospital and fire department available at all times.



Fig. 2

Inspect Hardware Before Use

Fig. 3: Inspect all bolts, screws, fasteners, keys, chain drives, body mounts and other attachments periodically. Immediately replace any missing or damaged parts with NLM specified parts.

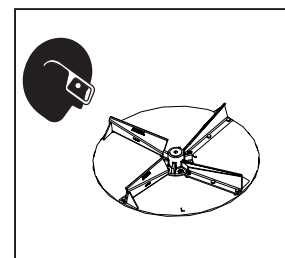

Fig. 3

Inspect spinner fin-overlays, spinner assembly frame mounting and spinner fin-overlay hardware daily.

Look for missing or loose fasteners, wear and cracks. Replace immediately with NLM specified parts.

Tighten all bolts, nuts and screws to specified torques. Refer to "Standard Torques" in the Maintenance section of this manual.

Handle Flammable Materials Safely

Fig. 4: Handle fuel and hydraulic oil with care. They are highly flammable.



Fig. 4

Exposure to toxic fluids or fumes may occur during the normal operation of this system. Before attempting to fill, use, or service this system, read Safety Data Sheets (SDS) to know the specific hazards of the fluids you are using.

Always use proper Personal Protective Equipment when attempting to fill, use, or service this system.

Always stop engine before refueling machine or filling hydraulic reservoir.

Never smoke while adding fuel or oil to machine. Add fluids in a safe place away from open flame and sparks.

Do not allow overflow. Clean up spilled fuel and oil immediately. Always have a multipurpose dry chemical fire extinguisher filled and available during machine operation and when adding fuel. Know how to use it.

Handle Hazardous Materials Safely

Fig. 5: Materials to spread can be dangerous.



Fig. 5

Improper selection, application, use or handling may be a hazard to persons, animals, plants, crops or other property.

A Safety Data Sheet (SDS) provides specific details on chemical products: physical and health hazards, safety procedures and emergency response techniques.

Check all SDSs before starting any job using a hazardous material. Follow all instructions and precautions given by the material manufacturer.

Work in Well-Ventilated Area



Never run machine engine inside a building unless adequate ventilation is provided to safely and properly remove exhaust fumes. Failure to comply with this requirement could result in death or serious injury.

Fig. 6: Always work in a properly ventilated area.

Engine exhaust fumes can cause sickness or death. If it is necessary to run an engine in an enclosed area, use proper equipment to safely remove exhaust fumes from the working area. Open building doors and get fresh air into the working area whenever possible.



Fig. 6

Protect Against Noise

Fig. 7: Long periods of exposure to high decibels or loud noise can cause hearing impairment or loss.

Wear proper hearing protection such as earmuffs or earplugs during periods of exposure to high decibels or loud noise.

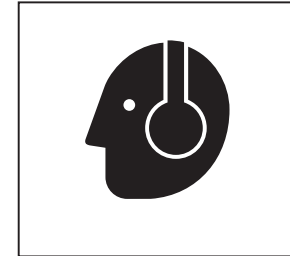

Fig. 7

Avoid Moving Part Hazard

Fig. 8: Entanglement in rotating drive lines or moving parts will cause serious injury or death.

Stay clear of all moving parts, such as shafts, couplings and universal joints.

Make sure all personnel are clear of machine before starting.



Fig. 8

Fig. 9: Do not operate machine without all guards and shields closed and secured.

Disconnect and lock out power source before removing guards.

Disconnect and lock out power source before adjusting or servicing.

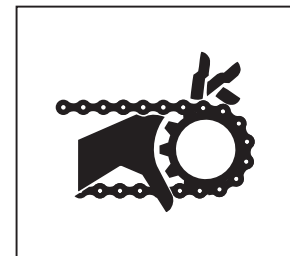

Fig. 9

Keep hands, feet, hair and clothing away from moving parts.

Fig. 10: Keep away from spinners while they are turning.

Rocks, scrap metal and other material can be thrown from the spinners violently. Stay away from discharge area.

Stop machine before servicing or adjusting. Wear eye protection.

Make sure the discharge area is clear before spreading.

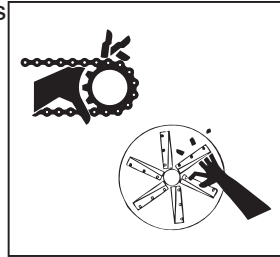

Fig. 10

Fig. 11: Stay out of the spreader.

If necessary to enter the spreader, return to shop, empty body, turn off all power, engage brakes, shut down engine and remove keys before entering.

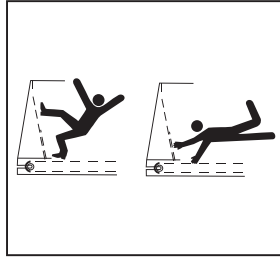

Fig. 11

Tag all controls to prohibit operation. Tags should be placed, and removed, by the person working in the body.

Do Not Climb Or Stand On Machine

Fig. 12: Never allow any personnel to ride in or on the machine.

Use inspection ladder or portable ladder to view the unit. Use caution when getting on and off the ladder, especially in wet, icy, snowy or muddy conditions. Clean mud, snow and ice from steps and footwear.



Fig. 12

Always maintain three points of contact with steps, ladders and handholds. Face the machine when mounting and dismounting inspection ladder. Do not jump off machine.

Operate Machine Safely

Always walk around and visually inspect machine before using. Check the immediate vicinity of machine for people and obstructions. Ensure adequate visibility.

Avoid distractions such as reading, eating or operating personal electronics while operating machine. Never operate the machine under the influence of alcohol, drugs or while otherwise impaired.

Always come to a complete stop before reversing. Be sure that all personnel are clear of machine path. Turn around and look directly for best visibility.

Ensure all rear-view mirrors are properly installed and adjusted. Use a signal person when backing if view is obstructed or when in close quarters.

Always disengage hydraulics before shutting down engine. **DO NOT** start engine with hydraulics engaged.

Transportation & Handling

Traveling & Transporting on Public Roads

Always walk around and visually inspect the machine before traveling on public roads. Check for damage and/or faulty components that can fail and create a hazard or unsafe condition.

Make sure all machine systems operate properly, including but not limited to: headlights, tail and brake lights, hazard warning lights, turn indicators, parking brake, horn and rear-view mirrors. Repair or replace any component that is not in proper working order.

Never drive machine at a speed that causes it to bounce or cause loss of control. Always travel at or below the maximum safe travel speed outlined in the operator's manual of your chassis.

Obey all traffic safety laws and regulations. Operate the machine with hazard warning lights on, unless prohibited by law. It is the operator's responsibility to activate and use road lights properly while traveling on public roads.

Cover all loads that may spill or blow away. Environmental damage may result. Do not spread dusty materials where dust may create pollution, visibility issues or interfere with traffic on public roads.

When transporting equipment or machine on a trailer, ensure it is properly secured. Be sure that SMV signs on equipment or machine are covered while in transport on a trailer.

Be aware of overhead structures and power lines. Make sure machine can safely pass under. Refer to "Dimensions & Capacities" section of this manual.

Navigating Rough & Uneven Terrain

Fig. 13: Turn slowly and be careful when traveling on rough surfaces and side slopes. Avoid holes, ditches and obstructions that may cause machine to roll over, especially with a loaded spreader.



Fig. 13

Never drive near the edge of a gully or steep embankment. Load may shift, causing vehicle to tip.

Maintenance

Read And Understand Maintenance Procedures

Fig. 14: Read the maintenance and safety instructions and understand them before performing any maintenance procedure.

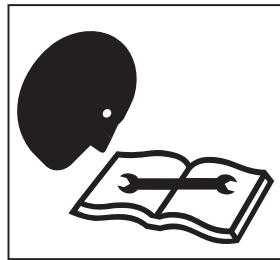

Fig. 14

Never perform any maintenance procedure or repair if the instructions and safety procedures are not fully understood. Only trained and qualified personnel should perform any maintenance procedure or repair.

Never modify any equipment or add attachments not approved by New Leader Manufacturing.

Do Not Service Machine While in Motion

Fig. 15: Never lubricate, service or adjust the machine or any of its components while they are moving.

Never wear loose clothing or jewelry when working near machine tools or moving parts.

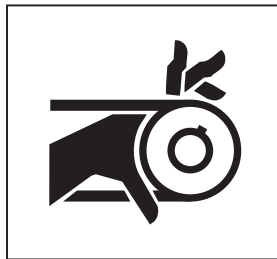

Fig. 15

Remove rings and other jewelry to prevent electrical shorts and other personal injury when in contact with machine tools or moving parts.

Close and secure all guards removed for service. Check all screws, bolts, nuts and fasteners for proper torques before operating machine.

Wear Proper Protective Equipment

Fig. 16: Wear close-fitting clothing and proper safety equipment for the job.

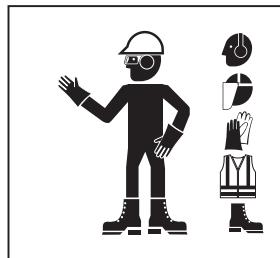

Fig. 16

Always wear eye protection when working on or around the machine.

Wear a suitable hearing protection device such as earmuffs or earplugs to protect against high decibels or loud noises.

Prolonged exposure to high decibels or loud noise can cause hearing impairment or loss of hearing.

Wear protective gloves to protect hands from cuts, abrasions and minor burns.

Handle Flammable Solvents Safely

Fig. 17: Never use diesel fuel, kerosene, gasoline or any flammable solvents for cleaning.



Fig. 17

Exposure to toxic fluids or fumes may occur during the normal operation of this system. Before attempting to fill, use, or service this system, read Safety Data Sheets (SDS) to know the specific hazards of the fluids you are using. Always use proper Personal Protective Equipment when attempting to fill, use, or service this system.

Perform work using flammable fluids and solvents in a safe place away from open flame and sparks. Do not smoke.

Do not weld, grind or flame cut on any tank containing oil, fuel, fumes or any other flammable material, or any container that contents or previous contents are unknown. Move all flammable materials and containers away from work area.

Clean up spilled fuel and oil immediately.

Always have a multipurpose dry chemical fire extinguisher filled and available. Know how to use it.

Use Proper Lifting Equipment

Fig. 18: Use only lifting devices that meet or exceed OSHA standard 1910.184 or ASME B30.20-2013.



Fig. 18

Never lift equipment over people.

Never lift a loaded unit. Never lift unit with any loose objects or persons in the body. Loads may shift or fall if improperly supported, causing death, serious injury or machine damage.

Before unfastening heavy parts or assemblies, support with adequate hoist or other device to prevent falling, tipping, swinging or any other movement that may cause injury or damage.

Use Proper Tools for the Job

Fig. 19: Use of improper tools (such as a screwdriver instead of a pry bar, pliers instead of a wrench, a wrench instead of a hammer) can cause serious injuries or machine damage.

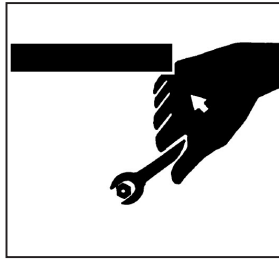

Fig. 19

Use power tools only to loosen threaded parts and fasteners. Using power tools to tighten may cause over-tightening and component damage.

Use only service parts meeting New Leader specifications.

High Pressure Fluid Hazards

Fig. 20: Escaping fluid under pressure can penetrate the skin causing serious injury.



Fig. 20

Always stop machine, allow to cool and relieve pressure before servicing hydraulic system. Never open hydraulic lines under pressure. Make sure all connections are tight and all hoses are in good condition before pressurizing system.

Always use a piece of cardboard or wood to search for leaks instead of hand. Wear impervious gloves and eye protection when servicing system.

Seek medical attention immediately if fluid penetrates your skin. Gangrene may result if wound is left untreated.

Avoid Heating Near High Pressure Fluid Lines

Fig. 21: Flammable spray can be generated by heating near pressurized fluid lines, resulting in burns to yourself and bystanders.

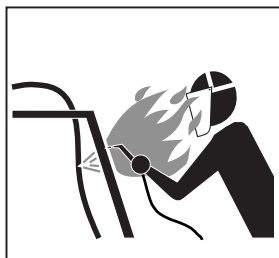

Fig. 21

Do not heat by welding, soldering or using a torch near pressurized fluid lines or other flammable materials.

Pressure lines can suddenly burst when heat goes beyond the immediate flame area.

Avoid Toxic Fumes & Dust

Fig. 22: Hazardous fumes can be generated when paint is heated from welding, soldering or using a torch.



Fig. 22

Remove paint before heating:

- Remove a minimum of 4 in (100 mm) from area to be affected by heating. If paint cannot be removed, wear an approved respirator while heating or welding.
- Avoid breathing dust from sanding or grinding on paint.
- If a solvent or paint stripper is used, wash stripper away with soap and water before heating or welding. Remove solvent or paint stripper containers and other flammable material from area. Allow fumes to disperse for at least 15 minutes before heating or welding.

Do not use chlorinated solvents in areas where welding will take place.

Perform all work in a well-ventilated area that will carry all toxic fumes and dust away.

Clean Machine Of Hazardous Chemical

CAUTION

During application of hazardous chemicals, residue can build up on the inside or outside of the vehicle. Clean vehicle according to use instructions of hazardous chemical. Failure to comply with this requirement may result in minor or moderate injury.

Fig. 23: When exposed to hazardous chemicals, clean exterior and interior of vehicle daily to keep free of the accumulation of visible dirt and contamination.

1. Clean operator's station to maintain unobstructed visibility of all windows and mirrors, and safe operation of all controls.
2. Wash entire exterior of vehicle.
3. Dispose of any wash water with hazardous concentrations of active or non-active ingredients according to published regulations or directives.

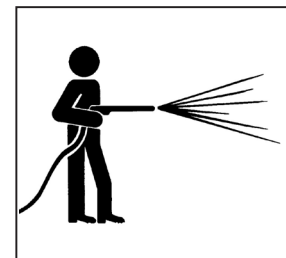

Fig. 23

NOTICE

Directing pressurized water at electronic/ electrical components, bearings and hydraulic seals or other sensitive parts and components may cause product malfunctions. Reduce pressure and spray at 45 to 90 degree angles.

Handle Batteries Safely

WARNING Sulfuric acid in battery electrolyte is poisonous. It can burn skin, eat holes in clothing, and cause blindness if it contacts eyes. Keep sparks and flame away from batteries. Wear proper safety equipment. Failure to comply with this requirement could result in death or serious injury.

Fig. 24: Lead acid batteries generate flammable and explosive gases. Keep sparks and flame away from batteries. Do not smoke.

If acid contacts eyes, skin or clothing, flush with water immediately. Seek immediate medical attention if acid contacts eyes.

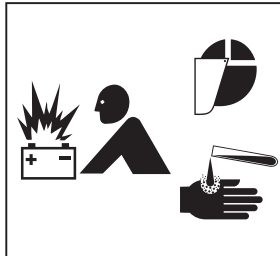

Fig. 24

Proper Tire Maintenance

Fig. 25: Never weld on a wheel or rim that has a tire on it.

Never attempt to mount or remove a tire unless using the proper equipment, tire safety cage, instructions, training, and you are qualified to perform the work safely. Failure to follow the correct procedures when mounting a tire on a wheel or rim can cause an explosion and serious injury.



Fig. 25

Tire service procedures must be performed by trained and qualified personnel.

Storage

Park Vehicle Safely

Fig. 26: When leaving the vehicle unattended for any reason, be sure to:

1. Shut down PTO.
2. Shut off vehicle's engine, and unit's engine if applicable.
3. Place vehicle transmission in "Neutral" or "Park".
4. Set parking brake firmly.
5. Remove ignition key and take it with you.
6. Block wheels.

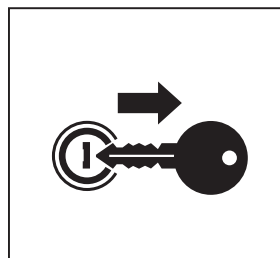

Fig. 26

These actions are recommended to avoid unauthorized use, runaway, vandalism, theft and unexpected operation during startup.

Support Machine Properly

Fig. 27: When machine is removed from vehicle, always store on adequate supports on a firm level surface.

Improper supporting or storage of spreader may cause machine to fall, resulting in serious injury or death.

Never use lifting device to free machine from a chassis, storage stands or frozen ground, or to lift the chassis in any way.

Shock loading is prohibited and sudden accelerations must be avoided.

Lifting in such a manner could result in injury or machine damage.



Fig. 27

Dispose of Waste Properly

Fig. 28: Improper disposal of waste can threaten the environment and ecology.

Potentially harmful waste used with equipment include items such as fuel, oil, filters and batteries.

Use leakproof containers when draining fluids. Do not use food or beverage containers that may mislead someone into drinking from them. Do not pour waste onto the ground, down a drain, or into any water source.

Comply with all OSHA, local, City, State, Province, Country and jurisdiction regulations, ordinances and standards, related to your particular work area and environment.

Inquire on proper disposal methods from your local environmental or recycling center, or from your local dealer.

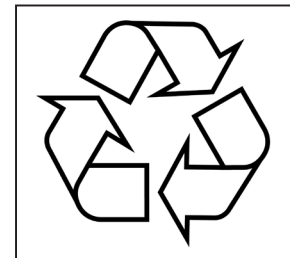

Fig. 28

Safety and Informational Decals

Your spreader comes equipped with all safety and informational decals in place. These safety decals are designed to help you safely operate your equipment. They inform you about possible hazards associated with the normal operation or foreseeable misuse of the product and how to properly avoid those hazards to prevent physical injury or death. You are required to read and follow their directions.

Care and Installation

Keep all safety decals clean and legible.

Replace all damaged or missing decals.

New equipment installed during repairs may require new replacement safety decals to be affixed to the replaced part (see the instructions below).

Safety decals or signs are available from your dealer's Parts Department or from New Leader Manufacturing by calling (800) 363-1771.

Instructions: Affixing Safety Decals

1. Clean the placement surface with soapy water or surface cleaning solution and allow it to dry.
2. Peel backing from the decal, carefully center, and place the decal in the proper location, ensuring no creases or air pockets.
3. Press the decal firmly onto the surface and use a straight edge to smooth the decal on the machine for secure adhesion.

Informational Decals

Informational decals have a blue header and relay important maintenance and operational information. See "Lubrication & Maintenance" on page 37 to read more about the care and maintenance of your unit.

Safety Decals

This section shows the location of each safety decal on the unit along with a reproduction of the decal.

Decals with two part numbers vary in size due to their location on the unit.

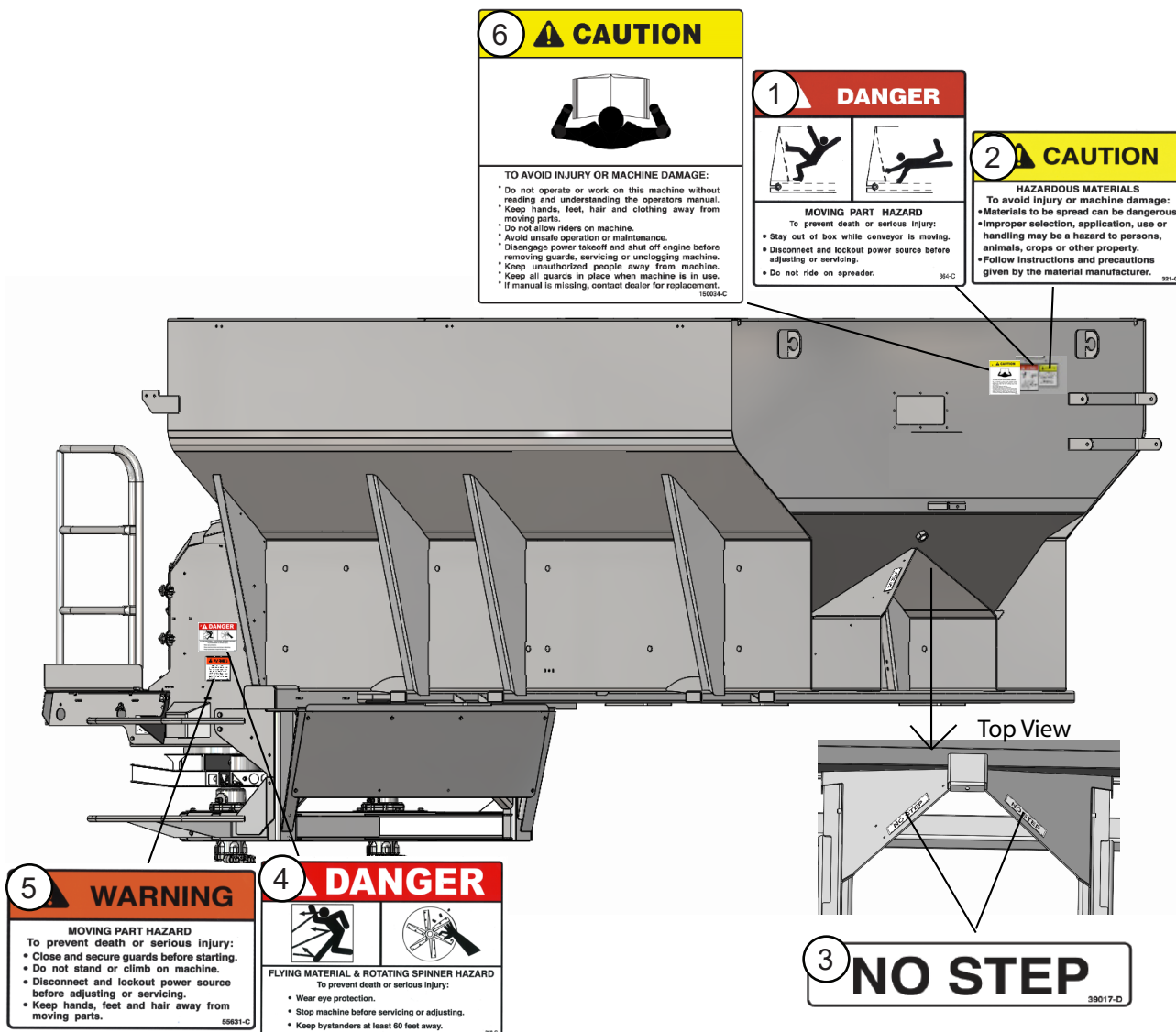

1. Decal #364

DANGER

MOVING PART HAZARD

To prevent death or serious injury:

- Stay out of box while conveyor is moving.
- Disconnect and lockout power source before adjusting or servicing.
- Do not ride on spreader.

364-C

2. Decal #321

CAUTION

HAZARDOUS MATERIALS

To avoid injury or machine damage:

- Materials to be spread can be dangerous.
- Improper selection, application, use or handling may be a hazard to persons, animals, crops or other property.
- Follow instructions and precautions given by the material manufacturer.

321-C

3. Decal #39017

NO STEP

39017-D

4. Decal #368

DANGER

FLYING MATERIAL & ROTATING SPINNER HAZARD

To prevent death or serious injury:

- Wear eye protection.
- Stop machine before servicing or adjusting.
- Keep bystanders at least 60 feet away.

5. Decal #55631

WARNING

MOVING PART HAZARD

To prevent death or serious injury:

- Close and secure guards before starting.
- Do not stand or climb on machine.
- Disconnect and lockout power source before adjusting or servicing.
- Keep hands, feet and hair away from moving parts.

55631-C

6. Decal #150034

CAUTION

TO AVOID INJURY OR MACHINE DAMAGE:

- Do not operate or work on this machine without reading and understanding the operators manual.
- Keep hands, feet, hair and clothing away from moving parts.
- Do not allow riders on machine.
- Avoid unsafe operation or maintenance.
- Disengage power takeoff and shut off engine before removing guards, servicing or unclogging machine.
- Keep unauthorized people away from machine.
- Keep all guards in place when machine is in use.
- If manual is missing, contact dealer for replacement.

150034-C

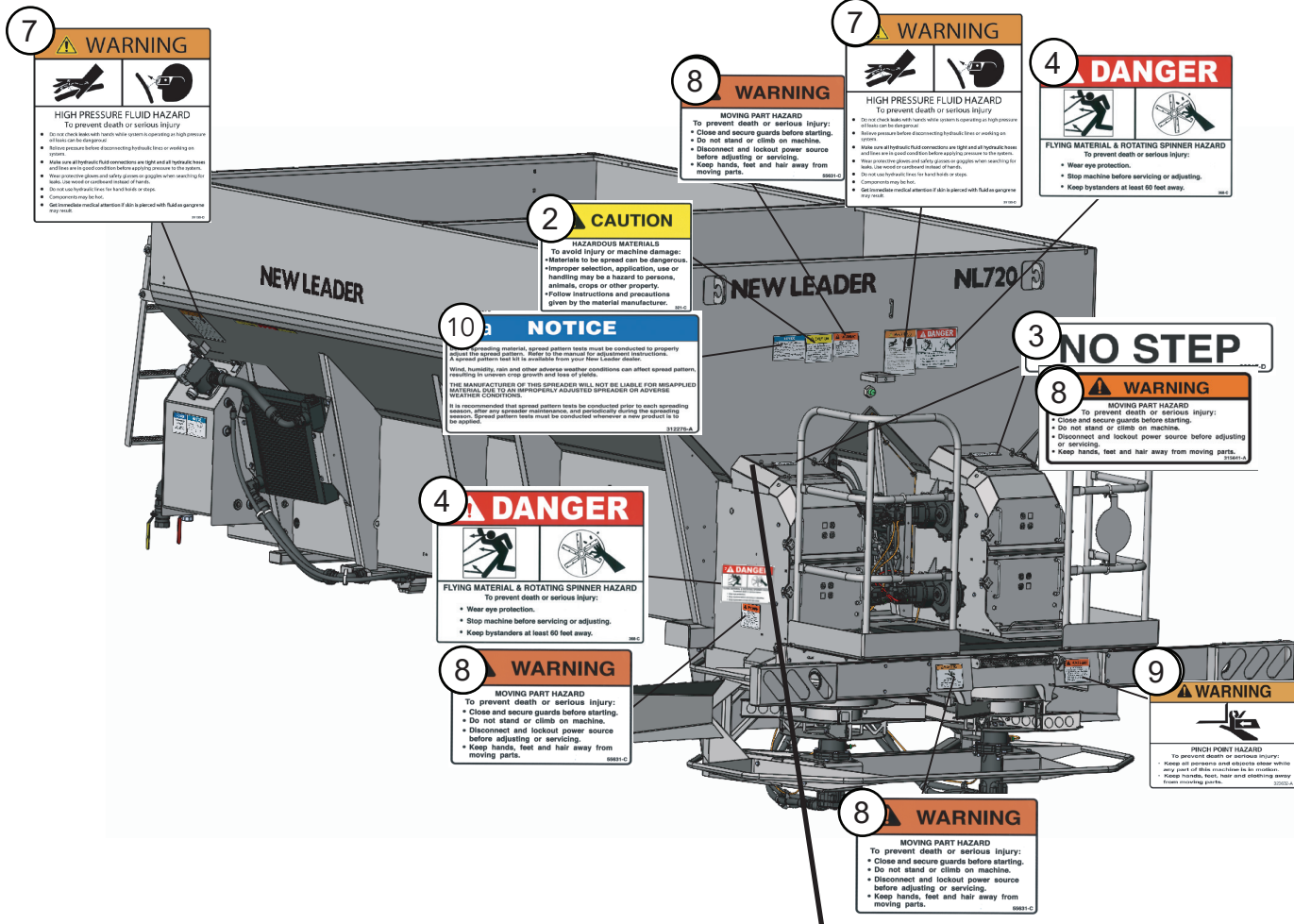

Endgate with waterfall covers removed:



Decal #308191

⚠ DANGER

GUARD IS MISSING WHEN THIS IS VISIBLE

To prevent death or serious injury:

- Do not operate this unit without guard in place.

308191-A

7. Decal #39138

WARNING

HIGH PRESSURE FLUID HAZARD
To prevent death or serious injury

- Do not check leaks with hands while system is operating as high pressure oil leaks can be dangerous!
- Relieve pressure before disconnecting hydraulic lines or working on system.
- Make sure all hydraulic fluid connections are tight and all hydraulic hoses and lines are in good condition before applying pressure to the system.
- Wear protective gloves and safety glasses or goggles when searching for leaks. Use wood or cardboard instead of hands.
- Do not use hydraulic lines for hand holds or steps.
- Components may be hot.
- Get immediate medical attention if skin is pierced with fluid as gangrene may result.

39138-D

8. Decal #315641

WARNING

MOVING PART HAZARD
To prevent death or serious injury:

- Close and secure guards before starting.
- Do not stand or climb on machine.
- Disconnect and lockout power source before adjusting or servicing.
- Keep hands, feet and hair away from moving parts.

315641-A

9. Decal #319300

WARNING

PINCH POINT HAZARD
To prevent death or serious injury:

- Keep all persons and objects clear while any part of this machine is in motion.
- Keep hands, feet, hair and clothing away from moving parts.

323632-A

10. Decal #312276

NOTICE

Before spreading material, spread pattern tests must be conducted to properly adjust the spread pattern. Refer to the manual for adjustment instructions. A spread pattern test kit is available from your New Leader dealer.

All settings must be entered into the controller correctly per the instructions in the operator's manual and related notices.

Wind, humidity, rain and other adverse weather conditions can affect spread pattern, resulting in uneven crop growth and loss of yields.

THE MANUFACTURER OF THIS SPREADER WILL NOT BE LIABLE FOR MISAPPLIED MATERIAL DUE TO AN IMPROPERLY ADJUSTED SPREADER, IMPROPERLY ENTERED PRODUCT SETTINGS OR ADVERSE WEATHER CONDITIONS.

It is recommended that spread pattern tests be conducted prior to each spreading season, after any spreader maintenance, and periodically during the spreading season. Spread pattern tests must be conducted whenever a new product is to be applied.

312276-C

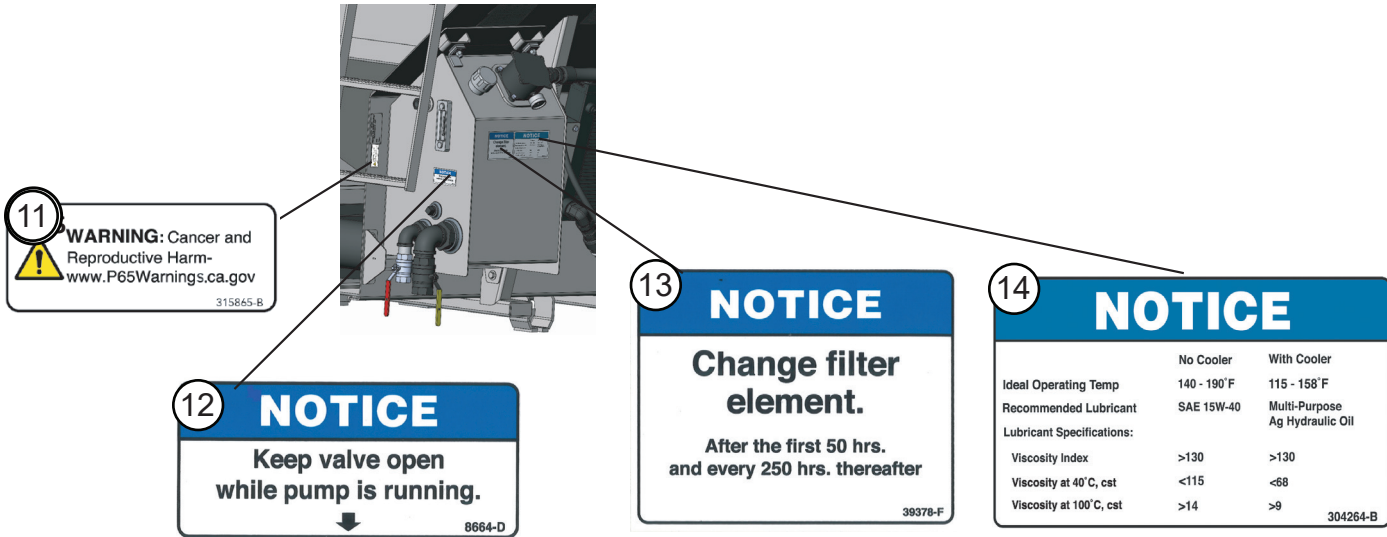

11 **WARNING:** Cancer and Reproductive Harm-
www.P65Warnings.ca.gov
315865-B

12 **NOTICE**
Keep valve open while pump is running.
↓
8664-D

13 **NOTICE**
Change filter element.
After the first 50 hrs. and every 250 hrs. thereafter
39378-F

14 **NOTICE**

	No Cooler	With Cooler
Ideal Operating Temp	140 - 190°F	115 - 158°F
Recommended Lubricant	SAE 15W-40	Multi-Purpose Ag Hydraulic Oil
Lubricant Specifications:		
Viscosity Index	>130	>130
Viscosity at 40°C, cst	<115	<68
Viscosity at 100°C, cst	>14	>9

304264-B

11. Decal #315865



12. Decal #8664 (on the hydraulic tank)



13. Decal #39378 (on the hydraulic tank)



14. Decal #304264 (on the hydraulic tank)

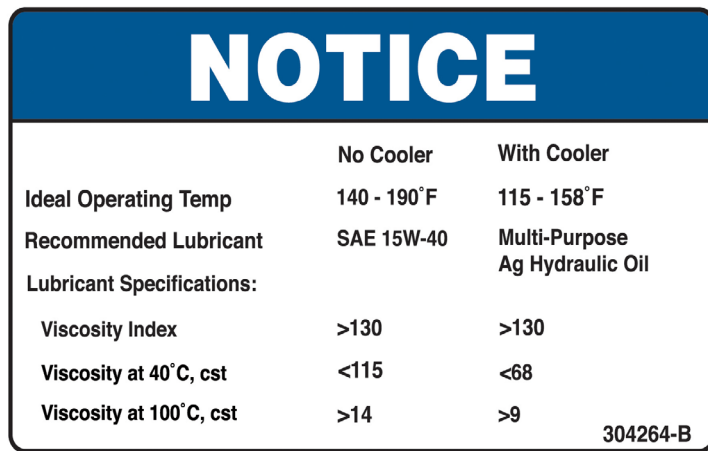

⚠️ WARNING Pump and truck requirements must be determined prior to installation of the spreader.

Installation

The NL720 is installed by the tractor/chassis manufacturer. Refer to your chassis manual and contact your authorized dealer if you desire to remount your unit or move it to a different chassis.

The recommended sequence of installation is:

1. Mount the spreader
2. Install the chassis hydraulic hoses and electrical wiring to spreader.
3. Fill the hydraulic reservoir.
4. Check for leaks and proper function.

This section provides hydraulic requirements, important notices.

Hydraulic Requirements

Hydraulics	Pump Requirement	Max. Pressure (PSI)
Spinner	50 GPM	3100
Conveyor	16 GPM	1200

GPM = Gallons Per Minute

Lifting the Spreader

⚠️ WARNING Use only lifting devices that meet or exceed OSHA standard 1910.184 or ASME B30.20-2006. Never lift equipment over people. Never lift the unit with anything or anybody in the body. Loads may shift or fall if improperly supported. Failure to comply with this requirement could result in death or serious injury.

⚠️ CAUTION Do not use a lifting device to free the unit from a chassis, storage stands or frozen ground, or to lift the chassis in any way. Shock loading is prohibited and sudden accelerations should be avoided. Failure to follow this requirement may result in injury or machine damage.

Operators of lifting devices must be qualified and knowledgeable in their use and application.

Always inspect unit lift points for signs of wear, cracking, corrosion, gouges, alterations, or distortion.

Always use a sling, spreader bar, or lifting bar that attaches to the lifting points with a minimum of 60 degrees from horizontal.

It is preferable to use an H-style lifting bar that keeps the attaching chains in a near-vertical orientation as shown in Fig. 29.

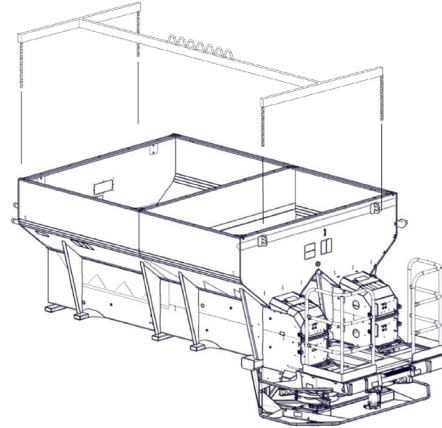

Fig. 29

Position the chassis with adequate room around the unit. Work in an environment that permits clear communication to others nearby. Keep the area clear of people when loads are to be lifted and suspended. Do not allow the lifted load to come in contact with any obstruction.

Store units on a solid surface using appropriate storage stands when not installed.

Installing Body

⚠️ CAUTION Be careful when drilling so as to not damage truck frame, fuel tank, or any other important components.

NOTICE DO NOT WELD ON VEHICLE FRAME! Such welding can lead to fatigue cracking and must be avoided.

NOTICE DO NOT PUT HOLES IN THE TOP OR BOTTOM FLANGES—to do so may void truck manufacturer’s warranty. When drilling holes in frame member, drill only through vertical web portions.

NOTICE Connect welders ground directly to one of the items being welded anytime an arc welder is used on the vehicle or anything connected to the vehicle. Refer to Manufacturer’s instructions.

Mounts

CAUTION

Refer to the chassis operator’s manual for specific procedures on tightening mounting hardware. Failure to follow the procedure per chassis manufacturer may result in injury or machine damage.

Position the unit over the chassis and align the mounts. Carefully lower the unit onto the chassis. Install mounting hardware and tighten to the specified torque. Refer to the chassis operator’s manual for specific hardware tightening procedures.

Electrical Connections

Connect all electrical control circuits. All wiring should be approved automotive insulated wire, supported adequately with insulating ties or straps, and located where it will not interfere with any control or access. Make sure the wiring does not contact any moving parts or sharp edges and is kept away from any hydraulic line or any heated part.

ISOBUS Connections

Fig. 30 shows where the electrical connections are located on your unit.

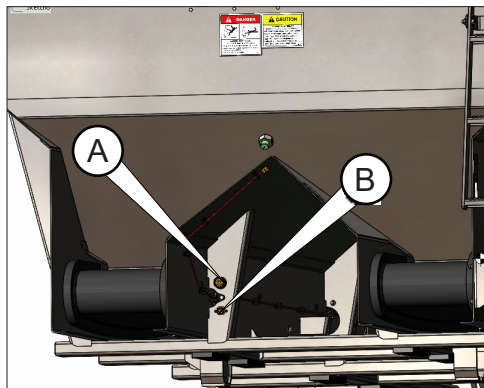

Fig. 30

Fig. 30, Connection A:

- Pin 1: Battery Ground
- Pin 2: ECU Return (ECU Ground)
- Pin 3: 60-amp fused power
- Pin 4: ECU Power (Switched 12v)
- Pin 5: Not Used
- Pin 6: ISO-CAN Return
- Pin 7: ISO-CAN Return
- Pin 8: ISO-CAN High
- Pin 9: ISO-CAN Low

Fig. 30, Connection B:

- Pin 1: Hydraulic cooler fan power (Switched 12V)
- Pin 2: Hydraulic cooler fan ground
- Pin 3: Aux Power
- Pin 4: Aux Ground

Filling Hydraulic System

NOTICE

DO NOT attempt to run the pump without first filling the hydraulic reservoir and opening the suction line valve, or damage to the pump may occur.

Fill the reservoir with hydraulic oil as specified in the “Lubrication and Maintenance” section in the operator’s manual. Be sure the oil is clean and free from dirt, water and other contaminants.

Hydraulic Hose Installation

If you need to route hoses for maintenance or installation, please refer to the manual for your tractor/chassis.

For reference, Fig. 31 and Fig. 32 show the hydraulic hookups. Both valves are installed on the exterior of the unit, in between the conveyors.

Spinner Control Valve

Fig. 31: Connect hydraulic hoses to the appropriate port(s), as shown below:

- A. Return
- B. Pressure Control
- C. Load Sense

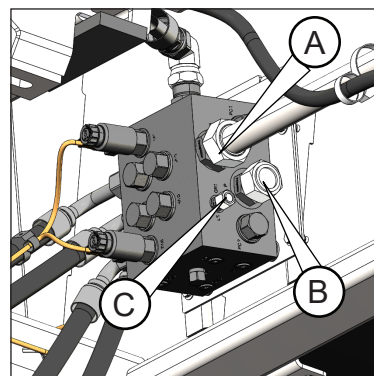

Fig. 31

Conveyor Control Valve

Fig. 32: Connect hydraulic hoses to the appropriate port(s), as shown below:

- A. Return
- B. Pressure Control
- C. Load Sense

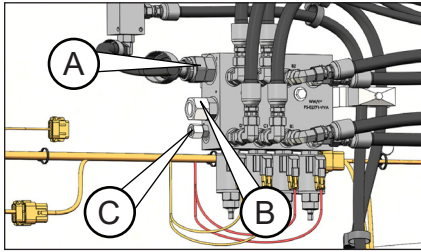
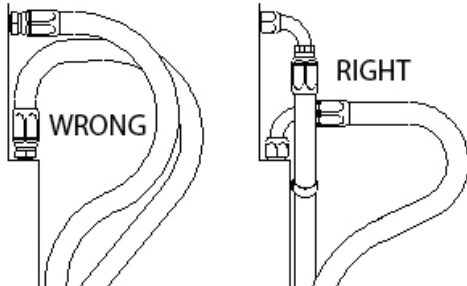
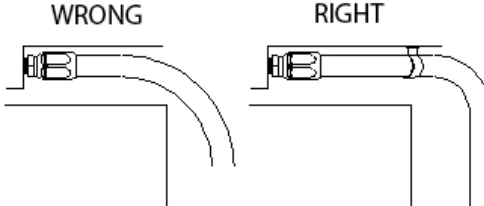
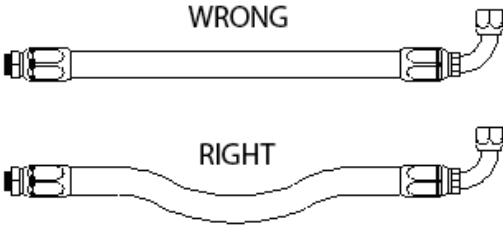
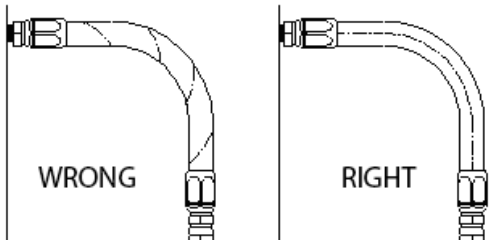
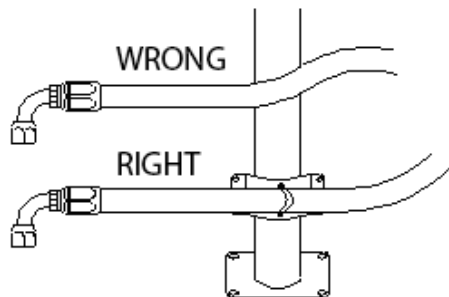
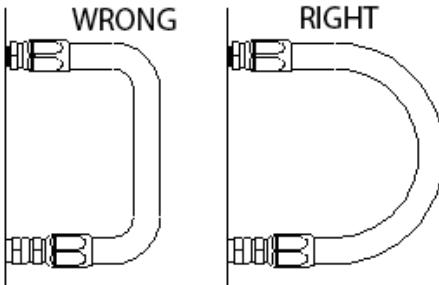

Fig. 32

See the next page for general information to properly route and tension a hydraulic hose. (Instructions are used with the permission of The Weatherhead Company.)

Hydraulic Hose Installation: General Information

	
<p>1. Use elbows and adapters in the installation to relieve strain on the assembly, and to provide easier and neater installations that are accessible for inspection and maintenance. Remember that metal end fittings cannot be considered as part of the flexible portion of the assembly.</p>	<p>2. Install hose runs to avoid rubbing or abrasion. Clamps are often needed to support long runs of hose or to keep hose away from moving parts. It is important that the clamps be of the correct size. A clamp that is too large will allow the hose to move in the clamp causing abrasion at this point.</p>
	
<p>3. In straight hose installations allow enough slack in the hose line to provide for changes in length that will occur when pressure is applied. This change in length can be from +2% to -4%.</p>	<p>4. Do not twist hose during installation. This can be determined by the printed layline on the hose. Pressure applied to a twisted hose can cause hose failure or loosening of the connections.</p>
	
<p>5. Keep hose away from hot parts. High ambient temperature will shorten hose life. If you cannot route it away from the heat source, insulate it.</p>	<p>6. Keep the bend radii of the hose as large as possible to avoid hose collapsing and restriction of flow. Follow catalog specs on minimum bend radii.</p>

General Operating Procedures

- I. **Initial Start-Up.** See the instructions on this page.
- II. **Calibration.** Make sure your spreader is adjusted properly by performing the following. For more information, see [page 24](#).
 - i. **Catch Testing.** Verify material is flowing out of the unit at a proper rate ([page 24](#)).
 - ii. **Spread-Pattern Testing.** Adjust the chutes to give the desired spread pattern. Perform spread pattern testing for any new material. ([page 25](#))
 - 1. Prepare Area and Position Spreader ([page 26](#))
 - 2. Charge Conveyors ([page 27](#))
 - 3. Follow Spread-Pattern Wizard ([page 28](#))
 - 4. Evaluate Spread-Pattern Test Results ([page 30](#))
- V. **Field Application.** Fill bins and begin field application. See [page 31](#).
 - i. **Start a Job**
 - ii. **Activate Boundary Spreading**
 - iii. **Create Field Boundary**
 - iv. **Begin Spreading**
- VI. **Tank Cleanout.** See [page 36](#).

DO NOT check leaks with your hands while the system operates; high-pressure oil leaks can be dangerous! If skin is pierced with hydraulic fluid at high pressure, seek immediate medical attention. Fluid injected into the skin could cause gangrene if left untreated. Relieve pressure before disconnecting hydraulic lines or the working system. Make sure all hydraulic fluid connections are tight, and all hydraulic hoses and lines are in good condition before applying pressure to the system. Wear protective gloves and safety glasses or goggles when working with hydraulic systems. Failure to comply with this requirement could result in death or serious injury.

DO NOT check for leaks adjacent to moving parts while the system is operating, as there may be danger of entanglement! Failure to comply with this requirement could result in death or serious injury.

I. Initial Start-Up

Stand clear of moving machinery. Failure to comply with this requirement could result in death or serious injury.

Take proper safety precautions when observing conveyor and spinner speed while vehicle is in motion! These may include use of suitable mirrors clamped to permit observation by a safely seated observer, following the spreader in another vehicle at a safe distance, or other suitable means. Do not stand on fenders, in body or on any part of spreader as there is danger of falling off the vehicle or into moving parts!

NOTE: Do not load the spreader with material at this time.

1. Check the entire unit to ensure all fasteners are in place and tightened per this manual's "Standard Torques" section.
2. Make sure no one is in the vicinity of the spreader.
3. Make sure loose parts are not in the unit or on the conveyors and/or spinners.
4. Check the oil level in the hydraulic reservoir. See "[Lubrication & Maintenance](#)" on [page 37](#) for more information.
 - A. Fill the hydraulic reservoir as necessary.
 - B. Completely open reservoir valves as necessary.
5. Start the engine and turn on hydraulics—run the hydraulic system to bring oil up to operating temperature.
6. Run the spinners until they operate smoothly and all air has been purged from the system.
7. With potash selected as your product, set the Controller to a 375 lb rate at 15 mph.
 - A. Run the conveyor until it operates smoothly.
 - B. Run conveyor and spinners together until they both operate smoothly.
 - C. Turn off the conveyor and spinner circuit to ensure neither move.
8. Check all connections in the hydraulic system to make sure there are no leaks.
9. Calibrate spreader as defined in this manual for the controller supplied with your machine.
10. Follow "[ii. Spread-Pattern Testing](#)" on [page 25](#).
11. Shut the system down.

II. Calibration

Catch testing and spread pattern testing must be completed prior to operating the NL720 and prior to spreading any new material with the NL720.

i. Catch Testing - Optional

Catch Testing verifies that the unit is spreading the fertilizer from its conveyors at an appropriate rate. This process must be completed before field application.

NOTE: We highly recommend using a calibration chute (Fig. 33) to simplify the catch test process and get accurate results. The optional calibration chute fits all NL720 conveyor bottoms. Contact your local New Leader dealer for details.

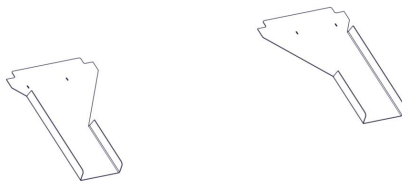

Fig. 33 – Optional Calibration Chutes (Part #323366)

Catch Test Instructions



To prevent injury, disable the spinners by unplugging the PWM valve before beginning the catch test procedure. Failure to comply with this requirement could result in death or serious injury.

1. Disable the spinners by unplugging the coils from the spinner control valves (Fig. 34). Do not unplug the conveyor control valves (Fig. 35).

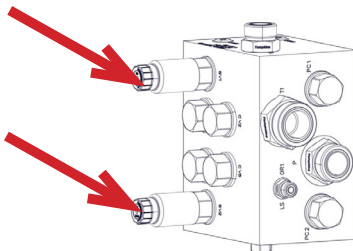

Fig. 34 – Spinner Control

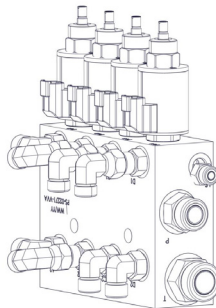

Fig. 35 – Conveyor Control

2. At the rear of the unit, disassemble the waterfall assembly (Fig. 36) using the tool-free pins and knobs. Cutouts (red arrows) illustrate each part's location on the waterfall assembly.
 - A. Remove the waterfall cover using the lock pins.
 - B. Remove the upper and lower waterfall dividers by loosening the knobs and pivoting the bolts out of the way.
 - C. Remove the waterfall baseplates using the knobs.

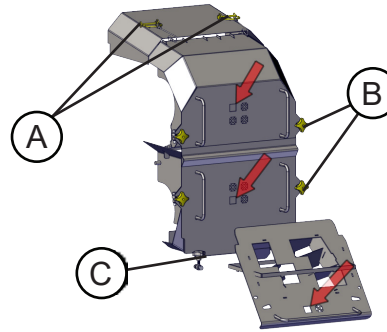

Fig. 36

3. Install the calibration chutes in place of the waterfall baseplates (Fig. 37). Calibration chutes are designed to bypass the spinner assemblies.

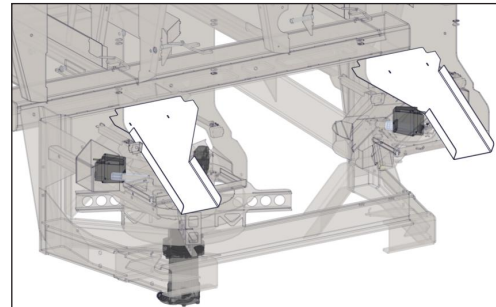

Fig. 37

4. Position an end loader or other suitable catching device beneath the spinners to catch material.
5. Load material into all applicable bins.
6. Start the engine and engage hydraulics.
 - A. Run the engine for several minutes to bring hydraulic oil up to operating temperature.
 - B. Bring the engine up to operating RPM.
7. Charge the conveyor as specified in the controller. For additional information, see "V. Tank Clean Out" on page 36.
 - A. If using a calibration chute, run the conveyor only until the material reaches the end of the conveyor.
 - B. Remove any excess material that falls into the catching device.
8. Follow the Catch Test Calibration instructions displayed on the screen. NLM Recommends a minimum of 800 pounds per catch test. Return to Step 2 on this page for each bin.
9. Once satisfactory results have been achieved for all applicable bins, turn off the engine, replace the parts that were removed in Step 2 on this page (in reverse order).
10. Plug the PWM valve(s) back in.

NOTE: For assistance with the controller operations and setup, contact your local dealer.

ii. Spread-Pattern Testing

NOTICE Chute position adjusts the spread pattern. A spread pattern test kit is available to calibrate the machine. THE MANUFACTURER OF THIS SPREADER WILL NOT BE HELD LIABLE FOR MISAPPLIED MATERIAL DUE TO AN IMPROPERLY ADJUSTED SPREADER.

Spread pattern testing is required to ensure proper fertilizer application.

An Operator must complete spread pattern testing per the instructions in this manual each time a new or different material is spread. Product quality and size may affect the spread pattern and product performance. For example, larger material produces wider swath widths.

Spread Pattern Test Kit

You must use the Spread Pattern Test Kit, which includes the following:

Description	QTY
Plastic Storage Box	1
Blue Plastic Collection Trays	3
White Divider Screens	3
Test Tube Rack Assembly	1
Test Tubes	3
Scale – Density	1
Stakes	2
Funnel	1
Rope	1
Flags	2

Fig. 38: The rope included in your test kit has rivets placed for 120', 90', 80' and 70' swath widths.

Take care to use the correct rivets, per the Spread Pattern Test Procedure.



Fig. 38

Spreader Preparation

IMPORTANT! Before you begin spread pattern testing, make sure the spreader is in good mechanical condition and properly adjusted. Replace damaged or worn parts as needed.

Visual Check

Visually check your unit, paying close attention to the following parts:

- Waterfall assemblies
- Chutes
- Chute Bearings
- Spinner fin-overlays
- Spinner deflectors

Replace damaged or worn parts as needed.

Load Material

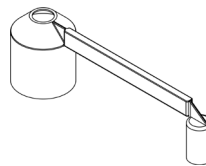

IMPORTANT! Have you measured your product density? If not, measure product density before loading material.

Once you've checked the product density, you may load material into the bin(s) you are testing.

NOTE: When measuring density with the scale provided in your spread pattern test kit, it is important to be consistent with how you fill the cup. For example, if you always level the cup without packing the material, follow this same method every time you measure density.

Spread Pattern Test Procedure Guidelines:

- **Wind:**
 - Velocity less than 5 MPH (8.05 km).
 - Travel parallel (within ± 15 degrees) to the wind direction.
- **Testing Area:**
 - 240 feet x 300 feet (37 m x 61 m)
 - Slope of less than two degrees.
 - See Fig. 39.
- **Do not** allow the loaded spreader to sit for more than one hour before testing.

Using the in-cab Controller, select the bin you are testing and follow the spread-pattern wizard. Refer to Fig. 39 as you complete the steps that follow:

1. Prepare Area and Position Spreader ([page 26](#))
2. Charge Conveyors ([page 27](#))
3. Follow Spread-Pattern Wizard ([page 28](#))
4. Evaluate Spread-Pattern Test Results ([page 30](#))

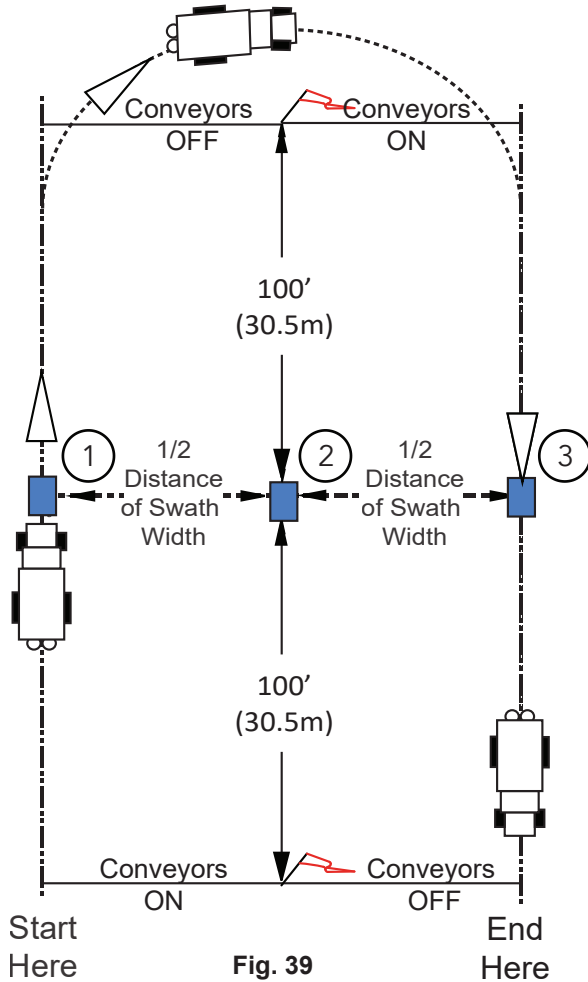

Fig. 39

1. Prepare Area and Position Spreader

- A. **Prepare Trays.** Place a white plastic grid in each blue tray.
- B. **Measure and Secure Rope.** Rivets mark tray placement for 120', 90', 80' and 70' swath widths.

Secure the rope (Fig. 40) to the ground with the stakes. **Take care to use the correct rivets.**

Note: You must carefully measure the required distances while maintaining proper alignment if you do not wish to use a rope. See Fig. 6 for proper measurements.



Fig. 40

- C. **Place Blue Trays.** Place Trays 1-3 as shown in Fig. 39.

D. Start Chassis.



E. Read and Understand Displayed Warning.

WARNING - DO NOT OPERATE ON ROADWAYS OR NEAR OBSTACLES

DO NOT in any way operate, program, or otherwise input information into this field computer while driving machinery on public or private roadways, in an area that contains obstacles, or where use of this field computer could distract from safe operation of the machinery and equipment. Doing so could lead to serious bodily injury and/or death.

The operator must monitor the machine while in operation. The operator is responsible for all damages resulting from the operator's failure to monitor the machine, including damages resulting from the operator's failure to monitor the machine during turns and automated turns.

When operating this field computer, you agree that it is solely your responsibility to make sure that the machinery and equipment are in an area clear of obstacles (including people) and located on a safe surface. You agree to remain in the driver's seat during any operation of the field computer. You agree that you are solely responsible for all claims for personal injury, death, or damage to property and you release Raven

BY CLICKING OK BELOW YOU AGREE TO THE ABOVE TERMS, AGREE YOU HAVE READ THE MANUAL FOR THIS FIELD COMPUTER, AND ALL ASSOCIATED MACHINERY, AND ARE ACCEPTING ALL RESPONSIBILITY FOR ANY LIABILITY THAT OCCURS DUE TO YOUR FAILURE TO COMPLY WITH THE ABOVE TERMS.

OK

- F. **Position Spreader.** The driving center must straddle Tray 1.

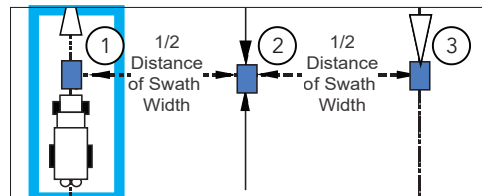

- G. **Enter Run Screen.**

>

See:

Total Width
120.000(ft)

PR1 OFF

PR2 OFF

Boundary Off
Boundary Off

Master ON
Quick Start

2. Charge Conveyors

IMPORTANT! Your spread pattern test results may not be accurate if you do not charge your conveyors.

1. Turn on Spinners.



C. Enable Master Switch.

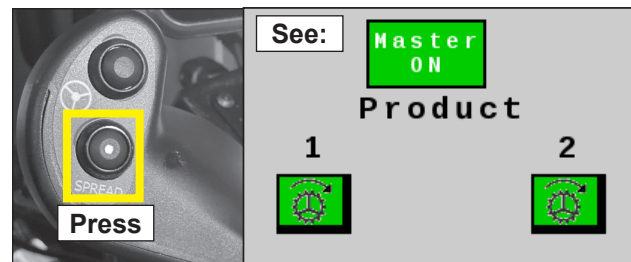

D. Charge Each Bin. Press and hold each Conveyor Bin icon until you see product in your rear-view mirror.

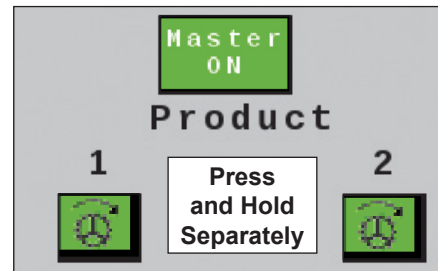

A. Set Up Rates. Enter or verify the highlighted fields for each bin:

- **Target Rate:** Lower # = Slower Conveyor
- **Product Density:** 45-75
- **Tank Product Type:** Any

Product 1 (Bin 1) = Lower Conveyors
 Product 2 (Bin 2) = Upper Conveyors

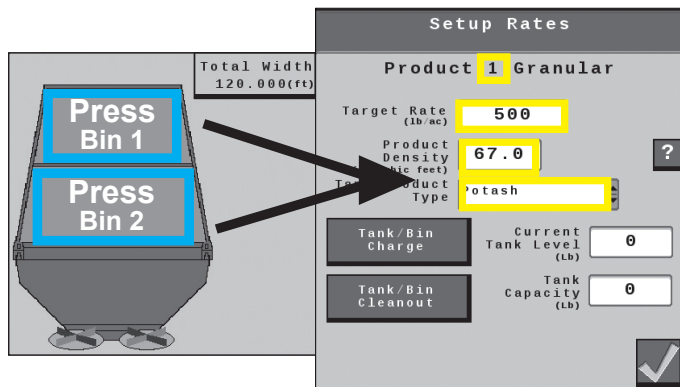

E. Disable Master Switch.

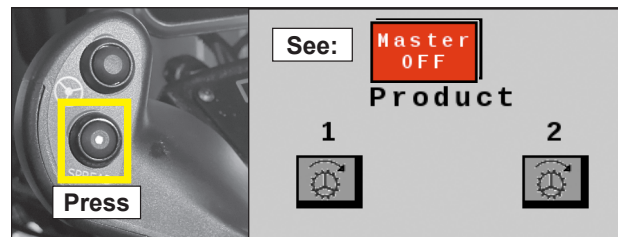

F. Complete Process. Select > Select again.

CAUTION Spinners are still running.

B. Select Tank/Bin Charge.

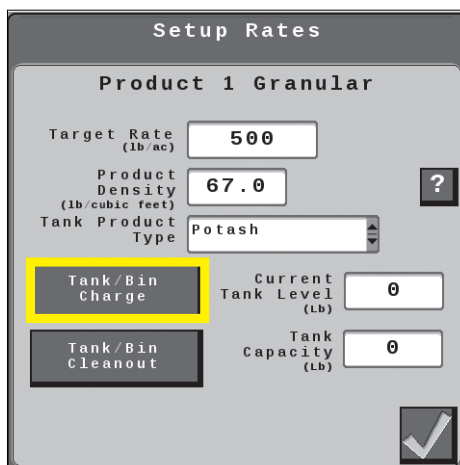

3. Follow Spread-Pattern Wizard.

A. **Select Relevant Bin.** (Bin 1 is selected as an example.)

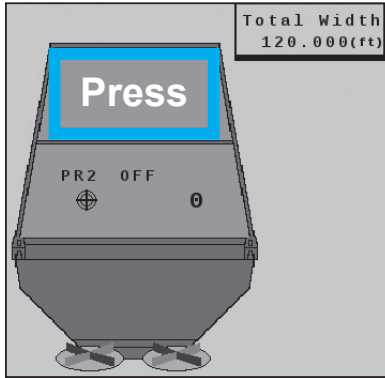

B. **Select New Tank Product Type.**

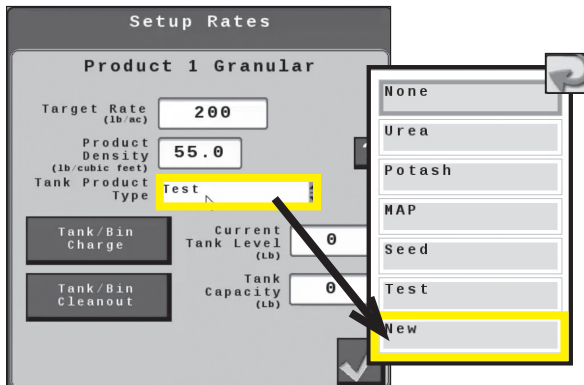

C. **Type New Product Name.**

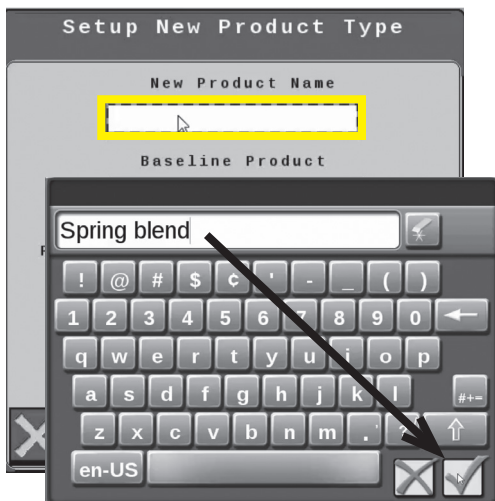

D. **Select Baseline Product.** Choose the option that most closely matches your product. > Return.



E. **Enter or adjust Product Density.**



F. **Read and Understand Displayed Warning.**

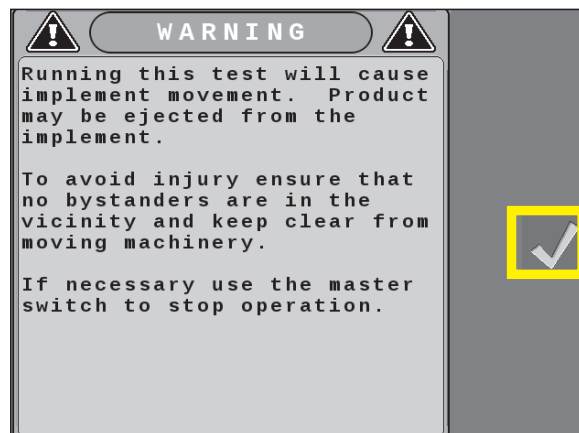

G. **Turn on Spinners.**



IMPORTANT! Did you charge your conveyors? If not, spread pattern test results may not be accurate. See "2. Charge Conveyors" on page 27.

IMPORTANT! DO NOT drive over the trays until both indicators are green or your spread pattern test results may not be accurate.

H. Drive Course. See below.

- Drive at 10–15 miles/hour.
- Enable and disable the Master Switch as illustrated.

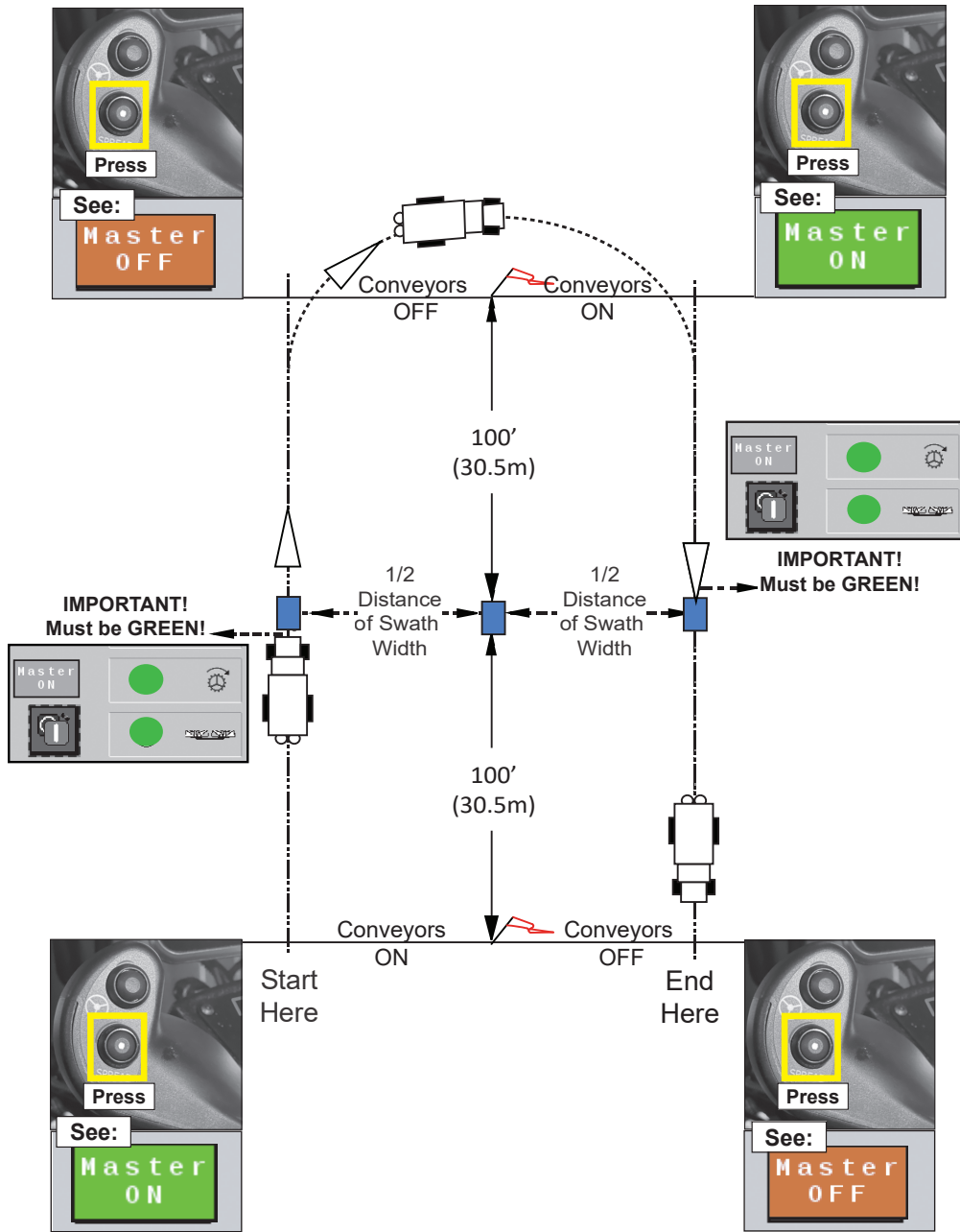

I. Turn off Spinners.

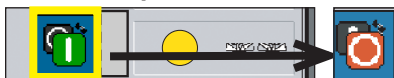

J. Park Chassis. Park in a secure location, and shut down the spreader. > Next



4. Evaluate Spread Pattern Test Results

A. **Funnel Contents into Tubes.** The center tray must be poured into the center tube.

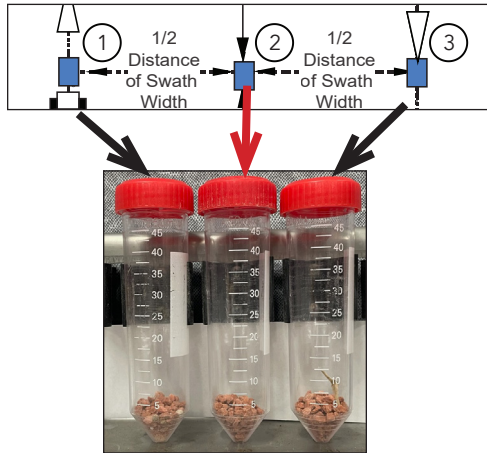

IMPORTANT! Adjustments to the spread pattern are automated based on the accurate input of the distribution of the material in the vials. Take care to select the correct option.

IMPORTANT! If an acceptable pattern is not achieved **within three passes**, contact NLM Product Sales and Support Department at 1-888-363-8006.

B. **Check Material Distribution.** Select the option that most closely matches your tubes; see examples below.

- If you did not achieve an acceptable pattern, return to Step G on page 28.
- If material is evenly distributed, press and continue to Step C on this page.

If an acceptable pattern is not achieved within three passes, contact NLM Product Sales and Support Department at 1-888-363-8006.

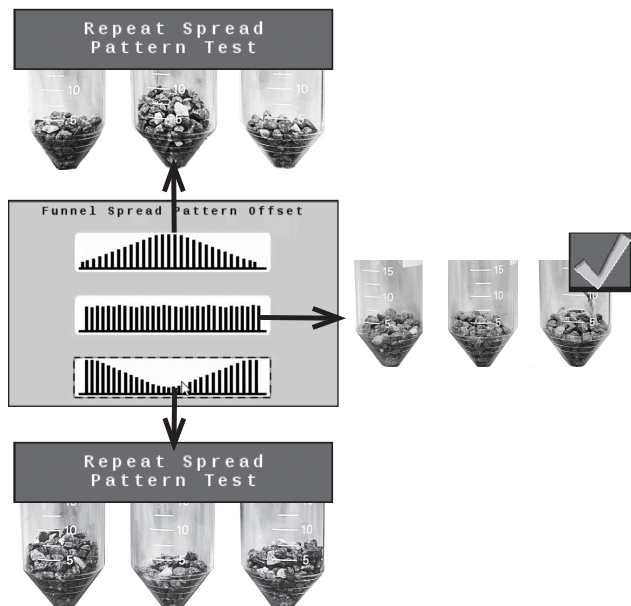

C. **Evaluate Tubes (Blended Product ONLY).**

Verify the blend is evenly distributed; see examples below. **If not spreading a blend:** Continue to Step E below.

a. **Acceptable Blend:** Continue to Step E below.

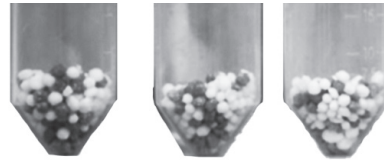

b. **Unacceptable Blend:** Indicates the presence of a limiting-factor product that cannot spread 120'. Save your profile.

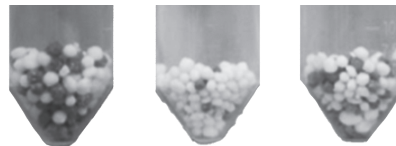

1. **Activate Profile.** See Step 2 on [page 31](#).

2. **Return to [page 26](#)** to adjust the placement of your trays. Take care to use the correct rivets and to update your Total Width.

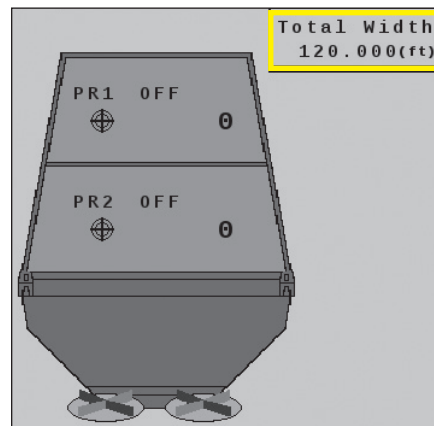

Call your Authorized Dealer or NLM Product Sales and Support Department at 1-888-363-8006 for support.

D. **Complete Process.** Select . > Select . >

Select Raven Home .

E. **Repeat Procedure If Needed.** Repeat "1. Prepare Area and Position Spreader" on [page 26](#) for each applicable product. **DO NOT** use the spread pattern wizard.

IV. Field Application

Fill bins and begin field application.

i. Start a Job

1. Enter Run Screen.

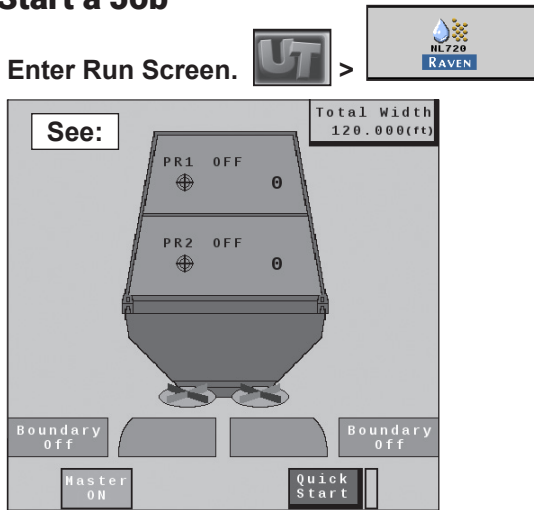

2. Verify Critical Product Characteristics. Verify Total Width, Target Rate, Product Density and Product Type.

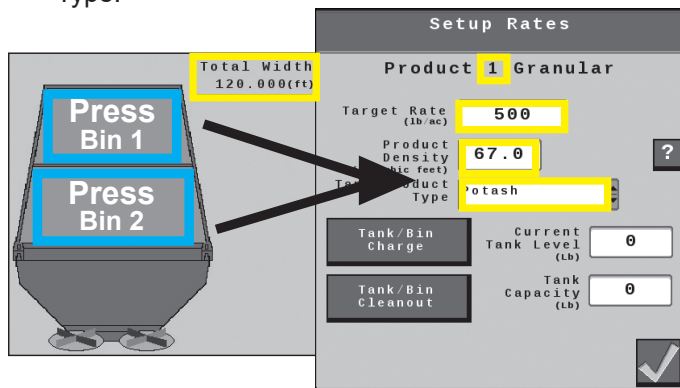

3. Start New Job.

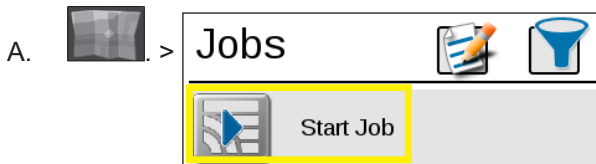

B. Verify or Enter Job Info.

- **Job Name:** Defaults to a date/time code.
- **Job Profile:** Start Job will change to "custom" after the next step.

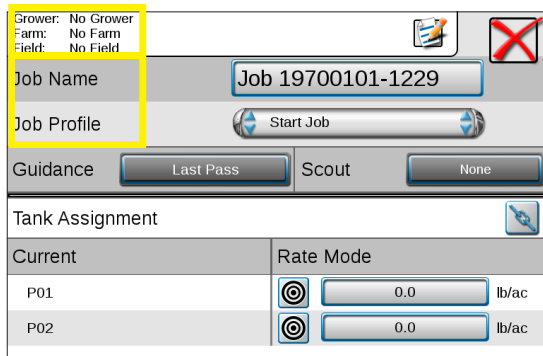

C. Select Guidance Type. Straight AB is used as an example.

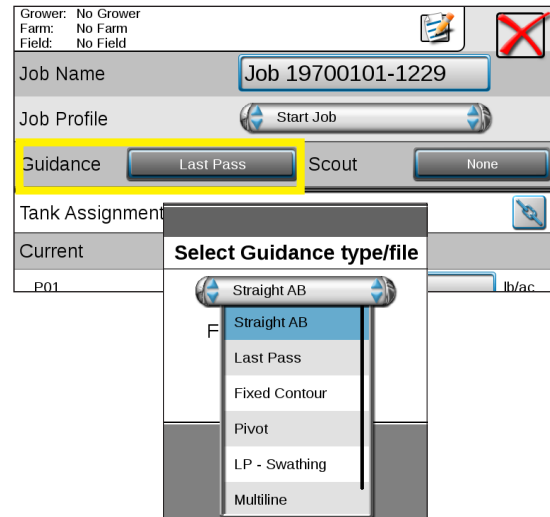

D. Select Scout if Boundary is Pre-loaded. If your boundary was pre-loaded, select the Scout tool.

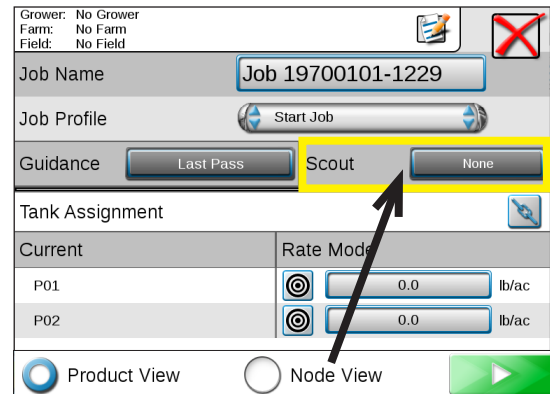

E. Enter Rate Mode. This is the Target Rate in pounds per acre (lbs/acre)

- PO1 = Bin 1
- PO2 = Bin 2

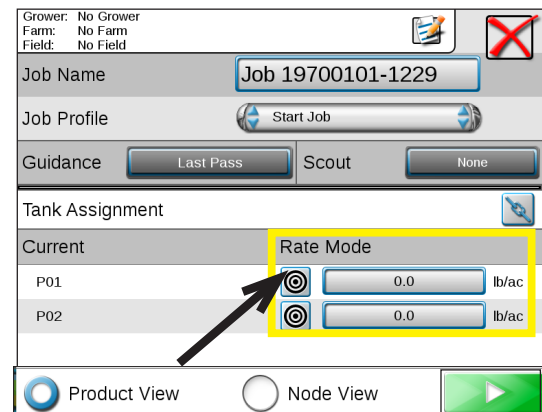

F. Press to enter Field Application.

4. **Read Notice.** Read and understand the Check Tank Product Type notice.



- B. **Activate Bins.** Press Main Bin, Insert Bin, Left Section & Right Section

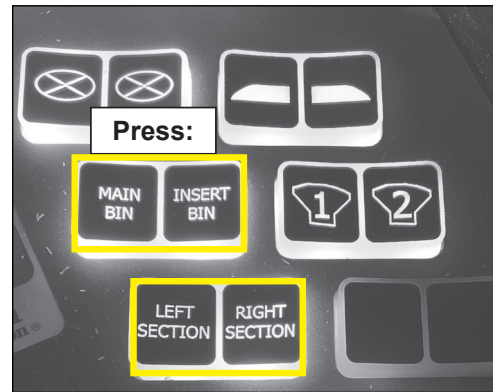

- C. **Activate Boundary Spread.** Press Left or Right Side > Return

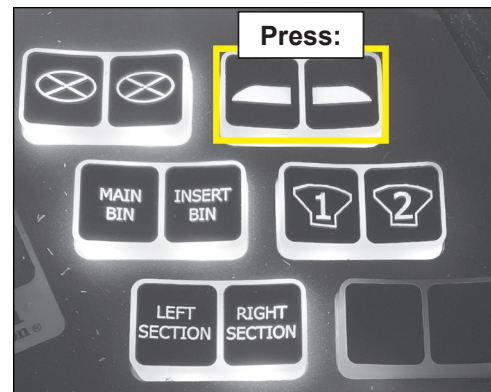

ii. Activate Boundary Spreading

1. **Check Setup Rates.** Check critical product characteristics if not already complete.

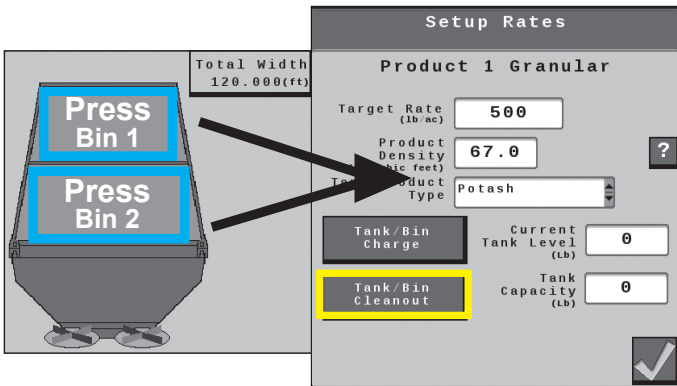

2. **Activate Unit.**

- A. **Verify Spinners are On.**

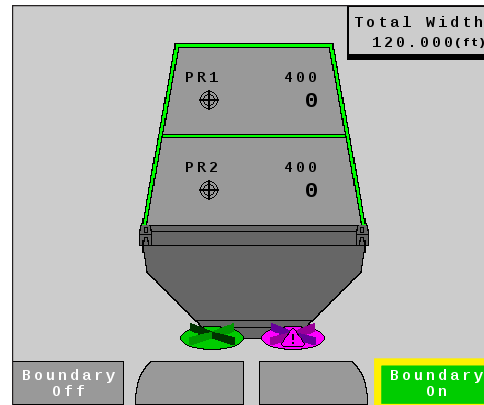
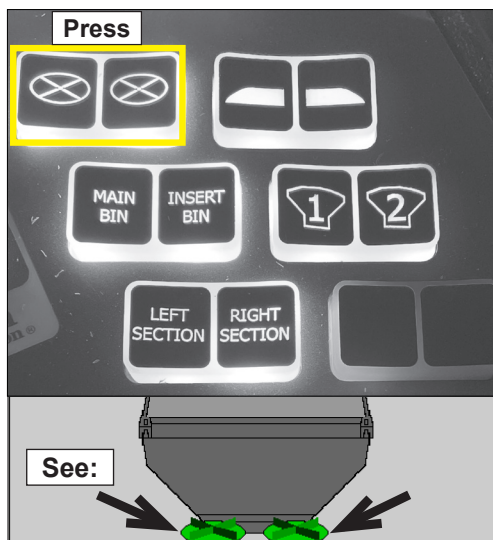

3. **Charge Conveyors.** See "2. Charge Conveyors" on page 27.

iv. Create Field Boundary

"Option 1: Record & Spread Boundary" on page 33.

"Option 2: Create Boundary From Coverage" on page 34.

"Option 3: Import Boundary" on page 34.

Option 1: Record & Spread Boundary

1. Select Scout Tool.



2. Enter Scout Tool Data.

- **Active Group** = Job Name
- **Scout Feature** = Field Boundary
- **Name** = Enter Name
- **Color** = Any Color (example = teal)
- **Point Recording Mode** = Auto Point Capture
- **Shift Recording Point** = Left, Center, or Right (Select the side the fence/boundary is on.)
- **Shift Distance** = Automatically populates based on Total Width.
- **Create Boundary From** = Work Order

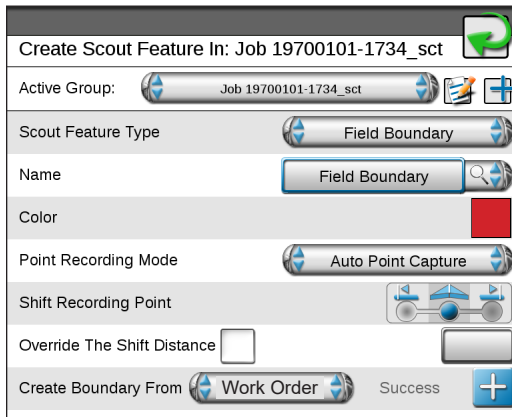

3. Begin Recording.

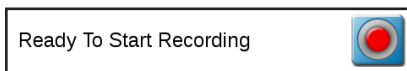

4. Select Record.



5. Start Conveyors. Press Master Apply Switch to begin spreading.



6. Read and Understand the Notice.

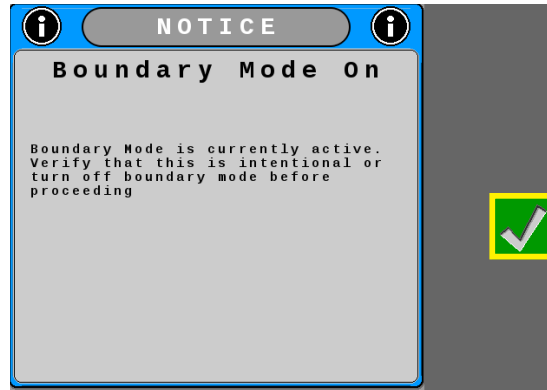

7. Map field. Drive the perimeter of the area you wish to spread.

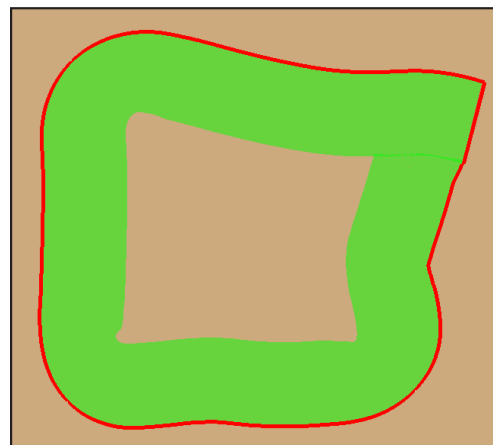

8. Stop Conveyors. Press Master Apply Switch to stop spreading.



9. Save Boundary. The area of the field will populate on the Scout Tool.



Option 2: Create Boundary From Coverage

IMPORTANT! Do not leave gaps in the boundary or this feature will not function properly.

1. **Spread Perimeter.** Spread the entire perimeter of the field with Boundary Spread activated.

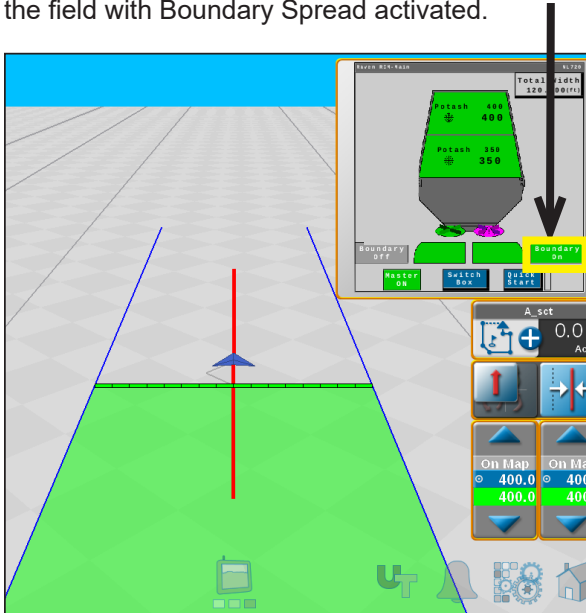

2. **Select Scout Tool.** When perimeter is complete, press the Scout Tool.

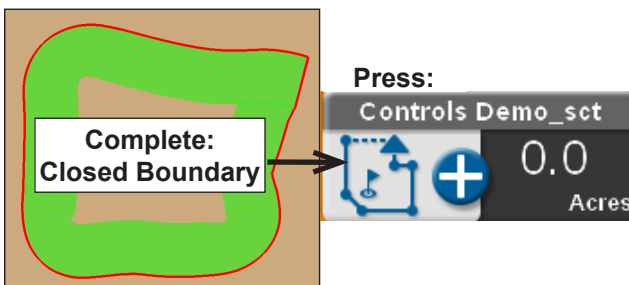

3. **Enter Scout Tool Data:**

- **Active Group** = Job Name
- **Scout Feature** = Field Boundary
- **Name** = Optional
- **Color** = Preferred Boundary Color
- **Point Recording Mode** = Auto Point Capture
- **Shift Recording Point** = Left, Center, or Right. (Select the side the fence/boundary is on.)
- **Shift distance** = automatically populated based on Total Width.
- **Create Boundary From** = Coverage

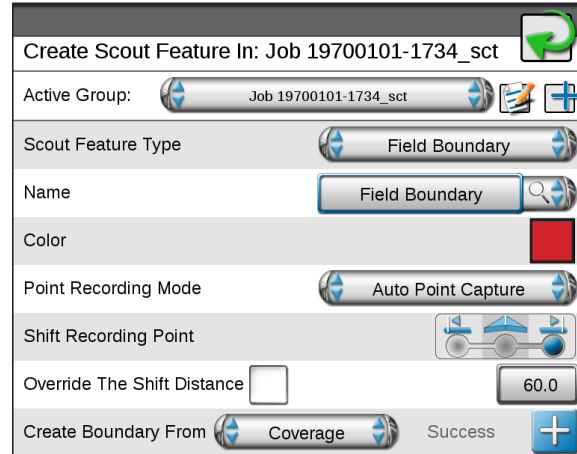

4. Press 

Option 3: Import Boundary

IMPORTANT! Do not activate Boundary spreading if you choose this option.

1. **Import Boundary.** Import your Boundary.
2. **Drive Boundary as Pictured.** Drive with two sections outside of the boundary line.

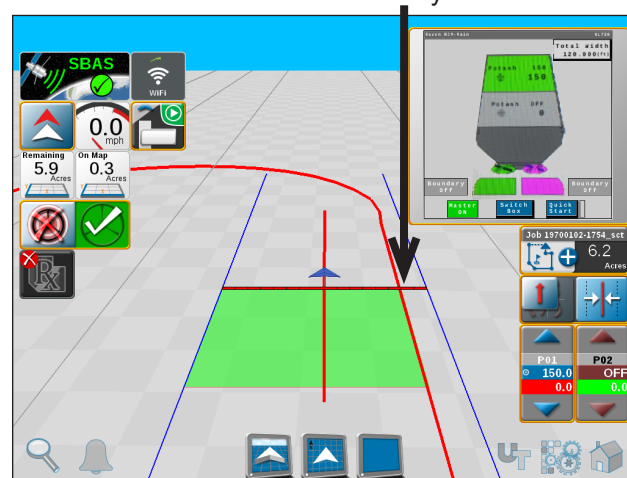

v. Begin Spreading

NOTICE Verify Boundary Mode is OFF if not needed, or you will misapply material.

1. Verify Boundary Mode is OFF.

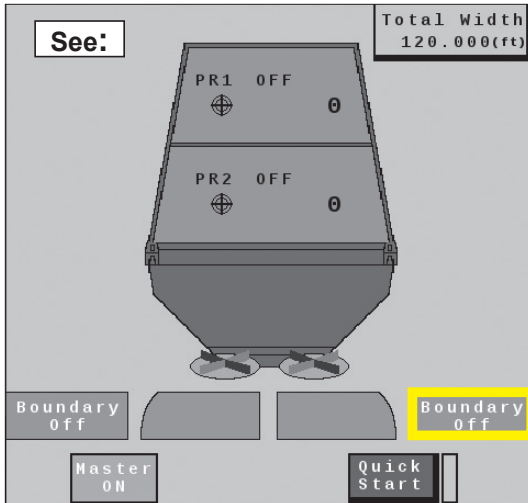
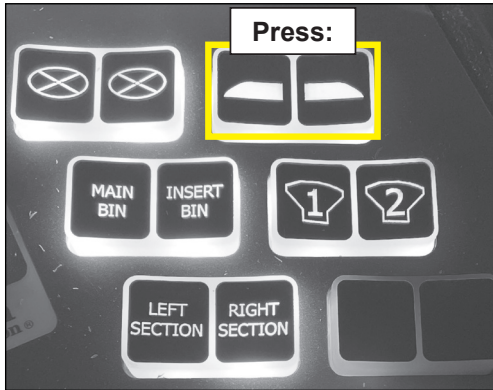

2. Verify Bins are activated and Spinners are on.

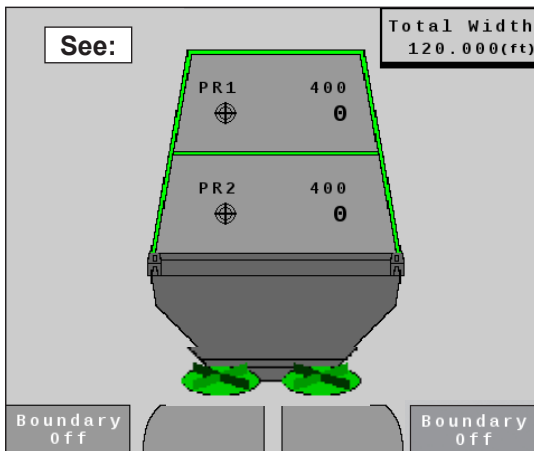

3. **Begin Applying.** Press Master Apply Switch to begin spreading.



4. **Spread the Entire Field.** This step covers the AB-Guidance. For other options, please consult your Raven manual.

- A. **Tap Guidance Widget.**



- B. **Select Straight (AB)**

- C. **Tap A. > Drive Straight. > Tap B.**

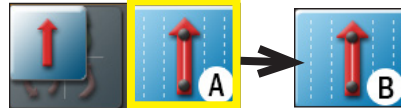

- D. **Line Up Guidance and Engage Auto Steer.** Auto steer will disengage when turning into headlands.

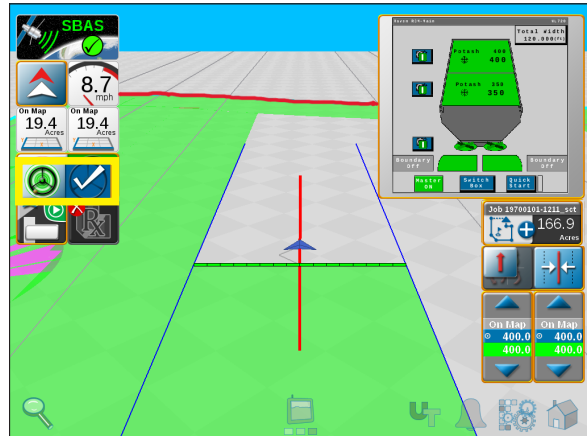

5. **Close Job.** When entire field is spread, close the job.

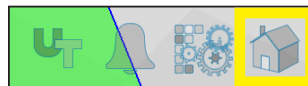

6. **Park Chassis.** Park in a secure location and shut down the spreader.

V. Tank Clean Out

1. **Remove Waterfall Covers.** Disassemble from top to bottom. Red arrows point to cutouts that show each part's location. Refer to cutouts when you reassemble the waterfalls.

See "Waterfalls" on page 41 for additional instructions.

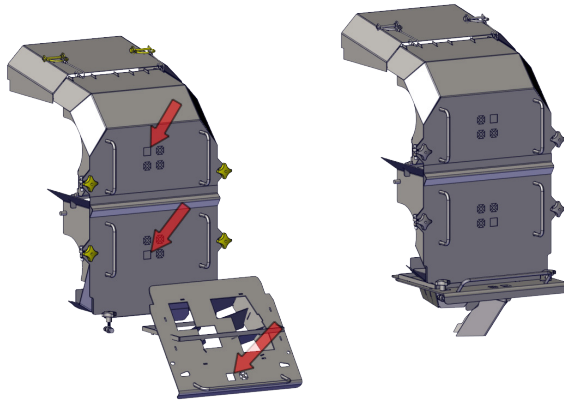

1. **Navigate to Bin/Tank Cleanout.** Press Either Bin > Select Tank/Bin Cleanout.

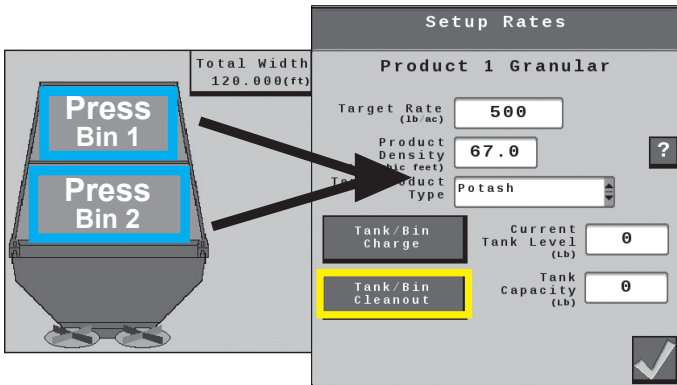

2. **Accept Warning.** Read and acknowledge your understanding of the displayed warning.

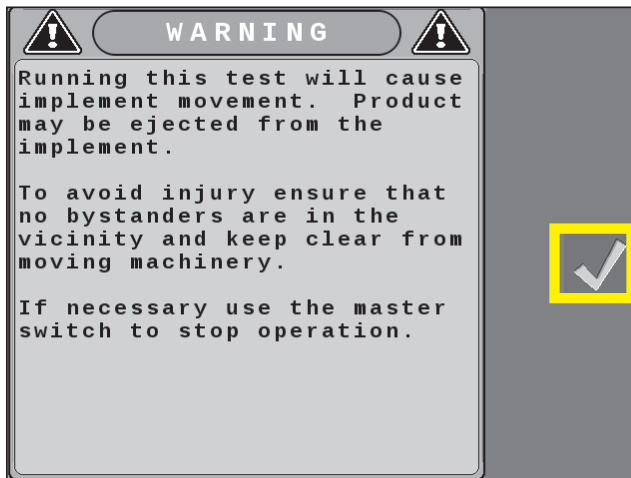

3. **Select Relevant Bin(s).** You may clean out multiple bins at the same time. **DO NOT** select

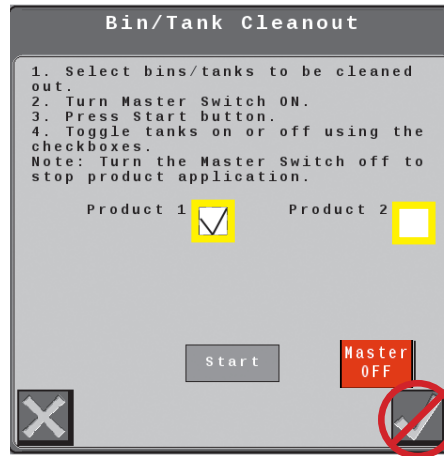

4. **Turn on Master Switch.**

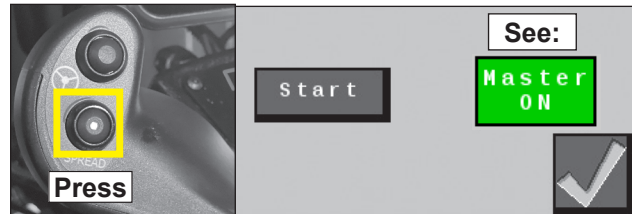

5. **Press Start.** The running person appears when the conveyors are running.

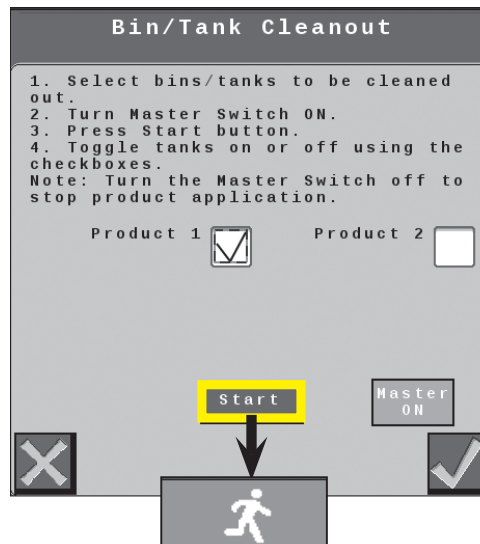

6. **Read Warning.** If running at max speed, read and acknowledge the displayed warning.

7. **Complete Process.** Stop Conveyors when tank is empty. > Complete Process.



⚠ WARNING Shut off all power and allow all moving parts to come to rest before performing any maintenance operation.

NOTICE The lubricant distributor and/or supplier is to be held responsible for results obtained from their products. Procure lubricants from distributors and/or suppliers of unquestionable integrity, supplying known and tested products. Do not jeopardize your equipment with inferior lubricants. No specific brands of oil are recommended. Use only products qualified under the following oil viscosity specifications and classification recommended by reputable oil companies.

Lubrication & Maintenance

Preventative Maintenance Pays!

The handling and spreading of commercial fertilizers is a most severe operation with respect to metal corrosion.

Establish a frequent, periodic preventative maintenance program to prevent rapid deterioration of the spreading equipment. Proper cleaning, lubrication and maintenance will yield longer life, more satisfactory service and more economical use of your equipment.

Hydraulic System

NOTICE DO NOT attempt to run the pump without first filling the hydraulic reservoir and opening the suction line valve, or damage to the pump may occur.

Proper oil in the hydraulic system is one of the most important factors for satisfactory operation. The utmost cleanliness in handling the oil cannot be stressed enough. Keep hydraulic oil in original closed containers, clean the top of the container before opening and pouring, and handle in extremely clean measures and funnels.

Check hydraulic oil level and filter condition regularly.

Refer to "[Lubricant Specifications](#)" on page 42 for the selection of the proper hydraulic fluid for use in the hydraulic system.

⚠ WARNING DO NOT check leaks with hands while system is operating as high pressure oil leaks can be dangerous! If skin is pierced with hydraulic fluid at high pressure seek immediate medical attention as fluid injected into the skin could cause gangrene if left untreated. Relieve pressure before disconnecting hydraulic lines or working system. Make sure all hydraulic fluid connections are tight and all hydraulic hoses and lines are in good condition before applying pressure to the system. Wear protective gloves and safety glasses or goggles when working with hydraulic systems.

⚠ WARNING To avoid entanglement, DO NOT check for leaks next to moving parts while the system is operating!

Periodically inspect hydraulic hoses and fittings for leaks. Repair and replace components as necessary.

Check hydraulic oil daily by means of a sight gauge on the reservoir. Add oil as necessary to maintain a level around the mid-point of the sight gauge. Periodically inspect hoses and fittings for leaks.

NOTICE CHANGE HYDRAULIC OIL FILTER AFTER FIRST WEEK (OR NOT MORE THAN 50 HOURS) OF OPERATION ON A UNIT.

After the first filter change, replace the filter when the indicator reaches the Red Zone.

Drain reservoir through drain plug (not through suction outlet), flush, and refill and change filter element annually. Oil and filter should also be changed whenever oil shows any signs of breaking down under continued high-pressure operation. Discoloration of oil is one sign of breakdown.

Filling Hydraulic System

Fill the reservoir with hydraulic oil as specified in the "Lubrication and Maintenance" section in the operator's manual. Be sure the oil is clean and free from dirt, water and other contaminants.

Hydraulic Hoses

Hose assemblies in operation should be inspected frequently for leakage, kinking, abrasion, corrosion or other signs of wear or damage. Worn or damaged hose assemblies should be replaced immediately.

⚠ WARNING Testing should be conducted in approved test stands with adequate guards to protect the operator.

Clean

Fig. 41: Clean assembly by blowing out with clean compressed air. Assemblies may be rinsed with mineral spirits if the tube stock is compatible with oil. Otherwise, rinse with hot water at 150°F (65.55° C) maximum.

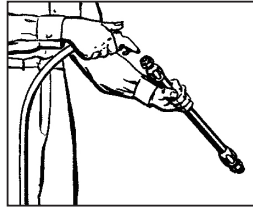

Fig. 41

Inspect

Fig. 42: Examine hose assembly internally for cut or bulged tube, obstructions, and cleanliness. For segment style fittings, be sure that the hose butts up against the nipple shoulder; band and retaining ring are properly set and tight, and segments are properly spaced. Check for proper gap between nut and socket or hex and socket. Nuts should swivel freely. Check the layline of the hose to be sure the assembly is not twisted. Cap the ends of the hose with plastic covers to keep clean.

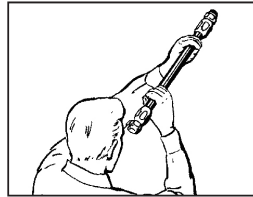

Fig. 42

Test

Fig. 43: The hose assembly should be hydrostatically tested at twice the recommended working pressure of the hose.

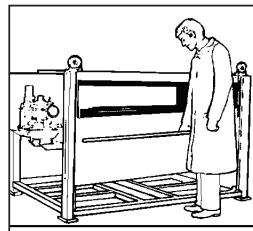

Fig. 43

Test pressure should be held for not more than one minute and not less than 30 seconds. When test pressure is reached, visually inspect hose assembly for: (1) Any leaks or signs of weakness and (2) Any movement of the hose fitting in relation to the hose. Any of these defects are cause for rejection.

Storage and Handling

Hose should be stored in a dark, dry atmosphere away from electrical equipment, and the temperature should not exceed 90° F (32° C).

Hydraulic Hose Installation

If you need to route hoses for maintenance or installation, please refer to the manual for your tractor/chassis.

For reference, Fig. 44 and Fig. 45 show the hydraulic hookups on the spinner control valve and the conveyor control valves. Both valves are located on the exterior of the unit, in between the conveyors.

Spinner Control Valve

Fig. 44: Connect your hydraulic hoses to the appropriate port(s), as shown below:

- A. Return
- B. Pressure Control
- C. Load Sense

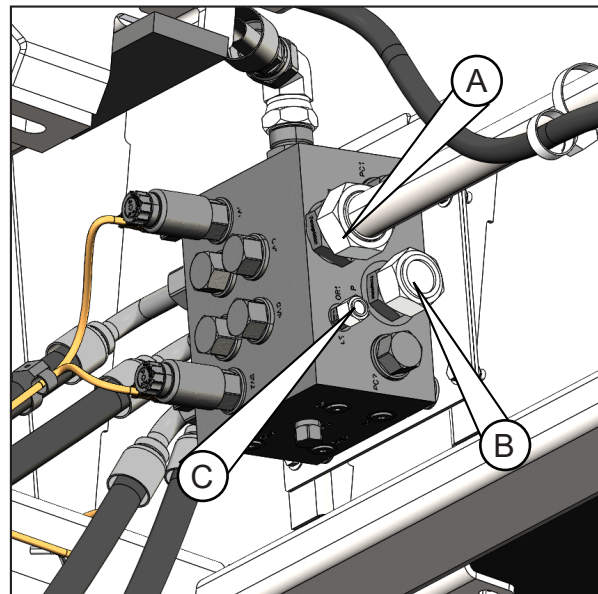

Fig. 44

Conveyor Control Valve

Fig. 45: Connect your hydraulic hoses to the appropriate port(s), as shown below:

- A. Return
- B. Pressure Control
- C. Load Sense

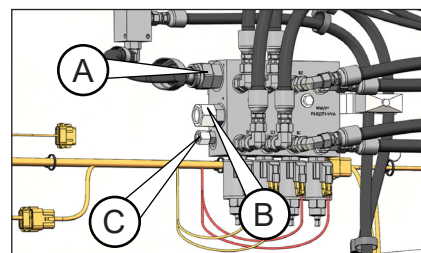

Fig. 45

See "[Hydraulic Hose Installation: General Information](#)" on [page 22](#) for general guidelines about properly routing and tensioning hydraulic hoses. (Instructions are used with the permission of The Weatherhead Company.)

NOTICE Over-tensioning of conveyor belt will lead to excessive load on the system, causing excessive belt and sprocket wear and can cause extremely high starting pressures. Under-tensioning will result in interrupted flow of material to the spinners.

Conveyor Belt

WARNING Stay out of the hopper body. If it's necessary to enter the hopper, return to the shop, empty body, turn off all power, set vehicle brakes, lock engine starting switch and remove keys before entering. Tag all controls to prohibit operation. Tags should be placed, and later removed, only by person working in the body.

Hose down unit and remove any material build-up.

NOTICE The conveyor will move away from the bottom panel if material accumulates under the conveyor or on the sprockets. Do not remove material while conveyor or spinner is running!

Proper Conveyor Belt Tension

Fig. 46 and **Fig. 47** show the proper tensioning of the conveyor belts. Proper belt tension is a factor in belt and sprocket life.

Bin 1 Conveyor Belts (Fig. 46): The lowest part of the lower conveyor belts should rest 1/2" above the bottom of the sills.

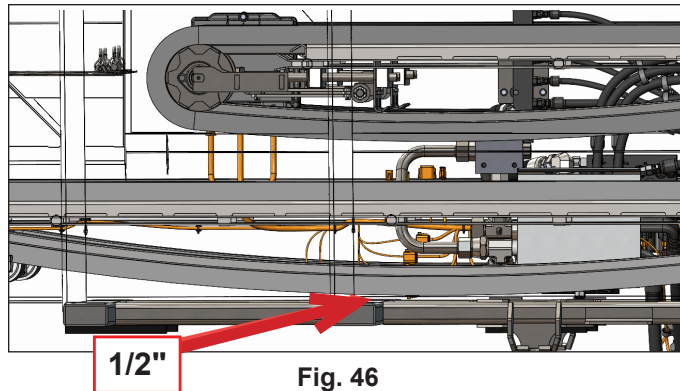

Fig. 46

Bin 2 Conveyor Belts (Fig. 47): The lowest part of upper belt should touch the middle of the angled surface of the chain shield.

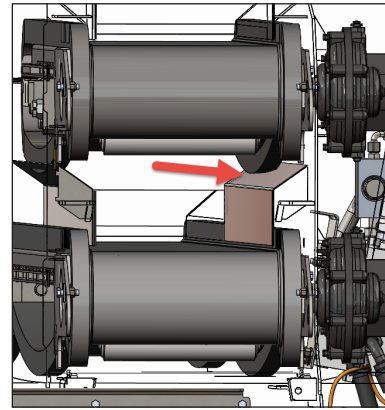

Fig. 47

NOTICE Over-tensioning the conveyor belts can cause high starting pressures and lead to excessive belt wear and premature failure.

Adjusting Conveyor Belt Tension

Conveyor belt adjustments are made by turning the idler screws on each side of the unit – clockwise increases tension and counterclockwise decreases tension. Adjust idlers equally on both sides.

Fig. 48 shows the location of the Bin 1 and Bin 2 idler screws.

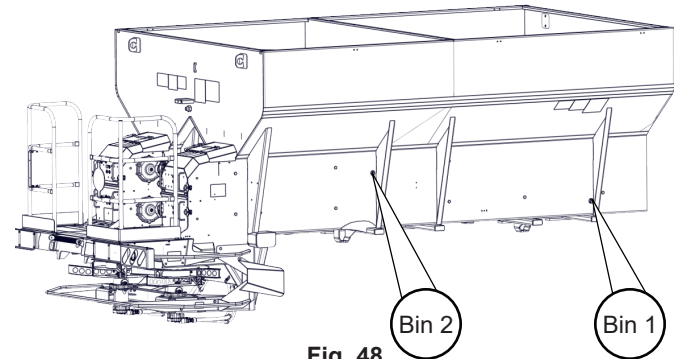

Fig. 48

Electrical Connections

Connect all electrical control circuits. All wiring should be approved automotive insulated wire, supported adequately with insulating ties or straps, and located where it will not interfere with any control or access. Make sure the wiring does not contact any moving parts or sharp edges and is kept away from any hydraulic line or any heated part.

ISOBUS Connections

Fig. 49 shows the location of the electrical connections on your unit.

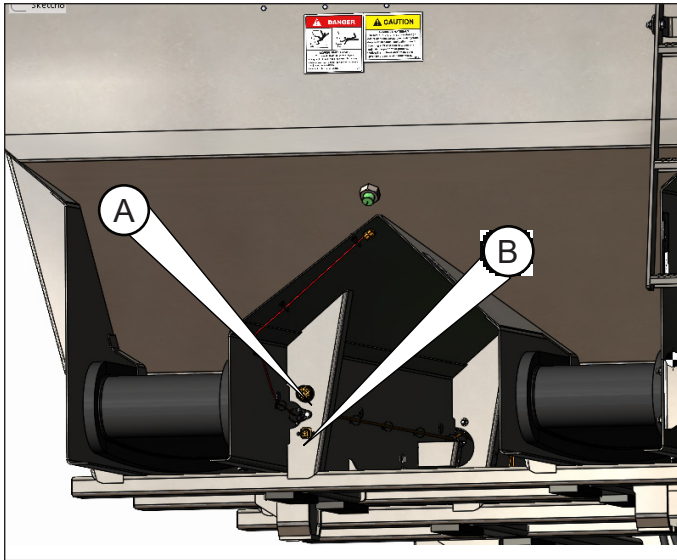

Fig. 49

Fig. 49, Connection A:

- Pin 1: Battery Ground
- Pin 2: ECU Return (ECU Ground)
- Pin 3: 60-amp fused power
- Pin 4: ECU Power (Switched 12v)
- Pin 5: Not Used
- Pin 6: ISO-CAN Return
- Pin 7: ISO-CAN Return
- Pin 8: ISO-CAN High
- Pin 9: ISO-CAN Low

Fig. 49, Connection B:

- Pin 1: Hydraulic cooler fan power (Switched 12V)
- Pin 2: Hydraulic cooler fan ground
- Pin 3: Aux Power
- Pin 4: Aux Ground

Clean-Up

NOTICE

Use caution when cleaning the control components! High-pressure wash can inject water or fertilizer into these components, causing damage.

Thoroughly wash the unit every two to three days during the operating season to maintain minimal maintenance operation. Hose the unit down under pressure to free all sticky and frozen material.

It is important to thoroughly clean the unit at the end of each operating season. All lubrication and maintenance instructions should be closely followed. Repaint worn spots to prevent the formation of rust.

Fin-Overlays

Eight removable fin-overlays (Fig. 50) broadcast material into the field from the unit. Inspect each fin-overlay and spinner assembly periodically throughout the day for buildup and holes. Even a small build-up of material or hole can significantly affect the spread pattern.

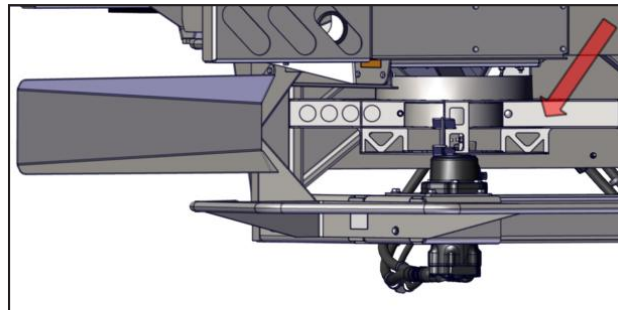

Fig. 50

Replace fin-overlays immediately when a hole is detected (Fig. 51). In addition to causing a poor spread pattern, holes in the fin-overlays will prematurely damage the spinner disc weldment.



Fig. 51

Spinner Deflectors

Inspect spinner deflectors (Fig. 52) daily for build-up of material and damage.

Clean as needed. Even a small build-up of material on a spinner deflector can affect the spread pattern.

Replace as needed if damaged, bent or otherwise altered.

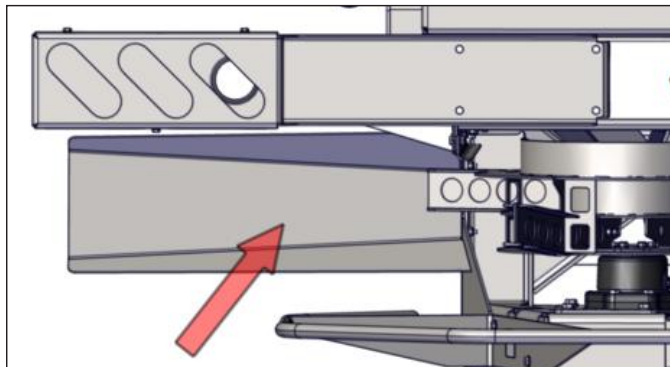

Fig. 52

Conveyor Gearcase

Drain oil in a new unit after first two weeks (or not more than 100 hours) of operation, and flush gear case thoroughly with light oil.

Refer to ["Conveyor Gearcase Lubrication Instructions"](#) on page 43 for proper grade oil and recommended amounts of lubricant.

After initial change, oil should be changed every 2,000 hours of operation or annually, whichever occurs first. Check gearcase oil level monthly.

Waterfalls

⚠ WARNING	Do not enter the platform if the unit is running. Shut off all power and allow all moving parts to come to rest before approaching the waterfalls.
------------------	--

NOTICE	Before transporting or operating the unit, inspect and tighten all knobs and verify that pins are secured.
---------------	--

Waterfalls (Fig. 53) must kept clean. Inspect daily for build-up of material and wear. Even a small build-up of material can significantly affect the spread pattern.

Disassemble each waterfall in order from top to bottom by using tool-free access pins and knobs (in yellow). The red arrows in Fig. 53 point to the cutouts that illustrate the location of each removable part. The top (hat) is anchored to the unit with a cord.

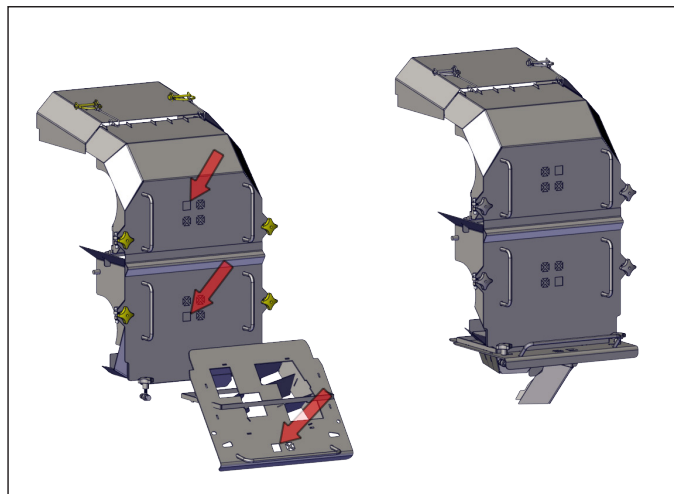

Fig. 53

Chutes

Four chutes (two upper; two lower) are accessible via the waterfall. You must disassemble the waterfall in order to inspect the chutes (Fig. 54) daily for build-up or blockages of material. Remove any excess material and clean chutes prior to operation. Replace chutes as needed if damaged, bent or otherwise altered.

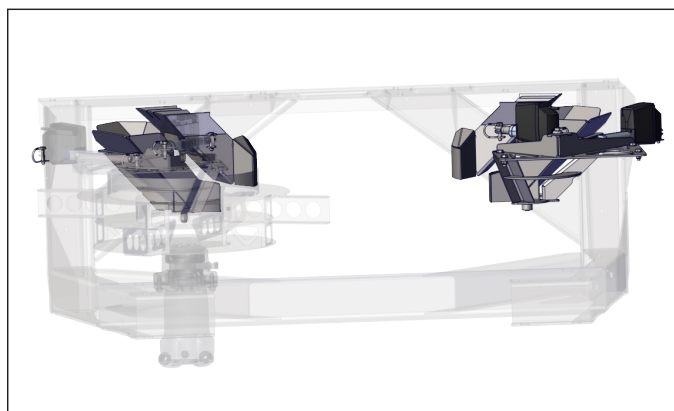

Fig. 54

Chute Bushings

Two bushings per spinner assembly (Fig. 55) enable chute mobility, which is essential to spreader function. Even a small alteration due to damage or wear can significantly affect the spread pattern.

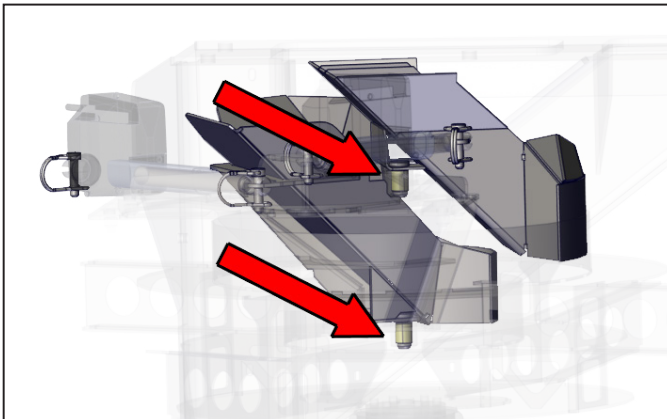

Fig. 55

Inspect bushings daily by removing the chutes via the waterfall floor (Fig. 56). Replace immediately if cracked, broken, missing, or otherwise altered.

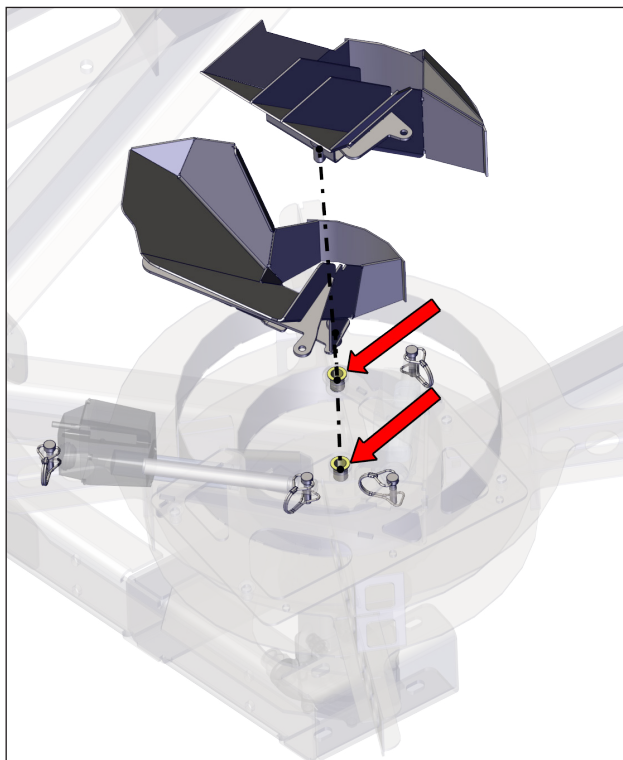

Fig. 56

Bin Sensor

WARNING

Stay out of the spreader. Do not climb on spreader. Use a portable ladder to inspect, clean and maintain the bin sensor from outside the spreader. Failure to do so could result in injury from falling.

NOTICE

Wipe sensor clean periodically to prevent accumulation of product. Avoid wet material as it may stick to sensor. If material sticks to sensor it won't warn user when bin is low.

Clean sensor with long handled brush or hose from outside of spreader. Do not aim high pressure sprayer directly at sensor—it could damage the components.

Hydraulic System Lubrication

NOTICE

The lubricant distributor and/or supplier is responsible for the results obtained from their products. Procure lubricants from distributors and/or suppliers with unquestionable integrity, supplying known and tested products. Do not jeopardize your equipment with inferior lubricants. No specific brands of oil are recommended. Use only products qualified under the following oil viscosity specifications and classifications and recommended by reputable oil companies.

Use premium quality lubricants with 100–200 SUS or 20–43 CST viscosity at operating temperatures. The hydraulic fluid's specifications in the table below are for normal operating conditions.

Extreme environments or dirty conditions may require the use of different oils.

Consult your authorized dealer or the Product Support Department at New Leader Manufacturing for systems operating outside normal conditions.

Lubricant Specifications

Ideal Oil Operating Temp	115-158°F (46.11-70° C)
Recommended Premium Lubricant	Multi-Purpose
Viscosity Index Viscosity at 40°C, CST Viscosity at 100°C, CST	Greater than 130 Less than 68 Greater than 9
Acceptable Fluid Example	Mobil 424

Conveyor Gearcase Lubrication Instructions

1. Drain oil in a new unit after the first two weeks (or not more than 100 hours) of operation and flush the gear case thoroughly with light oil. See the oil grade and lubricant recommendations the following table:

Ambient Temp	Oil Type
Below 40°F (4.4°C)	SAE 80 E.P.
40° - 100° F (4.4° - 38° C)	SAE 90 E.P.
Above 100° F (38° C)	SAE 140 E.P.

2. After the initial change, oil should be changed every 2,000 hours of operation or annually, whichever occurs first. Check gearcase oil level monthly.
3. Fill the gearcase with non-corrosive type extreme pressure (E.P.) gear oil conforming to MIL-L2105 B multi-purpose gear lubricating oil requirements (API Service GL 4) based on ambient temperatures listed below:
 - A. Single Pinion: 1 Pint (.50 L)
 - B. Dual Pinion: 1.5 Pints (.70 L)

WARNING Shut off all power and allow all moving parts to stop before performing any maintenance operation.

The spreader should be regularly lubricated with the lubricants recommended in this manual per the following chart:

Location	Places	Method	Frequency
Hydraulic System			
Reservoir	1		Check Daily. Change Annually
Filter	1		Check daily; Change when indicated (Red)
Conveyor			
Gearcase	2-4	Gear Oil	Check Monthly; Change Annually

NOTE: Unusual conditions, such as excessive dust, temperature extremes or excessive moisture may require more frequent lubrication of specific parts.

*See "Lubricant Specifications" on page 42 for types of lubricants and oil to be used.

Standard Torques

Cap Screw Grade Identification – Markings on Head:

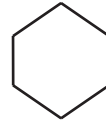

SAE Grade 2: No Marks



SAE Grade 5: Three Marks – 120 Degrees Apart

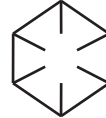

SAE Grade 8: Six Marks – 60 Degrees Apart

Capscrew Size	Torque - Ft. - Lbs.					
	Grade 2		Grade 5		Grade 8	
	Dry	Lube	Dry	Lube	Dry	Lube
1/4"	5	4	8	6	12	9
5/16"	11	8	17	13	25	18
3/8"	20	15	30	23	45	35
7/16"	30	24	50	35	70	55
1/2"	50	35	75	55	110	80
9/16"	65	50	110	80	150	110
5/8"	90	70	150	110	220	170
3/4"	100	120	260	200	380	280
7/8"	140	110	400	300	600	460
1"	220	160	580	440	900	650

Troubleshooting

If you encounter symptoms not listed or issues that require testing and further assessment, please contact your authorized dealer.

Symptom	Reason	Correction
Spinner will not turn on	No voltage at valve	Verify spinner switch is on.
		Verify controller has a target spinner RPM entered.
		Verify spinner control harness is not damaged.
	No hydraulic flow	Verify hydraulics are on.
Flow test pump – replace as needed.		
Spinner will not shut off	Defective spinner control valve	Replace spinner control valve cartridge.
	Control valve was manually override	Loosen jam nut on control valve cartridge and back set screw out until spinner stops.
Spinner runs erratically	Defective spinner speed sensor	Replace spinner speed sensor.
Spinner speed does not hit target	Defective spinner control valve	Replace spinner control valve cartridge and coil.
	Pump failure	Flow and pressure test pump.
	Spinner product control harness failure	Replace spinner product control harness.
	Spinner speed sensor failure	Replace spinner speed sensor.
Conveyor will not run	No voltage at valve	Verify bin switch, section switch and master switches are all on.
		Verify product control harness is not damaged.
	No hydraulic flow	Verify hydraulics are on.
		Flow test pump – replace as needed.
Conveyor will not shut off	Defective conveyor cartridge	Replace conveyor control valve cartridge and coil.
Hydraulics over-heating	Hydraulic cooler is not running	Check relay and thermostatic switch on cooler assembly.
Bin level sensors not working properly	Not enabled	Verify system was configured with bin level sensors installed.
	Bin level sensor failure	Replace sensor.
	Bin level sensor harness failure	Replace product control harness.
	Sensor may need adjustment	Call local dealer for adjustment procedure

Hydraulic Flow Chart

