



MODEL E1888
Operator's/Parts Manual

UNIT SERIAL NUMBER _____

MANUAL NUMBER: 84660-K

EFFECTIVE 01/2025



1330 76TH AVE SW
CEDAR RAPIDS, IA 52404-7052
PHONE (800) 363-1771 | FAX (319) 286-3350
www.newleader.com

Copyright 2023 New Leader Manufacturing

Table of Contents

Table of Contents	2
Interactive Features	4
Warranty	6
Preface	7
Safety	8
Important Safety Information	8
Safety Alert Symbols	8
General Safety Rules	9
Safety Decals.....	19
Safety Decal Maintenance.....	19
Safety Decal Installation	19
Informational Decals	23
Installation Instructions	25
Unpacking.....	25
Truck Requirements.....	25
Truck Frame Length	25
Lifting the Spreader	26
Installing Body.....	27
Wear Strips.....	27
Positioning Body	27
Installing Mounts.....	28
Securing Body to Frame	28
Cab Shield Installation.....	29
Spinner.....	30
Spinner Chute Installation	30
Hydraulic Hose	32
Installation Guide	33
Electrical Connections	34
Lights.....	34
Filling the Hydraulic System	34
Checking Installation.....	34
Operations.....	35
General Description	35
Dimensions & Capacities	36
Initial Start-Up	37
General Operating Procedures	38
Spring Loaded Idler.....	39
Maintenance	40
Preventative Maintenance Pays!	40
Hydraulic System.....	40
Service Schedule	40
Lubrication and Maintenance.....	40
Hydraulic Hose	41
Storage and Handling.....	41
Conveyor Chain.....	42
Conveyor Replacement	43
Removal.....	43
Installation.....	43
Conveyor Gearcase.....	44
Lubrication of Bearings.....	44
Fasteners.....	44
Clean-Up	44



Table of Contents Continued

Lubricant and Hydraulic Oil Specifications.....	45
Hydraulic System.....	45
Gearcase Lubricant.....	46
Grease Gun Lubricant.....	46
Lubrication Chart.....	47
Standard Torques.....	48
Parts	50
Instructions for Ordering Parts.....	50
Body & Subframe.....	51
Mounting Kit.....	53
Bumper.....	54
Cab Shield.....	55
Fenders.....	59
Stone Shields.....	61
Shovel/Broom Mount.....	62
Frame Cover.....	63
Hydraulic Reservoir.....	64
Feedgate & Jack.....	65
Feedgate Assembly.....	66
Clump Diverter.....	68
Conveyor Idler.....	69
Conveyor Drive.....	70
#1 Conveyor Chain.....	71
Spinner.....	72
Pre-Wet Calcium Reservoir.....	74
Pre-Wet Pump & Fittings.....	75
Decals.....	76



NOTE:

This manual incorporates several interactive features to provide supplemental information and ease of navigation. The information below is to aid in the identification and use of these features.

Hyperlinks

Hyperlinks provide direct access to a specific destination when clicked. The entire Table of Contents of this manual is hyperlinked to provide quick access to all sections of this manual when viewing the electronic version.

Hyperlinks within the content are denoted by **blue, bold underlined text**. Electronic format viewers can click these links for direct access to New Leader online features. Internet access is required.

This page is intentionally left blank.

HI-WAY LIMITED WARRANTY

BASIC WARRANTY

HIGHWAY EQUIPMENT COMPANY ("Highway") has manufactured or is distributing the Product/Genuine Parts to which this warranty is attached, and warrants to its original reseller including Dealers, Distributors and Original Equipment Manufacturers (hereafter called Dealer) that the Product/Genuine Parts will, under normal conditions of use and service, be free from material defects due to faulty manufacturing for a period of six (6) months from the date of delivery to the original user. For any Product/Genuine Part that does not conform to the aforesaid warranty within six (6) months from the date of delivery to the original user, your Dealer will, at its option, repair or replace parts. Labor costs for this basic warranty coverage will be paid by Highway to the Dealer at their standard shop rate, based on the amount of time Highway establishes to be the time reasonably necessary to make required repairs. If the Product/Genuine Part is defective in materials or workmanship, you must promptly notify your Dealer; and complete the warranty registration by utilizing the internet at <http://dealer.highwayequipment.com> for such Product before the expiration of the warranty period (Genuine Parts do not require a warranty registration but may require proof of purchase). If your Dealer determines that the defect is due to Highway's material or workmanship, your Dealer will, with Highway's consent, repair such defect during normal working hours, at their location, or such other location as the Dealer may designate. The installation of any part that did not originate from Highway will void this Basic Warranty in its entirety. In the event of repair or replacement, the warranty period shall not be extended beyond the original warranty period. In the case of a demonstration or rental machine (Demo), the warranty will begin at the date of delivery to the original user. If the Demo is sold within the first 120 days of the demo or rental period, the warranty will re-start to the date it is delivered to the end user. If the Demo is sold after the 120th day, the warranty will remain at the date of original delivery to the original user.

EXTENDED WARRANTY

In lieu of the basic warranty described above, if the warranty registration (or warranty information as provided above) is received at Highway within thirty (30) days after the date of delivery to the original user, Highway will warrant that the Product will, under normal conditions of use and service, be free from material defects due to faulty manufacturing for a period of thirteen (13) months from the date of delivery to the original user. For any Product that does not conform to the aforesaid warranty within thirteen (13) months from the date of delivery, your Dealer will, at its option, send you a new part, or give you full credit for the part, provided the replacement part is purchased through your Dealer. Labor costs for this extended warranty coverage will be paid by Highway to the Dealer at their standard shop rate, based on the amount of time Highway establishes to be the time reasonably necessary to make required repairs. If the Product is defective in materials or workmanship, you must promptly notify your Dealer before the expiration of the warranty period. If your Dealer determines that the defect is due to Highway's material or workmanship, your Dealer will, with Highway's consent, repair such defect during normal working hours, at their location, or such other location as your Dealer may designate. In the event of repair or replacement, the warranty period shall not be extended beyond the original warranty period. In the case of a Demo, the warranty will begin at the date of delivery to the original user provided the machine is registered with Highway within 30 days. If the Demo is sold within the first 120 days of the demo or rental period and the machine is registered with Highway within 30 days of the sale, the extended warranty will re-start to the date it is delivered to the end user. If the Demo is sold after the 120th day and is registered with Highway within 30 days of the sale, the extended warranty will remain at the date of original delivery to the original user.

Genuine Parts are covered by the Basic Warranty and are not eligible for the Extended Warranty.

If you fail to complete the warranty registration (or warranty information as provided above) to Highway within thirty (30) days after the date of delivery, this extended warranty shall not apply, and your sole remedy for any defects in the Product shall be under the basic warranty described above. This includes all demo or rental machines.

The above warranties do not cover:

- (1) Product that is damaged by abuse, neglect, accident, or modification;
- (2) fluids, towing, telephone, travel and cleaning cost;
- (3) loss of use of vehicle, inconvenience, commercial loss, or consequential damages;
- (4) any combustion engine; or
- (5) the Product itself if parts are installed on the Product that did not originate from Highway.
- (6) Labor for Genuine Parts.

The above warranties do not apply under the following conditions:

- (1) when Product has been improperly used or installed, or modified, or fitted with sideboards, or fails because of defects or inefficiency of components not furnished with the Product;
- (2) **when Product is used for purposes for which it was not originally designed or intended;**
- (3) when Product is used under abnormal operating conditions; or
- (4) when the dealer or user fails to follow Highway instructions regarding the Product, including the instruction to install only Highway-supplied parts onto the Product.

HIGHWAY WILL BEAR NO OTHER EXPENSE, INCLUDING BUT NOT LIMITED TO LABOR AND MATERIAL COSTS (OTHER THAN THOSE SPECIFIED HEREIN) OF ANY KIND, AND YOUR EXCLUSIVE REMEDY, IN LIEU OF ALL INCIDENTAL, SPECIAL, CONSEQUENTIAL OR ANY OTHER DAMAGES, INCLUDING, BUT NOT LIMITED TO, DAMAGES FOR NEGLIGENCE, IS LIMITED TO REPAIR OR REPLACEMENT AS HERETOFORE DESCRIBED. THE FOREGOING WARRANTIES ARE IN LIEU OF ALL OTHER REPRESENTATIONS OR WARRANTIES, EXPRESS OR IMPLIED OF ANY KIND REGARDING ANY PRODUCT, INCLUDING BUT NOT LIMITED TO THE IMPLIED WARRANTIES OF MERCHANTABILITY AND FITNESS FOR A PARTICULAR PURPOSE OR USE. IN NO CASE SHALL HIGHWAY BE LIABLE FOR ANY SPECIAL, INCIDENTAL OR CONSEQUENTIAL DAMAGES BASED UPON BREACH OF WARRANTY, BREACH OF CONTRACT, NEGLIGENCE, STRICT TORT, OR ANY OTHER LEGAL THEORY.

Unless modified in writing, signed by both parties, this Limited Warranty is understood to be the complete and exclusive agreement between the parties, superseding all prior agreements, oral or written, and all other communications between the parties relating to the subject matter of this Limited Warranty. No representative or agent of Highway nor any third party has authority to change or modify this warranty in any respect, nor to assume any other obligation or liability on behalf of Highway. Any action for breach of warranty must be commenced within six (6) months following the expiration of the Limited Warranty.

These warranties are extended only to the original Dealer and are not transferable. In the event of a warranty claim, you should promptly notify your Dealer, and provide the following:

1. Model and serial number of the Product;
2. Date of delivery to the original user;
3. Part number of the defective part;
4. Description of the difficulty encountered;
5. Date of repair.

Highway will work with your Dealer regarding instructions for repair, replacement, or refund, if the warranty claim can be validated.

Effective with Product delivered to original user on or after August 25, 2014.

SAFETY

PLEASE ! ALWAYS THINK SAFETY FIRST !!

The purpose of this manual is to familiarize the person (or persons) using this unit with the information necessary to properly install, operate, and maintain this system. The safety instructions indicated by the safety alert symbol in the following pages supersede the general safety rules. These instructions cannot replace the following: the fundamental knowledge that must be possessed by the installer or operator, the knowledge of a qualified person, or the clear thinking necessary to install and operate this equipment. Since the life of any machine depends largely upon the care it is given, we require that this manual be read thoroughly and referred to frequently. If for any reason you do not understand the instructions, please call your authorized dealer or our Product Sales and Support Department at 1-888-363-8006.

It has been our experience that by following these installation instructions, and by observing the operation of the spreader, you will have sufficient understanding of the machine enabling you to troubleshoot and correct all normal problems that you may encounter. Again, we urge you to call your authorized dealer or our Product Sales and Support Department if you find the unit is not operating properly, or if you are having trouble with repairs, installation, or removal of this unit.

We urge you to protect your investment by using genuine NLM parts and our authorized dealers for all work other than routine care and adjustments.

New Leader Manufacturing reserves the right to make alterations or modifications to this equipment at any time. The manufacturer shall not be obligated to make such changes to machines already in the field.

This Safety Section should be read thoroughly and referred to frequently.

ACCIDENTS HURT !!!

ACCIDENTS COST !!!

ACCIDENTS CAN BE AVOIDED !!!

Important Safety Information

▲ WARNING

Before using this equipment, read, understand and follow all instructions in the Operator’s Manual provided with this equipment. If the user and/or assistants cannot read or understand the warnings and instructions, the employer of the user and/or assistants must provide adequate and necessary training to ensure proper operation and compliance with all safety procedures pertaining to this equipment. If Operator’s Manual has been lost, visit www.newleader.com or call your authorized dealer or our Product Sales & Support Department at (800) 363-1771 for replacements. Serious injury or death can result from the failure to read, understand, and follow instructions provided in this manual.

Figure 1.1 - The need for safety cannot be stressed strongly enough in this manual. At New Leader Manufacturing, we urge you to make safety your top priority when operating any equipment. We firmly advise that anyone allowed to operate this machine carefully read, learn and understand all messages and information in this manual and on machine’s safety decals before operating machine, as well as familiarize themselves with the location and function of all machine controls.

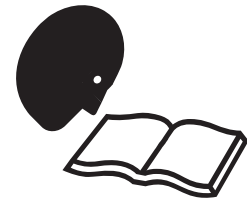

Figure 1.1

The following guidelines are intended to cover general usage and to assist you in avoiding accidents. There will be times when you will run into situations that are not covered in this section. At those times the best standard to use is common sense. If, at any time, you have a question concerning these guidelines, please call your authorized dealer or our Product Sales & Support Department at (800) 363-1771.

Safety Alert Symbols



Take note! This safety alert symbol found throughout this manual is used to call your attention to instructions involving your personal safety and that of others. Failure to follow these instructions can result in injury or death.

In this manual and on the safety signs placed on the unit, the words “DANGER,” “WARNING,” “CAUTION,” and “NOTICE” are used to indicate the following:



DANGER indicates a hazardous situation which, if not avoided, will result in death or serious injury.



WARNING indicates a hazardous situation which, if not avoided, could result in death or serious injury.



CAUTION indicates a hazardous situation which, if not avoided, could result in minor or moderate injury.



NOTICE is used to address practices not related to physical injury.

NOTE:

Provides additional information to simplify a procedure or clarify a process.



General Safety Rules

Operations

PREPARE FOR EMERGENCIES

Figure 1.2 - Be prepared if a fire starts. Keep a fully charged fire extinguisher and first aid kit in accessible place on the vehicle at all times.

Fire extinguisher must be Type ABC or Type BC.

Keep emergency numbers for doctors, ambulance service, hospital and fire department available at all times.



Figure 1.2

INSPECT HARDWARE BEFORE USE

Figure 1.3 - Inspect all bolts, screws, fasteners, keys, chain drives, body mounts and other attachments periodically. Immediately replace any missing or damaged parts with NLM specified parts.

Inspect spinner fins, spinner frame mounting and spinner fin hardware daily. Look for missing or loose fasteners, wear and cracks. Replace immediately with NLM specified parts.

Tighten all bolts, nuts and screws to specified torques. Refer to "Standard Torques" in Maintenance section of this manual.

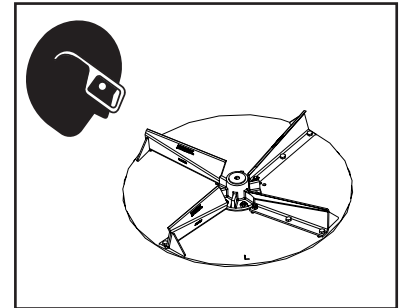

Figure 1.3

HANDLE FLAMMABLE MATERIALS SAFELY

Figure 1.4 - Handle fuel and hydraulic oil with care. They are highly flammable.

Exposure to toxic fluids or fumes may occur during the normal operation of this system. Before attempting to fill, use, or service this system, read Safety Data Sheets (SDS) to know the specific hazards of the fluids you are using. Always use proper Personal Protective Equipment when attempting to fill, use, or service this system.

Always stop engine before refueling machine or filling hydraulic reservoir.

Never smoke while adding fuel or oil to machine. Add fluids in a safe place away from open flame and sparks.

Do not allow overflow. Clean up spilled fuel and oil immediately.

Always have a multipurpose dry chemical fire extinguisher filled and available during machine operation and when adding fuel. Know how to use it.

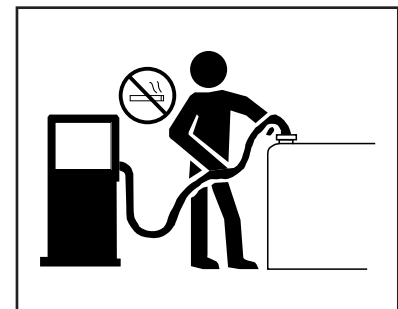

Figure 1.4

General Safety Rules

Operations

HANDLE HAZARDOUS MATERIALS SAFELY

Figure 1.5 - Materials to spread can be dangerous.

Improper selection, application, use or handling may be a hazard to persons, animals, plants, crops or other property.

A Safety Data Sheet (SDS) provides specific details on chemical products: physical and health hazards, safety procedures and emergency response techniques.

Check all SDS's before starting any job using a hazardous material. Follow all instructions and precautions given by the material manufacturer.



Figure 1.5

WORK IN WELL-VENTILATED AREAS

▲ WARNING	Never run machine engine inside a building unless adequate ventilation is provided to safely and properly remove exhaust fumes. Failure to comply with this requirement could result in death or serious injury.
------------------	--

Figure 1.6 - Always work in a properly ventilated area.

Engine exhaust fumes can cause sickness or death. If it is necessary to run an engine in an enclosed area, use proper equipment to safely remove exhaust fumes from the working area.

Open building doors and get fresh air into the working area whenever possible.



Figure 1.6

PROTECT AGAINST NOISE

Figure 1.7 - Long periods of exposure to high decibels or loud noise can cause hearing impairment or loss.

Wear proper hearing protection such as earmuffs or earplugs during periods of exposure to high decibels or loud noise.

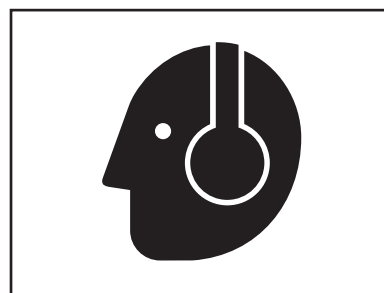

Figure 1.7

General Safety Rules

Operations

AVOID MOVING PART HAZARDS

Figure 1.8 - Entanglement in rotating drive lines or moving parts will cause serious injury or death.

Stay clear of all moving parts, such as shafts, couplings and universal joints.

Make sure all personnel are clear of machine before starting.



Figure 1.8

Figure 1.9 - Do not operate machine without all guards and shields closed and secured.

Disconnect and lock out power source before removing guards.

Disconnect and lock out power source before adjusting or servicing.

Keep hands, feet, hair and clothing away from moving parts.

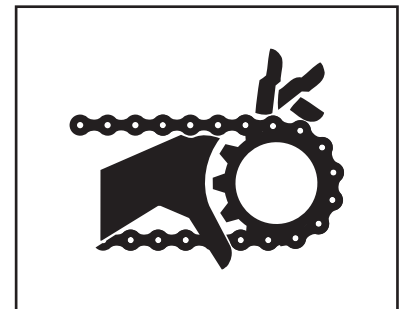

Figure 1.9

Figure 1.10 - Keep away from spinners while they are turning.

Rocks, scrap metal and other material can be thrown from the spinners violently. Stay away from discharge area.

Stop machine before servicing or adjusting. Wear eye protection.

Make sure discharge area is clear before spreading.

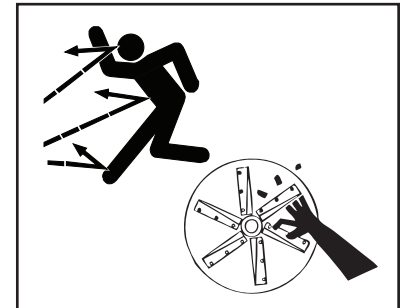

Figure 1.10

Figure 1.11 - Stay out of spreader.

If necessary to enter the spreader, return to shop, empty body, turn off all power, engage brakes, shut down engine and remove keys before entering.

Tag all controls to prohibit operation. Tags should be placed, and removed, by the person working in the body.

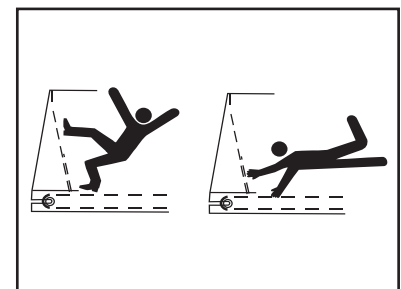

Figure 1.11

General Safety Rules

Operations

DO NOT CLIMB OR STAND ON MACHINE

Figure 1.12 - Never allow any personnel to ride in or on the machine.

Use inspection ladder or portable ladder to view the unit. Use caution when getting on and off the ladder, especially in wet, icy, snowy or muddy conditions. Clean mud, snow and ice from steps and footwear.

Always maintain three-point contact with steps, ladders and handholds. Face the machine when mounting and dismounting inspection ladder. Do not jump off machine.



Figure 1.12

OPERATE MACHINE SAFELY

Always walk around and visually inspect machine before using. Check the immediate vicinity of machine for people and obstructions. Ensure adequate visibility.

Avoid distractions such as reading, eating or operating personal electronics while operating machine. Never operate the machine under the influence of alcohol, drugs or while otherwise impaired.

Always come to a complete stop before reversing. Be sure that all personnel are clear of machine path. Turn around and look directly for best visibility. Ensure all rear view mirrors are properly installed and adjusted. Use a signal person when backing if view is obstructed or when in close quarters.

Always disengage hydraulics before shutting down engine. DO NOT start engine with hydraulics engaged.

General Safety Rules

Transportation & Handling

TRAVELING & TRANSPORTING ON PUBLIC ROADS

Always walk around and visually inspect the machine before traveling on public roads. Check for damage and/or faulty components that can fail and create a hazard or unsafe condition. Make sure all machine systems operate properly, including but not limited to: headlights, tail and brake lights, hazard warning lights, turn indicators, parking brake, horn and rear view mirrors. Repair or replace any component that is not in proper working order.

Never drive machine at a speed that causes it to bounce or cause loss of control.

Obey all traffic safety laws and regulations. Operate the machine with hazard warning lights on, unless prohibited by law. It is the operator's responsibility to activate and use road lights properly while traveling on public roads.

Cover all loads that may spill or blow away. Environmental damage may result. Do not spread dusty materials where dust may create pollution, visibility issues or interfere with traffic on public roads.

When transporting equipment or machine on a trailer, ensure it is properly secured. Be sure that SMV signs on equipment or machine are covered while in transport on a trailer.

Be aware of overhead structures and power lines. Make sure machine can safely pass under. Refer to "Dimensions & Capacities" pages in the Operations section of this manual.

NAVIGATING ROUGH & UNEVEN TERRAIN

Figure 2.1 - Turn slowly and be careful when traveling on rough surfaces and side slopes. Avoid holes, ditches and obstructions that may cause machine to roll over, especially with a loaded spreader.

Never drive near the edge of a gully or steep embankment.

Load may shift, causing vehicle to tip.

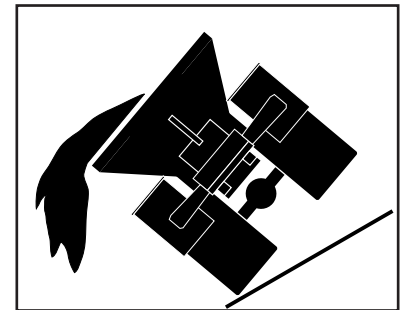

Figure 2.1

General Safety Rules

Maintenance

READ AND UNDERSTAND MAINTENANCE PROCEDURES

Figure 3.1 - Read the maintenance and safety instructions and understand them before performing any maintenance procedure.

Never perform any maintenance procedure or repair if the instructions and safety procedures are not fully understood. Only trained and qualified personnel should perform any maintenance procedure or repair.

Never modify any equipment or add attachments not approved by New Leader Manufacturing.

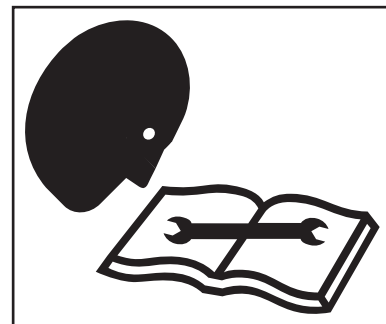

Figure 3.1

DO NOT SERVICE OR ADJUST MACHINE WHILE IN MOTION

Figure 3.2 - Never lubricate, service or adjust the machine or any of its components while they are moving.

Never wear loose clothing or jewelry when working near machine tools or moving parts.

Remove rings and other jewelry to prevent electrical shorts and other personal injury when in contact with machine tools or moving parts.

Close and secure all guards removed for service. Check all screws, bolts, nuts and fasteners for proper torques before operating machine.

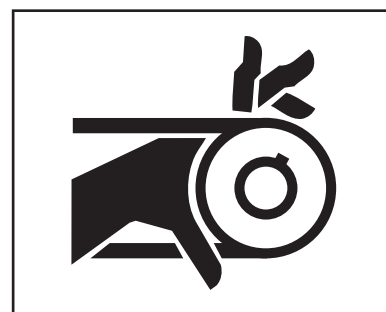

Figure 3.2

WEAR PROPER PROTECTIVE EQUIPMENT

Figure 3.3 - Wear close-fitting clothing and proper safety equipment for the job.

Always wear eye protection when working on or around the machine.

Wear a suitable hearing protection device such as earmuffs or earplugs to protect against high decibels or loud noises.

Prolonged exposure to high decibels or loud noise can cause hearing impairment or loss of hearing.

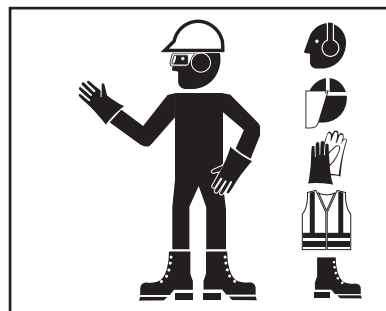

Figure 3.3

Wear protective gloves to protect hands from cuts, abrasions and minor burns.

General Safety Rules

Maintenance

HANDLE FLAMMABLE SOLVENTS SAFELY

Figure 3.4 - Never use diesel fuel, kerosene, gasoline or any flammable solvents for cleaning.

Exposure to toxic fluids or fumes may occur during the normal operation of this system. Before attempting to fill, use, or service this system, read Safety Data Sheets (SDS) to know the specific hazards of the fluids you are using. Always use proper Personal Protective Equipment when attempting to fill, use, or service this system.

Perform work using flammable fluids and solvents in a safe place away from open flame and sparks. Do not smoke.

Do not weld, grind or flame cut on any tank containing oil, fuel, fumes or any other flammable material, or any container that contents or previous contents are unknown. Move all flammable materials and containers away from work area.

Clean up spilled fuel and oil immediately.

Always have a multipurpose dry chemical fire extinguisher filled and available. Know how to use it.



Figure 3.4

USE PROPER LIFTING EQUIPMENT

Figure 3.5 - Use only lifting devices that meet or exceed OSHA standard 1910.184 or ASME B30.20-2013.

Never lift equipment over people.

Never lift a loaded unit. Never lift unit with any loose objects or persons in the body. Loads may shift or fall if improperly supported, causing death, serious injury or machine damage.

Before unfastening heavy parts or assemblies, support with adequate hoist or other device to prevent falling, tipping, swinging or any other movement that may cause injury or damage.



Figure 3.5

USE PROPER TOOLS FOR THE JOB

Figure 3.6 - Use of improper tools (such as a screwdriver instead of a pry bar, pliers instead of a wrench, a wrench instead of a hammer) can cause serious injuries or machine damage.

Use power tools only to loosen threaded parts and fasteners. Using power tools to tighten may cause over-tightening and component damage.

Use only service parts meeting New Leader specifications.

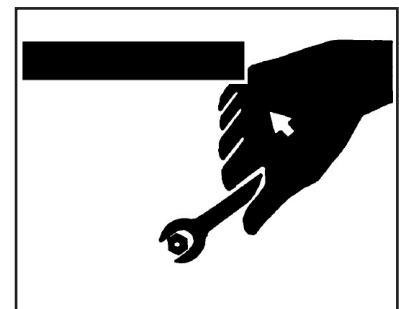

Figure 3.6



General Safety Rules

Maintenance

HIGH PRESSURE FLUID HAZARDS

Figure 3.7 - Escaping fluid under pressure can penetrate the skin causing serious injury.

Always stop machine, allow to cool and relieve pressure before servicing hydraulic system. Never open hydraulic lines under pressure. Make sure all connections are tight and all hoses are in good condition before pressurizing system.

Always use a piece of cardboard or wood to search for leaks instead of hand. Wear impervious gloves and eye protection when servicing system.

Seek medical attention immediately if fluid penetrates your skin. Gangrene may result if wound is left untreated.



Figure 3.7

AVOID HEATING NEAR HIGH PRESSURE FLUID LINES

Figure 3.8 - Flammable spray can be generated by heating near pressurized fluid lines, resulting in burns to yourself and bystanders.

Do not heat by welding, soldering or using a torch near pressurized fluid lines or other flammable materials.

Pressure lines can suddenly burst when heat goes beyond the immediate flame area.

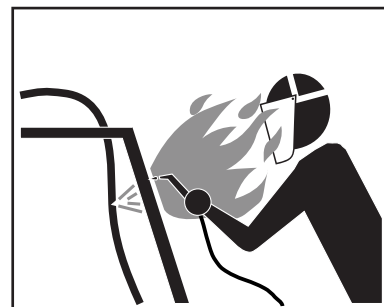

Figure 3.8

AVOID TOXIC FUMES & DUST

Figure 3.9 - Hazardous fumes can be generated when paint is heated from welding, soldering or using a torch.

Remove paint before heating:

- Remove a minimum of 4 in (100 mm) from area to be affected by heating. If paint cannot be removed, wear an approved respirator while heating or welding.
- Avoid breathing dust from sanding or grinding on paint.
- If a solvent or paint stripper is used, wash stripper away with soap and water before heating or welding. Remove solvent or paint stripper containers and other flammable material from area. Allow fumes to disperse for at least 15 minutes before heating or welding.

Do not use chlorinated solvents in areas where welding will take place.

Perform all work in a well-ventilated area that will carry all toxic fumes and dust away.



Figure 3.9

General Safety Rules

Maintenance

CLEAN MACHINE OF HAZARDOUS CHEMICALS

CAUTION

During application of hazardous chemicals, residue can build up on the inside or outside of the vehicle. Clean vehicle according to use instructions of hazardous chemical. Failure to comply with this requirement may result in minor or moderate injury.

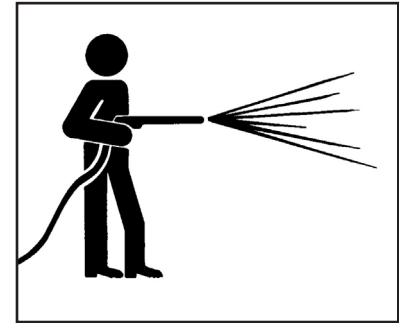

Figure 3.10

Figure 3.10 - When exposed to hazardous chemicals, clean exterior and interior of vehicle daily to keep free of the accumulation of visible dirt and contamination.

1. Clean operator's station to maintain unobstructed visibility of all windows and mirrors, and safe operation of all controls.

NOTICE

Directing pressurized water at electronic/ electrical components, bearings and hydraulic seals or other sensitive parts and components may cause product malfunctions. Reduce pressure and spray at 45 to 90 degree angles.

2. Wash entire exterior of vehicle.
3. Dispose of any wash water with hazardous concentrations of active or non-active ingredients according to published regulations or directives.

HANDLE BATTERIES SAFELY

WARNING

Sulfuric acid in battery electrolyte is poisonous. It can burn skin, eat holes in clothing, and cause blindness if it contacts eyes. Keep sparks and flame away from batteries. Wear proper safety equipment. Failure to comply with this requirement could result in death or serious injury.

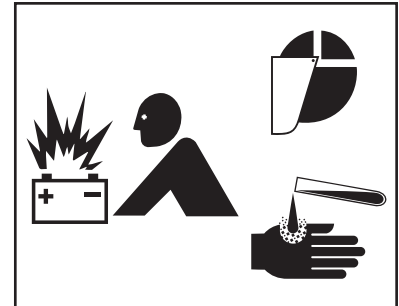

Figure 3.11

Figure 3.11 - Lead acid batteries generate flammable and explosive gases. Keep sparks and flame away from batteries. Do not smoke.

If acid contacts eyes, skin or clothing, flush with water immediately. Seek immediate medical attention if acid contacts eyes.

PROPER TIRE MAINTENANCE

Figure 3.12 - Never weld on a wheel or rim that has a tire on it.

Never attempt to mount or remove a tire unless using the proper equipment, tire safety cage, instructions, training, and you are qualified to perform the work safely. Failure to follow the correct procedures when mounting a tire on a wheel or rim can cause an explosion and serious injury.

Tire service procedures must be performed by trained and qualified personnel.



Figure 3.12

General Safety Rules

Storage

PARK VEHICLE SAFELY

Figure 4.1 - When leaving the vehicle unattended for any reason, be sure to:

- Shut down PTO.
- Shut off vehicle's engine, and unit's engine if applicable.
- Place vehicle transmission in "Neutral" or "Park".
- Set parking brake firmly.
- Remove ignition key and take it with you.
- Block wheels.

These actions are recommended to avoid unauthorized use, runaway, vandalism, theft and unexpected operation during startup.

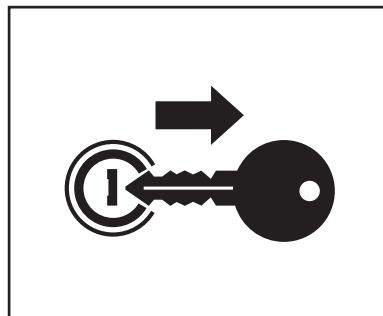

Figure 4.1

SUPPORT MACHINE PROPERLY

Figure 4.2 - When machine is removed from vehicle, always store on adequate supports on a firm level surface. Improper supporting or storage of spreader may cause machine to fall, resulting in serious injury or death.

Never use lifting device to free machine from a chassis, storage stands or frozen ground, or to lift the chassis in any way. Shock loading is prohibited and sudden accelerations must be avoided. Lifting in such a manner could result in injury or machine damage.



Figure 4.2

DISPOSE OF WASTE PROPERLY

Figure 4.3 - Improper disposal of waste can threaten the environment and ecology. Potentially harmful waste used with equipment include items such as fuel, oil, filters and batteries.

Use leakproof containers when draining fluids. Do not use food or beverage containers that may mislead someone into drinking from them. Do not pour waste onto the ground, down a drain, or into any water source.

Comply with all OSHA, local, City, State, Province, Country and jurisdiction regulations, ordinances and standards, related to your particular work area and environment. Inquire on proper disposal methods from your local environmental or recycling center, or from your local dealer.

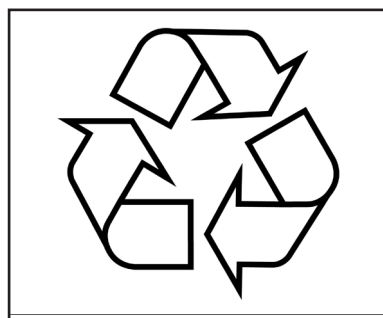

Figure 4.3

Safety Decal Maintenance

Keep safety decals and signs clean and legible at all times.

Replace safety decals and signs that are missing or have become illegible.

Replaced parts that displayed a safety sign should also display the current sign.

Safety decals or signs are available from your dealer's Parts Department or from New Leader Manufacturing by calling (800) 363-1771.

Safety Decal Installation

Clean Surface

Wash the installation surface with a synthetic, free-rinsing detergent. Avoid washing the surface with a soap containing creams or lotion. Allow to dry.

Position Safety Decal

Decide on the exact position before application. Application marks may be made on the top or side edge of the substrate with a lead pencil, marking pen, or small pieces of masking tape. NOTE: Do not use chalk line, china marker, or grease pencil. Safety decals will not adhere to these.

Remove the Liner

A small bend at the corner or edge will cause the liner to separate from the decal. Pull the liner away in a continuous motion at a 180-degree angle. If the liner is scored, bend at score and remove.

Apply Safety Decal

Tack decal in place with thumb pressure in upper corners. Using firm initial squeegee pressure, begin at the center of the decal and work outward in all directions with overlapping strokes. NOTE: Keep squeegee blade even—nicked edges will leave application bubbles. Pull up tack points before squeegeeing over them to avoid wrinkles.

Remove Pre-mask

If safety decal has a pre-mask cover remove it at this time by pulling it away from the decal at a 180 degree angle. NOTE: It is important that the pre-mask covering is removed before the decal is exposed to sunlight to avoid the pre-mask from permanently adhering to the decal.

Remove Air Pockets

Inspect the decal in the flat areas for bubbles. To eliminate the bubbles, puncture the decal at one end of the bubble with a pin (never a razor blade) and press out entrapped air with thumb moving toward the puncture.

Re-Squeegee All Edges

Safety Decals

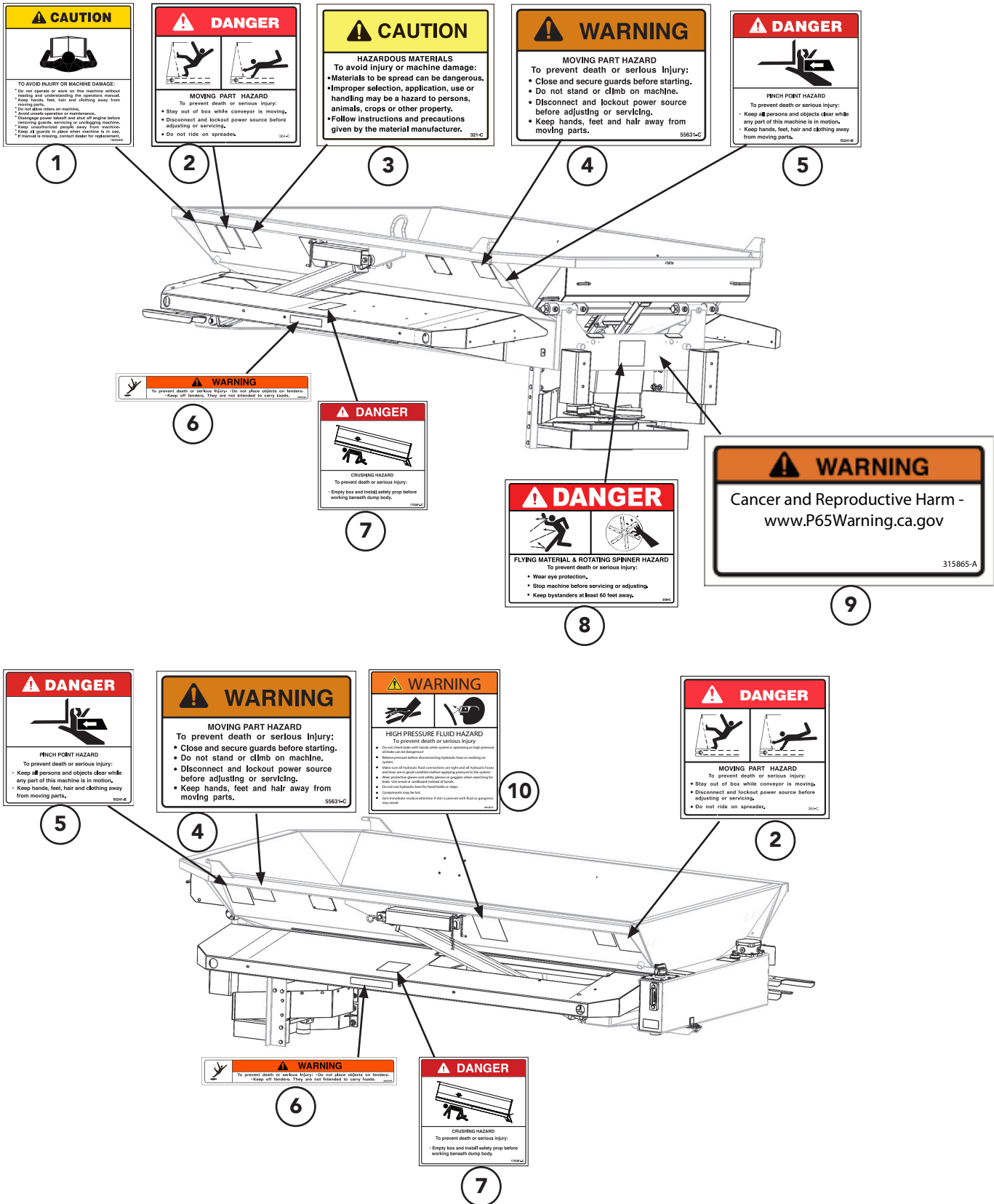

1. CAUTION: TO AVOID INJURY OR MACHINE DAMAGE:**To avoid injury or machine damage:**

- Do not operate or work on this machine without reading and understanding the operator's manual.
- Keep hands, feet, hair and clothing away from moving parts.
- Do not allow riders on machine.
- Avoid unsafe operation or maintenance.
- Disengage power takeoff and shut off engine before removing guards, servicing or unclogging machine.
- Keep unauthorized people away from machine.
- Keep all guards in place when machine is in use.
- If manual is missing, contact dealer for replacement.

2. DANGER: MOVING PART HAZARD**To prevent death or serious injury:**

- Stay out of box while conveyor is moving.
- Disconnect and lockout power source before adjusting or servicing.
- Do not ride on the spreader.

3. CAUTION: HAZARDOUS MATERIALS**To avoid injury or machine damage:**

- Materials to be spread can be dangerous.
- Improper selection, application, use or handling may be a hazard to persons, animals, crops or other property.
- Follow instructions and precautions given by the material manufacturer.

4. WARNING: MOVING PART HAZARD**To prevent death or serious injury:**

- Close and secure guards before starting.
- Do not stand or climb on machine.
- Disconnect and lockout power source before adjusting or servicing.
- Keep hands, feet and hair away from moving parts.

5. DANGER: PINCH POINT HAZARD**To prevent death or serious injury:**

- Keep all persons and objects clear while any part of this machine is in motion.
- Keep hands, feet, hair and clothing away from moving parts.

6. WARNING: FALLING HAZARD**To prevent death or serious injury:**

- Do not place objects on fenders.
- Keep off fenders. They are not intended to carry loads.

7. DANGER: CRUSHING HAZARD**To prevent death or serious injury:**

- Empty box and install safety prop before working beneath dump body.

8. DANGER: FLYING MATERIAL AND ROTATING SPINNER HAZARD**To prevent death or serious injury:**

- Wear eye protection.
- Stop machine before servicing or adjusting.
- Keep bystanders at least 60 feet away.

9. WARNING: HAZARDOUS MATERIALS**To avoid injury:**

- Cancer and Reproductive Harm - www.P65Warning.ca.gov

10. WARNING: HIGH-PRESSURE FLUID HAZARD**To prevent death or serious injury:**

- Do not check leaks with hands while system is operating as high pressure oil leaks can be dangerous!
- Relieve pressure before disconnecting hydraulic lines or working on system.
- Make sure all hydraulic fluid connections are tight and all hydraulic hoses and lines are in good condition before applying pressure to the system.
- Wear protective gloves and safety glasses or goggles when searching for leaks. Use wood or cardboard instead of hands.
- Do not use hydraulic lines for hand holds or steps.
- Components may be hot.
- Get immediate medical attention if skin is pierced with fluid as gangrene may result.

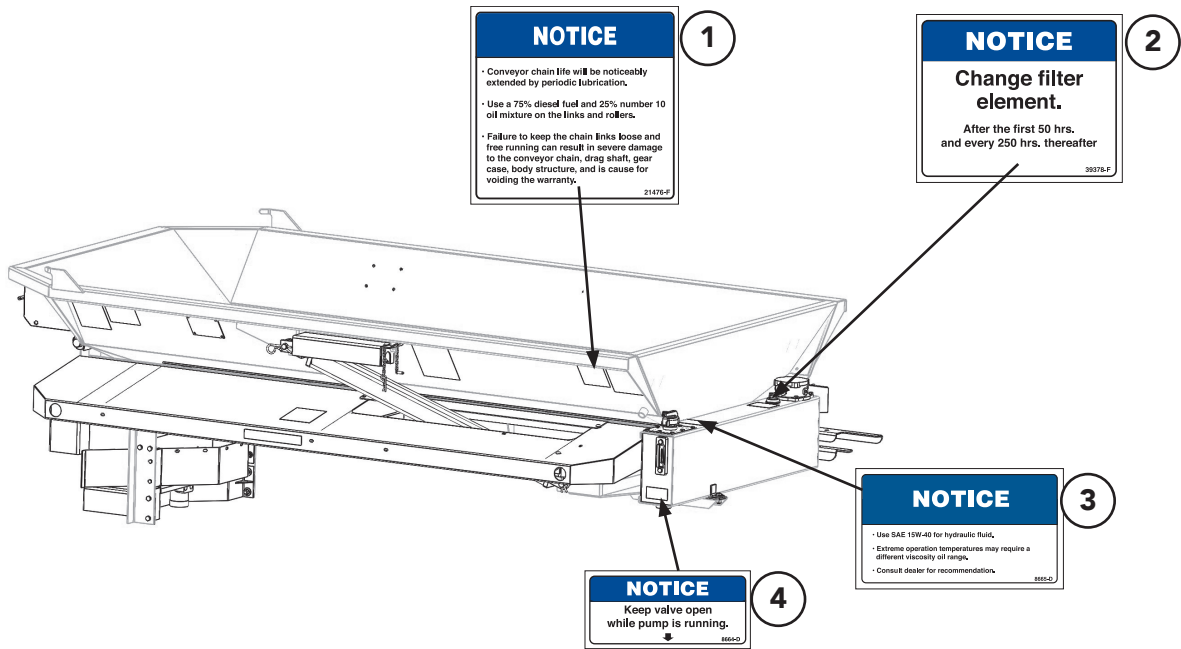

1. NOTICE: CONVEYOR CHAIN LUBRICATION

To avoid machine damage and premature wear:

- Conveyor chain life will be noticeably extended by periodic lubrication.
- Use a 75% diesel fuel and 25% number 10 oil mixture on the links and rollers.
- Failure to keep the chain links loose and free running can result in severe damage to the conveyor chain, drag shaft, gear case, body structure, and is cause for voiding the warranty.

2. NOTICE: CHANGE FILTER ELEMENT

To avoid machine damage and premature wear:

- After the first 50 hrs. and every 250 hrs. thereafter

3. NOTICE: HYDRAULIC FLUID

To avoid machine damage and premature wear:

- Use SAE 1 SW-40 for hydraulic fluid.
- Extreme operation temperatures may require a different viscosity oil range.
- Consult dealer for recommendation.

4. NOTICE: VALVE OPERATION

To avoid machine damage and premature wear:

- Keep valve open while pump is running.

This page is intentionally left blank.

INSTALLATION

INSTALLATION

Installation Instructions

Unpacking

The E1888 is shipped assembled, except for the following parts, which are packed loose:

Spinner	Cab Shield	Calcium Reservoir
Clump Diverter	Stone Shield	Shovel/Broom Mount
Mouting	Prewet System	Hardware for all loose parts

Unpack and inspect the unit and all loose parts for any damage that might have occurred in shipping. If any is found, or any shortages noted, notify your dealer immediately.

Recommended sequence of installation is as follows:

1. Install Clump Diverter
2. Body Mounting
3. Install Cab Shield
4. Install Calcium Reservoir
5. Install Spinner
6. Install Stone Shields
7. Install Shovel & Broom Mount
8. Install Hydraulic Components
 - a. Pump & Pump Drive
 - b. Cab Controls
 - c. Hydraulics
 - d. Fill hydraulic reservoir and lubricate

NOTICE

Pump and truck requirements must be determined prior to installation of the E1888.

Truck Requirements

In mounting the E1888 spreader on a truck, the following major questions must be considered:

1. Is the CA (Cab to Axle) dimension of the truck correct for the length of the spreader?

The Dimensions and Capacities chart in the operator's manual will assist in matching spreader to truck.

2. Is the truck's GAWR (Gross Axle Weight Rating) and the GVWR (Gross Vehicle Weight Rating) adequate to carry the fully loaded spreader?

Refer to your Hi-Way dealer to find the GAWR and GVWR for most trucks, and how to calculate the weight distribution on each axle and total loaded vehicle weight.

Truck Frame Length

Refer to "Dimensions & Capacities" section in the operator's manual for approximate length from the rear of the cab to the rear end of the frame. Shorten truck frame as necessary, making sure to follow truck manufacturer's specifications so as not to void truck warranty.



Installation Instructions Continued

Lifting the Spreader

▲ WARNING

Use only lifting devices that meet or exceed OSHA standard 1910.84 or ASME B30.20-2006. Never lift equipment over people. Never lift unit with anything or anybody in the body. Loads may shift or fall if improperly supported, causing damage to unit, injury or even death.

▲ CAUTION

Do not use lifting device to free unit from a chassis, storage stands or frozen ground, or to lift the chassis in any way. Shock loading is prohibited and sudden accelerations should be avoided. Lifting in such a manner could result in damage to unit or injury.

Always inspect unit lift points for signs of wear, cracking, corrosion, gouges, alterations, or distortion.

Always use a sling, spreader bar, or lifting bar that attaches to the lifting points with a minimum of 60 degrees from horizontal. It is preferable to use an "H" style lifting bar that keeps the attaching chains in a near vertical orientation as shown in Figure 1. Operators of lifting devices must be qualified and knowledgeable in their use and application.

Position the chassis with adequate room around the unit. Work in an environment that permits clear communication to others nearby. Keep area clear of persons when loads are to be lifted and suspended. Do not allow the lifted load to come in contact with any obstruction.

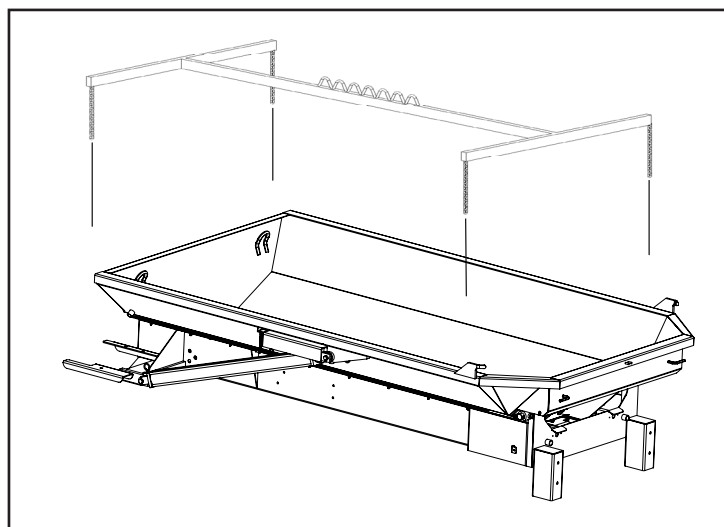

Figure 1 - Lifting Bar

Installation Instructions Continued

Installing Body

Wear Strips

Steel wear strips (not supplied with spreader) 3/8" (1cm) to 1/2" (1.3cm) thick by 3" (7.6cm) wide must be installed on the length of the frame behind the truck cab.

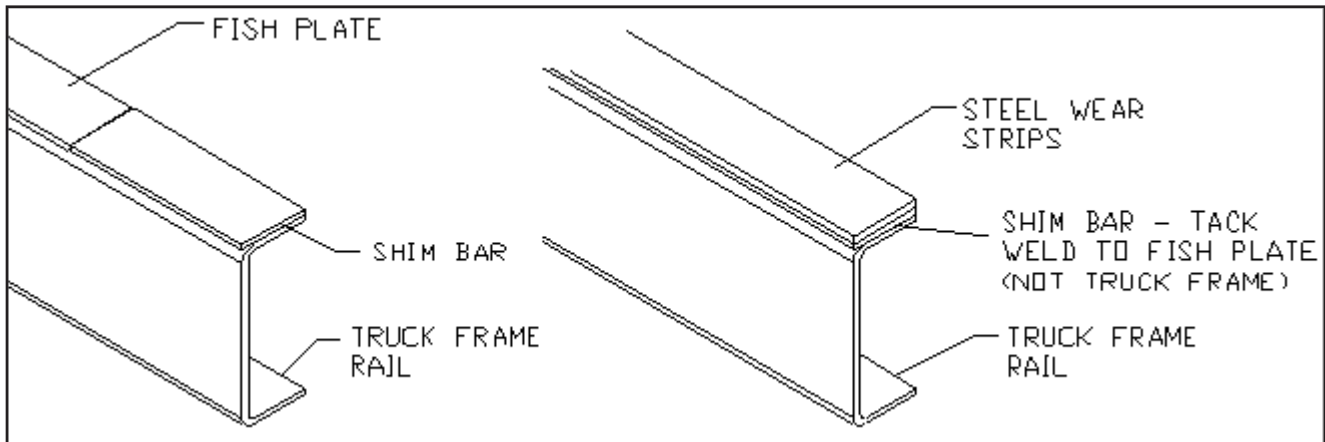

Figure 2 - Steel Wear Strips

Positioning Body

1. If the truck frame has fish plates on the top flange, it will be necessary to provide a level top surface by adding steel shim bars or strips of the same thickness as the fish plates and as wide as the frame channel top flange. These shim bars or strips must be drilled out to clear any rivet or bolt heads and may be tack welded to fishplates. **DO NOT WELD** these bars or strips to the truck frame—to do so may void truck manufacturer's warranty.
2. Cut the wear strip to length and place on top of the truck frame rails.
3. With a heavy hammer, strike directly above each rivet head to mark the position of the rivet.
4. Remove the wear strips and counterbore or drill for the rivet heads.
5. Replace the steel wear strips on the truck frame rails. Tack weld the wear strips to fishplates.
6. Lift empty spreader body onto truck frame. Position E1888 centrally side-to-side and flush with rear of truck. Check position of spreader to make sure the mounting plates can be properly positioned on the truck frame near the front and rear gussets (inside E1888 frame).
7. Tack weld wear strips to sub-frame.



Installation Instructions Continued

NOTICE

DO NOT PUT HOLES INTO TOP OR BOTTOM FLANGES OF TRUCK FRAME—to do so may void truck manufacturer's warranty. When drilling holes in frame member, drill only through vertical web portions.

Installing Mounts

Parts needed:

DESCRIPTION

QTY

Rear Mtg. Plate	2
Rear Mtg. Angle	2
Mtg. Angle- Driver Side	1
Mtg. Angle- Pass. Side	1

NOTE: When installing front and rear mounting plates, a minimum of four inches of the vertical sides of each plate must be in contact with the unit sills.

Position the two front mounting plates with the drilled surfaces against the side of the truck frame.

Mark location of holes on truck frame. Drill 9/16" (1.4cm) diameter holes through truck frame to align with holes in Angles.

CAUTION

When drilling holes, make sure that the drill will not puncture the gas tank or harm any other obstruction!

CAUTION

Make sure spreader is securely anchored and will not shift or slide off of truck body. Periodically check mounting hardware to make sure they are secure. Retighten as required.

Securing Body to Frame

1. Secure mounts to truck frame using 1/2" SAE Grade 8 hardware. Torque to proper spec - refer to "Standard Torques".
2. Weld Mounting Plates and Angles to E1888 subframe on front, top and rear edges.

NOTICE

DO NOT WELD ON THE VEHICLE FRAME. Such welding can lead to fatigue cracking and must be avoided. Do NOT drill through the top or bottom flanges of the truck frame.

NOTICE

If at any time an arc welder is used on the vehicle or anything connected to the vehicle, be sure to disconnect the negative battery cable. Connect the welder's ground directly to one of the two items being welded.



Installation Instructions Continued

Cab Shield Installation

See "Cab Shield" parts list for assembly illustration.

To install cab shield on truck:

1. Position Uprights against truck frame an equal distance from the cab as shown in Figure 3. Make sure there is adequate room for the hydraulic reservoir if it has not been installed.
2. Mark location of holes on truck frame. Remove Uprights and make sure hole locations are aligned and at least 2" from the top and bottom of the rail. Drill 1/2" (13mm) holes where marked.

NOTICE

DO NOT PUT HOLES IN TOP OR BOTTOM FLANGES—to do so may void truck manufacturer's warranty. Drill only through vertical web portions of truck frame, a minimum of 2.00" (5cm) from the top or bottom flanges.

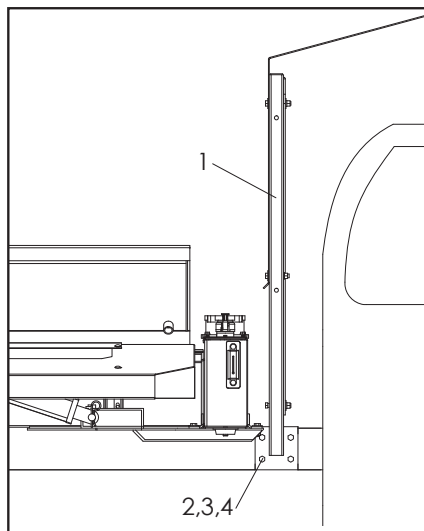

Figure 3 - Cab Shield Installation

3. Attach Uprights using supplied Hardware (2-4).

Parts Needed:

Item	Description	Qty
1	Uprights/Cab Shield	2
2	1/2 x 1-1/2 Cap Screw	8
3	1/2 Lock Washer	8
4	1/2 Hex Nut	8
5	Supports (LH & RH)	2
6	3/8 hardware- dealer supplied	4

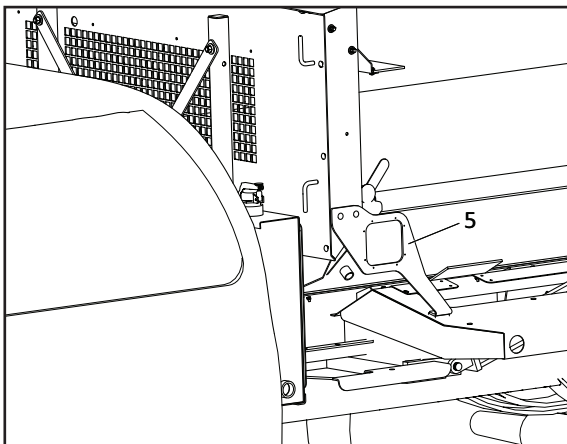

Figure 4 - Cab Shield Support (LH Shown)

4. Attach Supports with 3/8" hardware (dealer supplied).



Installation Instructions Continued

Spinner

Spinner Chute Installation

Parts needed:

<u>DESCRIPTION</u>	<u>QTY</u>
Chute	1
3/8 x 1-1/4 Carriage Bolt	4
3/8 Flat Washer	4
3/8 Lock Washer	4
3/8 Hex Nut	4

1. Place Chute under bottom of E1888 at rear.
2. Align slots on Chute with rearmost square holes on sills and attach using 3/8" hardware provided.

NOTE: The truck's rear cross members may need to be moved to make room for the spinner chute weldment.

Spinner Assembly

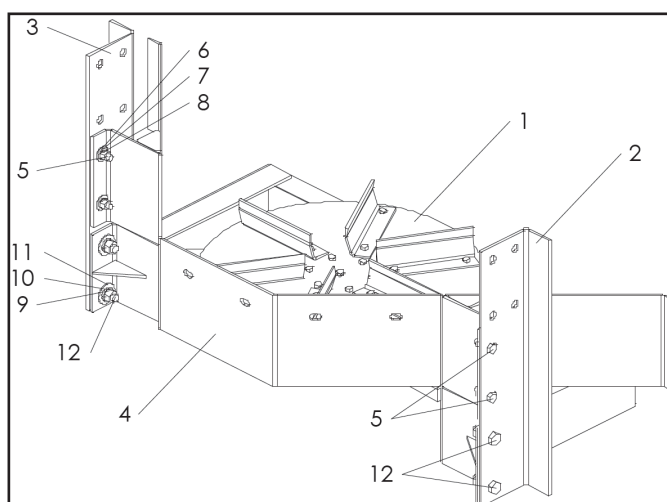

Figure 5 - Spinner Assembly

Parts Needed:

<u>Item</u>	<u>Description</u>	<u>Qty</u>
1	Spinner Assembly	1
2	Spinner Support, LH	1
3	Spinner Support, RH	1
4	Spinner Shield	1
5	3/8 x 1-1/4 Cap Screw	4
6	3/8 Flat Washer	4
7	3/8 Lock Washer	4
8	3/8 Hex Nut	4
9	1/2 Hex Nut	4
10	1/2 Lock Washer	4
11	1/2 Flat Washer	4
12	1/2 x 1-1/2 Cap Screw	4

1. Position Right-Hand (2) and Left-Hand Spinner Supports (3) as shown in Figure 5 and attach to Spinner Assembly (1) using 1/2" Hardware (9–12) finger-tight only.
2. Place Spinner Shield (4) between Supports as shown and attach using 3/8" Hardware (5–8). Do not tighten hardware at this time.

NOTE: Left-hand (LH) and right-hand (RH) descriptions are as viewed from the rear.

Installation Instructions Continued

Spinner Installation

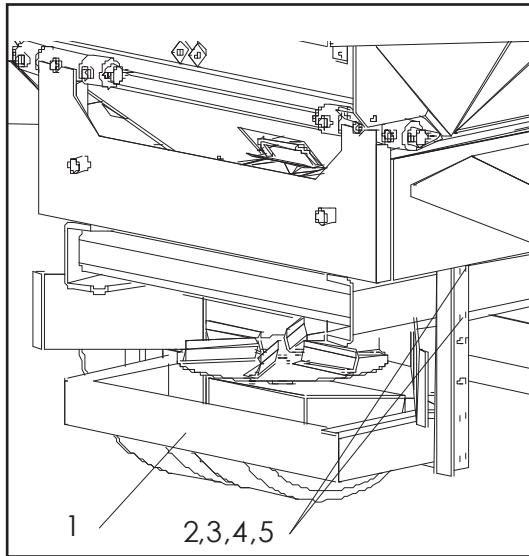

Figure 6 - Spinner Installation

Parts Needed:

Item	Description	Qty
1	Spinner Assembly	1
2	1/2 x 1-1/2 Cap Screw	8
3	1/2 Flat Washer	8
4	1/2 Lock Washer	8
5	1/2 Hex Nut	8

1. Position Spinner Assembly (1) under bottom at rear of unit with supports touching bottom of E1888 frame as shown in Figure 6 (approximately 9.75" from rear of unit).
2. Mark eight hole locations (four on each support) on truck frame.
3. Remove spinner assembly and drill 1/2" holes where marked.
4. Attach spinner assembly to truck frame using Hardware provided (2-5).
5. Tighten all Spinner Hardware per Torque Chart.

Installation Instructions Continued

Hydraulic Hose

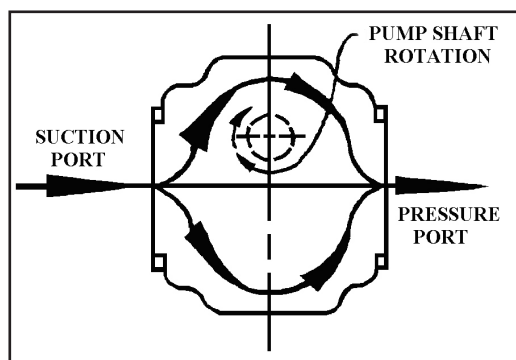

Figure 7 - Hydraulic Pump Installation

Determine pressure port of pump (Figure 7). Install pressure hose into this port. Connect suction hose to opposite port and to tank outlet on reservoir. Use plastic tie straps to support hoses as necessary so they will not catch on field obstructions or contact the muffler or any moving parts.

CAUTION

If a threaded connection is tightened too tightly, the fitting or housing into which the fitting is placed could be distorted and an unstoppable leak could occur.

Use thread sealer on all fittings, except O-ring and JIC adapters, O-ring valves and motors, etc. When using thread sealer, do not put it on the first three threads of the fitting. Too much on the fitting or on the first three threads will force it into the oil stream where it could damage the system.

Place the hose clamps as needed to keep hoses away from hot or moving parts. Do not let hoses hang so low as to be snagged. Do not stretch hoses tight.

Installation Instructions Continued

Installation Guide

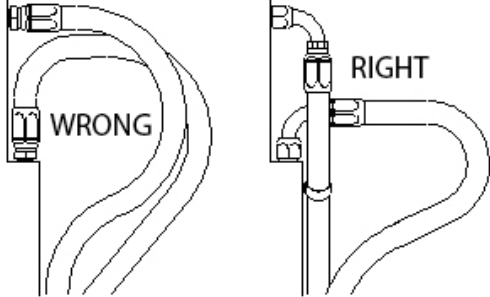
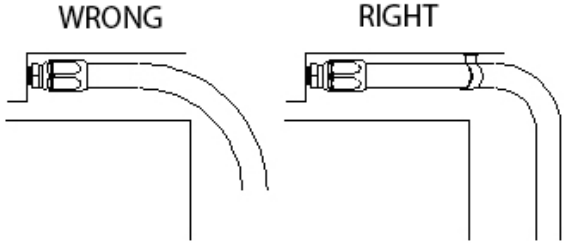
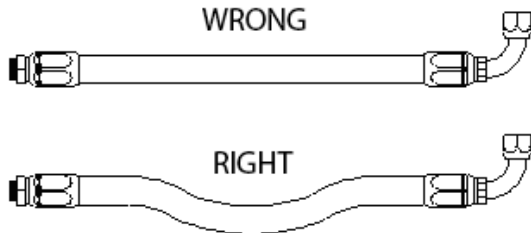
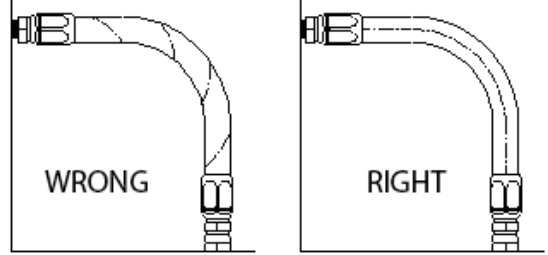
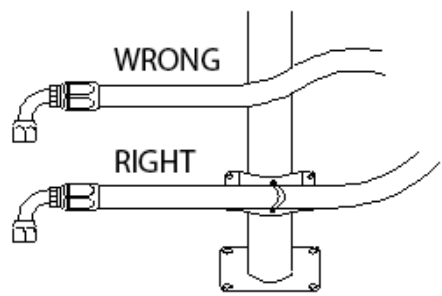
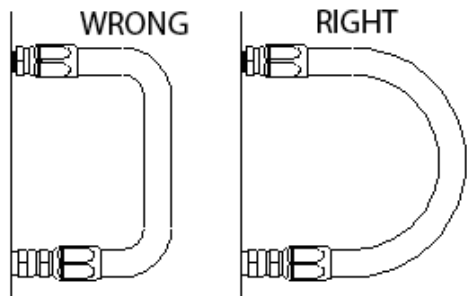
 <p>1. Use elbows and adapters in the installation to relieve strain on the assembly, and to provide easier and neater installations that are accessible for inspection and maintenance. Remember that metal end fittings cannot be considered as part of the flexible portion of the assembly.</p>	 <p>2. Install hose runs to avoid rubbing or abrasion. Clamps are often needed to support long runs of hose or to keep hose away from moving parts. It is important that the clamps be of the correct size. A clamp that is too large will allow the hose to move in the clamp causing abrasion at this point.</p>
 <p>3. In straight hose installations allow enough slack in the hose line to provide for changes in length that will occur when pressure is applied. This change in length can be from +2% to -4%.</p>	 <p>4. Do not twist hose during installation. This can be determined by the printed layline on the hose. Pressure applied to a twisted hose can cause hose failure or loosening of the connections.</p>
 <p>5. Keep hose away from hot parts. High ambient temperature will shorten hose life. If you cannot route it away from the heat source, insulate it.</p>	 <p>6. Keep the bend radii of the hose as large as possible to avoid hose collapsing and restriction of flow. Follow catalog specs on minimum bend radii.</p>

(Used with the permission of The Weatherhead Company.)

Installation Instructions Continued

Electrical Connections

Connect any electrical control circuits. The supply conductor should be connected to the accessory terminal of the truck ignition switch through a five amp line fuse. All wiring should be approved automotive insulated wire. It should be supported adequately with insulating ties or straps and be located where it won't interfere with any control or access, does not contact any moving parts or sharp edges and is kept away from any hydraulic lines or heated parts.

Lights

Light installation must comply with all applicable requirements prescribed by FMVSS/CMVSS 108, state and local regulations.

Filling the Hydraulic System

NOTICE Do not attempt to run pump without first filling hydraulic reservoir with oil and opening suction line gate valve or the pump may be ruined.

Fill reservoir with hydraulic oil as specified in "Lubricant and Hydraulic Oil Specifications". Be sure oil is clean, free from dirt, water, and other contaminants.

Lubricate all points requiring lubrication per the Lubrication Chart.

Checking Installation

See "Initial Start-Up" for detailed procedure.

OPERATIONS

OPERATIONS

General Description

The E1888 is a multi-purpose spreader/dump body with a struck capacity of 54 cubic feet (2 cu. yd). It is intended for mounting on a medium-duty truck chassis.

The low profile body provides a low load-in height. A dumping angle of 65 degrees is sufficient height to dump over the rear endgate.

A 12-1/2" (317mm) chain conveyor runs the entire bottom length of the hopper. It consists of parallel strands of pintle chain joined by cross bars every third link. Material is delivered to the rear hopper-type spinner through an adjustable metering gate. The spinner assembly features a single 18" (457mm) disc with six heat-treated fins.

This product is intended for commercial use only.

Dimensions & Capacities

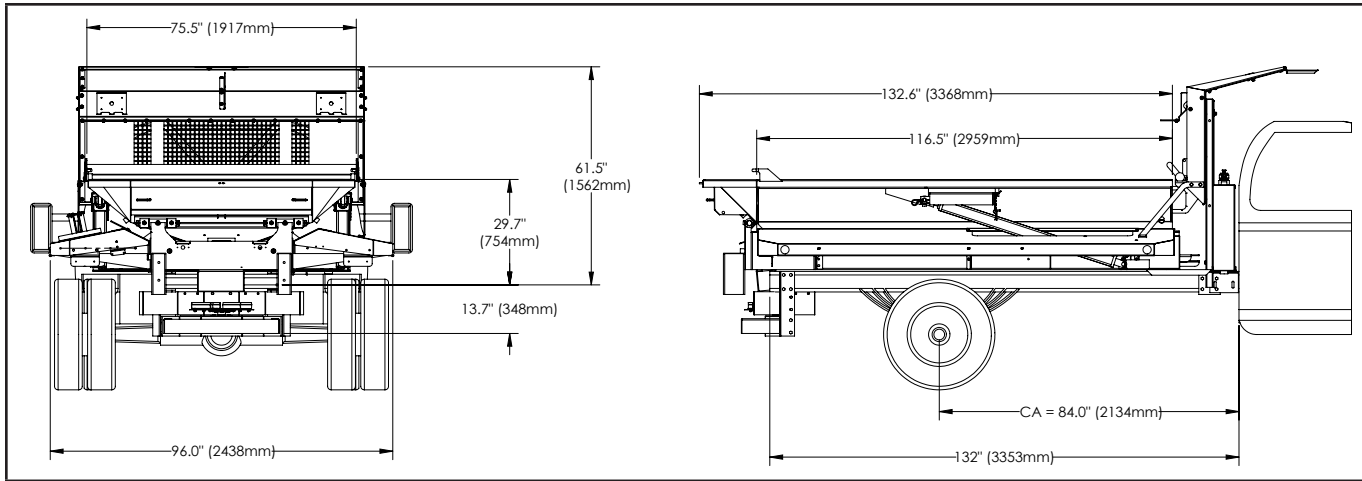

Overall Length in (mm)	Overall Width in (mm)	Frame Length in (mm)	Cab to Axle (CA) in (mm)	Empty Weight lbs (kg)	Struck Capacity cu ft (cu m)
133.5 (3391)	96 (2438)	131.5 (3340)	84 (2133)	500 (226.8)	54 (1.53)

Initial Start-Up

Check over entire unit to be sure all fasteners are in place and properly tightened per Torque Chart in this manual. Disengage PTO driving pump. Be sure On-Off control is in the Off position.

NOTE: Do not load spreader with material.

1. Check to ensure that no loose parts are in the body, on the conveyor or on the spinner. Be sure to remove any loose pieces.
2. Open the feedgate until it is completely clear of the conveyor.
3. Fill the hydraulic reservoir with oil. Refer to "Lubricant & Hydraulic Oil Specifications" for proper oil.
4. If crankshaft PTO transmission has been installed, be sure transmission has proper amount of lubricant.
5. Start the truck engine and set throttle so engine runs at approximately 1000 RPM. Engage PTO. Allow oil to circulate for several minutes. In cold weather, increase warm-up time.
6. Run the spinner. Allow to run until all air is purged from the hydraulic system and the spinner is running smoothly. Turn the spinner control knob to the Off position.
7. Allow conveyor to run until all air is purged from the system it is operating smoothly.
8. Allow both the spinner and conveyor to run to ensure smooth operation. Shut the system down.

CAUTION

Do not use one manufacturer's hose with another manufacturer's fittings! Such use will void any warranty and may cause premature burst or leak of hydraulic fluids. Such bursting or leaking may cause severe injury and/or fire.

9. Check all connections in the hydraulic system to make sure that there are no leaks.

DANGER

Do not check leaks with hands while system is operating. High pressure leaks can be dangerous! If skin is pierced with hydraulic fluid at high pressure seek immediate medical attention as fluid injected into the skin can cause gangrene if left untreated. Relieve system pressure before disconnecting hydraulic lines or working with system. Make sure all hydraulic fluid connections are tight and all hydraulic hoses and lines are in good condition before applying pressure to the system. Wear protective gloves and safety glasses or goggles when working with hydraulic systems.

WARNING

DO NOT check for hydraulic leaks adjacent to moving parts while system is operating as there may be danger of entanglement!

10. Check hydraulic oil reservoir and refill as necessary. Unit is now ready for road testing.



General Operating Procedures

Before taking unit out to use, make a walk-around inspection to assure that spreader is not damaged, that all essential parts in place and that all fasteners are tight and all guards are in place. Check all controls for proper operation.

If the unit is to be used for garbage pick-up, make sure the conveyor cover is in place. The cover is to be placed flat in the bottom of the spreader hopper with the handle facing upward, near the feedgate. Before using the unit for spreading, remove the conveyor cover by opening the feedgate and lifting out with the handle.

If material to be spread is not already in spreader, partially load the unit. With On-Off control in Off position, engage pump drive and allow oil to circulate until it is warm. This may be done while traveling to loading or starting point. The colder the weather, the more critical hydraulic oil warm-up becomes.

All spinner speed adjustments must be made with spinner and conveyor turned Off to avoid injury from spinner and/or discharging material.

Adjust spinner speed to obtain spread width desired. In addition to spinner speed, spread width is affected by material granular size, density and moisture content. Proper spinner speed is obtained by trial and experience.

Spinner speed selected should be the lowest required to obtain the desired spread width with the material being spread. High spinner speeds create uncontrolled throw and bounce of materials, and may result in damage to vehicles or pedestrian injury.

NOTE: Close the feedgate before loading the spreader and when traveling to the location where spreading is to be done. Open feedgate before starting to spread.

NOTE: Disengage PTO when spreader is not in use for long periods of time or when moving to and from job site after initial warm-up.

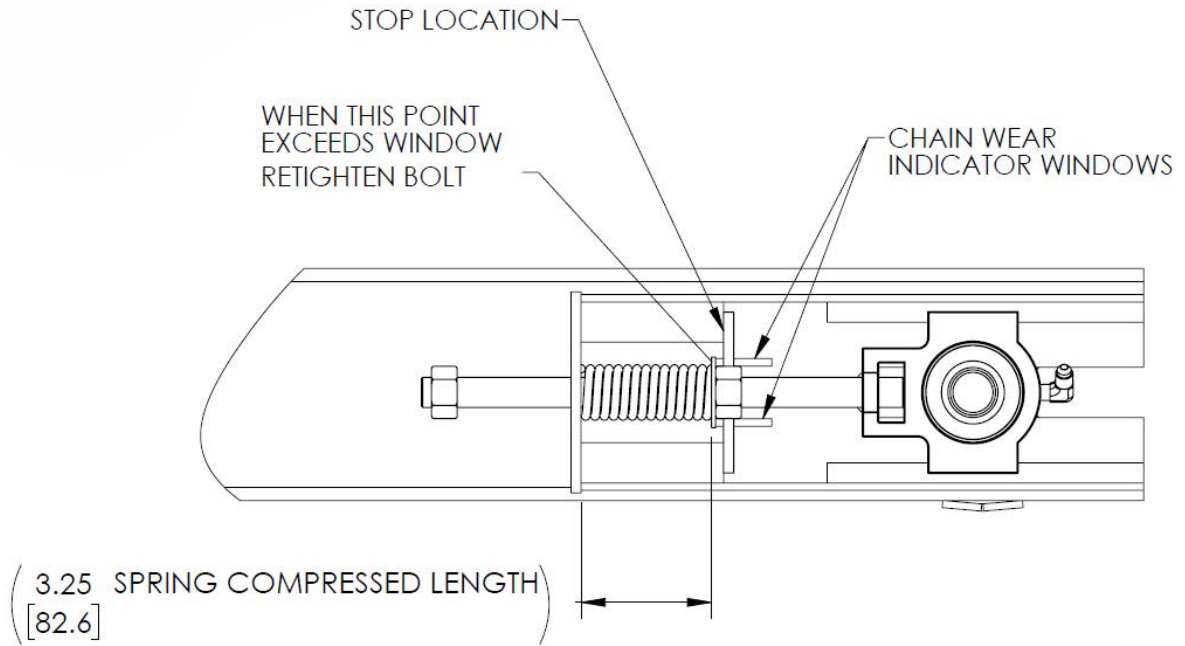

MAINTENANCE

MAINTENANCE

Preventative Maintenance Pays!

The handling and spreading of salt and sand is a highly severe operation with respect to metal corrosion. Establish a frequent, periodic preventative maintenance program to prevent rapid deterioration to equipment. Proper cleaning, lubrication and maintenance will yield longer life, more satisfactory service and more economical use of your equipment.

⚠ WARNING

Shut off all power and allow all moving parts to come to rest before performing any maintenance operation.

⚠ WARNING

Shut off all power and allow all moving parts to come to rest before performing any maintenance operation. Failure to comply may result in injury.

Hydraulic System

The use of proper oil in the hydraulic system is one of the most important factors for satisfactory operation. Utmost cleanliness in handling the oil cannot be stressed enough. Keep the hydraulic oil in original closed containers, clean top of container before opening and pouring, and handle in extremely clean measures and funnels.

Refer to the "Lubricant and Hydraulic Oil Specifications" section for selection of the proper hydraulic fluid for use in the hydraulic system.

⚠ DANGER

Do not check leaks with hands while system is operating as high pressure leaks can be dangerous! If skin is pierced with hydraulic fluid at high pressure seek immediate medical attention as fluid injected into the skin could cause gangrene if left untreated. Relieve pressure before disconnecting hydraulic lines or working with system. Make sure all hydraulic fluid connections are tight and all hydraulic hoses and lines are in good condition before applying pressure to the system. Wear protective gloves and safety glasses or goggles when working with hydraulic systems.

⚠ WARNING

DO NOT check for hydraulic leaks adjacent to moving parts while system is operating as there may be danger of entanglement!

Service Schedule

1. Check the hydraulic oil daily. Add oil if required. Periodically inspect the hoses and fittings for leaks.

NOTICE

CHANGE THE HYDRAULIC OIL FILTER AFTER THE FIRST WEEK (OR NOT MORE THAN 50 HOURS) OF OPERATION ON A UNIT.

2. After first filter change, replace filter when indicator reaches Danger Zone.
3. The reservoir should be drained through drain plug (not through suction outlet), flushed, and refilled annually, or the oil should be changed if it shows any signs of breaking down under continued high-pressure operation. Discoloration of oil is one sign of breakdown.

Lubrication and Maintenance Continued

Hydraulic Hose

Hose assemblies in operation should be inspected frequently for leakage, kinking, abrasion, corrosion or other signs of wear or damage. Worn or damaged hose assemblies should be replaced immediately.

⚠ WARNING

Testing should be conducted in approved test stands with adequate guards to protect the operator.

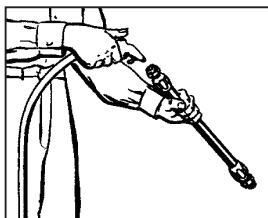

Clean

Clean assembly by blowing out with clean compressed air. Assemblies may be rinsed out with mineral spirits if the tube stock is compatible with oil, otherwise hot water at 150°F (65.55° C) maximum may be used.

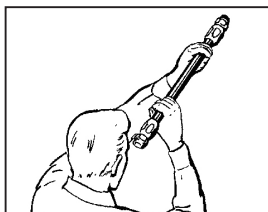

Inspect

Examine hose assembly internally for cut or bulged tube, obstructions, and cleanliness. For segment style fittings, be sure that the hose butts up against the nipple shoulder; band and retaining ring are properly set and tight, and segments are properly spaced. Check for proper gap between nut and socket or hex and socket. Nuts should swivel freely. Check the layline of the hose to be sure the assembly is not twisted. Cap the ends of the hose with plastic covers to keep clean.

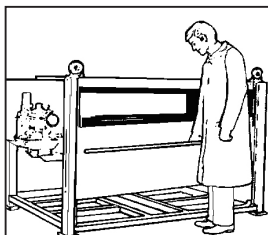

Test

The hose assembly should be hydrostatically tested at twice the recommended working pressure of the hose.

Test pressure should be held for not more than one minute and not less than 30 seconds. When test pressure is reached, visually inspect hose assembly for: 1. Any leaks or signs of weakness. 2. Any movement of the hose fitting in relation to the hose. Any of these defects are cause for rejection.

Storage and Handling

Hose should be stored in a dark, dry atmosphere away from electrical equipment, and the temperature should not exceed 90° F (32.22° C).

Lubrication and Maintenance Continued

Conveyor Chain

Hose down unit and remove any material build-up on sprockets and under chain.

NOTICE

The conveyor will move away from the bottom panel if material accumulates under the conveyor or on the sprockets. The more material that accumulates, the closer the chain will come to the chain shields. If the conveyor should catch a chain shield, it could permanently damage the conveyor, the chain shields or the unit. Do not remove material while conveyor or spinner is running!

Lubricate conveyor chain at least once a week. Shut down spinner and run conveyor slowly to lubricate chain. Use a mixture of 75% diesel fuel and 25% SAE 10 oil in a pressurized hand spray gun. Spray oil mixture between links of chain through openings provided at rear end of sill or from front outside body when clearance is adequate. Do this at least once a week and after each unit washing. Allow to dry before lubricating.



DANGER

Stay out of body when conveyor is running. Stay clear of all moving parts. Entanglement of clothes, any part of your body or anything you have in your hands can cause serious injury. Do not use bar, rod or hammer on conveyor while it is moving—if it gets caught it could cause injury!

Proper chain tension is also a factor in chain and sprocket life. The proper chain tension is illustrated in Figure 1. Be sure the chain is tensioned equally on both sides. This adjustment is made on each side of the unit at the idler bearings.

Figure 1- Chain Tension to be Measured from Rear of Sill- Proper Tension 26 to 30 inches (660mm to 762mm).

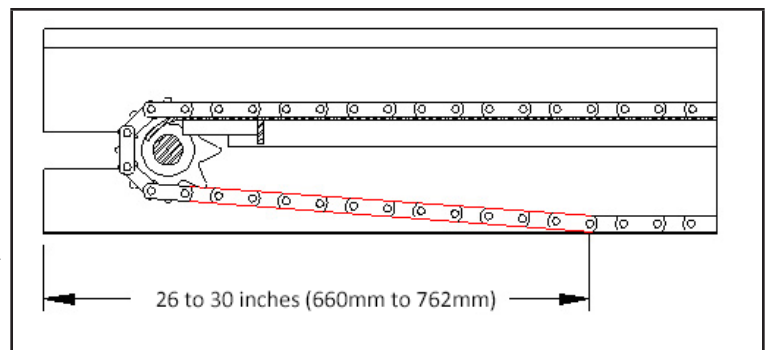

Figure 1 - Adjusting Chain Tension

Conveyor chains that are too tight will tend to stretch. This will cause excess sprocket wear and eventually cause breakage. Excess slack presents the possibility of the chain catching on sub-frame parts. Bent or distorted chain bars will cause damage to the body as well. Straighten or replace bent or distorted chain bars immediately.

Lubrication and Maintenance Continued

Conveyor Replacement

Check drive and idler sprockets for wear and replace if necessary.

Removal

Uninstall spinner from spreader. Remove spreader from truck. Rotate conveyor so that connecting link pins, attached with cotter pins, can be accessed at rear of spreader. Loosen idler screws on both sides. Remove cotter pins and connecting link pins at rear of unit. Take chain off rear sprockets and pull chain from front of unit.

Installation

1. Remove connecting link pins from the new chain. Lay the new chain at the front of the unit with the chain bars up/HI-WAY stamps down and the barrel end of the connecting link pointing towards the unit (See Figure 2).
NOTE: Installation is easier if the new conveyor can be elevated so it is level with the spreader bottom.
2. Insert the conveyor between the bottom panel and the cross angles with the barrel end first. Pull conveyor to rear of unit.
3. Slide the remaining half of conveyor on top of the bottom panel with the open end of the master link first (See Figure 2).
4. Push the chain along the bottom panel until the connecting link reaches the rear of the unit so the ends meet at rear.
5. Make sure the chain is positioned on all the sprockets. Install the connector link pins previously removed.
NOTE: you may have to rotate the sprockets by hand to align the link's pin holes.

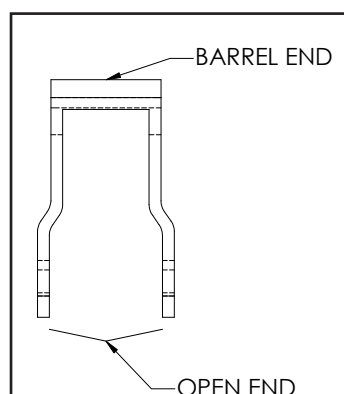

Figure 2 – Chain Link

Tension the chain by tightening the idler screws. Reinstall spinner assembly and install the spreader into the truck. Be sure to lubricate the idler bearings and chain before operation.

Make sure the drive sprocket drives against the barrel end of the links—Not against the connecting pins.

Open ends of chain links point towards rear of unit on top of bottom panel. Likewise, open ends point towards front of unit underneath bottom panel.

Lubrication and Maintenance Continued

Conveyor Gearcase

Drain oil in a new unit after first two weeks (or not more than 100 hours) of operation, and flush gear case thoroughly with light oil. Refer to “Lubricant and Hydraulic Oil Specifications” section for proper grade oil and recommended amounts of lubricant. After initial change, oil should be changed every 2,000 hours of operation or annually, whichever occurs first.

Check gearcase oil level monthly.

Lubrication of Bearings

Grease in a bearing acts to prevent excessive wear of parts, protects ball races and balls from corrosion and aids in preventing excessive heat within the bearing. It is very important the grease maintains its proper consistency during operation. It must not be fluid and it must not channel.

Make sure all fittings are thoroughly cleaned before grease is injected. Points to be lubricated by means of a grease gun have standard grease fittings.

Lubricate bearings by pumping grease slowly until it forms a slight bead around the seals. This bead indicates adequate lubrication and also provides additional protection against the entrance of dirt.

Fasteners

Tighten all screw fasteners to recommended torques after first week of operation and annually thereafter. If loose fasteners are found at anytime, tighten to recommended torque. Replace any lost or damaged fasteners or other parts immediately. Check body mounting hardware every week.

Clean-Up

NOTICE

High pressure wash can inject water and/or salt into bearing seals and control components, causing damage. Use caution when cleaning these areas.

Thoroughly wash unit every two to three days during the operating season to maintain minimal maintenance operation. Hose unit down under pressure to free all sticky and frozen material.

It is important the unit be thoroughly cleaned at the end of each operating season. All lubrication and maintenance instructions should be closely followed. Repaint worn spots to prevent formation of rust.



Lubricant and Hydraulic Oil Specifications

NOTICE

The lubricant distributor and/or supplier is to be held responsible for the results obtained from their products. Procure lubricants from distributors and/or suppliers of unquestionable integrity, supplying known and tested products. Do not jeopardize your equipment with inferior lubricants. No specific brands of oil are recommended. Use only products qualified under the following oil viscosity specifications and classification recommended by reputable oil companies.

Hydraulic System

The following are the recommended procedures for selecting the proper hydraulic fluid for use in the hydraulic system. Select a major brand industrial PREMIUM QUALITY (anti-wear type) hydraulic oil to provide viscosity between 100-200 SSU at operating temperature. Premium hydraulic oils with viscosity indexes of 95 or above will provide the following temperature ranges :

INDUSTRY IDENTIFICATION VISCOSITY GRADE	OPERATING TEMPERATURE	VISCOSITY
150 SSU	122° F (50° C) 84° F (28.9° C)	100 SSU 200 SSU
225 SSU	140° F (60° C) 107° F (41.7° C)	100 SSU 200 SSU
300 SSU	150° F (66.6° C) 116° F (46.1° C)	100 SSU 200 SSU
450 SSU	165° F (73.9° C) 130° F (54.5° C)	100 SSU 200 SSU
600 SSU	182° F (83.3° C) 145° F (62.8° C)	100 SSU 200 SSU

If, because of necessity or convenience, it is desirable to use an automotive engine oil, multi-viscosity oils of SC rating (formerly MS quality) which will provide between 100-200 SSU at operating temperature can be used. These will provide proper viscosity over a wide range. For example:

SAE VISCOSITY GRADE	OPERATING TEMPERATURE	VISCOSITY
10W-30	130° F (54.5° C)	100 SSU
	100° F (37.8° C)	200 SSU
10W-40	190° F (87.8° C)	100 SSU
	140° F (60° C)	200 SSU



Lubricant and Hydraulic Oil Specifications Continued

Gearcase Lubricant

Gear cases are factory equipped with synthetic oil for best performance at high loads. Lubricate the gear case with multi-purpose gear lubricating oil conforming to MIL-L2105B according to the chart below:

Part	Refill Quantity	40° to 120° F (4.5° C)	Below 40° F (49° C)
Gearcase	.75 pints (.35 liters)	SAE 85W 140	SAE 88W 90

Grease Gun Lubricant

Use a waterproof ball and roller bearing lithium base lubricant with a minimum melting point of 300° F (149° C). This lubricant should have a viscosity which assures easy handling in the pressure gun at prevailing atmospheric temperatures. The grease should conform to NLGI No. 2 consistency.



Lubrication Chart



WARNING Shut off all power and allow all moving parts to come to rest before performing any maintenance operation.

The spreader should be regularly lubricated with the lubricants recommended in this manual in accordance with the following chart:

LOCATION	PLACES	METHOD	FREQUENCY
Pump Drive			
Trans. PTO- Slip Yoke	1	Grease Gun	Weekly
Trans. PTO- Universal Joint	2	Grease Gun	Monthly
Crankshaft PTO- Sliding Spline	1	Grease Gun	Weekly
Crankshaft PTO- Universal Joint	2	Grease Gun	Monthly
Crankshaft PTO- Pipe Plug on Cast Mounting Plate	1	Oil	Annually
Hydraulic System			
Reservoir	1	Check Daily; Change Annually	
Filter	1	Check Daily; Change when indicator is red	
Hydraulic Cylinder Pins	4	Grease Gun	Monthly
Body			
Dump Body and Pivot Shaft	6	Grease Gun	Monthly
Conveyor			
Bearings- Drive and Idler	4	Grease Gun	Weekly
Take-up Screws	2	Hand Grease	Monthly
Chain	2 Strands	Spray Oil	Weekly
Feedgate			
Jack Assembly- Gears	1	Hand Grease	Annually
Tube	1	Grease Gun	Monthly

NOTE: Unusual conditions, such as excessive dust, temperature extremes or excessive moisture may require more frequent lubrication of specific parts.

* See "Lubricant and Hydraulic Oil Specifications" for types of lubricants and oil to be used.



CAP SCREW GRADE IDENTIFICATION- MARKINGS ON HEAD

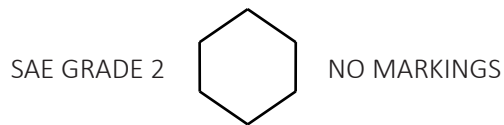

USE GRADE 2 TORQUES FOR STAINLESS STEEL FASTENERS AND CARRIAGE BOLTS.

CAP SCREW SIZE	TORQUE- FOOT-POUNDS					
	GRADE 2		GRADE 5		GRADE 8	
	DRY	LUBE	DRY	LUBE	DRY	LUBE
1/4"	5	4	8	6	12	9
5/16"	11	8	17	13	25	18
3/8"	20	15	30	23	45	35
7/16"	30	24	50	35	70	55
1/2"	50	35	75	55	110	80
9/16"	65	50	110	80	150	110
5/8"	90	70	150	110	220	170
3/4"	100	120	260	200	380	280
7/8"	140	110	400	300	600	460
1"	220	160	580	440	900	650

This page is intentionally left blank.

PARTS

PARTS

Instructions for Ordering Parts

Order from the AUTHORIZED DEALER in your area.

Always give the pertinent model and serial number.

Give part name, part number and the quantity required.

Give the correct address to where the parts are to be shipped, and the carrier if there is a preference.

Unless claims for shortages or errors are made immediately upon receipt of goods they will not be considered. Any part returns should be directed through the dealer from which they were purchased.

When broken goods are received, a full description of the damage should be made by the carrier agent on the freight bill. If this description is insisted upon, full damage can always be collected from the transportation company.

No responsibility is assumed for delay or damage to merchandise while in transit. Our responsibility ceases upon delivery of shipment to the transportation company from whom a receipt is received showing that shipment was in good condition when delivered to them, therefore, claims (if any) should be filed with the transportation company and not with New Leader Manufacturing.

If your claims are not being handled (by the transportation company) to your satisfaction, please call our Product Sales & Support Department at New Leader Manufacturing at 888-363-8006 for assistance.

In the parts list the following symbols and abbreviations stand for:

* - Not Shown
AR – As Required
CS – Carbon Steel
SS – Stainless Steel
NS – Not Serviced

The parts listed under the different steel types (CS, 409 SS and 304 SS) are for that type of unit and do not necessarily mean the part is made of that type of steel.



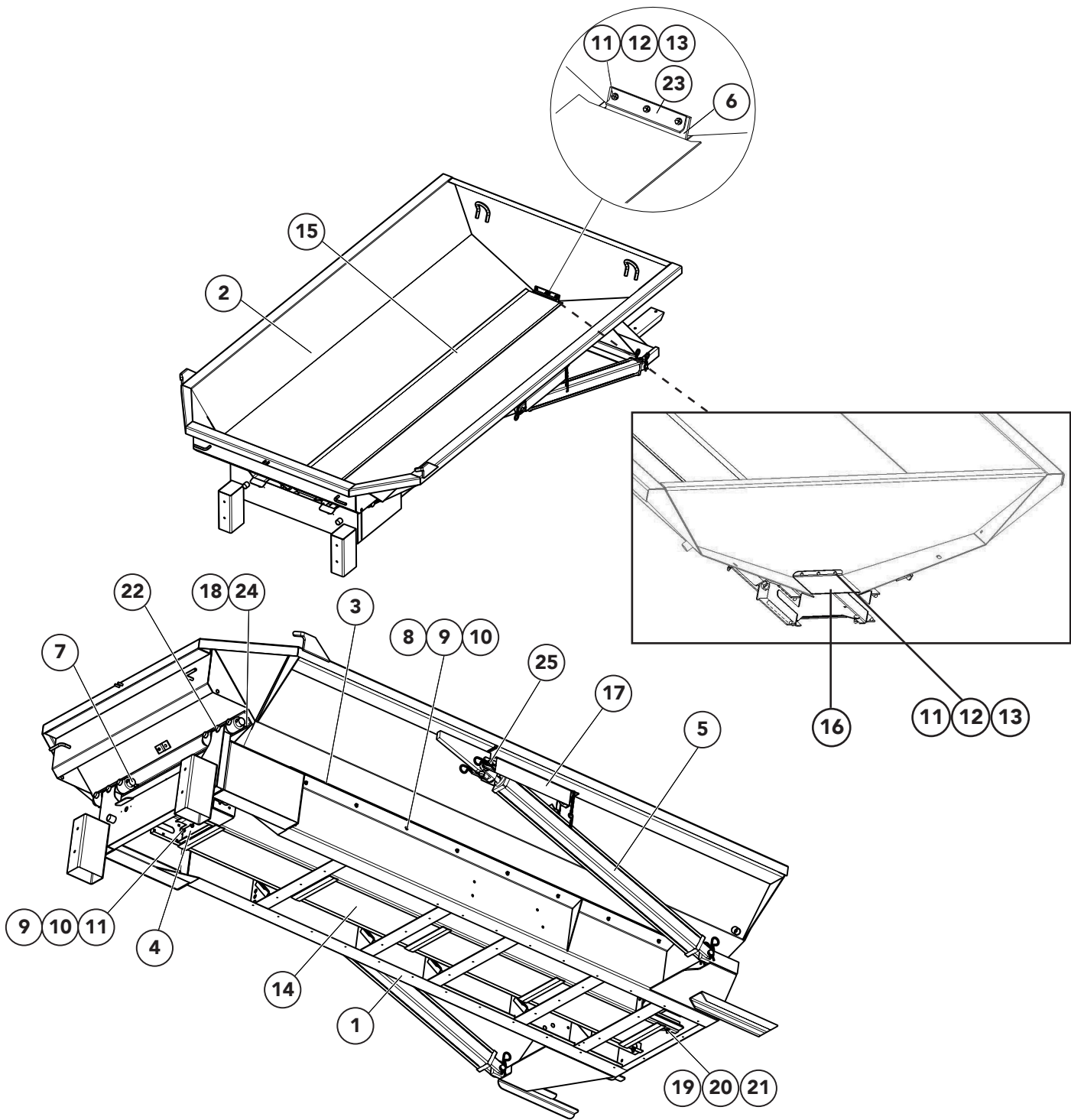

Body & Subframe Continued

ITEM	PART NO.		DESCRIPTION	QTY
	CS	304 SS		
1	85146	317516	SUBFRAME WELDMENT	1
2	85145	317513	BODY WELDMENT	1
3	84480	84480	STRIP – PLASTIC	2
4	27141	27141	WIPER – BELT	1
5	84481	84481	CYLINDER – HYDRAULIC	2
6	85074	85074	WIPER – BELT FRONT	1
7	85120	85120	PIVOT – SHAFT	2
8	85864	85864	BOLT – ELEVATOR 1/4-20 NC x 1 SS	18
9	36418	36418	WASHER – LOCK 1/4 SS	18
10	36412	36412	NUT – HEX 1/4-20 NC SS	18
11	20005	36395	CAP SCREW – 1/4-20 NC x 1	8
12	20710	36418	WASHER – LOCK 1/4	8
13	20642	36412	NUT – HEX 1/4-20 NC	8
14	85905	317521	PANEL – COVER WELDMENT	1
15	85890	317514	COVER – CONVEYOR WELDMENT	1
16	85851	317519	COVER – FRONT	1
17	85889	317515	PROP – SAFETY WELDMENT	2
18	21024	96247	PIN – CLEVIS	4
19	20318	36408	BOLT – CARRIAGE 3/8-16 NC x 1-1/4	2
20	20712	36420	WASHER – LOCK 3/8	2
21	20644	36414	NUT – HEX 3/8-16 NC	2
22	6072	311663	ZERK – GREASE	10
23	85862	317518	RETAINER – BELT FRONT	1
24	20817	36427	PIN – COTTER	4
25	85888	85888	PIN – HYDRAULIC CYLINDER	2



<u>ITEM</u>	<u>PART NO.</u>	<u>DESCRIPTION</u>	<u>QTY</u>
	<u>CS</u>	<u>304 SS</u>	
1	*313051	*317529 PLATE - MOUNTING REAR	2
2	*313054	*317530 ANGLE - MOUNTING REAR	2
3	*313052	*317531 ANGLE - MOUNTING DRIVER'S SIDE	1
4	*313053	*317532 ANGLE - MOUNTING PASS. SIDE	1
5	*313057	*317533 MOUNT - SPRAY NOZZLE	2
6	*313058	*317534 MOUNT - PUMP CALCIUM	1
7	*313059	*317535 MOUNT - PUMP CALCIUM	1
8	*313060	*317536 ANGLE - TEMP SENSOR	1
9	*313066	*317537 BRACKET - SENSOR BODY UP	1

* - Not Shown

Bumper

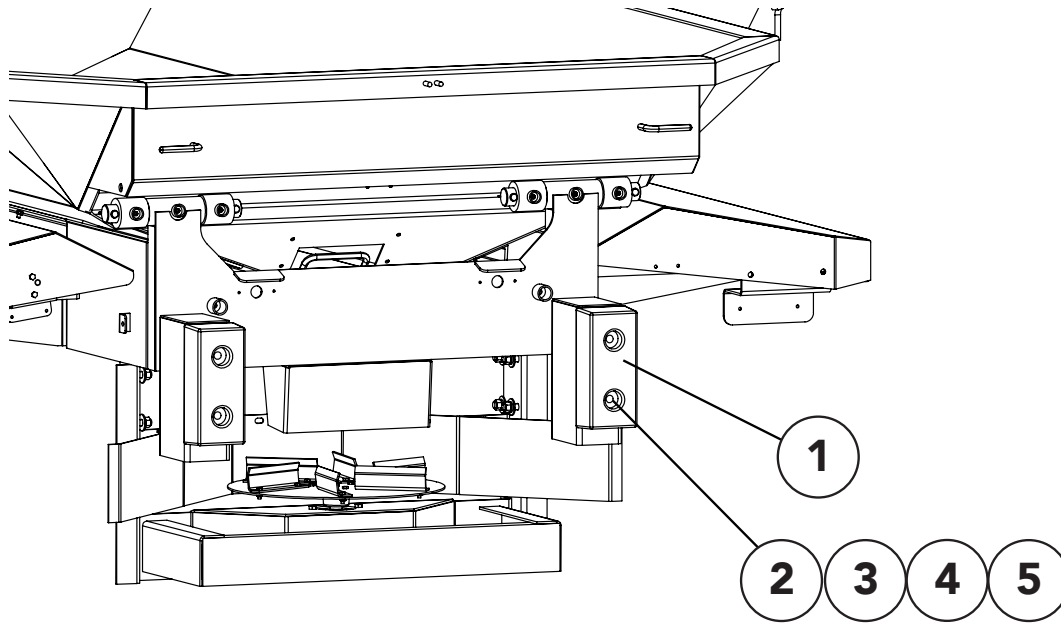

<u>ITEM</u>	<u>PART NO.</u>	<u>DESCRIPTION</u>	<u>QTY</u>
	<u>CS</u>	<u>304 SS</u>	
1	85885	85885 BUMPER – EXTRUDED RUBBER 10"	2
2	20133	42454 CAP SCREW - 1/2-13 NC x 2-1/2	4
3	20646	36416 NUT - HEX 1/2-13 NC	4
4	20695	36426 WASHER - FLAT 1/2	4
5	20714	36422 WASHER - LOCK 1/2	4

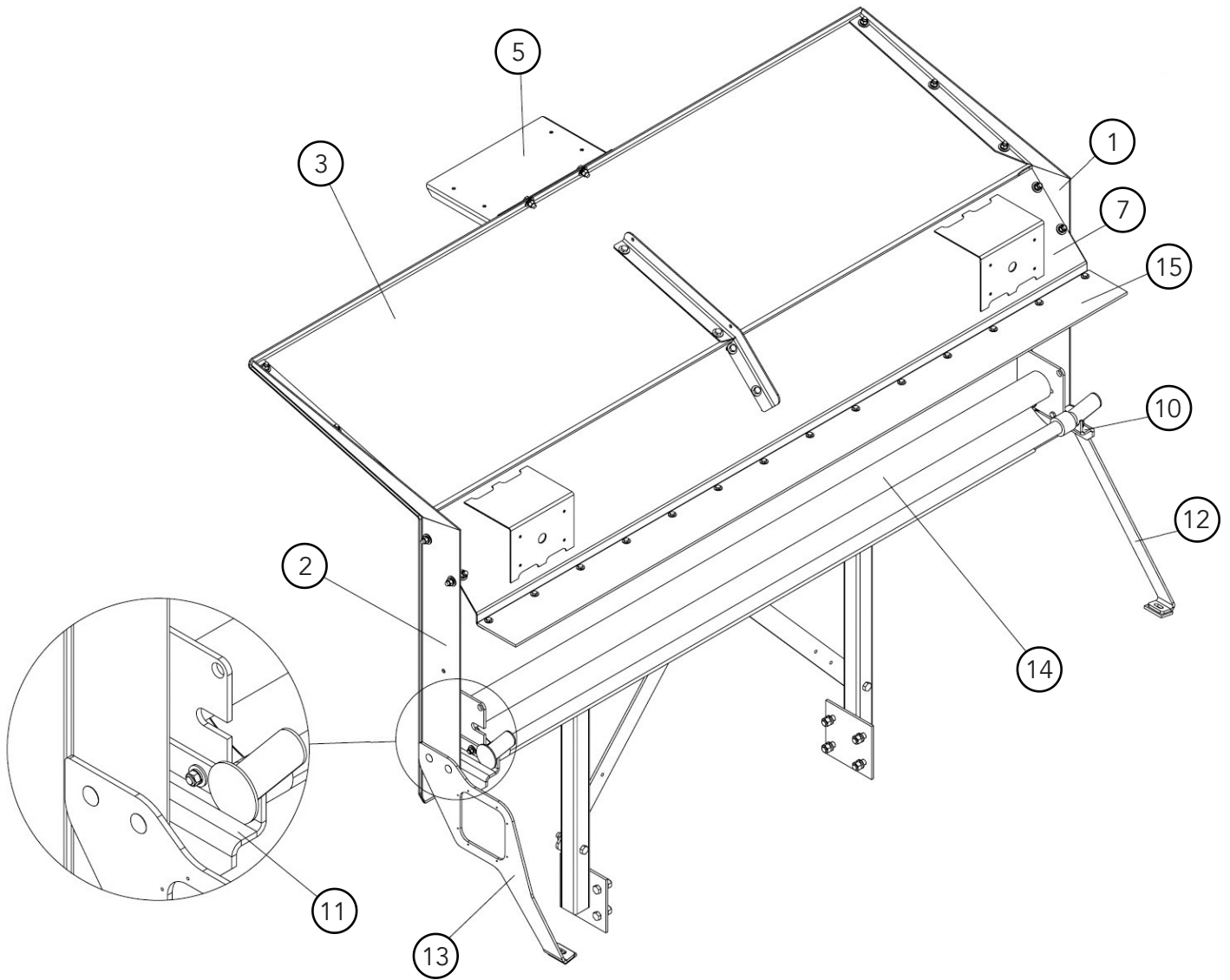

Cab Shield Continued

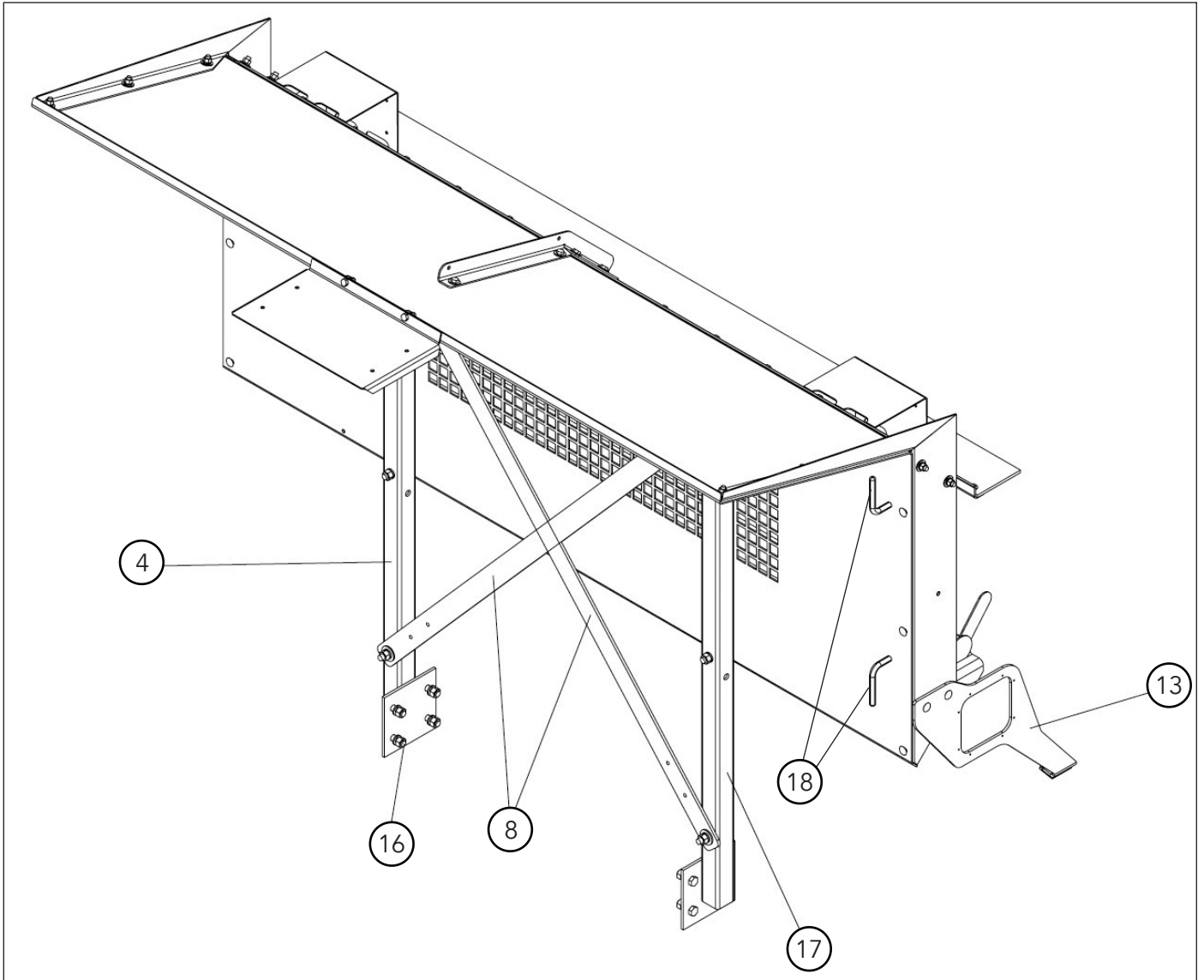

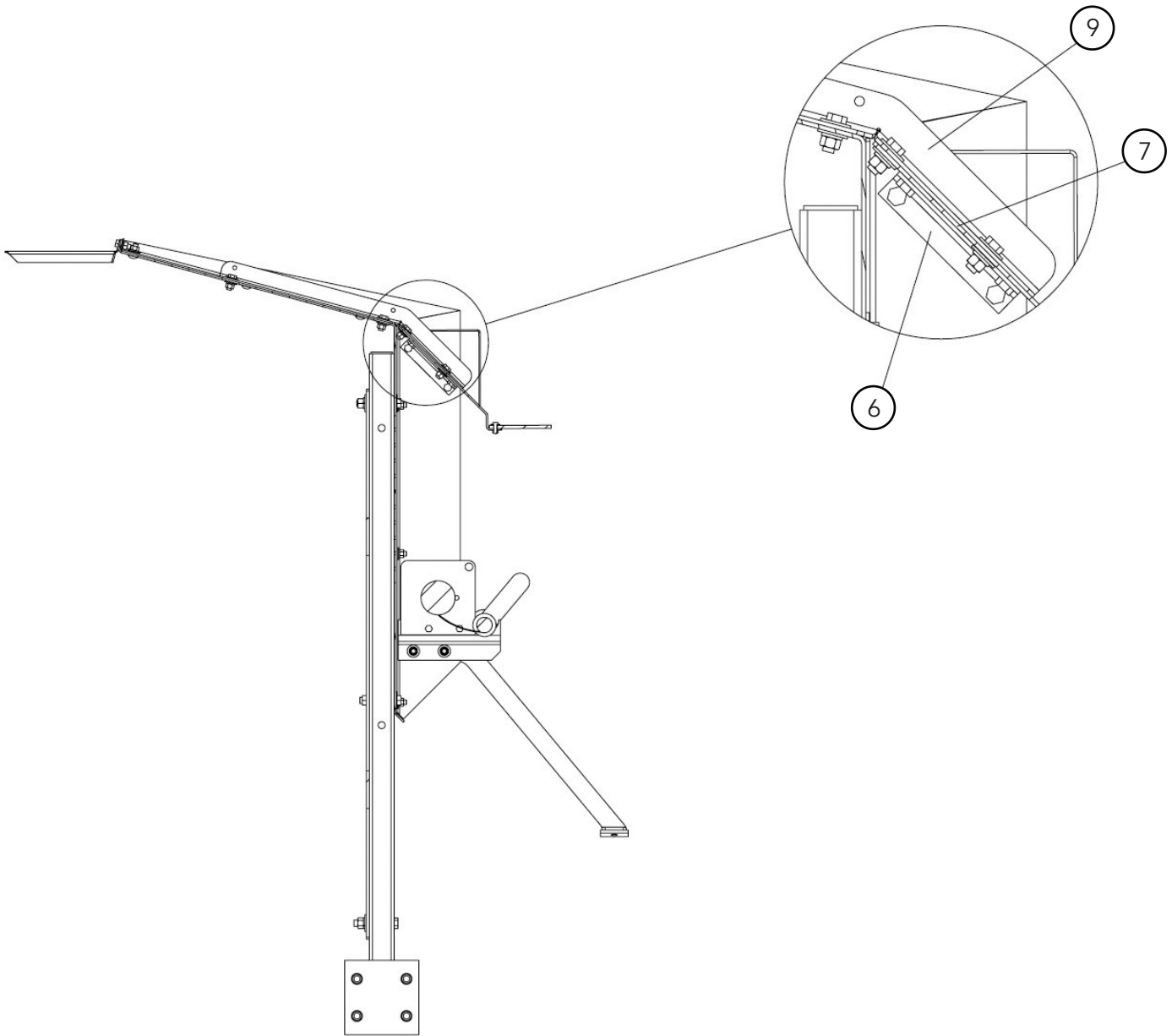

Cab Shield Continued

<u>ITEM</u>	<u>PART NO.</u>	<u>DESCRIPTION</u>	<u>QTY</u>
	<u>CS</u>	<u>304 SS</u>	
	96397	317508 CAB SHIELD	
1	96387	317607 SUPPORT – WELDMENT RH EXT.	1
2	96388	317608 SUPPORT – WELDMENT LH EXT.	1
3	96386	317713 PANEL – CAB SHIELD	1
4	322785	322783 UPRIGHT – WELDMENT RH	1
5	85972	317610 BRACKET – STROBE LIGHT	1
6	85903	317612 BRACKET – GUARD TARP	1
7	312949	317613 GUARD – WLDMT TARP EXT.	2
8	85967	317611 STIFFENER – CAB SHIELD	1
9	312947	317614 ANGLE - SUPPORT CAB SHIELD	2
10	88852	317615 BRACKET – TARP LH	1
11	88853	317616 BRACKET – TARP RH	1
12	312555	317609 BRACKET – SUPPORT CAB SHIELD	1
13	322757	322756 SUPPORT – WELDMENT RH	1
14	85883	85883 TARP	1
15	97997	97997 BELT – TARP GUARD	1
16	96392	317618 HARDWARE KIT – CAB SHIELD	1
17	322800	322799 UPRIGHT – WELDMENT LH	1
18	322133	322135 TIE – WELDMENT	2



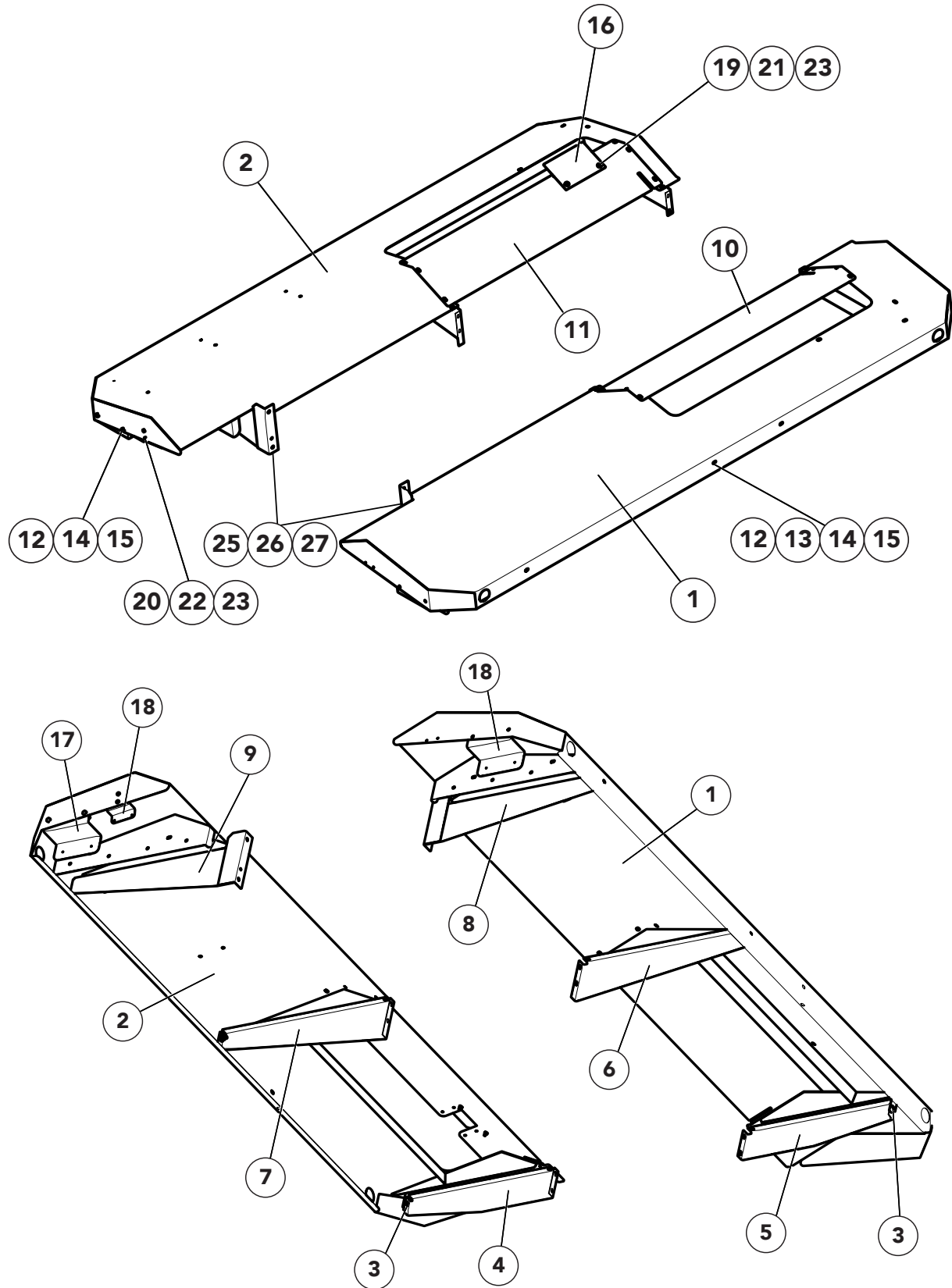

Fenders Continued

<u>ITEM</u>	<u>PART NO.</u>	<u>DESCRIPTION</u>	<u>QTY</u>
	CS	304 SS	
1	84490	317578 FENDER - RH WELDMENT	1
2	84491	317579 FENDER - LH WELDMENT	1
3	85985	317580 SUPPORT - FENDER	2
4	85984	317581 MOUNTING - FENDER LH	1
5	85998	317582 MOUNTING - FENDER RH	1
6	85128	317583 MOUNTING - FENDER RH	1
7	85129	317584 MOUNTING - FENDER LH	1
8	98998	317585 MOUNTING - FENDER RH	1
9	98999	317586 MOUNTING - FENDER LH	1
10	85983	317587 COVER - FENDER PANEL RH	1
11	85983-X1	317588 COVER - FENDER PANEL LH	1
12	20319	36409 BOLT - CARRIAGE 3/8-16 NC x 1-1/4	34
13	20693	36425 WASHER - FLAT 3/8	34
14	20712	36420 WASHER - LOCK 3/8	38
15	20644	36414 NUT - HEX 3/8-16 NC	38
16	312547	312547 FLAP - FUEL FILL	1
17	312548	317589 BRACKET - LIGHT MOUNT	2
18	312549	317590 BRACKET - BACKUP ALARM	1
19	20691	36423 WASHER - FLAT 1/4	2
20	20710	36418 WASHER - LOCK 1/4	2
21	20676	42034 NUT - LOCK 1/4-20 NC	2
22	20642	36412 NUT - HEX 1/4-20 NC	2
23	20005-X1	36395 CAP SCREW - 1/4-20 NC x 1 GR8	4
24	20068-X1	36399 CAP SCREW - 3/8-16 NC x 1-1/4 GR8	4
25	20128-X1	36402 CAP SCREW - 1/2-13 NC x 1-1/4 GR8	4
26	20714	36422 WASHER - LOCK 1/2	4
27	20646	36416 NUT - HEX 1/2-13 NC	4



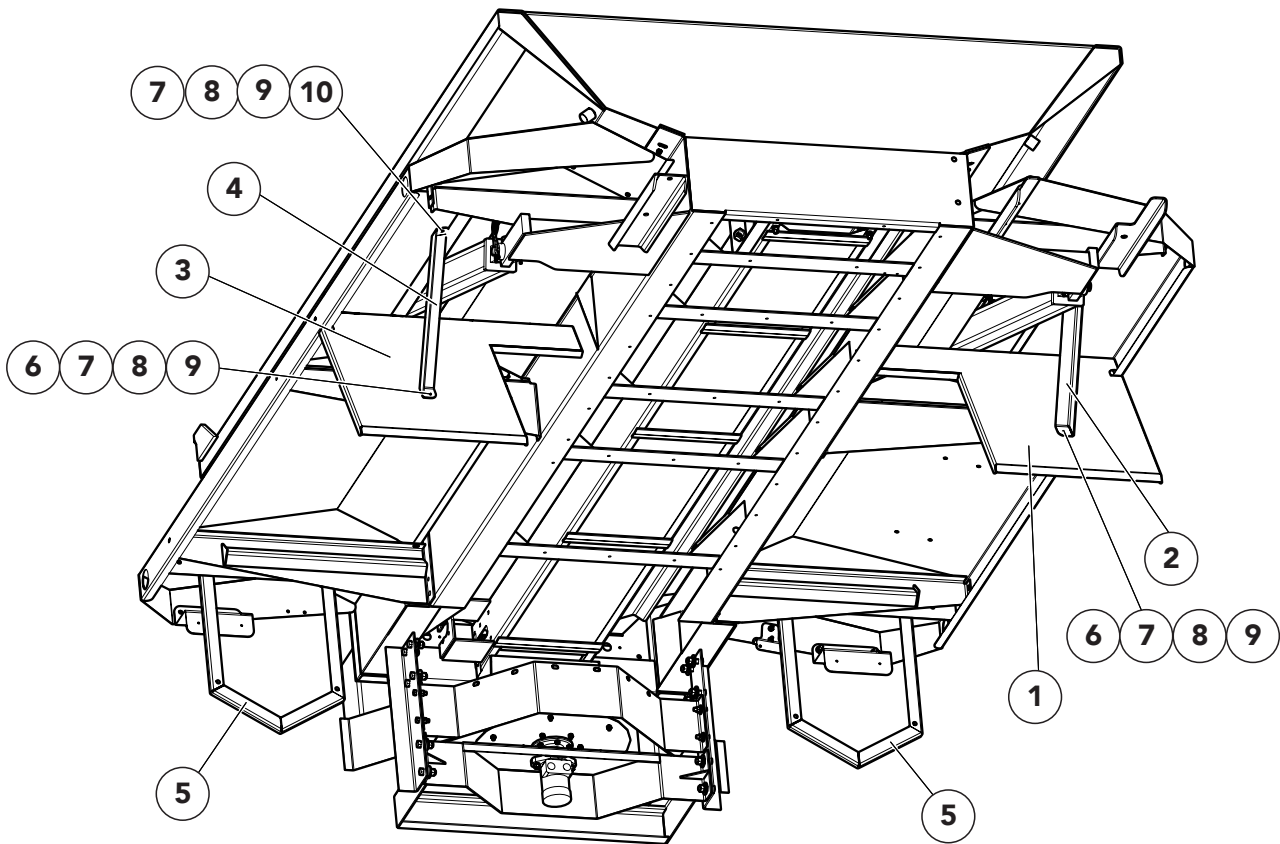

<u>ITEM</u>	<u>PART NO.</u>	<u>DESCRIPTION</u>	<u>QTY</u>
	CS 304 SS		
	312550	317511 KIT - STONE SHIELDS, INCLUDES 1 - 10	
1	313003	317623 STONE SHIELD - WLDMT LH	1
2	313008	317625 SUPPORT - STONE SHIELD LH	1
3	313004	317626 STONE SHIELD - WLDMT RH	1
4	313009	317624 SUPPORT - STONE SHIELD RH	1
5	312553	317627 BRACKET - ANTISAIL	2
6	20067	36398 CAP SCREW - 3/8-16 NC x 1	6
7	20693	36425 WASHER - FLAT 3/8	16
8	20712	36420 WASHER - LOCK 3/8	16
9	20644	36414 NUT - HEX 3/8-16 NC	16
10	20319	36409 BOLT - CARRIAGE 3/8-16 NC x 1-1/4	10

Shovel/Broom Mount

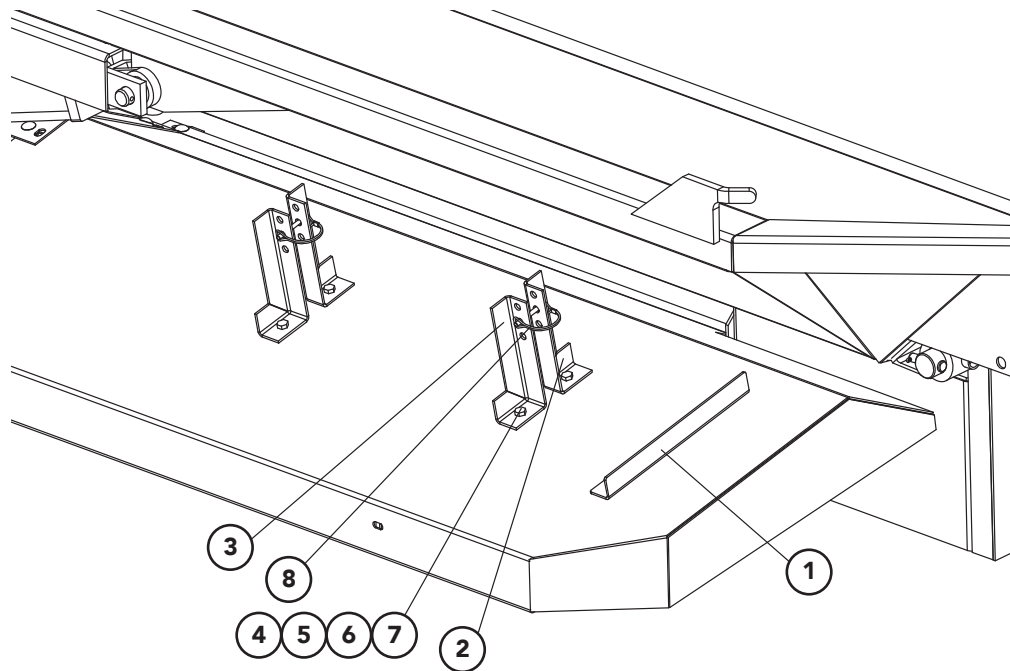

<u>ITEM</u>	<u>PART NO.</u>	<u>DESCRIPTION</u>	<u>QTY</u>	
	<u>CS</u>	<u>304 SS</u>		
	96396	317509	MOUNT – KIT SHOVEL/BROOM	
1	96393	317538	ANGLE – SHOVEL/BROOM HOLDER	1
2	96394	317539	ANGLE – WELDMENT RH SHOVEL/BROOM	2
3	96395	317540	ANGLE – WELDMENT LH SHOVEL/BROOM	2
4	20067	36398	CAP SCREW – 3/8 X 1	6
5	20694	36425	WASHER – FLAT 3/8	6
6	20712	36420	WASHER – LOCK 3/8	6
7	20644	36414	NUT – HEX 3/8	6
8	90727	90727	PIN – SNAP	2



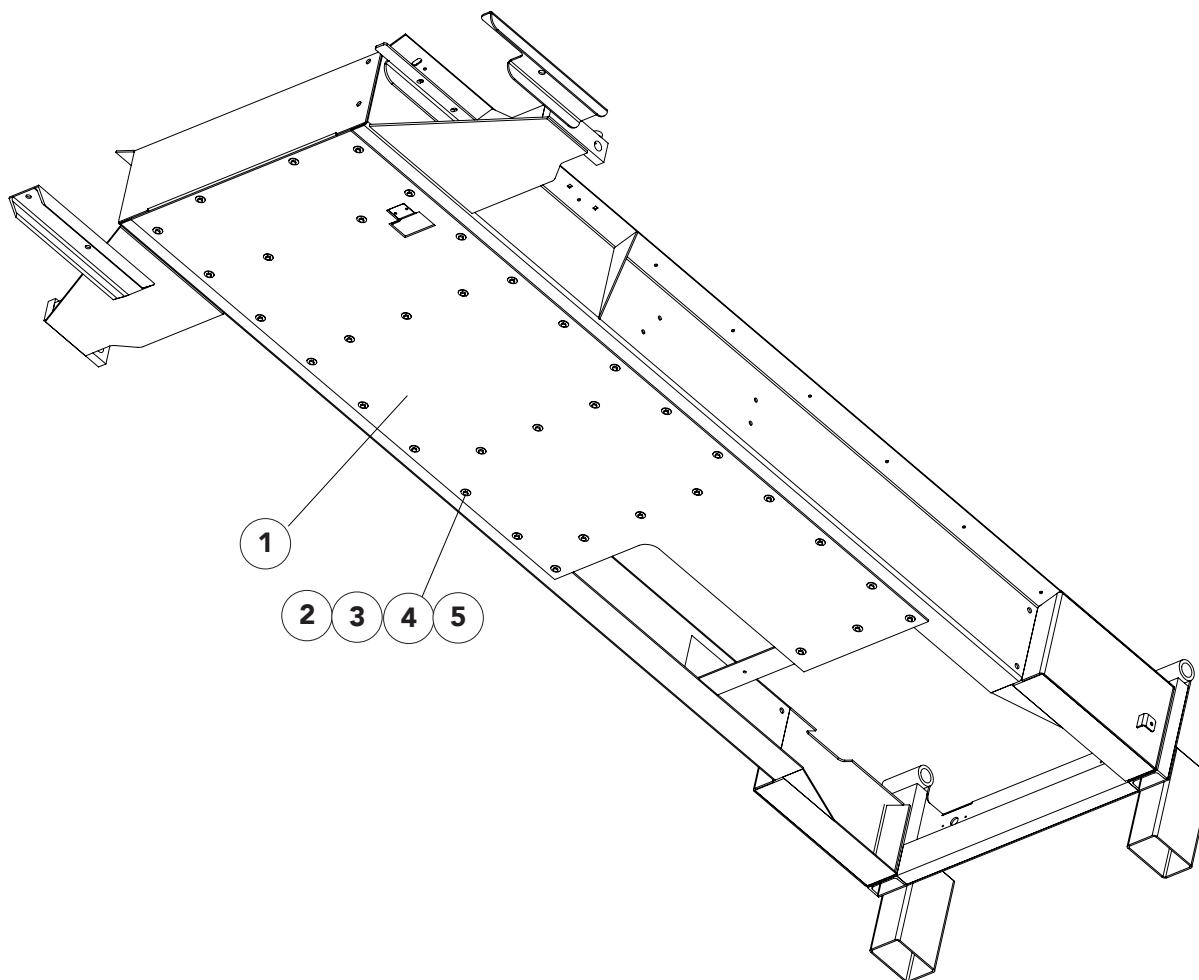

<u>ITEM</u>	<u>PART NO.</u>		<u>DESCRIPTION</u>	<u>QTY</u>
	<u>CS</u>	<u>304 SS</u>		
1	313064	313064	BELT - FRAME COVER	1
2	20005-X1	36395	CAP SCREW - 1/4-20 NC x 1 GR8	36
3	21423	21423-X1	WASHER - FLAT 1/4 SPECIAL	36
4	20710	36418	WASHER - LOCK 1/4	36
5	20642	36412	NUT - HEX 1/4-20 NC	36

Hydraulic Reservoir

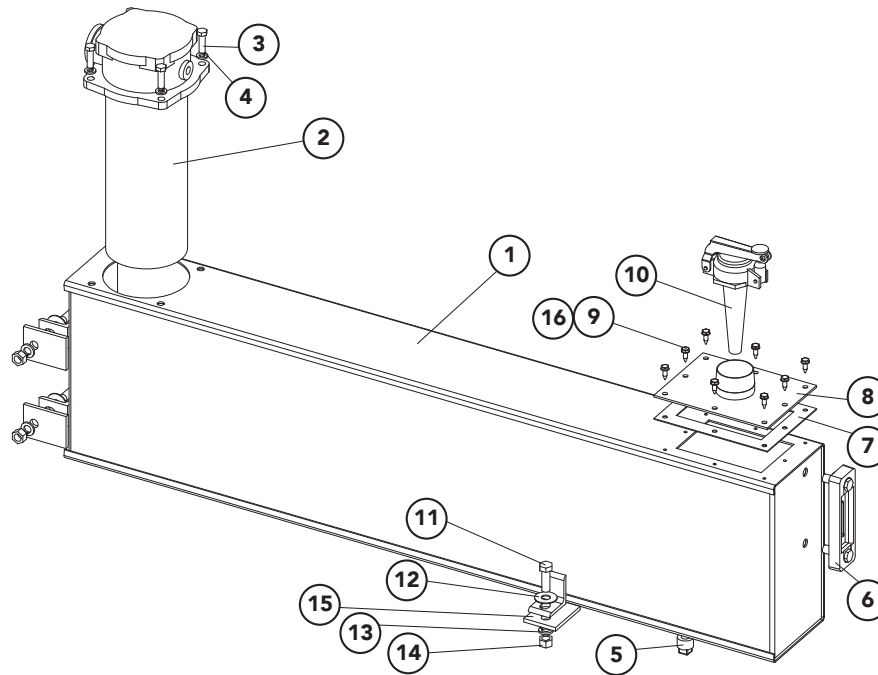

ITEM	PART NO.		DESCRIPTION	QTY
	CS	304 SS		
	85993	317591	RESERVOIR – HYDRAULIC ASSEMBLY	
1	85882	317593	RESERVOIR – HYDRAULIC WELDMENT	1
2	320792	32079	FILTER – HYDRAULIC	1
	320803	320803	ELEMENT – FILTER	1
3	20037	36397	CAP SCREW – 5/16 X 1-1/4	4
4	20711	76419	WASHER – LOCK 5/16	4
5	16011	16011	PLUG	1
6	38575	38575	GAUGE – SIGHT & TEMP.	1
7	85849	85849	GASKET - CLEANOUT	1
8	85891	317592	COVER - CLEANOUT	1
9	20003	36393	CAP SCREW – 1/4 X 3/4	8
10	21850-X1	21850-X1	CAP	1
11	20129	36539	CAP SCREW – 1/2 X 1-1/2	4
12	20695	36426	WASHER – FLAT 1/2	4
13	20714	36422	WASHER – LOCK 1/2	4
14	20646	36416	NUT – HEX 1/2	4
15	39158	39158	BELT – FLEX MOUNT	4
16	20710	36418	WASHER – LOCK 1/4	8
17	*6035	*6035	PIPE – PLUG 1-1/4	1
18	*6321	*6321	PIPE – PLUG 2	1

* - Not Shown



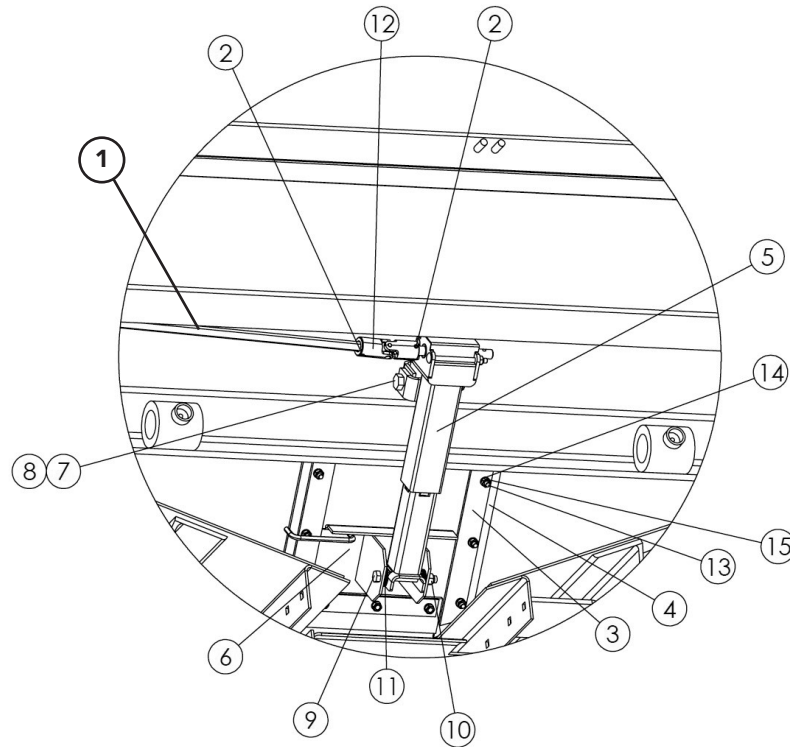

ITEM	PART NO.		DESCRIPTION	QTY
	CS	304 SS		
1	85966	317567	HANDLE - JACK FEEDGATE	1
2	312268	312268	PIN - ROLL .188 X 1.0 SS	2
3	84451	317568	BAR - SLIDE FEEDGATE	2
4	84452	317569	BAR - GUIDE FEEDGATE	2
5	312975	312975	JACK - ASSY 4.5 304	1
6	84456	317570	FEEDGATE - ASSY	1
7	20137	34581	CAPSCREW - .5-13NC X 3.5 GR5	1
8	20680	39016	NUT - LOCK .5-13NC ZN	1
9	20076	96879	CAPSCREW - .375-16NC X 3.25	1
10	20678	72054	NUT - LOCK .375-16NC ZN	1
11	20693	36425	WASHER - FLAT .375 ZN	6
12	85002	85002	JOINT - U	1
13	20264	71733	BOLT - CARRIAGE .25-20NC X 1	6
14	20710	36418	WASHER - LOCK .25 ZN	6
15	20642	36412	NUT - HEX .25-20NC ZN	6

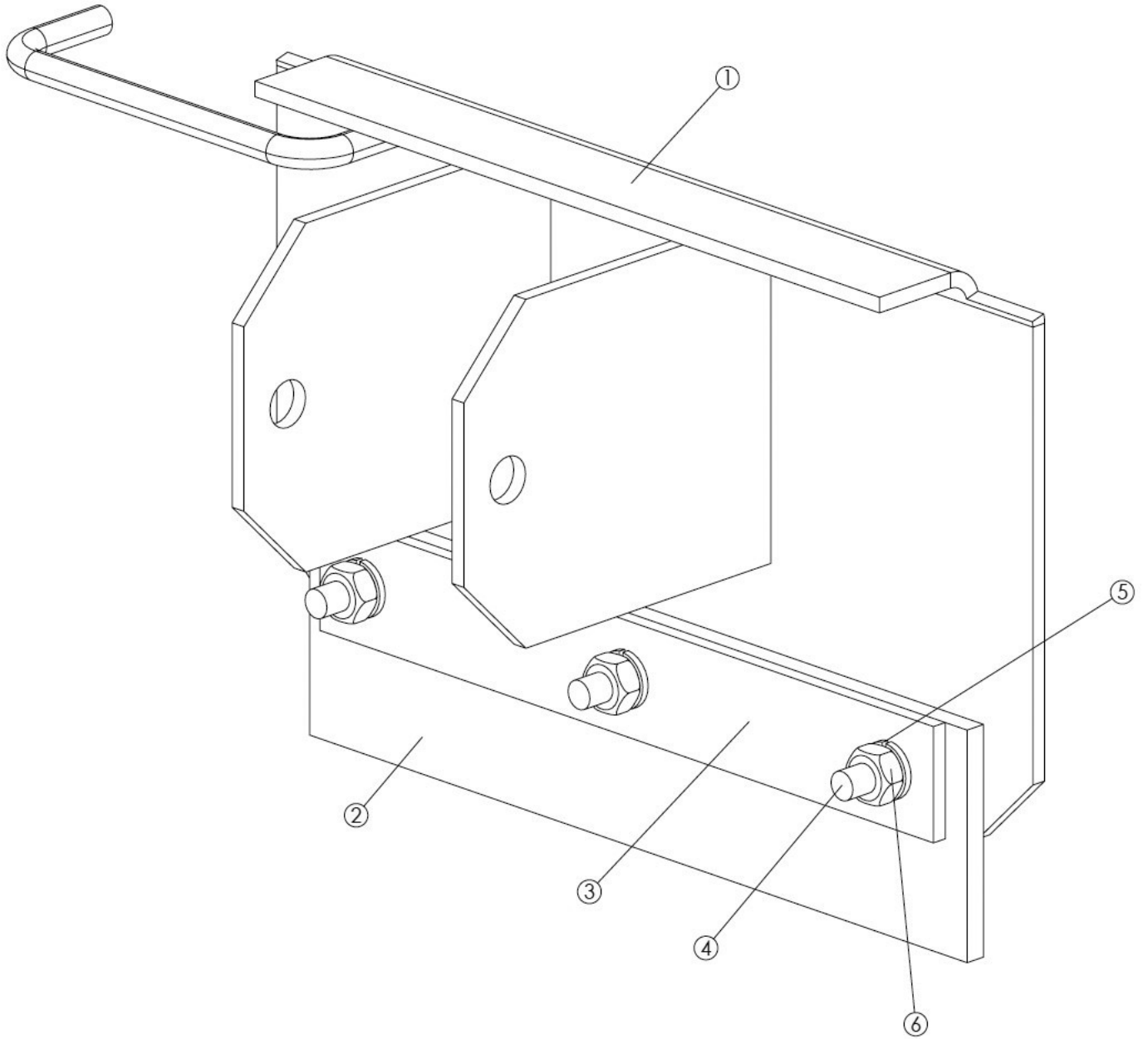

Feedgate Assembly

<u>ITEM</u>	<u>PART NO.</u>		<u>DESCRIPTION</u>	<u>QTY</u>
	<u>CS</u>	<u>304 SS</u>		
1	84455	317573	FEEDGATE - WLDMT PANEL	1
2	84454	84454	SEALER - BELT FEEDGATE	1
3	85075	317574	RETAINER - BELT FEEDGATE	1
4	20621	47268	SCREW - FLATHEAD .25-20NC X 1	3
5	20710	36418	WASHER - .25 ZN LOCK	3
6	20642	36412	NUT - .25-20NC ZN HEX	3

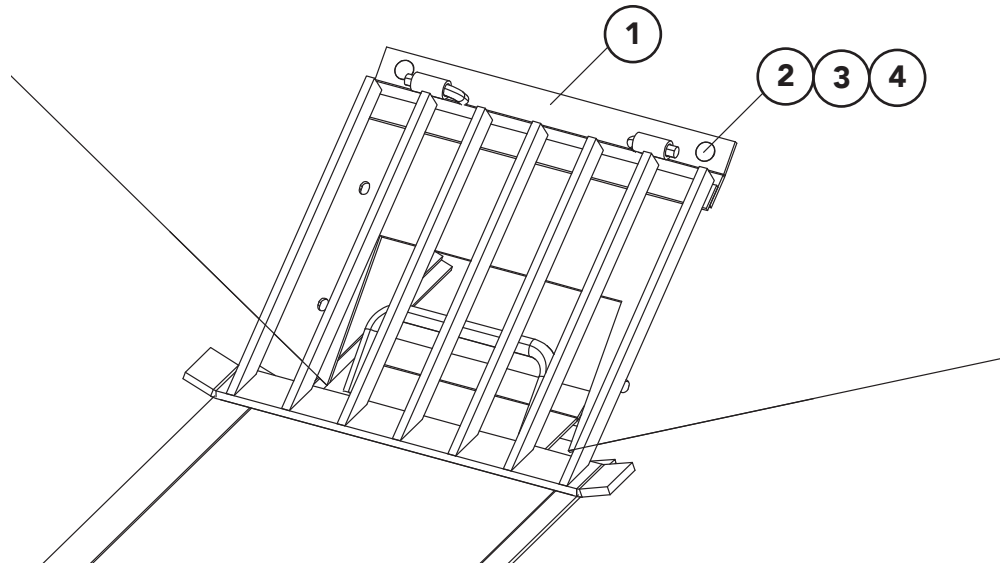

<u>ITEM</u>	<u>PART NO.</u>	<u>DESCRIPTION</u>	<u>QTY</u>	
	CS	304 SS		
	96407	317510	DIVERTER – KIT CLUMP SCREEN	
1	96401	317541	DIVERTER – WELDMENT CLUMP SCREEN	1
2	20265	40750	BOLT – CARRIAGE 1/4-20 NC x 1-1/4	2
3	20710	36418	WASHER – LOCK 1/4	2
4	20642	36412	NUT – HEX 1/4-20 NC	2

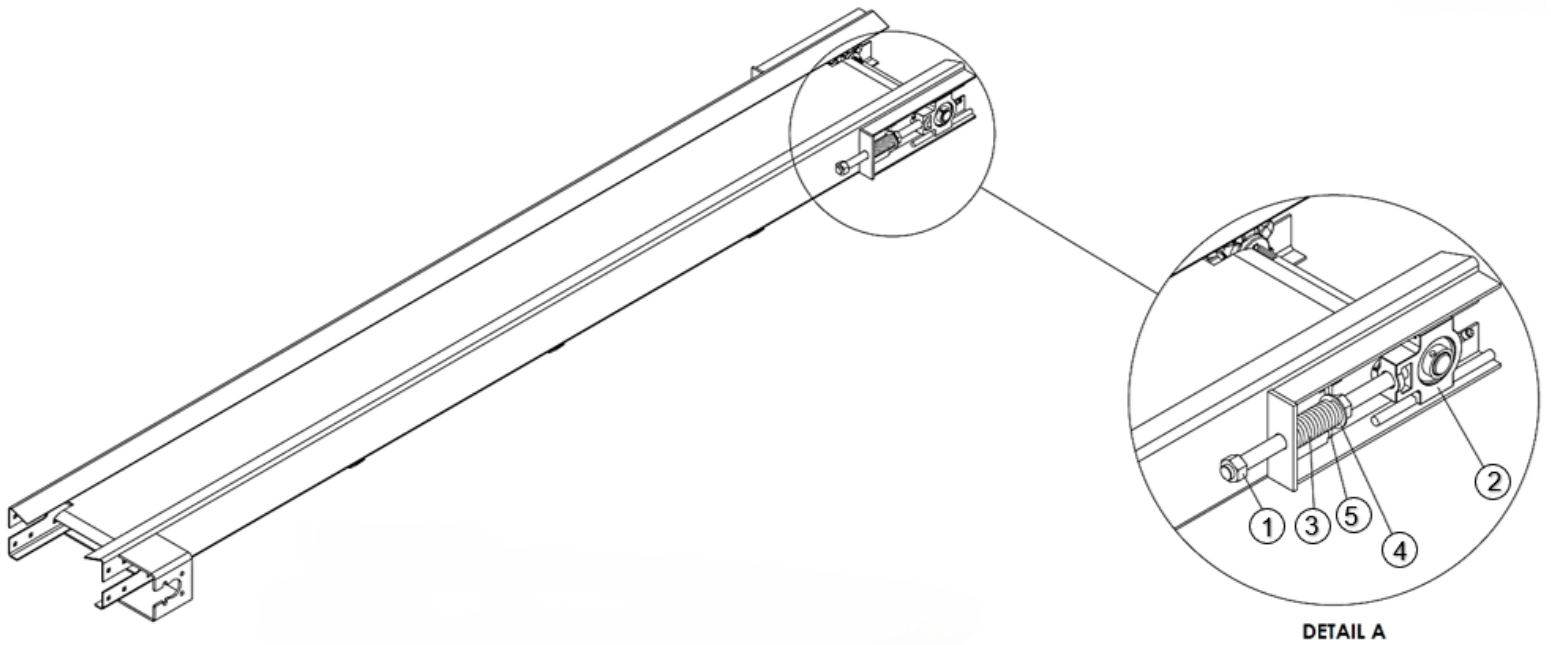

ITEM	PART NO.		QTY	
	CS	304 SS		
	85991	85991	SHAFT - IDLER ASSY, INCLUDES 1-6	
1	84479	84479	SHAFT - IDLER	1
2	26653	26653	SPROCKET	2
3	20735	20735	SCREW- SET	4
4	79856	79856	KEY - SQUARE	2
5	56417	56417	BEARING - TAKE-UP	2
6	34734	34734	ADAPTER - ELBOW	2
7	323616	323616	BOLT - WLDMT TAKE UP 304	2
8	323619	323619	SPRING - COMPRESSION IDLER	2
9	56408	56408	WASHER - FLAT .75 304	2
10	323618	323618	NUT - WLDMT .75-10NC SS	2
11	*6000	*6000	COUPLING	4
12	*6069	*6069	ZERK - GREASE	4
13	*85894	*85894	HOSE - ASSEMBLY 1/4 " X 20	2
14	*85895	*85895	HOSE - ASSEMBLY 1/4 " X 26	2

* - Not Shown

Conveyor Drive

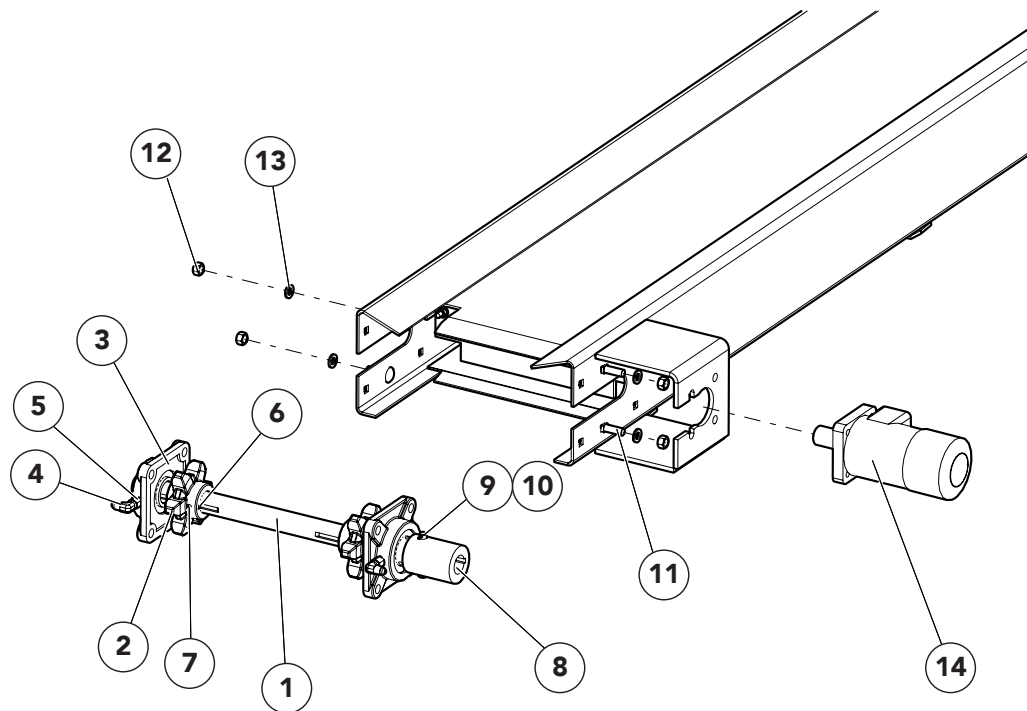

ITEM	PART NO.		DESCRIPTION	QTY
	CS	304 SS		
	85992	85992	SHAFT - DRIVE ASSY, INCLUDES 1 - 10	
1	26651	26651	SHAFT - DRIVE	1
2	26653	26653	SPROCKET	2
3	942	942	BEARING	2
4	34734	34734	ADAPTER - ELBOW	2
5	34798	34798	ADAPTER - ZERK	2
6	79856	79856	KEY - SQUARE	2
7	20735	20735	SET SCREW - 1/4-20 NC x 1/4	4
8	79709	79709	COUPLING - DRIVE	1
9	6123	6123	PIN - CLEVIS	1
10	20811	20811	PIN - COTTER	1
11	20319	36409	BOLT - CARRIAGE 3/8-16 NC x 1-1/4	8
12	20644	36414	NUT - HEX 3/8-16 NC	8
13	20712	36420	WASHER - LOCK 3/8	8
14	315850	315850	MOTOR - HYDRAULIC	1
15	*20067	36398	CAP SCREW - 3/8-16 NC x 1	4
* - Not Shown				



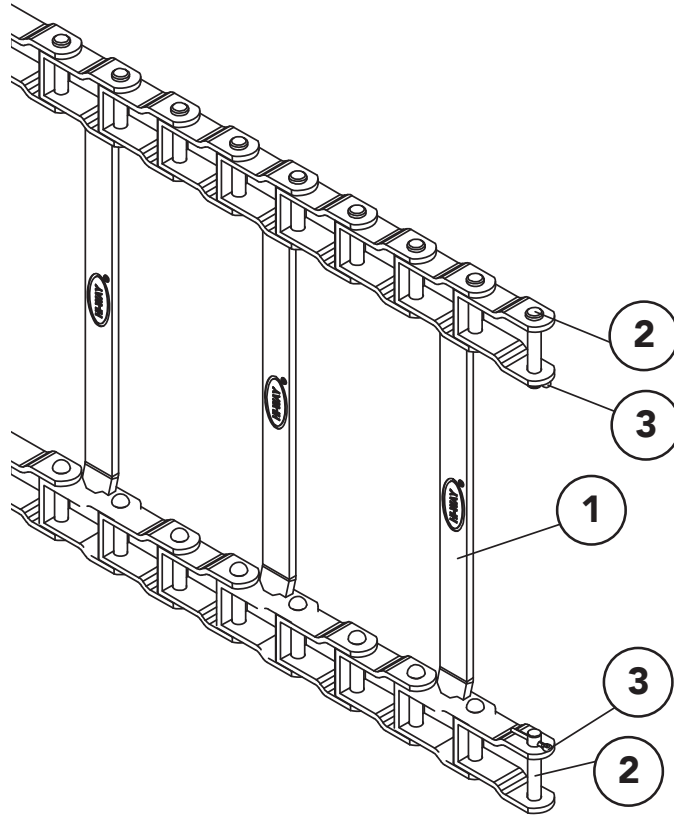

ITEM	PART NO.	DESCRIPTION	QTY
	85822	CHAIN - ASSEMBLY #1 9' 12.5"	
1	85821	CHAIN - WELDMENT #1 9' 12.5"	1
2	26702	PIN - CLEVIS	2
3	20811	PIN - COTTER	2

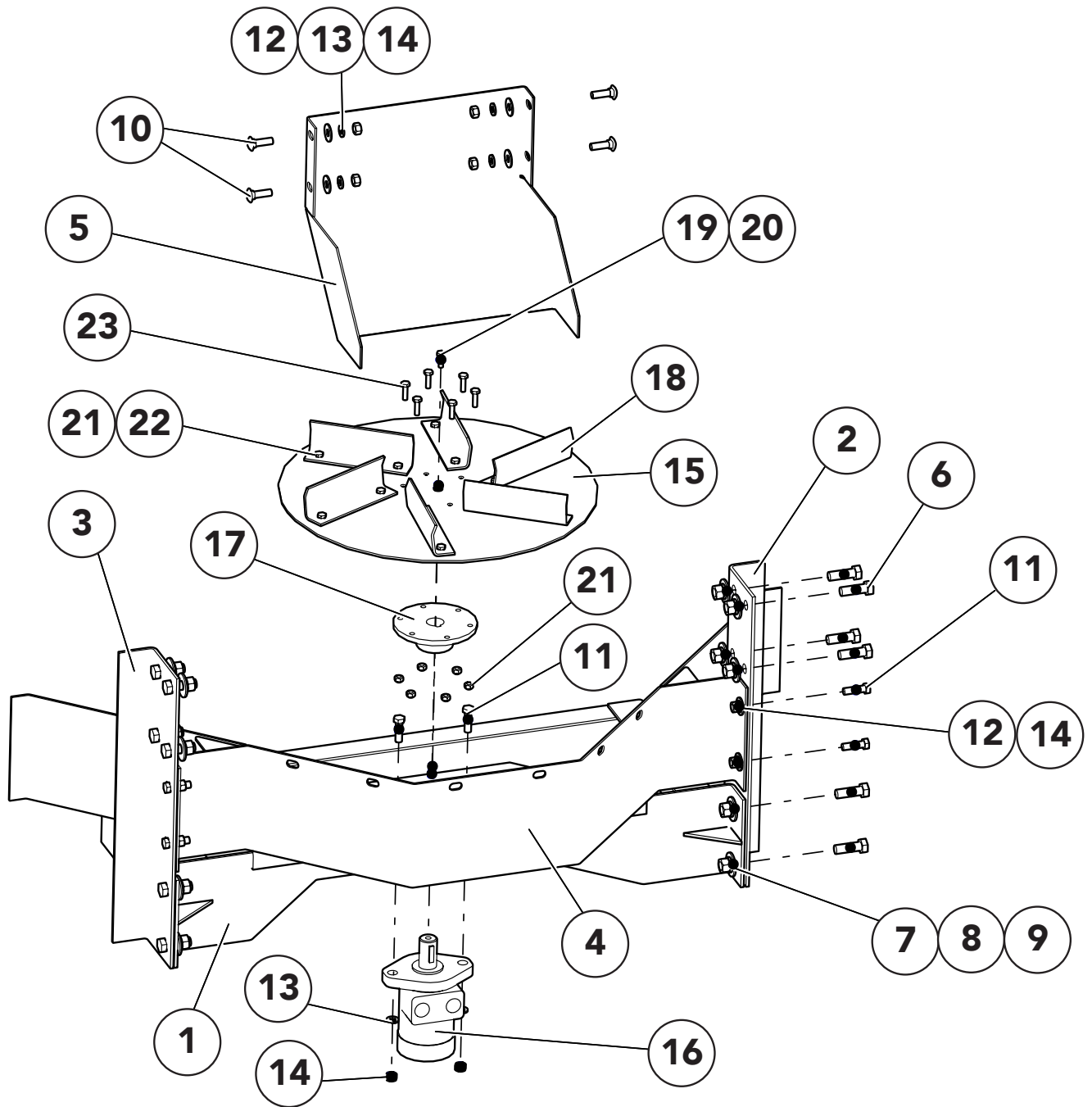

Spinner Continued

ITEM	PART NO.		DESCRIPTION	QTY
	<u>CS</u>	<u>304 SS</u>		
1	85139	317598	FRAME – SPINNER WELDMENT	1
2	85868	317526	SUPPORT – SPINNER LH	1
3	85869	317527	SUPPORT – SPINNER RH	1
4	85887	317524	SHIELD – SPINNER WELDMENT	1
5	85874-X1	85874-X1	CHUTE WELDMENT	1
6	20129	36539	CAP SCREW – 1/2 X 1-1/2	12
7	20695	36426	WASHER – FLAT 1/2	12
8	20714	36422	WASHER – LOCK 1/2	12
9	20646	36416	NUT – HEX 1/2	12
10	20319	36409	BOLT – CARRIAGE 3/8 X 1-1/4	4
11	20068	36399	CAP SCREW – 3/8 X 1-1/4	6
12	20693	36425	WASHER – FLAT 3/8	8
13	20712	36420	WASHER – LOCK 3/8	10
14	20644	36414	NUT – HEX 3/8	10
15	88519	317709	DISC – SPINNER	1
16	37339	37339	MOTOR – HYDRAULIC	1
	39137	39137	KIT - SEAL	1
17	74122	74122	HUB – DISC SPINNER	1
18	2240	317597	FIN – BLADE	6
19	36393	36393	CAP SCREW – 1/4 X 3/4 SS	1
20	36418	36418	WASHER – LOCK 1/4	1
21	20676	36412	NUT – LOCK 1/4	18
22	20003	36412	CAP SCREW – 1/4 X 3/4	12
23	20004	36393	CAP SCREW – 1/4 X 7/8	6
24	*89050	*317525	GUARD - SPINNER	1

* - Not Shown



Pre-Wet Calcium Reservoir

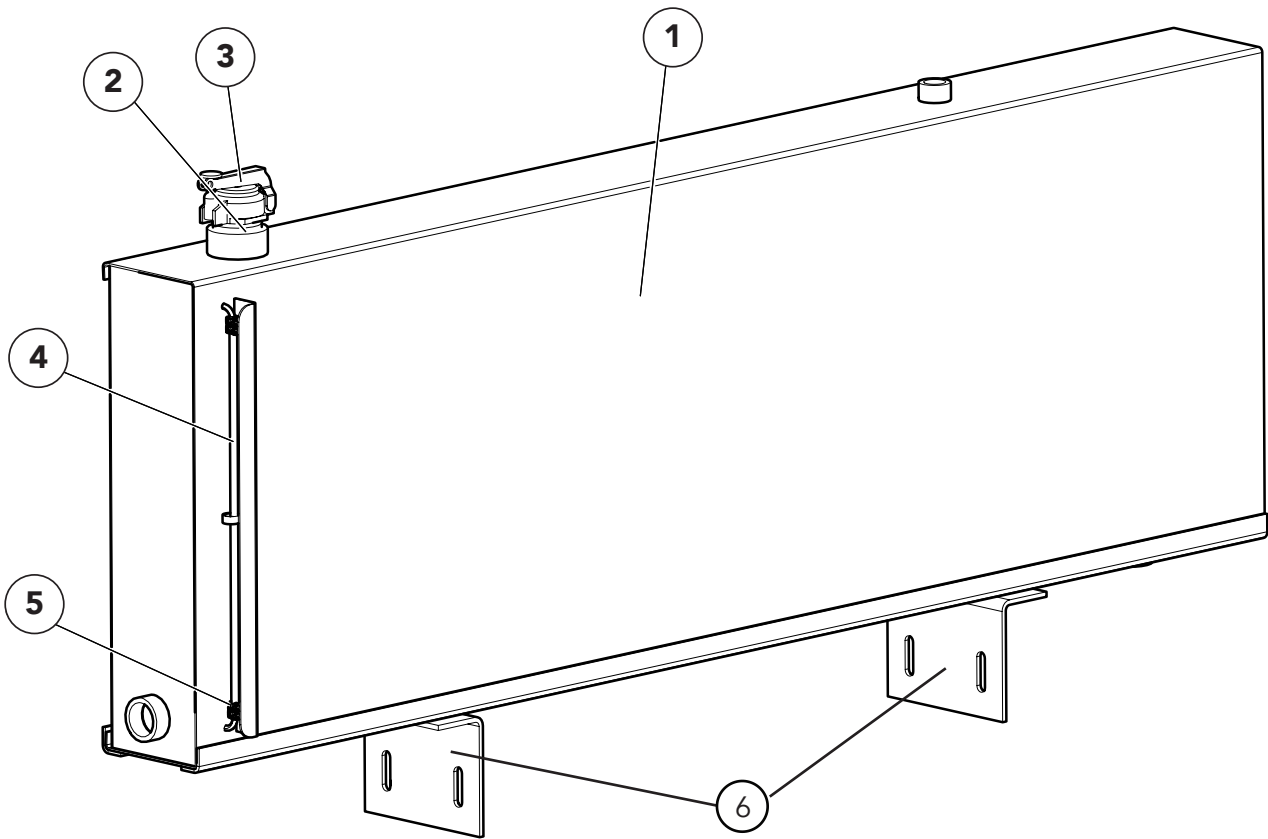

ITEM	PART NO.	DESCRIPTION	QTY
1	303825	RESERVOIR – WELDMENT 40GAL	1
2	312943	NIPPLE - CLOSE 2 NPT BRASS	1
3	21850-X1	CAP - FILL	1
4	50967-20	TUBE – CLEAR 1/4 x 20	1
5	312945	CLAMP - HOSE	4
6	88598	AGNLE – MOUNTING TANK 304	2
7	* 304381	PRE-WET – SYSTEM PLUMBING & POWER	1
8	*20129	CAP SCREW - 1/2-13 NC x 1-1/2	4
9	*20695	WASHER – FLAT 1/2	8
10	*20680	NUT – LOCK 1/2-13 NC	4
* - Not Shown			



Pre-Wet Pump & Fittings

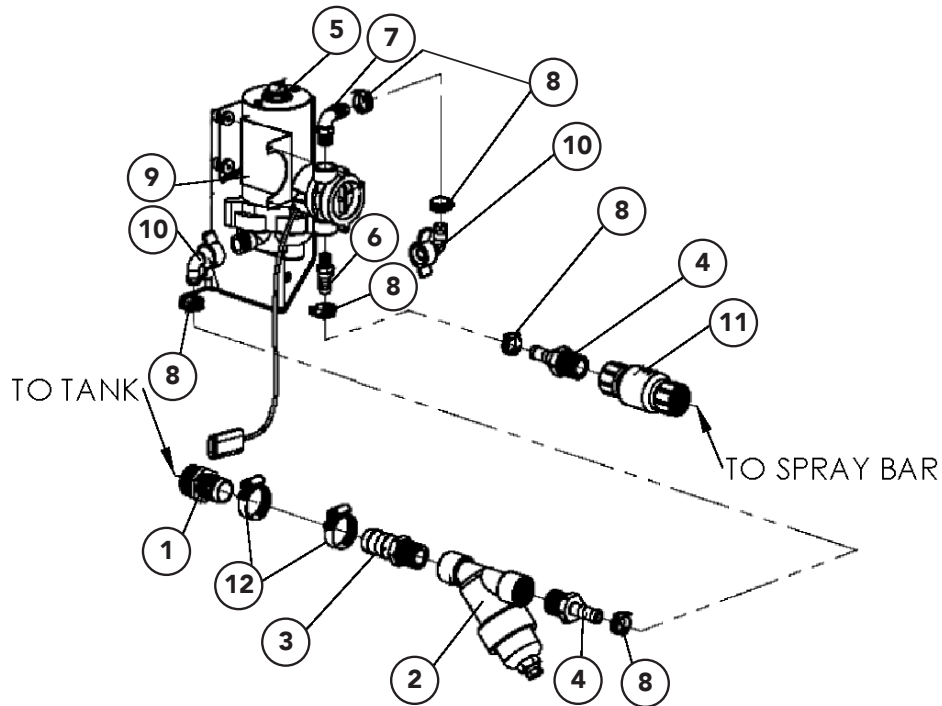

ITEM	PART NO.	DESCRIPTION	QTY
	304381	PRE-WET – ASSY	
1	304853	BARB – HOSE 1 X 1 MNPT	2
2	96514	FILTER – STRAIN 3/4" NPT	1
3	304854	BARB – HOSE 1 X 3/4 MNPT	1
4	96510	BARB – HOSE 1/2 X 3/4 NPT	2
5	304855	PUMP – 3.3 GPM 12V DC	1
6	96534	BARB – HOSE 1/2 X 1/4 MNPT POLY	1
7	304856	BARB – HOSE ELBOW 1/2 X 1/4 MNPT POLY	1
8	96556	CLAMP – 1/2 SS	8
9	304857	MOUNT – FLOW METER	1
10	96539	BARB – HOSE SWIVEL	1
11	304859	VALVE – CHECK 3/4 NPT	1
12	304869	CLAMP – 1" HOSE SS	2

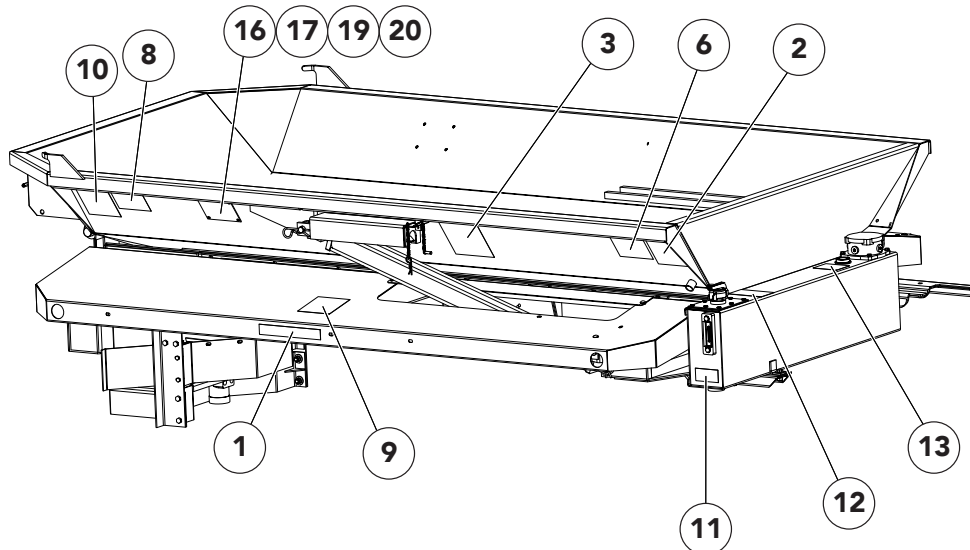
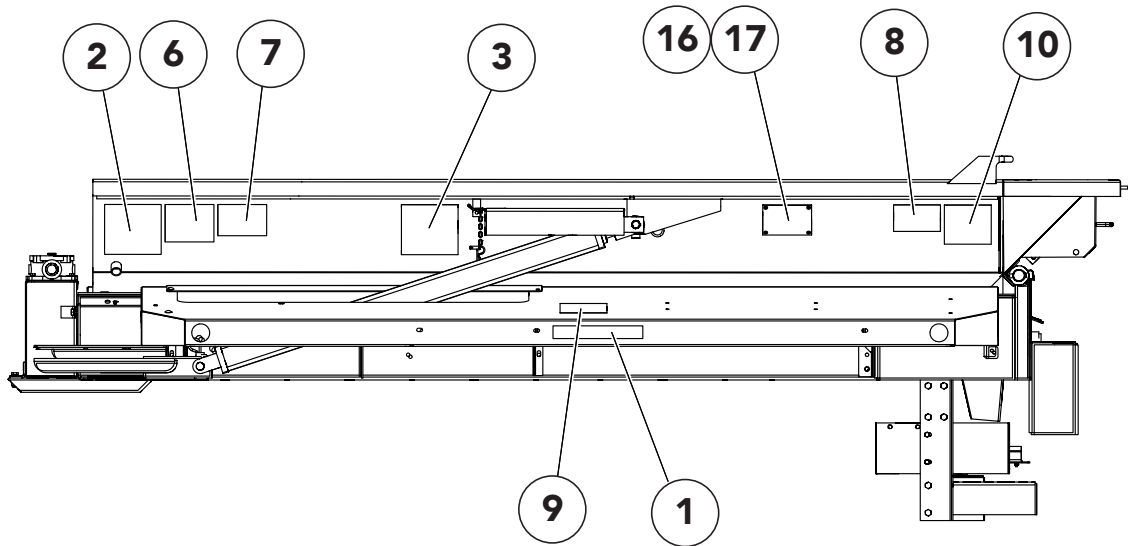
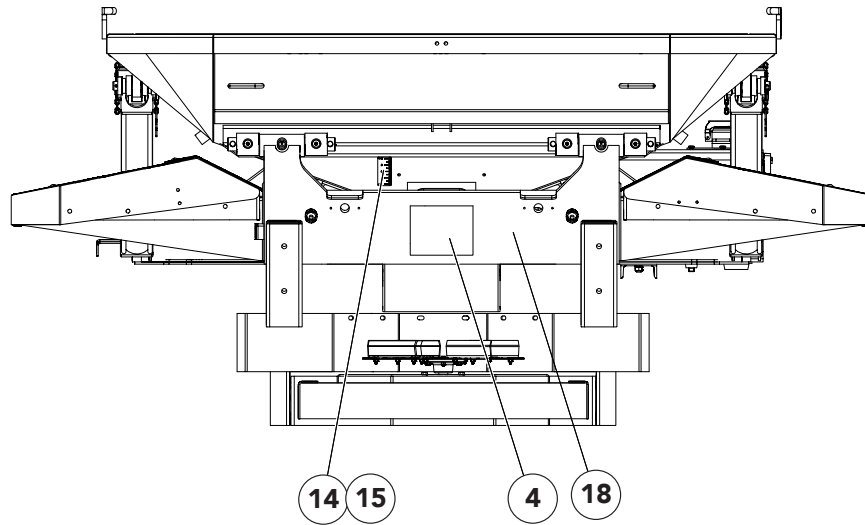

<u>ITEM</u>	<u>PART NO.</u>	<u>DESCRIPTION</u>	<u>QTY</u>
1	39200	DECAL – KEEP OFF FENDERS	2
2	150034	DECAL – READ MANUAL	1
3	39138	DECAL – HIGH PRESSURE HAZARD	2
4	83649	DECAL – FLYING MATERIAL	1
5	21476	DECAL – CHAIN LUBRICATION	1
6	364	DECAL – STAY OUT OF BOX	2
7	321	DECAL – HAZARDOUS MATERIALS	1
8	55631	DECAL – MOVING PART	2
9	170001	DECAL – CRUSHING HAZARD	2
10	55241	DECAL – PINCH POINT	2
11	8664	DECAL – KEEP VALVE OPEN	1
12	8665	DECAL – HYDRAULIC OIL ONLY	1
13	39378	DECAL – CHANGE FILTER	1
14	96398	SCALE – FEEDGATE SS	1
15	82000	RIVET – POP SS	4
16	85982	DECAL – LUBE CHART	2
17	44453	SCREW - ROUND HEAD #10-24NC	8
18	315865	Decal - WARNING: HAZARDOUS MATERIALS	1
19	171052	WASHER – FLAT #10 SS	8
20	56355	NUT – LOCK #10-24 NC SS	8

This page is intentionally left blank.